

TEMPCO®

PPS Series Data Recorder



Safety

This recorder is compliant with the requirements of EN61010-1, UL 61010C-1 & CSA C22.2 No. 24-93. If the equipment is used in a manner not specified by the manufacturer, the protection provided by the equipment may be impaired. Tempco Electric Heater Corporation is not liable for any damages incurred to equipment/personal during installation or use of equipment as explained in this document. User must acquire sufficient knowledge & skills prior to using equipment in the application and follow all the local standards & regulations to meet safety requirements.

Warning Symbol

This document contains notices that you should observe to ensure your own personal safety, as well as to protect the product and connected equipment. These notices are highlighted in the manual by a warning triangle and are marked as follows.

 The danger symbol indicates that death or severe personal injury may result if proper precautions are not taken. Do not proceed beyond a warning symbol until the indicated conditions are fully understood and met.

Before connecting the power cord, ensure that the power supply voltage matches the voltage rating for the instrument.

 Make sure to connect the protective grounding to prevent electric shock before turning ON the power. Never cut off the internal or external protective grounding wire or disconnect the wiring of the protective grounding terminal. Doing so will pose a potential shock hazard. Do not operate the instrument when the protective grounding or the fuse might be defective. Also, make sure to check them before operation.

- ❖ Do not operate the instrument in the presence of flammable liquids or vapours. Operation of any electrical instrument in such an environment constitutes a safety hazard.
- ❖ Some areas inside the instrument have high voltages. Do not remove the cover if the power supply is connected. The cover should be removed by our qualified personnel only.
- ❖ Using the instrument in a manner not specified in this manual can damage the instrument's protection
- ❖ Keep signal and supply voltage wiring separated from one another. If this is impractical, use shielded cables for signal wiring. Double insulation should be used for signal wiring when the recorder is used with hazardous voltage.
- ❖ Do not use the recorder where there is high vibration or a high magnetic field. This could cause damage or error of measurement.
- ❖ All maintenance or repairs should be carried out with power disconnected to avoid personal injury or damage to the unit.
- ❖ In areas with conductive pollution, adequate ventilation, filtering and sealing must be installed.
- ❖ When cleaning the recorder, handle carefully and use soft dry cloth. Avoid the use of abrasives, or any sharp or hard objects which would damage the display.
- ❖ Do not operate the recorder if any part has been removed or disassembled. Consult your nearest dealer at once.
- ❖ **Static Electricity:** Appropriate precautions must be taken when handling the recorder. The circuit board components are susceptible to damage caused by electrostatic discharge. Take static electricity precautions while handling and inserting USB memory into the recorder.

Preface

Original equipment manufacturer reserves the right to change information available in this document without notice. Manufacturer is not liable for any damages incurred to equipment/personal during installation or use of equipment as explained in this document. User must acquire sufficient knowledge & skills prior to using equipment in the application and follow all the local standards & regulations to meet safety requirements.

Copyright

The documentation and the software included with this product are copyrighted 2019 by Tempco electric Heater Corporation. All rights are reserved. Tempco Electric Heater Corporation. reserves the right to make improvements in the products described in this manual at any time without notice.

No part of this manual may be reproduced/copied/translated or transmitted in any form or by any means without the prior written permission of Tempco Electric Heater Corporation. The information we supply is believed to be accurate and reliable as of this printing. However, we assume no responsibility for its use.

Contact Information

Tempco Electric Heater Corporation

607 North Central Avenue, Wood Dale, Illinois 60191 USA

Tel: (630) 350-2252 Fax: (630) 350-0232 E-mail: info@tempco.com

<http://www.tempco.com>

Table of Contents

1.	INTRODUCTION	12
1.1	INTRODUCTION	12
1.2	FEATURES	12
1.2.1	Hardware	12
1.2.2	Firmware	12
1.2.3	PC Software	13
1.2.4	Firmware and Software Features	13
1.3	COMPARISON OF PPS SERIES RECORDERS	16
1.4	EXPANDABLE INPUT AND OUTPUT CARDS	16
1.4.1	Analog Input cards (part number PPS90001 & PPS90002)	16
1.4.2	Relay Output card (PPS90003)	17
1.4.3	Digital Input card (PPS90004)	17
1.4.4	Combination Relay Output and Digital Input Card (PPS90005)	17
1.4.5	Analog Output cards (PPS90006)	17
1.4.6	Process Control card (PPSPCM)	18
1.5	COMMUNICATION	18
1.6	EXTERNAL STORAGE MEDIA	18
1.7	SMART MECHANISM	19
1.8	ORDERING CODE	20
1.8.1	PPS-1000 Ordering code	20
1.8.2	PPS-2000 Ordering code	21
1.8.3	PPS-3000 Ordering code	23
1.8.4	PPSPCM Ordering code	24
1.8.5	Accessories	24
1.9	SPECIFICATIONS	25
1.9.1	General Specifications	25
1.9.2	Analog Input Specifications (PPS90002 & PPS90001)	26
1.9.3	Digital Input Specifications (PPS90004 & PPS90005)	29
1.9.4	Relay Output Specifications (PPS90003 & PPS90005)	29
1.9.5	Analog Output Specifications (PPS90006)	29
1.9.6	PID Process Control card Specifications (PPSPCM)	29
1.9.6.1	Input1	29
1.9.6.2	Input 2	30
1.9.6.3	Input3 (Event Input)	31
1.9.6.4	Output1/Output2	31
1.9.6.5	Alarm 1/ Alarm 2	32
1.9.6.6	Control Mode	32
1.9.6.7	Profiler	32
1.9.6.8	Digital Filter	32
1.9.7	COMM Module (IF232 and IF485) Specifications	32
1.9.8	Standard Ethernet Communication	33
1.9.9	Real-time Clock	33
1.9.9.1	Real time Clock accuracy vs Temperature inside of the housing	33
1.9.10	Environmental & Physical Specifications	33
1.9.11	Approval Standards	33
2.	INSTALLATION AND WIRING	34
2.1	UNPACKING	34
2.2	DIMENSIONS	35
2.2.1	Panel mounting style	35
2.2.1.1	PPS-1000	35
2.2.1.2	PPS-2000	36
2.2.1.3	PPS-3000	38
2.2.2	Portable styles	39
2.2.2.1	Bottom Side View of PPS-2000 & PPS-1000	40

2.2.2.2	Front Side View of PPS-2000 & PPS-1000	40
2.2.2.3	Bottom Side View of PPS-3000	41
2.2.2.4	Front Side View of PPS-3000.....	41
2.2.2.5	Bottom Stand Clips.....	42
2.2.2.6	Top Holding Handle.....	42
2.3	INPUT AND OUTPUT CONFIGURATION	42
2.3.1	<i>Analog Input Card</i>	42
2.3.2	<i>Relay Output card</i>	43
2.3.3	<i>Digital Input card</i>	44
2.3.4	<i>Combination Digital Input and Output card</i>	44
2.3.5	<i>Analog output cards</i>	45
2.3.6	<i>PID Process Control Module</i>	45
2.4	WIRING	46
2.4.1	<i>Wiring Precautions</i>	46
2.4.2	<i>Analog Input Wiring</i>	47
2.4.2.1	PPS90001 6 channel analog input wiring.....	47
2.4.3	<i>Relay Output Wiring</i>	48
2.4.3.1	PPS90003 6 channel relay output wiring	48
2.4.4	<i>Digital Input Wiring</i>	48
2.4.4.1	PPS90004 6 channel digital input wiring.....	48
2.4.5	<i>Combination Relay Output and Digital Input Wiring</i>	49
2.4.5.1	PPS90005 3 Output and 3 channel Digital Input Wiring.....	49
2.4.6	<i>Analog Output Wiring</i>	49
2.4.6.1	PPS90006 6 channel analog output wiring	49
2.4.7	<i>PID Process Control Card Wiring</i>	50
2.4.7.1	PPSPCM.....	50
2.4.8	<i>RS-232, RS-422, and RS-485 wiring</i>	50
2.4.8.1	RS232 Wiring.....	50
2.4.8.2	RS422 Wiring.....	51
2.4.8.3	RS485 Wiring.....	51
2.5	EXTERNAL MEMORY CARD	51
3.	BASIC FUNCTIONS OF RECORDERS.....	53
3.1	CONFIGURATION	53
3.2	FIRMWARE.....	53
3.2.1	<i>Standard Firmware</i>	53
3.2.2	<i>Plus 1 Firmware</i>	53
3.2.3	<i>Plus 2 Firmware</i>	53
3.2.4	<i>Plus 3 Firmware</i>	53
3.3	PULSE INPUT THROUGH DIGITAL INPUT	54
3.4	PID CONTROL WITH RAMP & SOAK PROFILE FUNCTION	54
3.5	ON FIELD CALIBRATION	54
3.6	COMMUNICATION WITH THIRD PARTY INTERFACES	54
3.7	WEB SERVER	54
3.8	EMAIL	54
3.9	HANDWRITING MESSAGES ON HISTORICAL TREND SCREENS	55
3.10	CUSTOM DISPLAY SCREEN	55
3.11	LOG SPEED FLEXIBILITY	55
3.12	SYSTEM CLOCK SYNCHRONIZATION VIA INTERNET	56
3.13	INCREASED SECURITY	56
3.14	AUTO OUTPUT TO PRINTER	56
3.15	EXTERNAL CHANNELS	56
3.16	BATCH	56
3.17	FDA 21 CFR PART 11.....	56
3.18	CIRCULAR CHART.....	56
3.19	MULTILINGUAL LANGUAGES	57
3.20	USB BARCODE READER, KEYBOARD AND MOUSE CONNECTIVITY.....	57
4.	GETTING STARTED.....	58

4.1	SCREEN NAVIGATION	58
4.1.1	Title Bar.....	58
4.1.1.1	Menu key	58
5.	CONFIGURATION.....	74
5.1	CHANNEL.....	76
5.1.1	Analog Input	76
5.1.1.2	Desc.....	77
5.1.1.3	Type.....	77
5.1.1.4	Filter	77
5.1.1.5	Log.....	79
5.1.1.6	Sensor	80
5.1.1.7	Offset	81
5.1.1.8	Gain	81
5.1.1.9	Modbus	81
5.1.1.10	Events.....	81
5.1.2	Digital Input	83
5.1.2.2	Desc.....	84
5.1.2.3	Type.....	84
5.1.2.4	Events.....	85
5.1.3	Math Channel	87
5.1.3.2	Desc.....	88
5.1.3.3	Type.....	88
5.1.3.4	Log.....	89
5.1.3.5	Expression	90
5.1.3.6	Scale	92
5.1.3.7	Modbus	95
5.1.3.8	Events.....	95
5.1.3.9	Examples for Math Channel Application.....	97
5.1.4	Analog Output	103
5.1.4.1	Desc.....	105
5.1.4.2	Type.....	105
5.1.4.3	Output.....	105
5.1.4.4	Expression	105
5.1.4.5	Modbus	106
5.1.5	Digital Output	106
5.1.5.1	Desc.....	107
5.1.5.2	Reverse.....	107
5.1.6	External.....	107
5.1.6.1	Name.....	108
5.1.6.2	Desc.....	108
5.1.6.3	Type.....	108
5.1.6.4	Log.....	108
5.1.6.5	Modbus Register Value Conversion	109
5.1.6.6	Modbus	110
5.1.6.7	Events.....	110
5.2	CONTROLLER	111
5.2.1	Name	112
5.2.2	Parameter.....	112
5.2.2.1	Parameter Configuration	113
5.2.3	Channel.....	129
5.2.3.1	Name.....	130
5.2.3.2	Desc.....	130
5.2.3.3	Type.....	131
5.2.3.4	Source	131
5.2.3.5	Log.....	131
5.2.3.6	Modbus	132
5.2.3.7	Events.....	132
5.2.4	Configuration of Process Control Card.....	134
5.2.4.1	Heat Only ON-OFF Control	134
5.2.4.2	Cool Only ON-OFF Control	135
5.2.4.3	Heat Cool Control.....	135
5.2.4.4	Heater Break Alarm.....	136

5.2.4.5	Loop Break Alarm.....	136
5.2.4.6	Sensor Break Alarm.....	137
5.2.4.7	Failure Transfer.....	137
5.2.4.8	Bumpless Transfer.....	138
5.2.4.9	PV1 Shift.....	139
5.2.4.10	SP1 Range.....	139
5.2.4.11	Dwell Timer.....	140
5.2.4.12	Process Alarms.....	140
5.2.4.13	Event Input.....	144
5.2.4.14	Second Set Point.....	145
5.2.4.15	Second PID Set.....	145
5.2.4.16	Ramp & Dwell.....	146
5.2.4.17	Remote Set Point.....	147
5.2.4.18	Differential Control.....	148
5.2.4.19	Output Power Limit.....	148
5.2.4.20	Digital Filter.....	149
5.2.4.21	Auto-Tuning and Manual Tuning.....	149
5.2.5	<i>Profile</i>	151
5.2.5.1	Ramp & Dwell.....	152
5.2.5.2	Name.....	153
5.2.5.3	Segments.....	153
5.2.5.4	Jobs.....	156
5.2.5.5	Start/Stop Profile (Ramp & Dwell).....	157
5.2.5.6	Oven Control with Zone Temperature Recording Application.....	158
5.3	JOBS	159
5.3.1	<i>No Action</i>	159
5.3.2	<i>Send Email</i>	159
5.3.3	<i>Pause</i>	159
5.3.4	<i>Start</i>	159
5.3.5	<i>Sound Buzzer</i>	159
5.3.6	<i>Dump Data</i>	159
5.3.7	<i>DO Latch On</i>	159
5.3.8	<i>DO Latch Off</i>	159
5.3.9	<i>DO Process</i>	159
5.3.10	<i>Enable Timer</i>	160
5.3.11	<i>Disable Timer</i>	160
5.3.12	<i>Preset Totalizer</i>	160
5.3.13	<i>Reset Totalizer</i>	160
5.3.14	<i>Enable Totalizer</i>	160
5.3.15	<i>Disable Totalizer</i>	160
5.3.16	<i>Preset Counter</i>	160
5.3.17	<i>Reset Counter</i>	160
5.3.18	<i>Inc Counter</i>	160
5.3.19	<i>Dec Counter</i>	160
5.3.20	<i>Log Report</i>	160
5.3.21	<i>Reset MinMaxAve</i>	160
5.3.22	<i>Print Historical data</i>	160
5.3.23	<i>Print Event List</i>	160
5.3.24	<i>Print Report List</i>	160
5.3.25	<i>Print Snapshot</i>	161
5.3.26	<i>Output Historical Data</i>	161
5.3.27	<i>Copy Value and Paste Value</i>	161
5.3.28	<i>Select Controller</i>	161
5.3.29	<i>Run Profile</i>	161
5.4	DISPLAY	161
5.4.1	<i>Name</i>	162
5.4.2	<i>Mode</i>	162
5.4.3	<i>Speed</i>	162
5.4.4	<i>Direction</i>	163
5.4.5	<i>Background</i>	163

5.4.6	<i>Print Enable</i>	163
5.4.7	<i>Trend Graph Scale</i>	163
5.4.8	<i>Pen</i>	164
5.4.8.1	Channel	164
5.4.8.2	Color.....	164
5.4.8.3	Width	164
5.4.8.4	Range Low.....	164
5.4.8.5	Range High	164
5.4.8.6	Reference points	164
5.4.8.7	Trend Graph scale position	165
5.4.8.8	Status Bar.....	165
5.5	BATCH	167
5.5.1	<i>Name</i>	167
5.5.1.1	Lot Number	167
5.5.2	<i>Desc</i>	167
5.5.3	<i>Example for Batch Application</i>	168
5.5.4	<i>How to view batch data in Recorder</i>	168
5.5.5	<i>How to Dump Batch data to external USB memory</i>	169
5.6	START / STOP	170
5.6.1	<i>Start</i>	170
5.6.2	<i>Stop</i>	170
5.7	TIMER	171
5.7.1	<i>Type</i>	171
5.7.1.1	Countdown.....	172
5.7.1.2	Repeat Countdown	172
5.7.1.3	Daily	172
5.7.1.4	Weekly	172
5.7.1.5	Monthly.....	172
5.7.2	<i>Action</i>	172
5.7.3	<i>Job1, Job2</i>	172
5.7.4	<i>Timer Example-1</i>	172
5.7.5	<i>Timer Example-2</i>	172
5.7.5.1	Timer Example-3	173
5.8	CLOCK	173
5.8.1	<i>Date Style</i>	173
5.8.2	<i>Time Zone</i>	174
5.8.3	<i>Synchronize via Internet</i>	174
5.8.4	<i>Date / Time</i>	174
5.8.5	<i>Summer time</i>	174
5.9	COMMUNICATION	174
5.9.1	<i>Ethernet</i>	174
5.9.2	<i>Serial</i>	175
5.9.3	<i>Modbus Server / Slave</i>	175
5.9.4	<i>Modbus Client/Master</i>	175
5.9.4.1	Connections	175
5.9.4.2	Commands	176
5.9.4.3	Sample Rate	177
5.9.5	<i>Email</i>	177
5.9.6	<i>Example for IO Modules as External Channels</i>	179
5.9.7	<i>Example for Controller as External Channels</i>	182
5.9.8	<i>Example for SIO Module as External Channel via PC-E</i>	185
5.9.9	<i>Example for Recorder as Modbus Slave</i>	189
5.10	INSTRUMENT	190
5.10.1	<i>Name</i>	191
5.10.2	<i>Language</i>	191
5.10.3	<i>Security</i>	191
5.10.3.1	Logout	191
5.10.3.2	Password validity	191
5.10.3.3	Security Level of Functions	191
5.10.4	<i>Batch Control</i>	192

5.10.5	Volume	192
5.10.6	Tool Bar	192
5.10.7	Scan Page	192
5.10.8	LCD	192
5.10.9	Storage	192
5.10.10	Data Transfer	192
5.10.10.1	Show Message at the End	192
5.10.11	Custom Page	192
5.10.11.1	Power on	193
5.10.12	Setup Start-up Image	193
5.10.12.1	Procedure to Setup a Start-up Image	193
5.11	SECURITY	193
5.11.1	Normal	193
5.11.2	CFR-21	194
5.11.2.1	User Account	194
5.12	DEMO	195
5.13	AUTO-OUTPUT	195
5.13.1	Setup Printer	195
5.13.2	Print Header	196
5.13.3	Title	196
5.13.4	Historical Data	196
5.13.5	Report Data	197
5.13.6	Output Files	197
5.13.7	USB Printer Configuration	197
5.13.8	Network Printer Configuration	197
5.13.9	Sample Configuration of Printer	197
5.14	SYSTEM INFORMATION	201
5.14.1	Firmware Upgrade	201
5.14.2	Touch Screen Calibration	202
5.14.2.1	Batch Example-1	203
5.15	CALIBRATE	206
5.15.1	Calibrate an AI with 0-5V	208
5.15.2	Calibrate an AI with K type Thermocouple	210
5.15.3	Calibrate an AI with Pt100 RTD	212
5.15.4	Calibrate an AO with 4 to 20 mA	215
5.15.5	Calibrate an AO with 0 to 10 V	218
5.16	PROCEDURE TO UPGRADE AND RESTORE FACTORY DEFAULT SETTINGS	222
6.	PC BASED SOFTWARE	224
6.1	FREE BASIC SOFTWARE	224
6.1.1	Historical Viewer Software Installation	224
6.1.1.1	System Requirements	224
6.1.1.2	Software Installation	224
6.1.1.3	Uninstallation of Software	227
6.1.2	Start and Exit	227
6.1.3	Historical Viewer	227
6.1.3.1	Historical Viewer-Tool Bar	228
6.1.3.2	Historical Viewer-Menu Bar	229
6.1.3.3	Configuration Viewer-Tool Bar	234
6.1.3.4	Configuration Viewer-Menu Bar	235
6.1.3.5	Create a New Project	237
6.1.3.6	Open an Existing Project	239
6.1.3.7	Automatic Import of Data	241
6.1.3.8	Automatic Import and Export of Data	241
6.1.3.9	Multiple Projects Automatic Import and Export of Data	242
6.2	EXTENSIVE SOFTWARE	244
6.2.1	Data Acquisition Studio Software Installation	244
6.2.1.1	System Requirements	244
6.2.1.2	Software Installation	244
6.2.1.3	Uninstallation of Software	246

6.2.2	<i>Start and Exit</i>	246
6.2.3	<i>Real Time Viewer</i>	246
6.2.3.1	Real Time Viewer – Tool Bar	246
6.2.3.2	Real Time Viewer – Menu Bar	247
6.2.3.3	Real-time Configuration Viewer-Tool Bar	250
6.2.3.4	Create a New Project	266
6.2.3.5	Open an Existing Project	271
6.2.3.6	Add a Device to the Existing Device	272
6.2.3.7	PR-DAQ RS485 Communication	273
6.2.3.8	PR-DAQ Ethernet Communication	277
6.2.4	<i>Dynamic Data Exchange (DDE)</i>	281
6.2.4.1	Procedure to find the tag number for the tag name to use in DDE applications	283
6.2.4.2	DDE with 3 rd party applications	283
6.2.5	<i>Configuration of Recorder</i>	284
6.2.5.1	On the Recorder	284
6.2.5.2	Software via Ethernet port.....	284
6.2.5.3	Removable Media	286
6.3	CUSTOM SCREEN EDITING SOFTWARE - PANEL STUDIO	290
6.3.1	<i>Panel Studio Software Installation</i>	291
6.3.1.1	System Requirements	291
6.3.1.2	Software Installation	291
6.3.1.3	Uninstallation of Software	293
6.3.2	<i>Start and Exit</i>	293
6.3.3	<i>Project status</i>	293
6.3.4	<i>Create new project</i>	294
6.3.5	<i>Menu bar</i>	295
6.3.5.1	File.....	295
6.3.5.2	Edit	298
6.3.5.3	Format.....	298
6.3.5.4	View	301
6.3.5.5	Objects	303
6.3.5.6	Project.....	304
6.3.6	<i>Standard bar</i>	304
6.3.7	<i>Format bar</i>	305
6.3.8	<i>Project Explorer</i>	306
6.3.8.1	Screen	306
6.3.9	<i>Tool box</i>	309
6.3.9.1	Basic Objects	309
6.3.9.2	Enhanced Objects	353
6.3.9.3	Graphics	372
6.3.9.4	Symbol Factory.....	380
6.3.9.5	Project Tools	388
7.	WEBSERVER	392
7.1	REQUIREMENTS	392
7.2	HOW TO CONFIGURE WEB SERVER SETTINGS	393
7.2.1	<i>How to Configure Static IP Address</i>	393
7.2.2	<i>How to Enable Web Server</i>	394
7.3	HOW TO VIEW RECORDER DATA IN PC VIA WEBSERVER:	395
8.	MODBUS COMMUNICATION	404
8.1	MODBUS ADDRESS MAPPING	404
8.1.1	<i>Input Register (3xxxx) Parameter Table for Modbus RTU Slave / TCP Server</i>	404
8.1.1.1	AI / DI / DO / AO Channel Data (Integer Type).....	404
8.1.1.2	AI / DI / DO / AO Channel Data (Float Type)	406
8.1.1.3	Math Channel Data (Integer Type).....	408
8.1.1.4	Math Channel Data (Float Type)	410
8.1.1.5	PID Process Control Module Data (Integer Type)	411
8.1.1.6	PID Process Control Module Data (Float Type)	421
8.1.1.7	System Information(Integer Type).....	429
8.1.1.8	System Information (Float Type).....	429
8.1.2	<i>Holding Register (4xxxx) Parameter Table for Modbus RTU Slave / TCP Server</i>	430

8.1.2.1	External Channels 2 Bytes Data(Integer Type).....	430
8.1.2.2	External Channels 4 Bytes Data(Integer Type).....	432
8.1.2.3	External Channels 4 Bytes Data (Float Type)	435
8.1.3	<i>Holding Register Parameter Table for Remote Command</i>	437
8.1.3.1	Command Data	437
8.1.3.2	Scale Low (Dword Type).....	445
8.1.3.3	Scale High (Dword Type)	455
8.1.3.4	Others (Word Type)	466
8.2	MODBUS COMMUNICATION	466
8.2.1	<i>Read Input Registers (Function 0x04)</i>	466
8.2.2	<i>Preset (Write) Multiple Registers (Function 0x10)</i>	467
8.2.3	<i>Placing the CRC into message</i>	468
8.3	SAMPLE CODE	468
8.3.1	<i>CRC Generation Function</i>	468
8.3.2	<i>Read Data Function</i>	469
8.3.3	<i>Convert Data Function</i>	470
8.3.4	<i>Read AI Function¹</i>	470
8.3.5	<i>Read Math Function¹</i>	471
8.3.6	<i>Read DI Function¹</i>	472
8.3.7	<i>Read AO Function1</i>	473
8.3.8	<i>Read DO Function1</i>	473
8.3.9	<i>Read External Function1</i>	474
8.4	APPENDIX	474
8.4.1	<i>Modbus RTU Slave / TCP Server Register data type table</i>	474
8.4.2	<i>Inquire AI range</i>	474
8.4.3	<i>AI Conversion Example</i>	475
8.4.4	<i>Math Converion Sample</i>	475
8.4.4.1	Transformation Disable.....	476
8.4.4.2	Transformation as value	476
8.4.4.3	Transformation as Math Channel	477
8.4.5	<i>AO Conversion Example</i>	478
8.4.6	<i>External Channel Conversion for AI channel</i>	478
8.4.7	<i>External Channel Conversion for DI and DO channel</i>	478
8.4.8	<i>External Channel Conversion for AO channel</i>	479
8.4.9	<i>External Channel Conversion for Math channel</i>	479

1. Introduction

1.1 Introduction

The new generation PPS Series paperless recorder has many outstanding features to meet the industry requirements.

1.2 Features

1.2.1 Hardware

The PPS Series hardware has the following unique features.

- ❖ Available in three display sizes 4.3", 5.6" and 12.1"
- ❖ PPS-1000, with a 4.3" display, with 3 or 6 universal analog inputs and 24 Optional External Channels
- ❖ PPS-2000, with a 5.6" display, with 6, 12, 18 or 24 universal analog inputs and 48 Optional External Channels
- ❖ PPS-3000, with a 12.1" display, with 6, 12, 18, 24, 30, 36, 42 or 48 universal analog inputs and 96 Optional External Channels
- ❖ High resolution TFT Colour LCD display with Touch screen
- ❖ 100 millisecond sampling rate and data logging
- ❖ PID Process Control card (PPSPCM) to control the process.
- ❖ High accuracy 24-bit A-D Analog Input
- ❖ 16-bit D-A Analog Output
- ❖ Pulse input through Digital input, maximum 100 Hz.
- ❖ Plug & play I/O cards (AI, AO, DI, and DO) for easy expansion.
- ❖ On-board SD card slot for external storage.
- ❖ Two USB Host Ports for external storage and printer connectivity
- ❖ Ethernet as standard with optional RS-232 or RS422/RS485 communication
- ❖ IP65 water-resistant

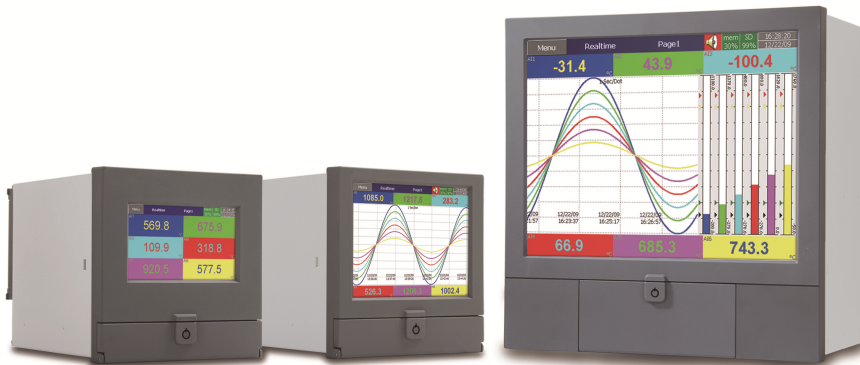

1.2.2 Firmware

The PPS Series recorder has 4 different versions of firmware for the user to select as per the application requirement.

1. Standard Firmware
2. Plus 1 Firmware
3. Plus 2 Firmware
4. Plus 3 Firmware

1.2.3 PC Software

The PPS Series has the below user-friendly software for configuration, analysis, data acquisition and custom display

1. Free Basic Software Historical Viewer for configuration and analysis
2. Extensive Software Data Acquisition Studio for configuration, analysis and data acquisition on PC.
3. Panel Studio Software for Custom display

1.2.4 Firmware and Software Features

The below are the unique features of PPS Series different firmware.

- ❖ Circular Chart in PPS-3000
- ❖ Panel Studio Software for editing and customizing display pages.
- ❖ Display values in Digital, Trend, Bar graph and mix format.
- ❖ Real time and Historical Trends
- ❖ Real time and Historical Alarms
- ❖ Event management, Jobs linked with events
- ❖ Reports (Daily, Weekly and Monthly)
- ❖ Timers, Counters, Totalizers, Math channels
- ❖ FDA 21 CFR part11 compliance
- ❖ Customized messages for alarms
- ❖ Alarms by email directly from paperless recorder
- ❖ Batch control, log data in batches
- ❖ 100 milliseconds data logging and historical data archival tools
- ❖ Display pages rotation
- ❖ Start/Stop data logging functions which can be linked with real time clock or events
- ❖ Search data with reference Time, Period, Tag, Event, Alarm, Remark, Handwrite
- ❖ Export data to Excel and database format(*.csv only)
- ❖ Web server
- ❖ Handwriting function in historical data
- ❖ PID control with Profile function
- ❖ Multiple Languages for users to select
- ❖ Data logging by value change or time base
- ❖ Dynamic Data Exchange via PC software
- ❖ On Field Calibration
- ❖ Direct Printer Connectivity with PDF Printer included
- ❖ USB Barcode Reader Connectivity for Data Entry
- ❖ USB Keyboard and Mouse Connectivity
- ❖ Clock Synchronization via Internet

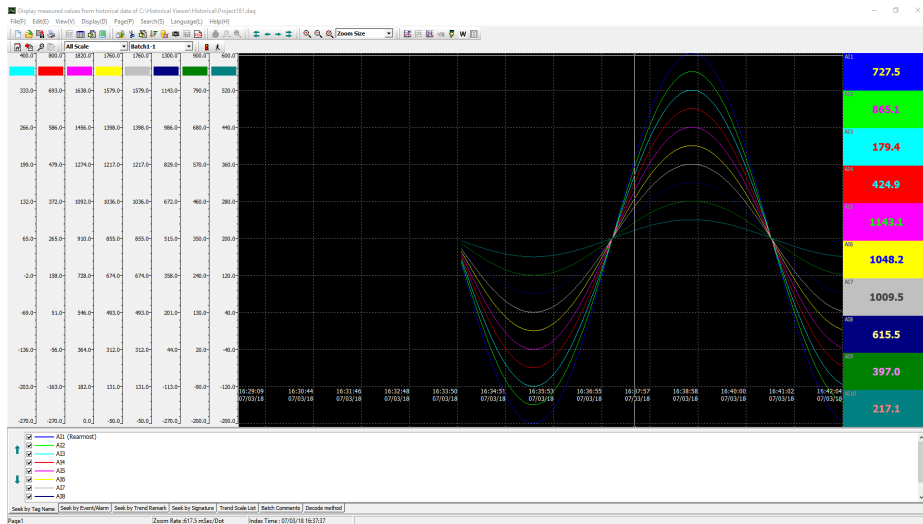

1-1 Historical Viewer Software

The screenshot shows the configuration window for channel AI1. The left sidebar contains a tree view with categories: Channel, AI, DI, Math, AO, DO, External, Display, Batch, Start/Stop, Tools, Timer, Clock, Communication, Instrument, User Account, Demo, Auto-Output, and System Info. The main area is titled 'AI1' and contains the following configuration fields:

- Name: AI1, Desc: , Type: Enable
- Filter: Disable
- Log: Data Type: 2 Byte, Value Range: -3276.8 ~ 3276.7, Trigger: Enable, Method: Instant, Speed: 100 ms/Dot, Modbus Scale: -200.0 ~ 1100.0, Offset: 0.0, Gain: 1.0
- Sensor: Type: Thermocouple J Type, Unit: °C, Range: -200.0 ~ 1100.0
- Events table:

No.	Type	Setpoint	Log	Message	Job1	Job2	Hysteresis	Holding Time
1	H	840.0	Log Alarm		No Action	No Action	0.0	Disable
2	L	60.0	Log Alarm		No Action	No Action	0.0	Disable
3	HH	937.5	Log Alarm		No Action	No Action	0.0	Disable
4	LL	-37.5	Log Alarm		No Action	No Action	0.0	Disable
5	Error	0	Log Alarm		No Action	No Action	0.0	Disable

1-2 Configuration Viewer Software in Historical Viewer Software

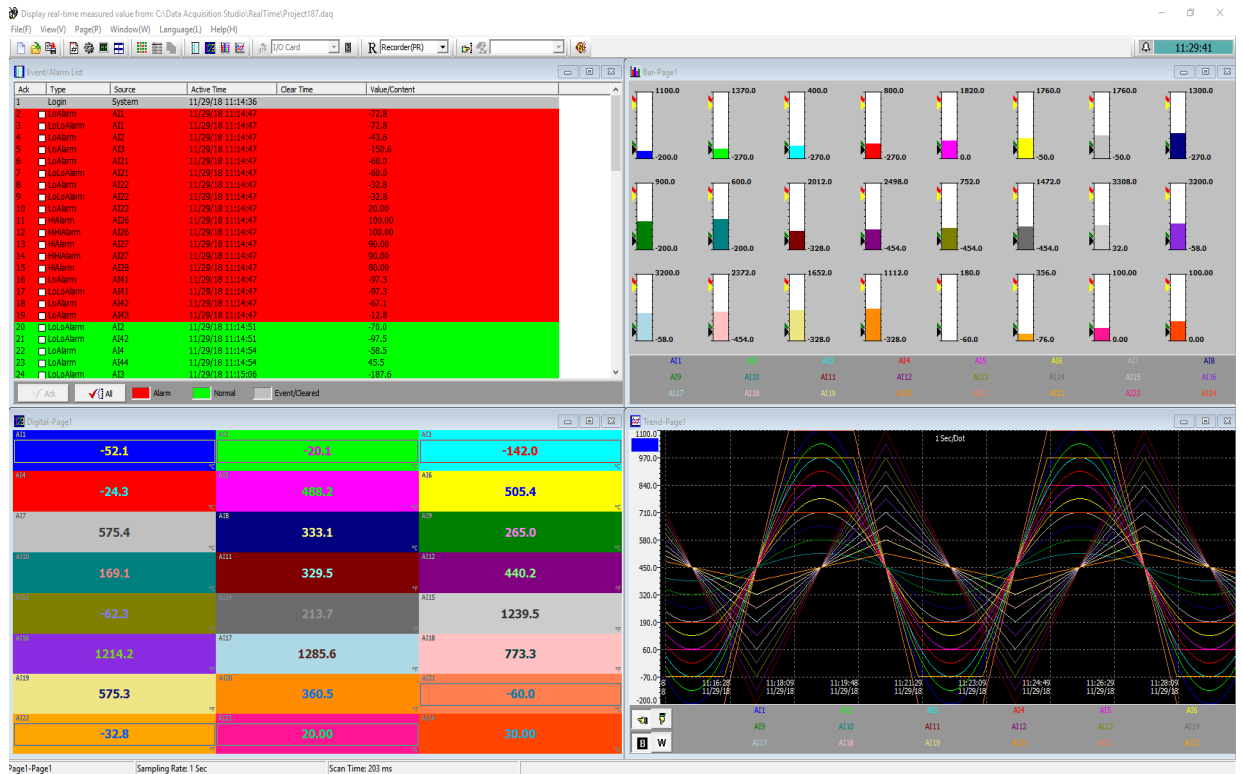

1-3 Real Time Viewer in Data Acquisition Studio Software

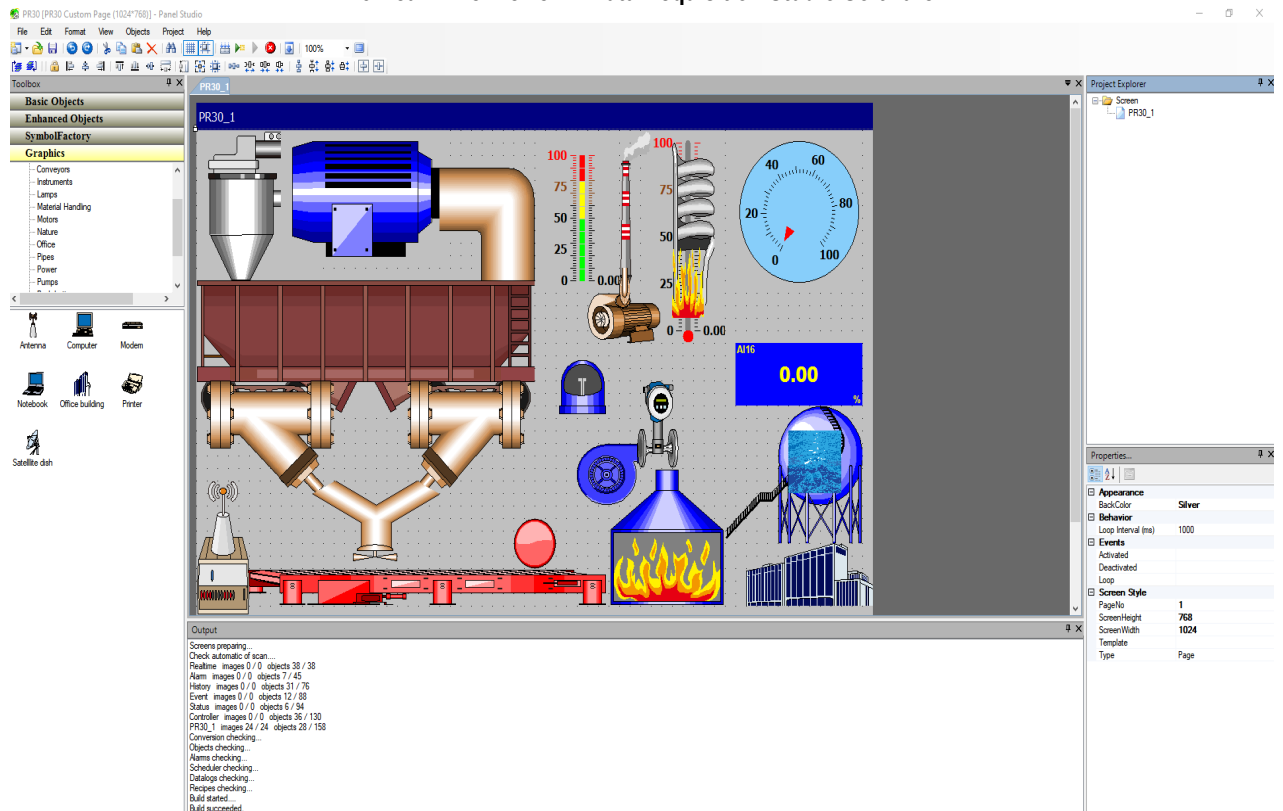

1-4 Panel Studio Software for Custom Display

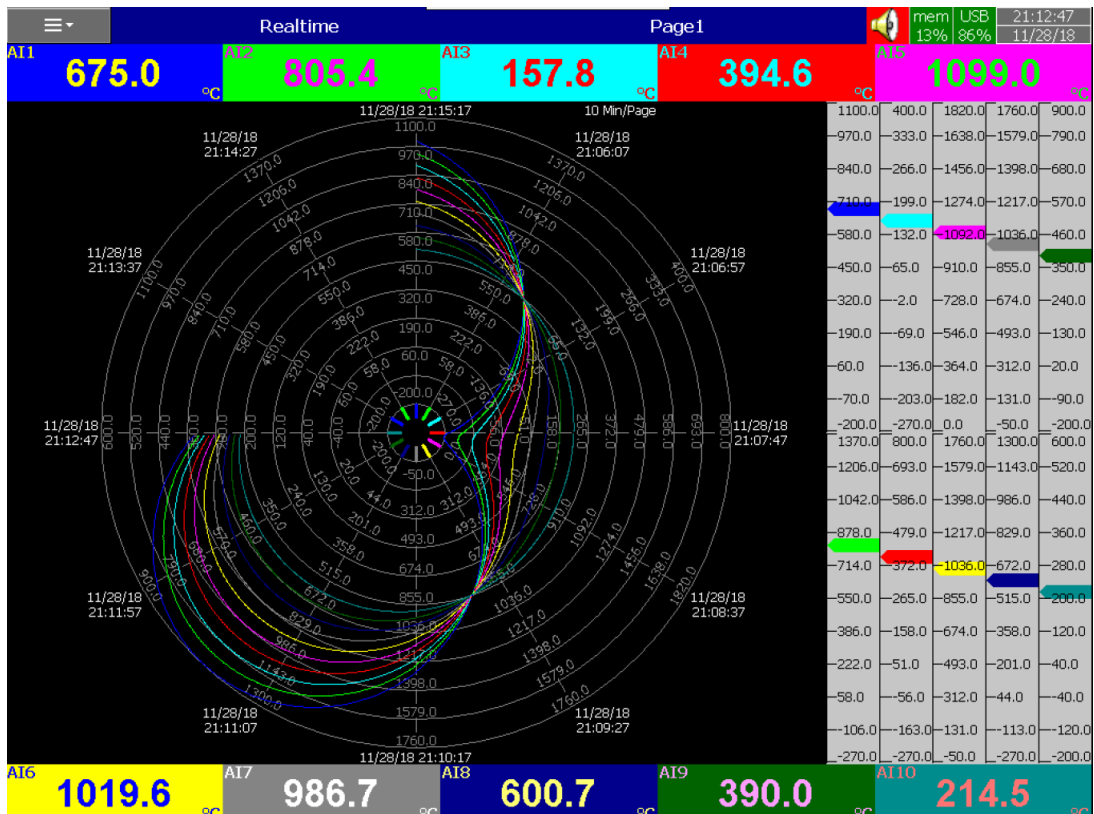

1-5 Circular Chart in PPS-3000

1.3 Comparison of PPS Series Recorders

The below table show the differences between different models of PPS Series recorder.

Description	PPS-1000	PPS-2000	PPS-3000
Display Size	4.3"	5.6"	12.1"
Analog Inputs (Maximum)	6	24	48
Analog Outputs (Maximum)	6	6	12
Digital Inputs (Maximum)	24	24	24
Relay Outputs (Maximum)	24	24	24
PID Process Control Card	4	4	8
Math Channels (Maximum)	15	40	60
External Channels (Other devices via Modbus)	24	48	96
Total Pages	8	20	21
Pens/Page (Maximum)	6	6	10
Batches(Maximum)	1	1	1

1-1 Comparison of PPS-1000, PPS-2000 and PPS-3000

1.4 Expandable Input and Output cards

There are 4 rear expansion slots in PPS-1000 and PPS-2000 and 16 rear expansion slots in PPS-3000 available for expansion with the following plug and play I/O Cards.

1.4.1 Analog Input cards (part number PPS90001 & PPS90002)

These two cards are used for 3 or 6-channel analog inputs. Each input is isolated from each other to avoid noise and to ensure stable measurement.

AI206
6 AI (6 analog inputs)



AI203
3 AI (3 analog inputs)

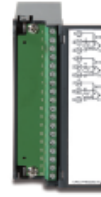

1.4.2 Relay Output card (PPS90003)

Each card includes 6 relay outputs. The relay contacts are rated 5 Amp/240 VAC.

RO206
6 relay outputs



1.4.3 Digital Input card (PPS90004)

Each card includes 6 channels. Logic Low: -5V minimum, 0.8V maximum, Logic High: 3.5V minimum, 24V maximum

DI206
6 DI (6 digital inputs)



1.4.4 Combination Relay Output and Digital Input Card (PPS90005)

Each Card includes 3 digital Inputs and 3 Relay Outputs. For Digital Inputs, Logic Low: -5V minimum, 0.8V maximum, Logic High: -3.5V minimum, 24V maximum. For Relay Outputs, the Contacts are rated 5 Amp/240 VAC

RD233
3 relays + 3DI



1.4.5 Analog Output cards (PPS90006)

Each card includes 6 channels. They are used for 4-20mA, 0-20mA current output, 0-5V, 1-5V, 0-10VDC voltage output.

AO206
6 AO (6 analog outputs)



1.4.6 Process Control card (PPSPCM)

Each card includes 2 Analog channels and 5 Digital Channels (1-Digital input, 2-Digital outputs, 2-Digital Outputs for Alarms).

PC201
single loop process control



1.5 Communication

The standard communication interface is Ethernet with protocol IEEE 802.3 – 10/100 Base T. Other options are RS-232 / RS-422 / RS-485. Details are explained in [Chapter 2.4.8 - RS-232, RS-422, RS-485 wiring.](#)

1.6 External Storage media

The recorder has 256MB internal memory to store the data. There are two types of External storage media available for the recorder to dump the stored data from internal memory. They are SD card and USB. Only one storage media can be used at a time in the recorder.

If the recorder is used with **6-channel inputs**, the below chart shows the maximum no of days historical data can be stored based on available memory.

SD card	16GB	32GB
Log speed		
1 second	15, 808 days	31,616 days
10 seconds	158,032 days	316,064 days
120 seconds	1,896,304 days	3,792,608 days

* The above is an approximation, each record of data uses 2 or 4 bytes of memory depending on the data type.

For ex: Selected data size = 2 bytes

If the Log Speed (the recording speed of measured data) is set to the speed at 1 second per data, then for a six channels, a 16GB SD Card will last approximately 15, 808 days [16GB/ (2 bytes x 24 hours x 60 minutes x 60 seconds x 6 Channels)].

The following formula is to calculate how many days a USB disk can do saving before it is full.

No of days = (The capacity of SD card memory x Log Speed) / (2 x # of hours per day x 60 x 60 x Number of channels)

If the user is using USB to dump the data then it is necessary to insert USB memory back to recorder after loading recorded data onto PC. Otherwise the dumping process will fail and the oldest data will be deleted once the internal memory is full. The recorder will do automatic dumping process when the internal memory is occupied by 85%.

1.7 Smart Mechanism

The recorded data is stored in the manufacturer's special binary format. It is not possible to manipulate or modify the recorded data. This feature fully guarantees the security of the data.

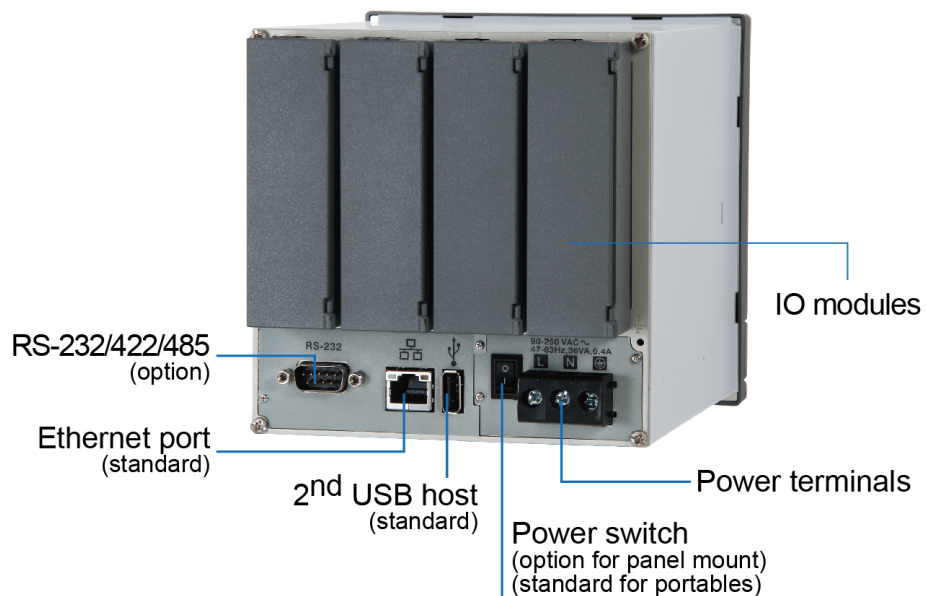
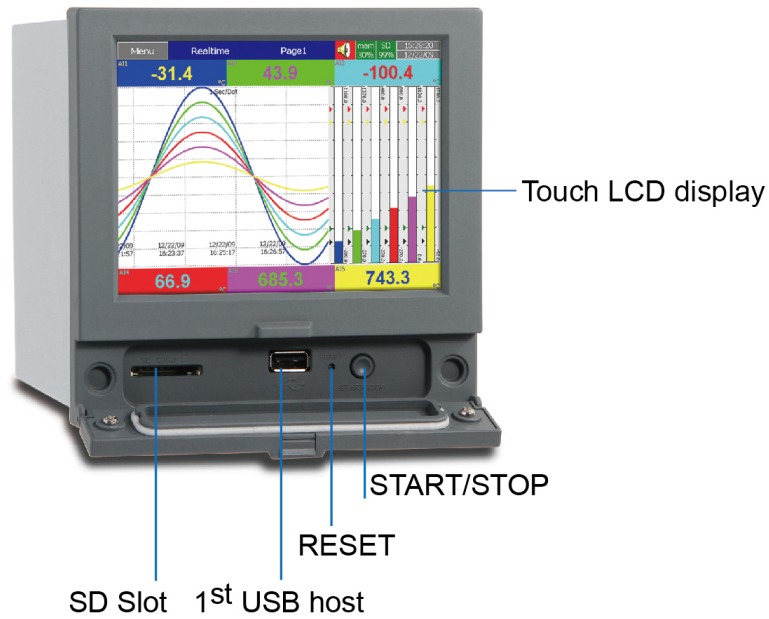

1.8 Ordering Code

1.8.1 PPS-1000 Ordering code

PPS-1000-03 (3 Analog Inputs)

Other Inputs and Outputs

- 0: none
- 6: 3 relays + 3 DI

PPS-1000-06 (6 Analog Inputs)

Other Inputs and Outputs

- 0: none
- 1: 6 relays
- 3: 6 DI
- 6: 3 relays + 3 DI
- 7: 6 relays + 6 DI

Power

- A: 90-250 VAC, 50/60 Hz
- D: 11-36 VDC

Communication

- 0: standard Ethernet interface
- 1: Ethernet + RS-232
- 2: Ethernet + RS-422/485

Firmware

- 0: Standard Version with Mathematic Functions
- 1: Plus Version 1 with external channels, batch & FDA21 CFR part11
- 2: Plus Version 2 with editable custom display and Panel Studio software
- 3: Plus Version 3- includes Plus Version 1+2 above

PC Software

- 1: Free Basic Software of Historical Viewer and Configuration
- 2: Extensive software Data Acquisition Studio
(Real Time Viewer + Historical Viewer + Configuration)

Mounting types, Power Cord & Switch

- 0: panel mount, no power cord, no power switch
- 1: panel mount, no power cord, power switch
- 2: portable, UL & CSA power cord, power switch
- 3: portable, VDE power cord, power switch
- 4: portable, SAA power cord, power switch
- 5: portable, BS power cord, power switch
- 6: portable, no power cord, power switch
- 7: Panel mount, UL & CSA power cord, power switch
- 8: Panel mount, VDE power cord, power switch
- 9: Panel mount, SAA power cord, power switch
- A: Panel mount, BS power cord, power switch

Special options

- 00: none
- S1: 16G SD card
- S2: 32G SD card
- 10: Process control card
- 11: Process control card + 16G SD card
- 12: Process control card + 32G SD card

Note:

DI- Digital Input

Process Control card Ordering code needs to be chosen after special options 10, 11, 12 been selected

1.8.2 PPS-2000 Ordering code

PPS-2000-03 (3 Analog Inputs)

Other Inputs and Outputs

- 0: none
- 6: 3 relays + 3 DI
- C: 3 relays + 3 DI + 6 AO

PPS-2000-06 (6 Analog Inputs)

Other Inputs and Outputs

- 0: none
- 1: 6 Relays
- 3: 6 DI
- 5: 6 AO
- 6: 3 relays + 3 DI
- 7: 6 relays + 6 DI
- A: 6 relays + 6 AO
- B: 6 DI + 6 AO
- C: 3 relays + 3 DI + 6 AO
- D: 6 relays + 6 DI + 6 AO

PPS-2000-12 (12 Analog Inputs)

Other Inputs and Outputs

- 0: none
- 1: 6 Relays
- 2: 12 Relays
- 3: 6 DI
- 4: 12 DI
- 5: 6 AO
- 6: 3 relays + 3 DI
- 7: 6 relays + 6 DI
- 8: 9 relays + 3 DI
- 9: 3 relays + 9 DI
- A: 6 relays + 6 AO
- B: 6 DI + 6 AO
- C: 3 relays + 3 DI + 6 AO

PPS-2000-18 (18 Analog Inputs)

Other Inputs and Outputs

- 0: none
- 1: 6 Relays
- 3: 6 DI
- 5: 6 AO
- 6: 3 relays + 3 DI

PPS-2000-24 (24 Analog Inputs)

Other Inputs and Outputs

- 0: none

Power

- A: 90-250 VAC, 50/60 Hz
- D: 11-36 VDC

Communication

- 0: standard Ethernet interface
- 1: Ethernet + RS-232
- 2: Ethernet + RS-422/485

Firmware

- 0: Standard Version with Mathematic Functions
- 1: Plus Version 1 with external channels, batch & FDA 21 CFR part11
- 2: Plus Version 2 with editable custom display and Panel Studio software
- 3: Plus Version 3 - includes Plus Version 1+2 above

PC Software

- 1: Free Basic Software of Historical Viewer and Configuration
- 2: Extensive software Data Acquisition Studio
(Real Time Viewer + Historical Viewer + Configuration)

Special options
(Select from the option
in the next page)

Mounting types, Power Cord & Switch
(Select from the option in the next page)

Mounting types, Power Cord & Switch

- 0: panel mount, no power cord, no power switch
- 1: panel mount, no power cord, power switch
- 2: portable, UL & CSA power cord, power switch
- 3: portable, VDE power cord, power switch
- 4: portable, SAA power cord, power switch
- 5: portable, BS power cord, power switch
- 6: portable, no power cord, power switch
- 7: Panel mount, UL & CSA power cord, power switch
- 8: Panel mount, VDE power cord, power switch
- 9: Panel mount, SAA power cord, power switch
- A: Panel mount, BS power cord, power switch

Special options

- 00: none

S1: 16G SD card

S2: 32G SD card

10: Process control card

11: Process control card + 16G SD card

12: Process control card + 32G SD card

Note:

DI- Digital Input

AO- Analog Output

Process Control card Ordering code needs to be chosen after special options 10, 11, 12 been selected

Process control card cannot be chosen together with

5: 6AO,

A: 6 relays + 6AO

B: 6DI +6AO

C: 3 relays + 3DI + 6AO

D: 6 relays + 6DI + 6AO

Nor with 24 analog inputs

1.8.3 PPS-3000 Ordering code

- PPS-3000-06 (6 Analog Inputs) -
- PPS-3000-12 (12 Analog Inputs)
- PPS-3000-18 (18 Analog Inputs)
- PPS-3000-24 (24 Analog Inputs)
- PPS-3000-30 (30 Analog Inputs)
- PPS-3000-36 (36 Analog Inputs)
- PPS-3000-42 (42 Analog Inputs)
- PPS-3000-30 (48 Analog Inputs)



- Relay _____
- 0: none
 - 1: 6 Relays
 - 2: 12 Relays
 - 3: 18 Relays
 - 4: 24 Relays

- Digital Inputs _____
- 0: none
 - 1: 6 Channels
 - 2: 12 Channels
 - 3: 18 Channels

- Analog Outputs _____
- 0: none
 - 1: 6 Channels
 - 2: 12 Channels

- Power _____
- A: 90-250 VAC, 50/60 Hz
 - D: 11-36 VDC (UL Certification Not available)

- Communication _____
- 0: standard Ethernet interface
 - 1: Ethernet + RS-232
 - 2: Ethernet + RS-422/485

- Firmware _____
- 0: Standard Version with Mathematic Functions
 - 1: Plus Version 1 with external channels, batch & FDA 21 CFR part11
 - 2: Plus Version 2 with editable custom display and Panel Studio software
 - 3: Plus Version 3- includes Plus Version 1+2 above

- PC Software _____
- 1: Free Basic Software of Historical Viewer and Configuration
 - 2: Extensive software Data Acquisition Studio
(Real Time Viewer + Historical Viewer + Configuration)

- Mounting types, Power Cord & Switch _____
- 0: panel mount, no power cord, no power switch
 - 1: panel mount, no power cord, power switch
 - 2: portable, UL & CSA power cord, power switch
 - 3: portable, VDE power cord, power switch
 - 4: portable, SAA power cord, power switch
 - 5: portable, BS power cord, power switch
 - 6: portable, no power cord, power switch
 - 7: Panel mount, UL & CSA power cord, power switch
 - 8: Panel mount, VDE power cord, power switch
 - 9: Panel mount, SAA power cord, power switch
 - A: Panel mount, BS power cord, power switch

- Special options _____
- 00: none
 - S1: 16G SD card
 - S2: 32G SD card

1.8.4 PPSPCM Ordering code

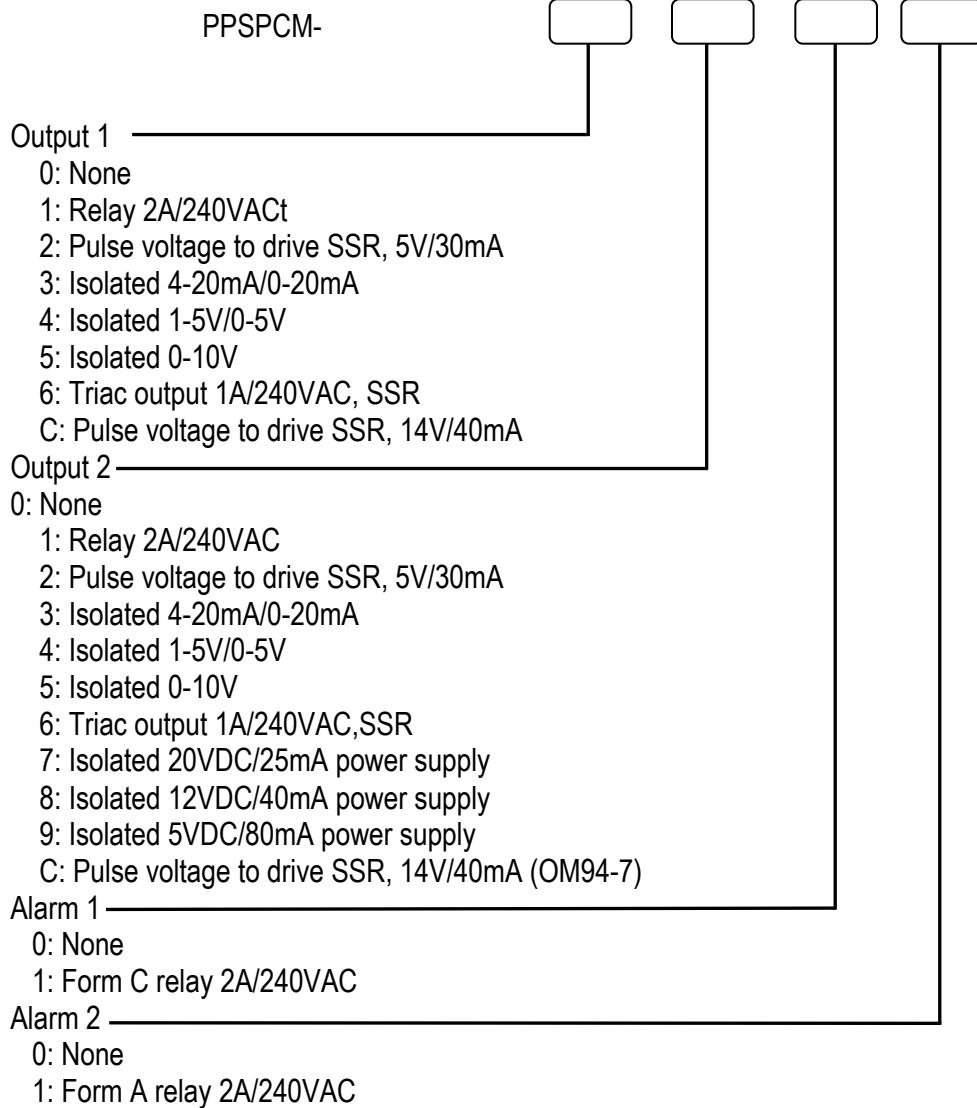

1.8.5 Accessories

Part no	Description
PPS90002	3-channel analog input card (TC, RTD, mA, V, mV)
PPS90001	6-channel analog input card (TC, RTD, mA, V, mV)
PPSPCM	PID process control card
PPS90003	6-channel relay output card
PPS90004	6-channel digital input card
PPS90005	3-channel relay output and 3-channel digital input card
PPS90006	6-channel analog output card
IF232	RS-232 communication module for PPS-1000 and PPS-2000
IF485	RS-422/485 communication module for PPS-1000 and PPS-2000
IF232A	RS-232 communication module for PPS-3000
IF485A	RS-422/485 communication module for PPS-3000
PM201	90-250VAC 47-63Hz panel mount power supply board without power Switch for PPS-1000 and PPS-2000
PM202	90-250VAC 47-63Hz panel mount power supply board with power switch For PPS-1000 and PPS-2000

Part no	Description
PM203	90-250VAC 47-63Hz portable power supply board with power switch for PPS-1000 and PPS-2000
PM211	11-36VDC panel mount power supply board without power switch for PPS-1000 and PPS-2000
PM212	11-36VDC panel mount power supply board with power switch for PPS-1000 and PPS-2000
PM213	11-36VDC portable power supply board with power switch for PPS-1000 and PPS-2000
PM301	90-250VAC 47-63Hz panel mount power supply board without power switch for PPS-3000
PM302	90-250VAC 47-63Hz panel mount power supply board with power switch for PPS-3000
PM303	90-250VAC 47-63Hz portable power supply board with power switch for PPS-3000
PM311	11-36VDC panel mount power supply board without power switch for PPS-3000
PM312	11-36VDC panel mount power supply board with power switch for PPS-3000
PM313	11-36VDC portable power supply board with power switch for PPS-3000

1-2 Accessories Ordering Code

Note:

- ❖ The rear slots of the recorder will accept certain input or output cards only in any combination based on selected model.
- ❖ The basic PC software is supplied free with the recorder. There is an additional charge for the extensive Data Acquisition Software and communication ports of RS-232/422/485.
- ❖ The Ordering Code for various standard model Recorders with an AC supply and without any additional options are as follows:
PPS-1000-03- 0A001000
PPS-2000-03- 0A001000
PPS-3000-06- 000A001000

1.9 Specifications

1.9.1 General Specifications

	PPS-1000	PPS-2000	PPS-3000
Number of Analog Input	3, 6	3, 6, 12, 18, 24	6, 12, 18, 24, 30, 36, 42, 48
Input Signals	Thermocouples: J, K, T, E, B, R, S, N, L, U, P, W5, W3, LR, A1, A2, A3, M RTD: PT50, PT100, PT200, PT500, PT1000($\alpha=0.00385$), PT50, PT100($\alpha=0.00391$), JPT50, JPT100, JPT200, JPT500, JPT1000($\alpha=0.003916$), Cu10($\alpha=0.00427$), Cu50, Cu100($\alpha=0.00426, 0.00428$), Ni100, Ni200, Ni500, Ni1000($\alpha=0.00617$), Current(mA), Voltage(Volts, mV)		
Fastest Sampling rate	100msec/dot, Default setting : 1sec/dot		
Calibration Correction	On-site Calibration possible or using Offset and Gain for correction		
Power	90-250VAC, 47-63Hz, 52VA, 26W maximum 11-36VDC, 26VA, 26W maximum	90-250VAC, 47-63Hz, 110VA, 62W maximum, 11-36VDC, 62VA, 62W maximum (UL Certification Not available)	
Display Size	4.3"	5.6"	12.1"
Display Type	65K Colour, TFT Touch Screen		
Display Resolution	480 x 272	640 x 480	1024 x 768

	PPS-1000	PPS-2000	PPS-3000
Backlight	LED		
Display MTBF @25°C	30000 Hours		60000 Hours
CPU	ARM Cortex-A8, 1GHz		
Internal Memory	256MB		
External Storage	Max. Up to 32GB SD Card or USB Disk		
SD Card Slot	Standard one slot at Front		
USB Slot	Standard one USB slot in front and one USB slot in the rear		
Pulse Input	Optional DI card support pulse Input up to 100Hz		
PID Process Control	PID, Ramp & Dwell		
Math Channel	Available by Standard version		
External Channel, Batch, Custom Display, FDA 21 CFR Part 11	Available by plus versions		
Multilingual	Convenient for local users by offering languages in Brazil Portuguese, Chinese (Simplified, Traditional), Czech, Danish, Dutch, English, French, German, Greek, Italian, Japanese, Korean, Polish, Portuguese, Russian, Spanish, Swedish, Thai, Turkish. Other Languages negotiable.		
Screen saver, Email	Available by Standard version		
Ethernet	Standard Ethernet Port. Modbus TCP/IP (Server by default, Client available with plus 1 version)		
RS-232/422/485	Optional Rs232 or Optional RS422/485. Modbus RTU (Slave by default, Master available with plus 1 version)		
PC Software	Standard: Historical Viewer + Configuration Optional: Extensive Software Data Acquisition Studio for real time monitoring		

1.9.2 Analog Input Specifications (PPS90002 & PPS90001)

Channels: PPS90002 ~ 3 channels, PPS90001 ~ 6 channels

Resolution: 24 bits

Sampling Rate: 10 times/ second (100milliseconds)

Maximum Rating:

- ❖ RTD input $\pm 20V$
- ❖ Thermocouple and Voltage input $\pm 50V$
- ❖ mA input $\pm 10V$

Temperature Effect:

- ❖ $\pm 0.1\mu V \pm 15PPM$ of reading for all inputs except mA
- ❖ $\pm 30PPM$ of reading for mA input

Sensor Lead Resistance Effect:

- ❖ **Thermocouple:** 0.32PPM of reading/ Ω
- ❖ **3-wire RTD:** 2.6°C/ Ω of resistance difference of two leads (Based on °C measurement temperature for PT100)
- ❖ **2-wire RTD:** 2.6°C/ Ω of resistance sum of two leads (Based on °C measurement temperature for PT100)

Burn-out Current: 10uA

Common Mode Rejection Ratio (CMRR): 120dB

Normal Mode Rejection Ratio (NMRR): 55dB

Isolation Breakdown Voltage between channels: 1500VAC min.

Sensor Break Detection:

- ❖ Sensor opened for TC, RTD and mV inputs
- ❖ Below 1 mA for 4-20mA input

- ❖ Below 0.25V for 1-5V inputs
- ❖ Not available for other inputs

Sensor Break Responding Time:

- ❖ Within 1 seconds for TC, RTD and mV inputs
- ❖ 0.1 second for 4-20 mA and 1-5V inputs

Input Characteristics:

Type	Range	Accuracy at 25 °C	Input Impedance
J	-120 ~ 1000 °C (-184 ~ 1832 °F)	±1 °C	3.12MΩ
K	-200 ~ 1370 °C (-328 ~ 2498 °F)	±1 °C	3.12MΩ
T	-250 ~ 400 °C (-418 ~ 752 °F)	±1 °C	3.12MΩ
E	-100 ~ 900 °C (-148 ~ 1652 °F)	±1 °C	3.12MΩ
B	0 ~ 1820 °C (32 ~ 3308 °F)	±2 °C (200 ~ 1820 °C)	3.12MΩ
R	0 ~ 1768 °C (32 ~ 3214 °F)	±2 °C	3.12MΩ
S	0 ~ 1768 °C (32 ~ 3214 °F)	±2 °C	3.12MΩ
N	-250 ~ 1300 °C (-418 ~ 2372 °F)	±1 °C	3.12MΩ
L	-200 ~ 900 °C (-328 ~ 1652 °F)	±1 °C	3.12MΩ
U	-200 ~ 600 °C (-328 ~ 1112 °F)	±1 °C	3.12MΩ
P	0 ~ 1395 °C (32~2543 °F)	±1 °C	3.12MΩ
W5 or C	0 ~ 2315 °C (32 ~ 4199 °F)	±1 °C	3.12MΩ
W3	0 ~ 2315 °C (32 ~ 4199 °F)	±1 °C	3.12MΩ
LR	-200 ~ 800 °C (-328 ~ 1472 °F)	±1 °C	3.12MΩ
A1	0 ~ 2500 °C (-32 ~ 4532 °F)	±1 °C	3.12MΩ
A2	0 ~ 1800 °C (-32 ~ 3272 °F)	±1 °C	3.12MΩ
A3	0 ~ 1800 °C (-32 ~ 3272 °F)	±1 °C	3.12MΩ
M	-200 ~ 100 °C (-328 ~ 212 °F)	±1 °C	3.12MΩ
PT50 (α = 0.00385)	-200 ~ 850 °C (-328 ~ 1562 °F)	±0.4 °C	2.0KΩ
PT100 (α = 0.00385)	-200 ~ 850 °C (-328 ~ 1562 °F)	±0.4 °C	2.0KΩ

Type	Range	Accuracy at 25 °C	Input Impedance
PT200 ($\alpha = 0.00385$)	-200 ~ 850 °C (-328 ~ 1562 °F)	±0.4 °C	2.0KΩ
PT500 ($\alpha = 0.00385$)	-200 ~ 850 °C (-328 ~ 1562 °F)	±0.4 °C	2.0KΩ
PT1000 ($\alpha = 0.00385$)	-200 ~ 350 °C (-328 ~ 662 °F)	±0.4 °C	2.0KΩ
PT50 ($\alpha = 0.00391$)	-200 ~ 850 °C (-328 ~ 1562 °F)	±0.4 °C	2.0KΩ
PT100 ($\alpha = 0.00391$)	-200 ~ 850 °C (-328 ~ 1562 °F)	±0.4 °C	2.0KΩ
JPT50 ($\alpha = 0.003916$)	-200 ~ 600 °C (-328 ~ 1112 °F)	±0.4 °C	2.0KΩ
JPT100 ($\alpha = 0.003916$)	-200 ~ 600 °C (-328 ~ 1112 °F)	±0.4 °C	2.0KΩ
JPT200 ($\alpha = 0.003916$)	-200 ~ 600 °C (-328 ~ 1112 °F)	±0.4 °C	2.0KΩ
JPT500 ($\alpha = 0.003916$)	-200 ~ 600 °C (-328 ~ 1112 °F)	±0.4 °C	2.0KΩ
JPT1000 ($\alpha = 0.003916$)	-200 ~ 350 °C (-328 ~ 662 °F)	±0.4 °C	2.0KΩ
Cu50 ($\alpha = 0.00426$)	-50 ~ 200 °C (-58 ~ 392 °F)	±0.4 °C	2.0KΩ
Cu100 ($\alpha = 0.00426$)	-50 ~ 200 °C (-58 ~ 392 °F)	±0.4 °C	2.0KΩ
Cu50 ($\alpha = 0.00428$)	-180 ~ 200 °C (-292 ~ 392 °F)	±0.4 °C	2.0KΩ
Cu100 ($\alpha = 0.00428$)	-180 ~ 200 °C (-292 ~ 392 °F)	±0.4 °C	2.0KΩ
Ni100 ($\alpha = 0.00617$)	-60 ~ 180 °C (-76 ~ 356 °F)	±0.4 °C	2.0KΩ
Ni200 ($\alpha = 0.00617$)	-60 ~ 180 °C (-76 ~ 356 °F)	±0.4 °C	2.0KΩ
Ni500 ($\alpha = 0.00617$)	-60 ~ 180 °C (-76 ~ 356 °F)	±0.4 °C	2.0KΩ
Ni1000 ($\alpha = 0.00617$)	-60 ~ 180 °C (-76 ~ 356 °F)	±0.4 °C	2.0KΩ
Cu10 ($\alpha = 0.00427$)	-200 ~ 260 °C (-328 ~ 500 °F)	±0.1 °C	2.0KΩ
±20mA	-26 ~ 26mA	±0.05%	75Ω
±60mV	-122 ~ 122mV	±0.05%	3.12MΩ
±200mV	-243 ~ 243mV	±0.05%	3.12MΩ
±1V	-1.58 ~ 1.58mV	±0.05%	3.12MΩ
±2V	-3.16 ~ 3.16mV	±0.05%	3.12MΩ
±6V	-6.32 ~ 6.32V	±0.05%	3.12MΩ
±20V	-25.3 ~ 25.3V	±0.05%	3.12MΩ

Type	Range	Accuracy at 25 °C	Input Impedance
±50V	-50.6 ~ 50.6V	±0.05%	3.12MΩ
0.4 ~ 2V	-3.16 ~ 3.16V	±0.05%	3.12MΩ
1 ~ 5V	-6.32 ~ 6.32V	±0.05%	3.12MΩ

1.9.3 Digital Input Specifications (PPS90004 & PPS90005)

Channels:

PPS90004: 6 Channels per card,

PPS90005: 3 Channels per card

Logic Low: -5V minimum, 0.8V maximum

Logic High: 3.5V minimum, 24V maximum

External pull-down Resistance: 1KΩ maximum

External pull-up Resistance: 1.5MΩ minimum

1.9.4 Relay Output Specifications (PPS90003 & PPS90005)

Channels:

PPS90003: 6 Channels per card,

PPS90005: 3 Channels per card

Contact Form: N.O. & N.C. (Form C)

Relay Rating: 5A/240 VAC, life cycles 200,000 for resistive load

1.9.5 Analog Output Specifications (PPS90006)

Channels: 6 Channels per card

Output signal: 4-20mA, 0-20mA, 0-5V, 1-5V, 0-10V

Resolution: 16 bits

Accuracy: ±0.05% of Span ±0.0025% /°C

Load Resistance: 0-500Ω (current), 10KΩ minimum (voltage)

Output Regulation: 0.01% for full load change

Output Setting Time: 0.1 second (stable to 99.9%)

Isolation Breakdown Voltage: 1500VAC at 50/60Hz for 1 minute

Integral Linearity Error: ±0.005% of Span

Temperature Effect: ±0.0025% of Span /°C

Note:

There are DIP switches available on the AO card to select the output type and the default setting is SET to Voltage output. For Current (mA) Output, SET 1 to 5 (ON) and 6 to 8 (OFF). For more details refer to [Chapter 5.1.4](#)

1.9.6 PID Process Control card Specifications (PPSPCM)

1.9.6.1 Input1

Resolution: 18 bits

Sampling Rate: 5 times / second

Maximum Rating: -2 VDC minimum, 12 VDC maximum (1 minute for mA input)

Temperature Effect: 1.5uV/°C for all inputs except mA input, ±3.0uV/°C for mA input

Sensor Lead Resistance Effect:

❖ **Thermocouple:** 0.2uV/Ω

❖ **3-wire RTD:** 2.6°C/Ω of resistance difference of two leads

❖ **2-wire RTD:** 2.6°C/Ω of resistance sum of two leads

Burn-out Current: 200nA

Common Mode Rejection Ratio (CMRR): 120dB

Normal Mode Rejection Ratio (NMRR): 55dB

Sensor Break Detection: Sensor Open for Thermocouple, RTD and mV inputs

Sensor short for RTD input

Below 1 mA for 4-20 mA input

Below 0.25V for 1 - 5 V input

Not available for other inputs.

Sensor Break Responding Time:

❖ Within 4 seconds for TC, RTD and mV inputs

❖ 0.1 second for 4-20 mA and 1 - 5 V inputs

Input 1 Characteristics:

Type	Range	Accuracy @ 25°C	Input Impedance
J	-120°C to 1000°C (-184°F to 1832°F)	±2°C	2.2 MΩ
K	-200°C to 1370°C (-328°F to 2498°F)	±2°C	2.2 MΩ
T	-250°C to 400°C (-418°F to 752°F)	±2°C	2.2 MΩ
E	-100°C to 900°C (-148°F to 1652°F)	±2°C	2.2 MΩ
B	0°C to 1800°C (32°F to 3272°F)	±2°C (200°C to 1800°C)	2.2 MΩ
R	0°C to 1767.8°C (32°F to 3214°F)	±2°C	2.2 MΩ
S	0°C to 1767.8°C (32°F to 3214°F)	±2°C	2.2 MΩ
N	-250°C to 1300°C (-418°F to 2372°F)	±2°C	2.2 MΩ
L	-200°C to 900°C (-328°F to 1652°F)	±2°C	2.2 MΩ
PT100(DIN)	-210°C to 700°C (-346°F to 1292°F)	±0.4°C	1.3KΩ
PT100(JIS)	-200°C to 600°C (-328°F to 1112°F)	±0.4°C	1.3Ω
mV	-8mV to 70mV	±0.05%	2.2 MΩ
mA	-3mA to 27mA	±0.05%	70.5Ω
V	-1.3V to 11.5V	±0.05%	302KΩ

1.9.6.2 Input 2

Resolution: 18 bits

Sampling Rate: 5 times / second

Maximum Rating: -2 VDC minimum, 12 VDC maximum (1 minute for mA input)

Temperature Effect: 1.5uV/°C for all inputs except mA input, ±3.0uV/°C for mA input

Common Mode Rejection Ratio (CMRR): 120dB

Normal Mode Rejection Ratio (NMRR): 55dB

Sensor Break Detection:

❖ Below 1 mA for 4-20 mA input

❖ Below 0.25V for 1 - 5 V input

❖ Not available for other inputs

Sensor Break Responding Time: 0.5 Seconds

Input 2 Characteristics:

Type	Range	Accuracy @ 25°C	Input Impedance
CT94-1	0.0 to 50.0 A	±2% of Reading ±0.2A	302KΩ
mA	-3mA to 27mA	±0.05%	70.5Ω+(0.8V/Input Current)
V	-1.3V to 11.5V	±0.05%	302KΩ

1.9.6.3 Input3 (Event Input)

Logic low: -10V minimum, 0.8V maximum

Logic high: 2V minimum, 10V maximum

External pull-down Resistance: 400 KΩ maximum

External pull-up Resistance: 1.5 MΩ minimum

Functions:

Select second set point and/or PID, Reset alarm 1 and/or alarm 2, Disable output 1 and/or output 2, Remote lockout.

1.9.6.4 Output1/Output2

1. Relay Rating:

2A/240 VAC, life cycles 200,000 for Resistive load

2. Pulsed Voltage:

Source Voltage 5V, current limiting resistance 66Ω

3. Linear Output:

Resolution: 15 bits

Output Regulation: 0.01 % for full load change

Output Settling Time: 0.1 sec. (stable to 99.9 %)

Isolation Breakdown Voltage: 1000 VAC

Temperature Effect: ±0.0025 % of SPAN /°C

Linear Output Characteristics:

Type	Zero Tolerance	Span Tolerance	Load Capacity
4 to 20mA	3.8-4 mA	20-21 mA	500 Ω max
0 to 20mA	0 mA	20-21 mA	500 Ω max
0 to 5V	0 V	5 -5.25 V	10KΩ min
1 to 5V	0.95 to 1V	5 -5.25 V	10KΩ min
0 to 10V	0 V	10 - 10.5 V	10KΩ min

4. Triac (SSR) Output:

Rating: 1A / 240 VAC

Inrush Current: 20A for 1 cycle

Min. Load Current: 50 mA RMS

Max. Off-state Leakage: 3 mA RMS

Max. On-state Voltage: 1.5 V RMS

Insulation Resistance: 1000 MΩ minimum at 500 VDC

Dielectric Strength: 2500 VAC for 1 minute

SSR Output Characteristics:

Type	Tolerance	Maximum Output Current	Ripple Voltage	Isolation Barrier
20V	±0.5 V	25 mA	0.2 Vp-p	500 VAC
12V	±0.3 V	40 mA	0.1 Vp-p	500 VAC

Type	Tolerance	Maximum Output Current	Ripple Voltage	Isolation Barrier
5V	±0.15 V	80 mA	0.05 Vp-p	500 VAC

1.9.6.5 Alarm 1/ Alarm 2

Alarm 1 Relay: Form A or Form B, Max. Rating 2A/240VAC, life cycles 100,000 for resistive load

Alarm 2 Relay: Form A, Max. Rating 2A/240VAC, life cycles 200,000 for resistive load

Alarm Mode: Normal, Latching, Hold, Latching / Hold

Dwell Timer: 0 - 6553.5 minutes

Alarm Functions:

Dwell timer, Deviation High / Low Alarm, Deviation Band High / Low Alarm, PV1 High / Low Alarm, PV2 High / Low Alarm, PV1 or PV2 High / Low Alarm, PV1-PV2 High / Low Alarm, Loop Break Alarm, Sensor Break Alarm

1.9.6.6 Control Mode

Output 1: Reverse (heating) or direct (cooling) action

Output 2: PID cooling control, cooling P band 1~255% of PB

ON-OFF: 0.1 - 100.0(F) hysteresis control (P band = 0)

P or PD: 0 - 100.0 % offset adjustment

PID:

Fuzzy logic modified Proportional band 0.1 ~ 900.0°F,

Integral time: 0 - 1000 Seconds,

Derivative time 0 - 360.0 seconds

Cycle Time: 0.1 - 100.0 seconds

Manual Control: Heat (MV1) and Cool (MV2)

Auto-tuning: (MV2) Cold start and warm start

Self-tuning: Select None and YES

Failure Mode: Auto-transfer to manual mode while sensor break or A-D converter damage

Sleep Mode: Enable or Disable

Ramping Control: 0 - 900.0°F/minute or 0 - 900.0°F/hour ramp rate

Power Limit: 0 - 100 % output 1 and output 2

Pump / Pressure Control: Sophisticated functions provided

Remote Set Point: Programmable range for voltage or current input

Differential Control: Control PV1-PV2 at set point

1.9.6.7 Profiler

Number of Profiles: 50

Number of Segments per Profile: 32

Note: Total Segments are limited to 1000 Segments

1.9.6.8 Digital Filter

Function: First Order

Time Constant: 0, 0.2, 0.5, 1, 2, 5, 10, 20, 30, 60 seconds programmable

1.9.7 COMM Module (IF232 and IF485) Specifications

Interface: RS-232 (IF232-one unit) or RS-485 or RS-422 (IF485- up to 247 units)

Protocol: Modbus Protocol RTU mode

Address: 1-247

Baud Rate: 9.6 ~ 115.2 Kbits/sec.

Data Length: 7 or 8 bits

Parity Bit: None, Even or Odd

Stop Bit: 1 or 2 bits

1.9.8 Standard Ethernet Communication

Protocol: Modbus TCP/IP, 10/100 Base T

Ports: AUI (Attachment Unit Interface) and RJ-45, Auto- detect capability

1.9.9 Real-time Clock

Item	Description
Make	Seiko Instruments
Model	MS621-fl11e
Rating	3V, 4mAH
Typical Life Time	10 Years
Buffer Period	6 Months
Type	Rechargeable
Accuracy	Maximum ± 2 Seconds/Day

1.9.9.1 Real time Clock accuracy vs Temperature inside of the housing

Temperature Inside Housing	Typical Error / Month
10°C ~ 40°C	18 Seconds
0°C or 50°C	52 Seconds
-10°C or 60°C	107 Seconds

1.9.10 Environmental & Physical Specifications

Operating Temperature: 0 ~ 50 °C

Storage Temperature: -30 ~ 70 °C

Humidity: 20 to 90% RH (non-condensing)

Maximum relative humidity 90% is for ambient temperature up to 38°C decreasing linearly to 50% relative humidity at 50°C

Altitude: 2000 M maximum

Insulation Resistance: 20 MΩ min. (at 500 VDC)

Dielectric Strength: 2300VAC, 50/60 Hz for 1 minute between power terminal and earth

Vibration Resistance: 10-55 Hz, 10m/ s² for 2 hours

Shock Resistance: 30m/ s² (3g) for operation, 20g for transportation

Operation Position: no inclined restriction

Dimensions: Panel Mount style: PPS-1000/PPS-2000: 144(W) x 144(H) x 193mm (D)

PPS-3000: 288(W) x 288(H) x 194mm (D)

Standard Panel Cut-out: PPS-1000/PPS-2000: 137 x 137mm

PPS-3000: 281 x 281mm

1.9.11 Approval Standards

Safety:

UL61010C-1, CSA C22.2 No. 24-93

CE: EN61010-1 (IEC1010-1) over voltage category II, Pollution degree 2

Protective Class:

IP 65 front panel for indoor use

IP 20 housing and terminals

EMC:

Emission: EN61326-1 (EN55022 class A, EN61000-3-2, EN61000-3-3)

Immunity: EN61326-1 (EN61000-4-2, EN61000-4-3, EN61000-4-4, EN61000-4-5, EN61000-4-6, EN61000-4-8, EN61000-4-11)

2. Installation and wiring

 Sometimes dangerous voltages capable of causing death are present in this instrument. Before doing installation or any troubleshooting procedures, the power to the equipment must be switched off and isolated. Units suspected of being faulty must be disconnected and removed to a properly equipped workshop for testing and repair. Component replacement and internal adjustments must be made by a qualified maintenance person only.

 To minimize the possibility of fire or shock hazards, do not expose this instrument to rain or excessive moisture.

 Do not use this instrument in areas under hazardous conditions such as excessive shock, vibration, dirt, moisture, corrosive gases or oil. The ambient temperature of the area should not exceed the maximum rating specified in the specification

 Remove stains from this equipment using a soft, dry cloth. Do not use harsh chemicals, volatile solvents such as thinner or strong detergents to clean the equipment in order to avoid deformation.

 If the equipment is used in a manner not specified by the manufacturer, the protection provided by the equipment may be impaired.

2.1 Unpacking

Upon receipt of the shipment, remove the recorder from the carton and inspect the unit for shipping damage. If any damage is found, contact your local representative immediately. Note the model number and serial number for future reference when corresponding with our service centre. The serial number (S/N) is labelled on the box and the housing of the recorder.

The recorder is designed for indoor use only, and is not intended for use in any hazardous area. It should be kept away from shock, vibration, and electromagnetic fields (such as variable frequency drives), motors and transformers. It is intended to operate under the following environmental conditions.

Environmental Parameter	Specification
Operating Temperature	0°C to 50°C
Humidity	20% to 90% RH(Non-condensing)
Altitude	2000 M Maximum
Pollution Degree Level II	IEC1010-1(EN61010-1)
Power	90 ~ 250 VAC, 50/60 Hz or 11-36VDC

2.2 Dimensions

2.2.1 Panel mounting style

2.2.1.1 PPS-1000

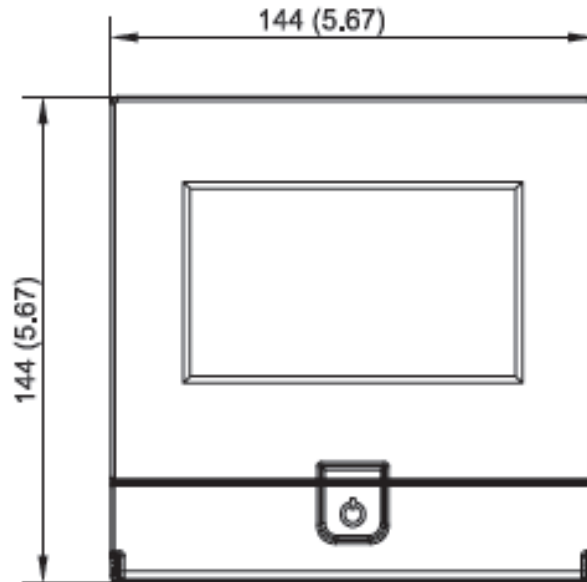

2-1 PPS-1000 Front Side

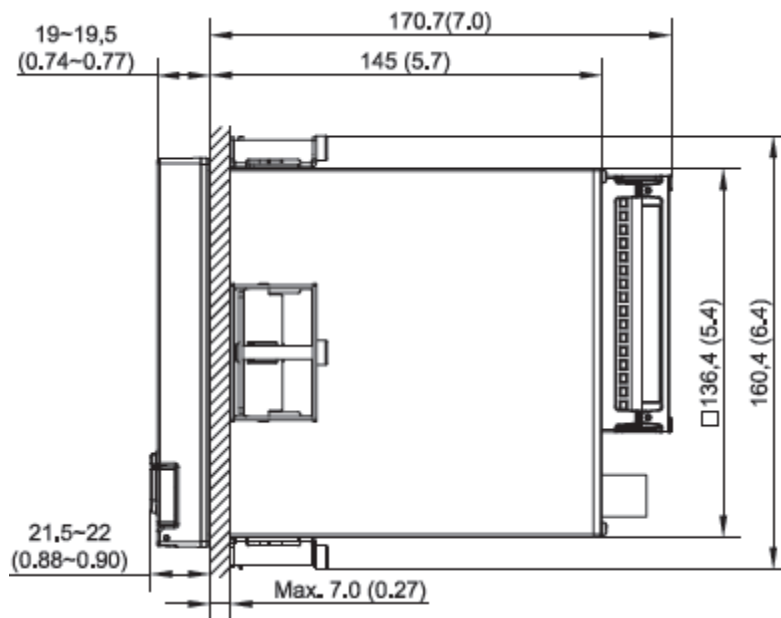

2-2 PPS-1000 Right Side

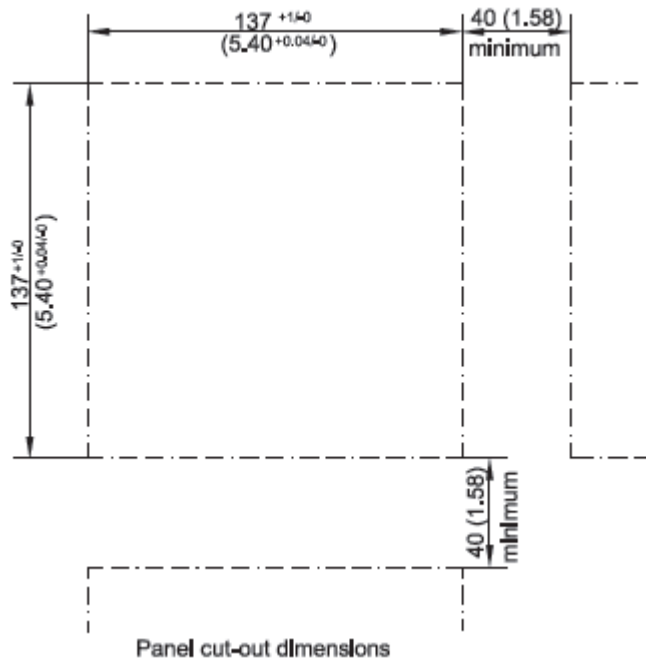

2-3 PPS-1000 Panel Cut-out Dimensions

2.2.1.2 PPS-2000

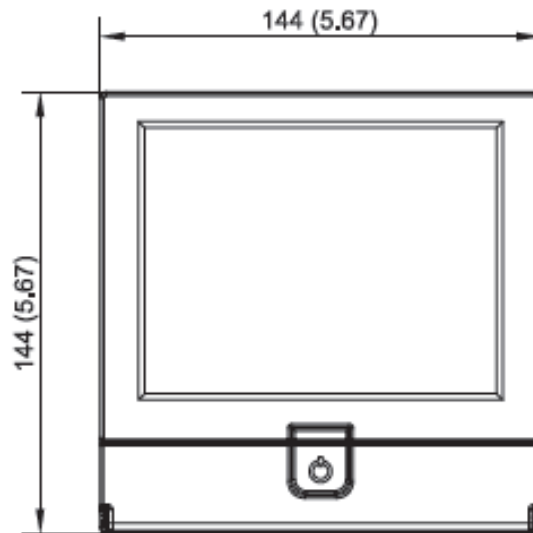

2-4 PPS-2000 Front Side

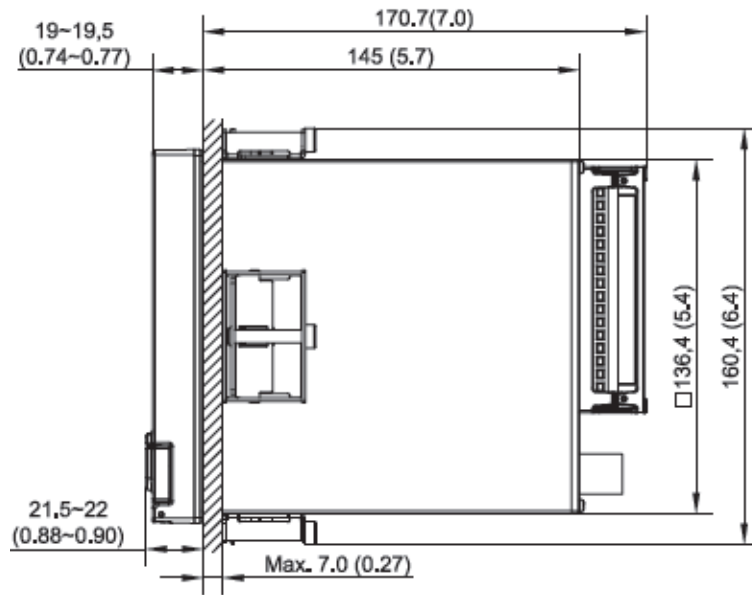

2-5 PPS-2000 Right Side

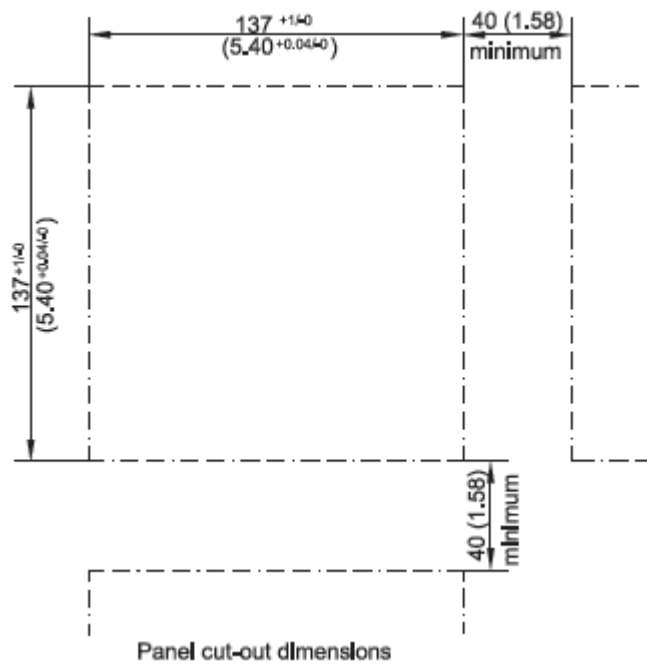

2-6 PPS-2000 Panel Cut-out Dimensions

2.2.1.3 PPS-3000

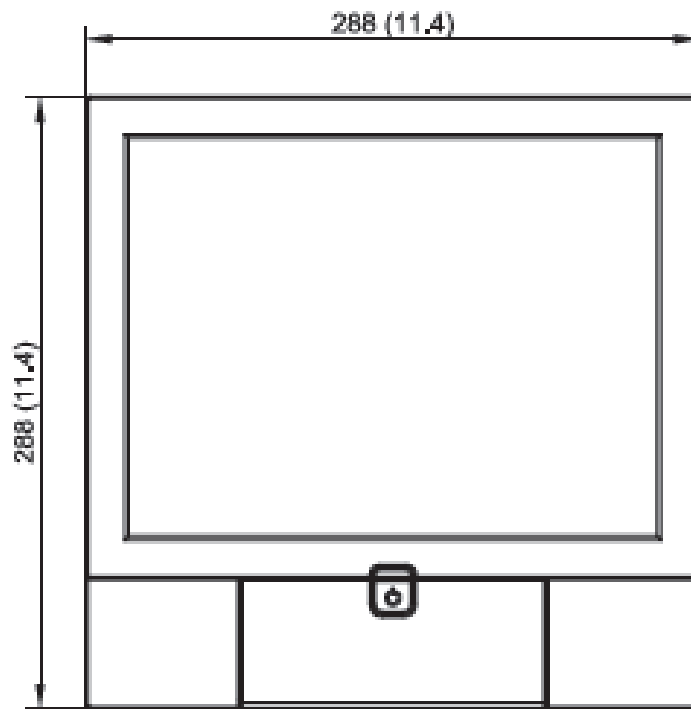

2-7 PPS-3000 Front Side

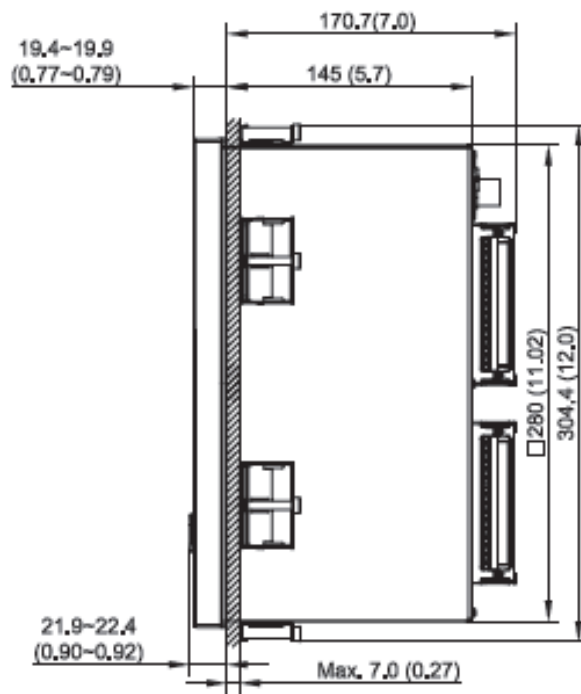

2-8 PPS-3000 Right Side

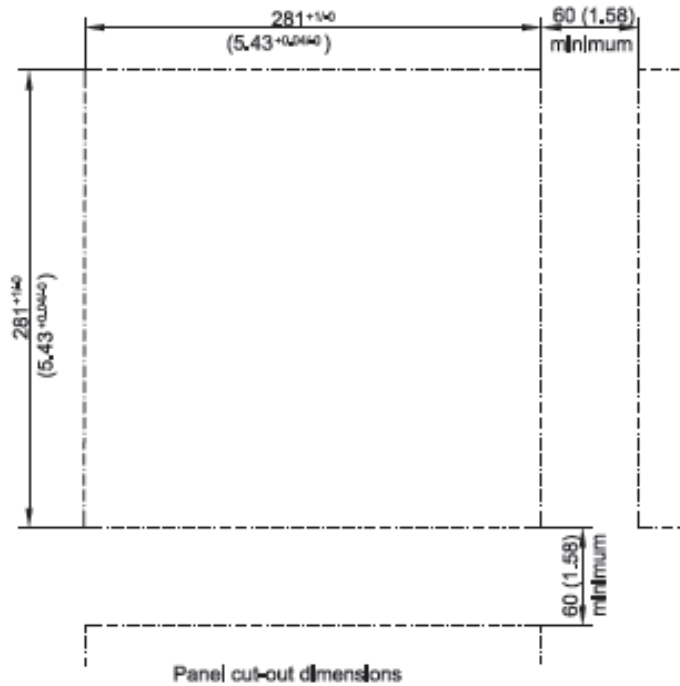

2-9 PPS-3000 Cut-out Dimensions

Note:

- ❖ Do not over tighten mounting clamp screws that could result in distortion of the case.
- ❖ There is no mounting angle restriction.
- ❖ The mounting torque used for 4 sides of the housing should be 2.0 KgF-cm and not more than 2.5 KgF-cm

2.2.2 Portable styles

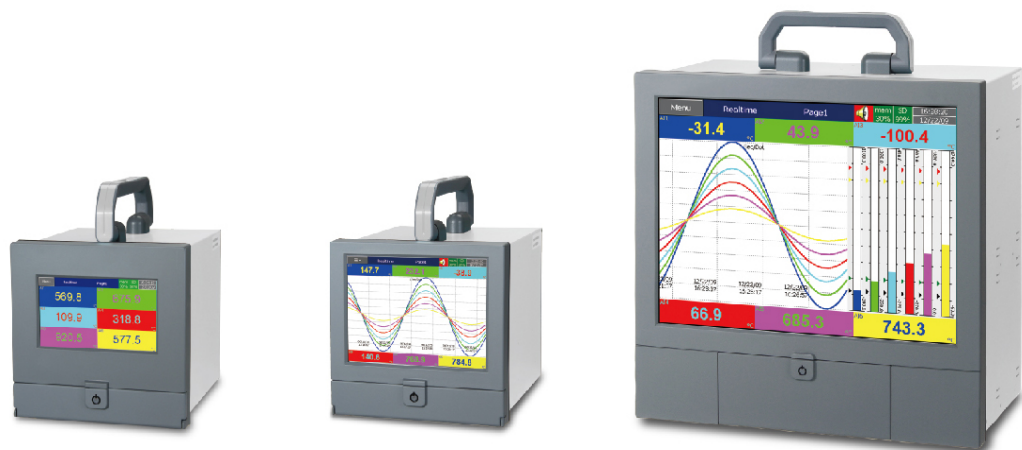

2.2.2.1 Bottom Side View of PPS-2000 & PPS-1000

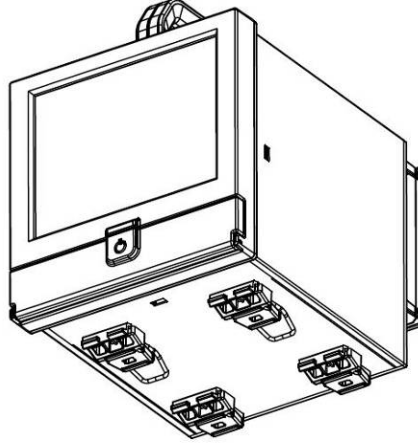

2-10 PPS-1000 & PPS-2000 Portable Type Bottom Side View

2.2.2.2 Front Side View of PPS-2000 & PPS-1000

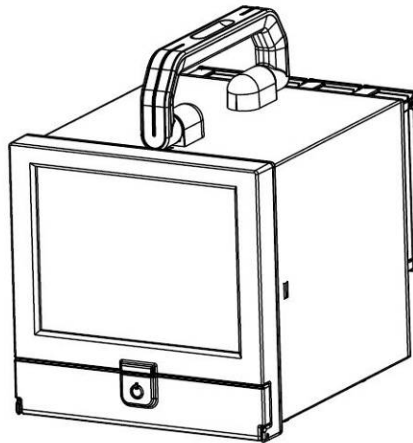

2-11 PPS-1000 & PPS-2000 Portable Type Front Side View

2.2.2.3 Bottom Side View of PPS-3000

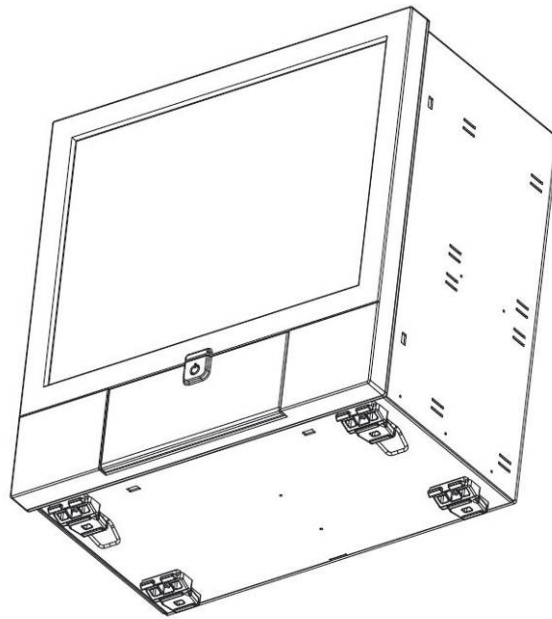

2-12 PPS-3000 Portable Type Bottom Side View

2.2.2.4 Front Side View of PPS-3000

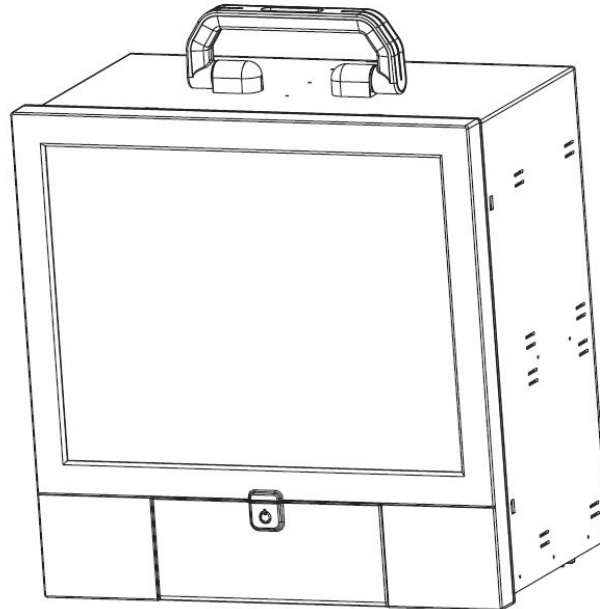

2-13 PPS-3000 Portable Type Front Side View

2.2.2.5 Bottom Stand Clips

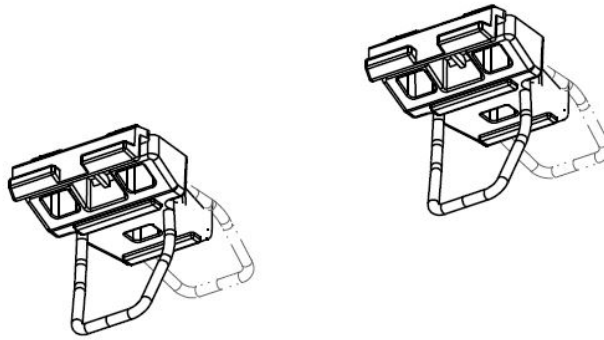

2-14 Portable Type Bottom Stand Clips

2.2.2.6 Top Holding Handle

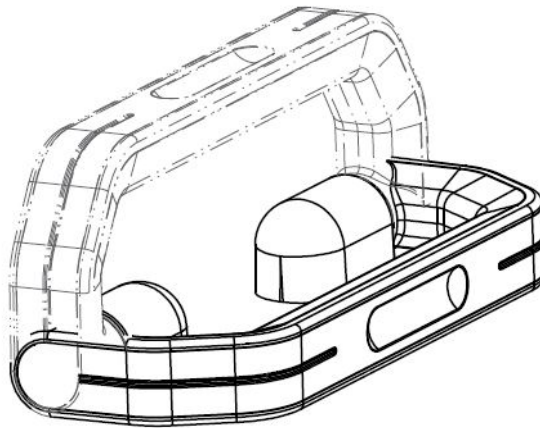

2-15 Portable Type Top Holding Handle

2.3 Input and Output Configuration

The Input and Output cards need to be inserted to the rear slots or removed from the rear slots at the Power OFF condition. Failure to do so may cause damage to the module or device or both. The Device will automatically detect the cards at Power ON, once it is inserted in to the rear slots.

2.3.1 Analog Input Card

PPS90001 and PPS90002 are analog input cards with 3 and 6 channels respectively. Each card includes universal inputs of TC (J, K, T, E, B, R, S, N, L, U, P, W5, W3, LR, A1, A2, A3, and M), RTD, mV, mA, V. The accepted input types and sensor range for analog input are listed in [Chapter 1.9](#). Plug the AI card into the rear slot then power on. The recorder will automatically detect the card and display the specific input type and its location in a specific slot in **System Information** mode while doing the configuration.

The configuration Menu can be reached by pressing Menu and then pressing more and then pressing Config key. It will display a tree type configuration layout for easy user configuration. By using Up/Down Key and Enter Key, AI configuration window can be reached. In this window the user can configure the AI parameters. The user can select the desired input type and other parameters for analog input in this window.

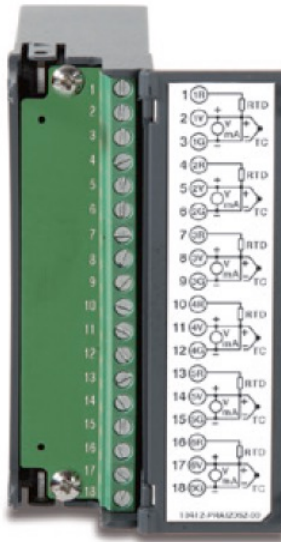

2.3.2 Relay Output card

The relay output card PPS90003 includes 6 relays rated 5 Amp/240 VAC each. Plug the card into a rear slot and power on the recorder. The recorder will automatically detect the card and display the output type and its location in a specific slot in System Info mode while doing the configuration.

The configuration Menu can be reached by pressing Menu and then pressing more and then pressing Config key. It will display a tree type configuration layout for easy user configuration. By using Up/Down Key and Enter Key, DO configuration window can be reached. In this window the user can configure the DO parameters. The user can select the desired output type and other parameters for Relay output in this window. The item "Reverse" is to reverse the output status.

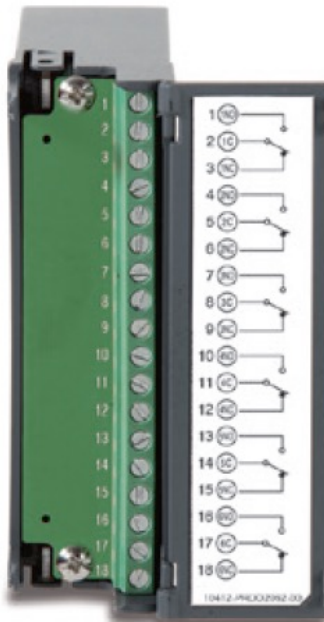

2.3.3 Digital Input card

The PPS90004 card includes 6 channels of event inputs. As above, plug the card into rear slot and power on the recorder. The recorder will automatically detect it, and then display the input type and its location in a specific slot in **System Information** mode while doing the configuration.

The configuration Menu can be reached by pressing Menu and then pressing more and then pressing Config key. It will display a tree type configuration layout for easy user configuration. By using Up/Down Key and Enter Key, DI configuration window can be reached. In this window the user can configure the DI parameters. The user can select the desired input type and other parameters for digital input in this window. The item "Type" is for the user to decide if this channel will have a logic level or Pulse Counter input. If you select Pulse Counter, the item "Frequency" will appear for you to select input frequency (100Hz). The item "Events" can be added to do further control.

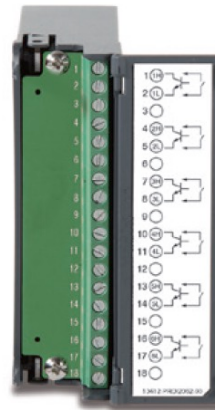

2.3.4 Combination Digital Input and Output card

The PPS90005 card includes 3 relays rated 5 Amp/240VAC each and 3 Channels of Digital Inputs. As above, plug the card into rear slot and power on the recorder. The recorder will automatically detect it, and then display the input type and the output type on its location in a specific slot in **System Information** mode while doing the configuration. The first 3 channels are for relays (Terminal 1 to 9) and last 3 channels are for Digital inputs (Terminals 10 to 18). The setup is similar to relay output card and digital input card.

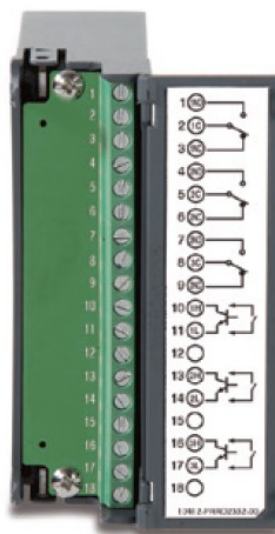

2.3.5 Analog output cards

The PPS90006 card is a 6-channel analog output card. They are used to retransmit process values to other devices like meters, controllers, etc. The configuration Menu can be reached by pressing Menu and then pressing more and then pressing Config key. It will display a tree type configuration layout for easy user configuration. By using Up/Down Key and Enter Key, AO configuration window can be reached. In this window the user can configure the AO parameters. The user can select the desired output type and other parameters for analog output in this window.

Note: There is dip switch on the card to select the current or voltage output for each channel.



2.3.6 PID Process Control Module

The PCSPCM is a single loop PID Control Module which consists of Universal Input. The Module output can be configured by using the configuration Menu. The configuration Menu can be reached by pressing Menu and then pressing more and then pressing Config key. It will display a tree type configuration layout for easy user configuration. By using Up/Down Key and Enter Key, PID Controller and Profile configuration window can be reached. In this window the user can configure the Controller parameters and profiles of PID Control Module. The user can select the desired output type and other parameters for analog output in this window.

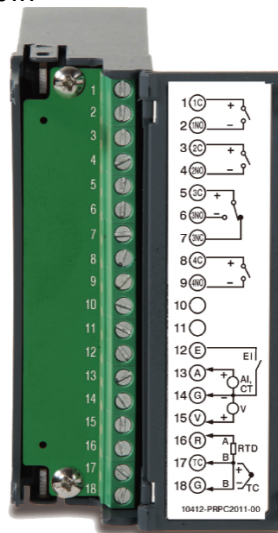

Note:

- ❖ The IO Modules should not be removed or Inserted to the device when the Power is ON. This should be carried out in the Power OFF Condition only.
- ❖ For removing the IO Modules, First remove the metal screws then remove the plastic screws, after that press the lock on the top and bottom of the Card and pull to remove it. Failing to do so will damage the IO Card. Please follow the Recorder user manual for more information.
- ❖ The Maximum Torque for the metal screw is 3Kg-cm (2.6in-lb) and the Maximum Torque for the plastic screw is 0.8Kgf-cm (.7in-lb).
- ❖ Calibration should be carried out by a qualified Engineer with qualified equipment only.
- ❖ Thermocouple inputs requires 1 hour initial warm up time during initial setup.
- ❖ For some industries who prefer circular chart displays, PPS-3000 can offer this Unique feature and set the display speed for each page/circle in 30 minutes, 1, 2, 4, 8, 12 hours, 1, 2 days, or 1, 2, 4 weeks.

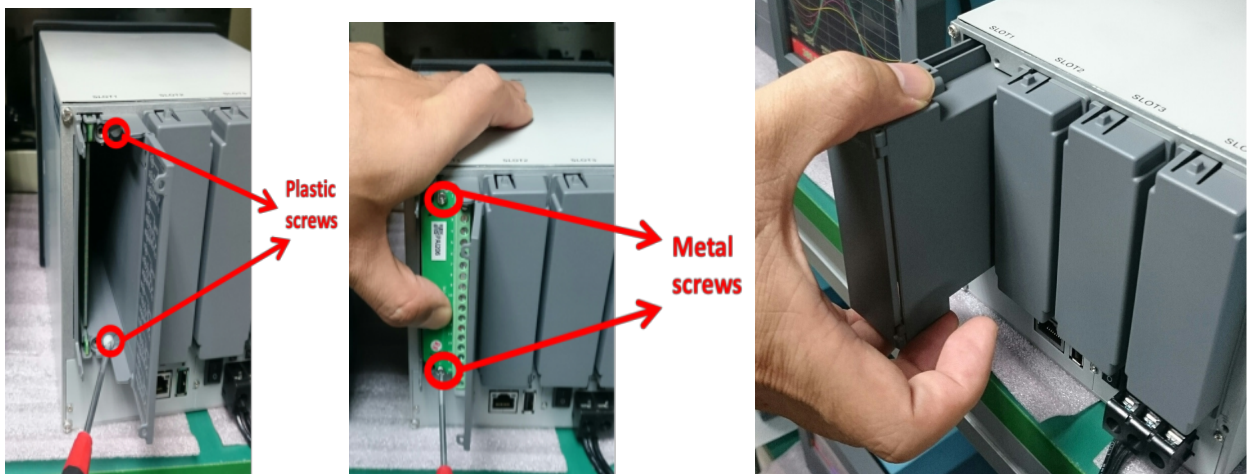

2.4 Wiring

2.4.1 Wiring

⚠ Care must ensure that the rating specified exceeded.

⚠ For the panel-mount version, it is recommended that near an external fuse or an external switch rated at 2A/250 VAC should be used.

⚠ Beware not to over tighten the terminals screws. The torque should not exceed 0.4 N-m (3.6 Lb-in or 4.0 Kg F-cm).

⚠ With the exception of the thermocouple wires, all wires should be stranded copper conductor with maximum gauge of 18 AWG.

⚠ Connect a grounding conductor with 1.6mm diameter minimum to provide protective grounding prior to turning on the equipment.

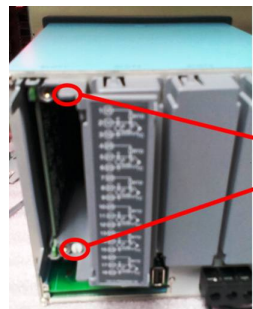

Plastic screws

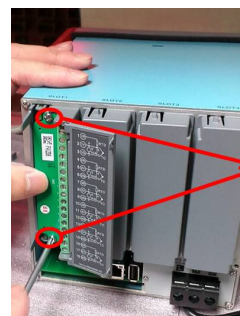

Metal Screws

Precautions

be taken to maximum voltage on the label is not

panel-mount

2.4.2 Analog Input Wiring

2.4.2.1 PPS90001 6 channel analog input wiring

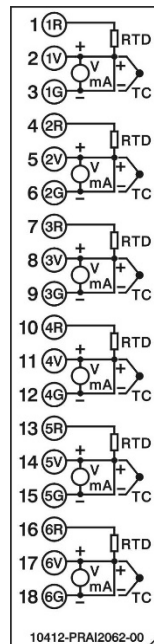

PPS90002 3 channel analog input wiring

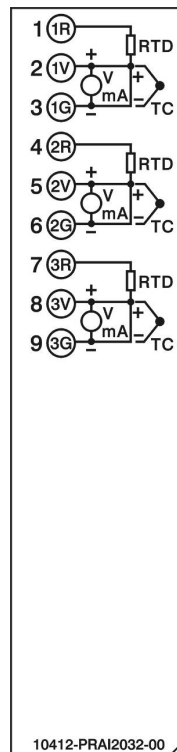

2.4.3 Relay Output Wiring

2.4.3.1 PPS90003 6 channel relay output wiring

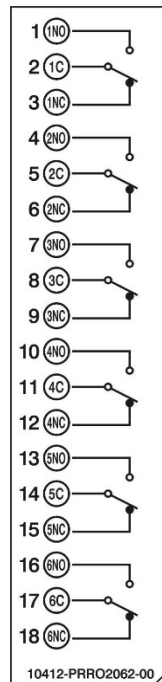

2.4.4 Digital Input Wiring

2.4.4.1 PPS90004 6 channel digital input wiring

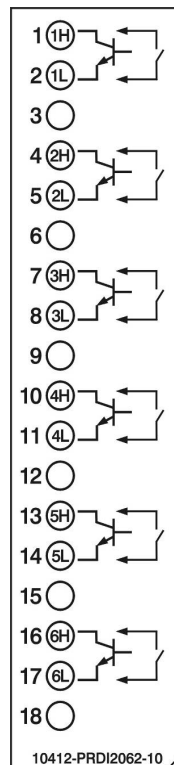

2.4.5 Combination Relay Output and Digital Input Wiring

2.4.5.1 PPS90005 3 Output and 3 channel Digital Input Wiring

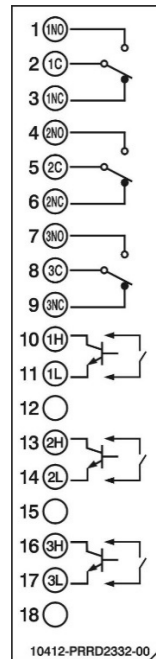

2.4.6 Analog Output Wiring

2.4.6.1 PPS90006 6 channel analog output wiring

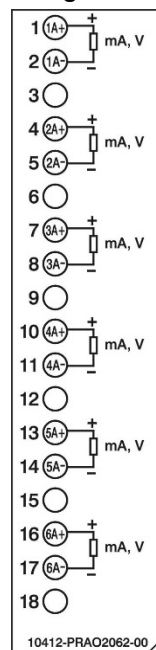

2.4.7 PID Process Control Card Wiring

2.4.7.1 PPSPCM

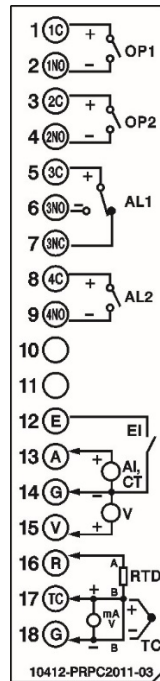

2.4.8 RS-232, RS-422, and RS-485 wiring

2.4.8.1 RS232 Wiring

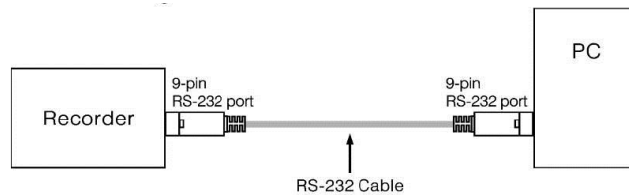

Configuration of The RS-232 Cable

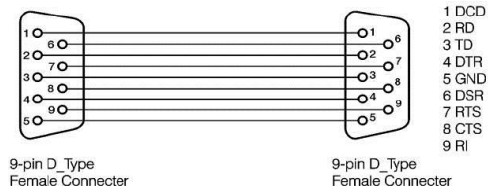

2.4.8.2 RS422 Wiring

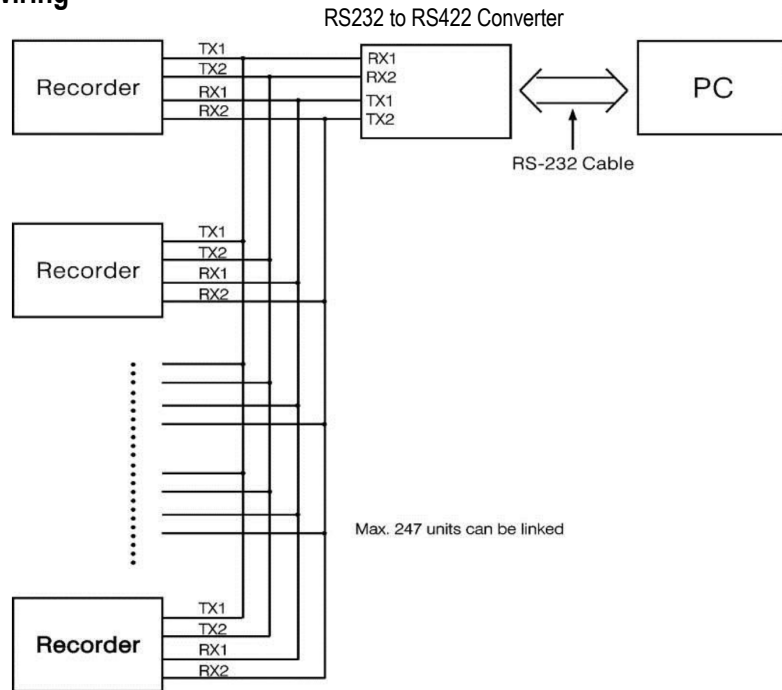

2.4.8.3 RS485 Wiring

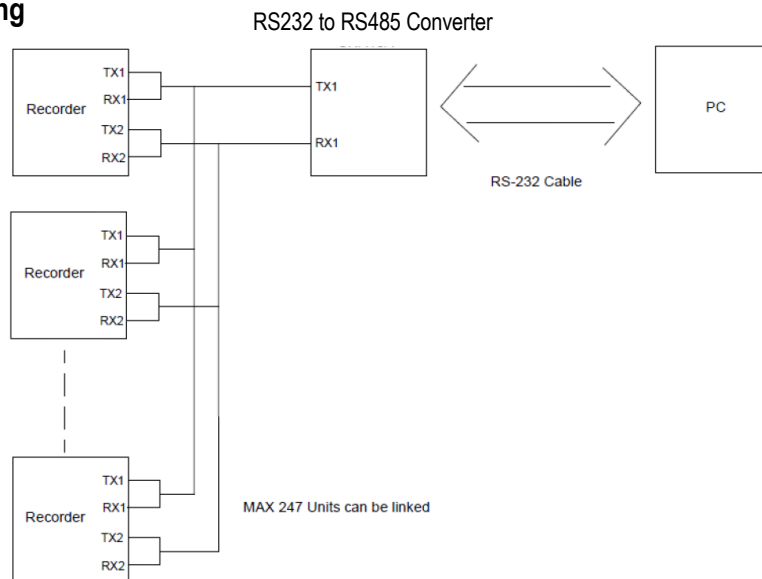

2.5 External Memory Card

There are two types of external storage for the User to use in the recorder. One is the SD card and other is USB memory. There are two slots for inserting USB memory, one in the front and other on the rear side of the recorder. If bigger capacity USB memory is required, the user may buy it locally. The SD card slot is in the front side. Please see the below figures for more information.

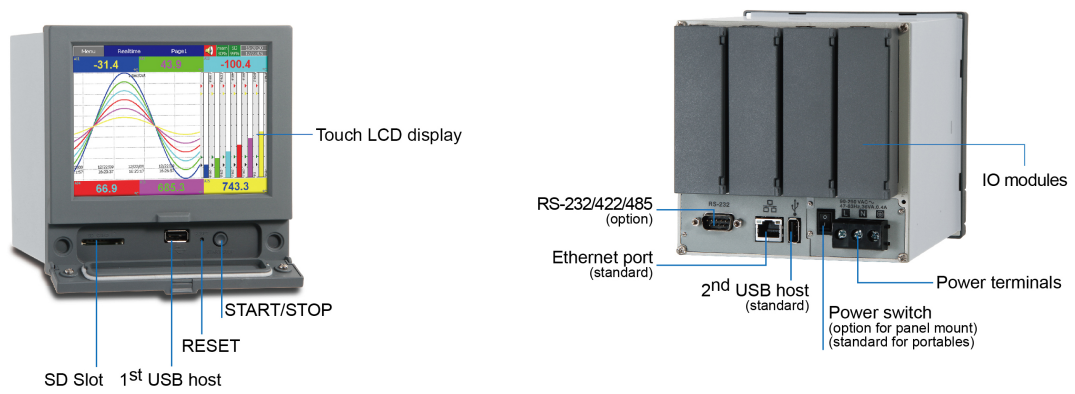

Note

- ❖ The maximum capacity of external memory supported by recorder is 32GB. The external memory must be formatted to FAT or FAT32.
- ❖ To read measured data and events on USB memory and SD card Memory, it is necessary to install either the free basic software or the Extensive Data Acquisition software on PC first.

3. BASIC FUNCTIONS OF RECORDERS

3.1 Configuration

The configuration of the recorder follows a tree type layout. This makes it easy for the users to go through the different sub menus easily and do not miss any configuration.

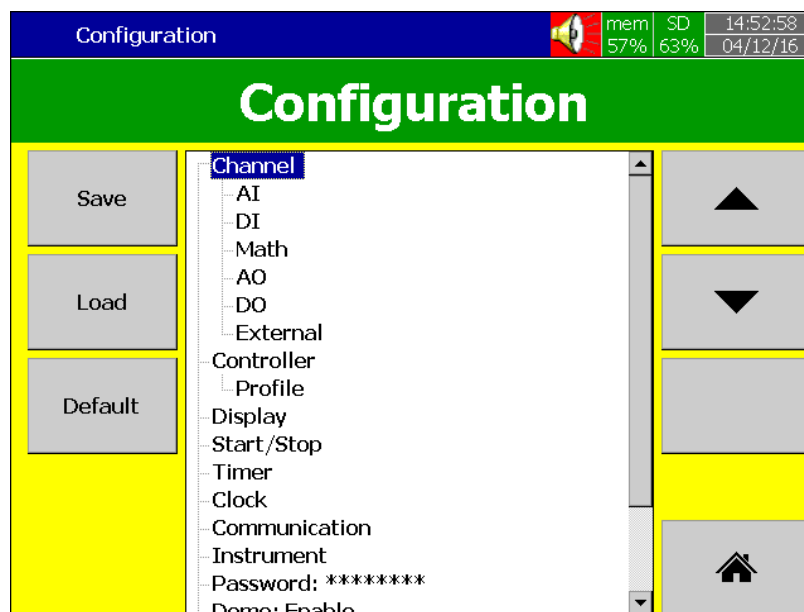

3.2 Firmware

The PPS series recorder has 4 different versions of firmware for the user to select as per the application requirement.

1. Standard Firmware
2. Plus 1 Firmware
3. Plus 2 Firmware
4. Plus 3 Firmware

3.2.1 Standard Firmware

The standard version of firmware have Input and output configuration, Math functions (Counter, Totalizer),PID Controller function with PID Process control card.This firmware does not include External channels, Custom Edited Display, Batch, or FDA 21 CFR part11 functions.

3.2.2 Plus 1 Firmware

The plus 1 firmware have external channel, Batch, FDA 21CFR Part 11 functions along with the functions available in standard version firmware. This firmware does not include custom display function.

3.2.3 Plus 2 Firmware

The plus 2 firmware version have custom display function similar to HMI along with the functions available in standard version firmware. This firmware does not include external channel, Batch, FDA 21CFR part11 functions.

3.2.4 Plus 3 Firmware

The plus 3 firmware have all the functions of standard, plus1, plus 2 version firmware.

3.3 Pulse input through Digital input

The recorder will support pulse input up to 100Hz via digital input. The digital input can be configured as pulse counter to count the no of pulses.

3.4 PID control with Ramp & Soak Profile function

The recorder has the option to use PID control function by using PPSPCM PID process control card. The PID Control Module includes Ramp & Dwell function. It is useful to control the process with varying set point time to time. There are 50 different Profiles can be configured with 32 Segments/Profile with the limit of 1000 Segments totally.

3.5 On Field Calibration

The Device allows the user to do on field calibration for the device. No need to send the device to factory for Calibration.

Note: The calibration must be carried out by a skilled person with proper instruments.

3.6 Communication with Third Party Interfaces

The Recorder has the flexibility to communicate with Third party Interfaces via protocols such as Modbus TCP/IP or Modbus RTU as either a Modbus Master or Modbus Slave. The detailed configuration and related information are available in [Chapter 5 Configuration, and Section 5.9.](#)

3.7 Web Server

The Recorder Trend and Digital data can be viewed in any place in the world if we have Web Server connectivity. For this the Recorder should be connected to Internet with a fixed IP address provided by the Internet Service provider.

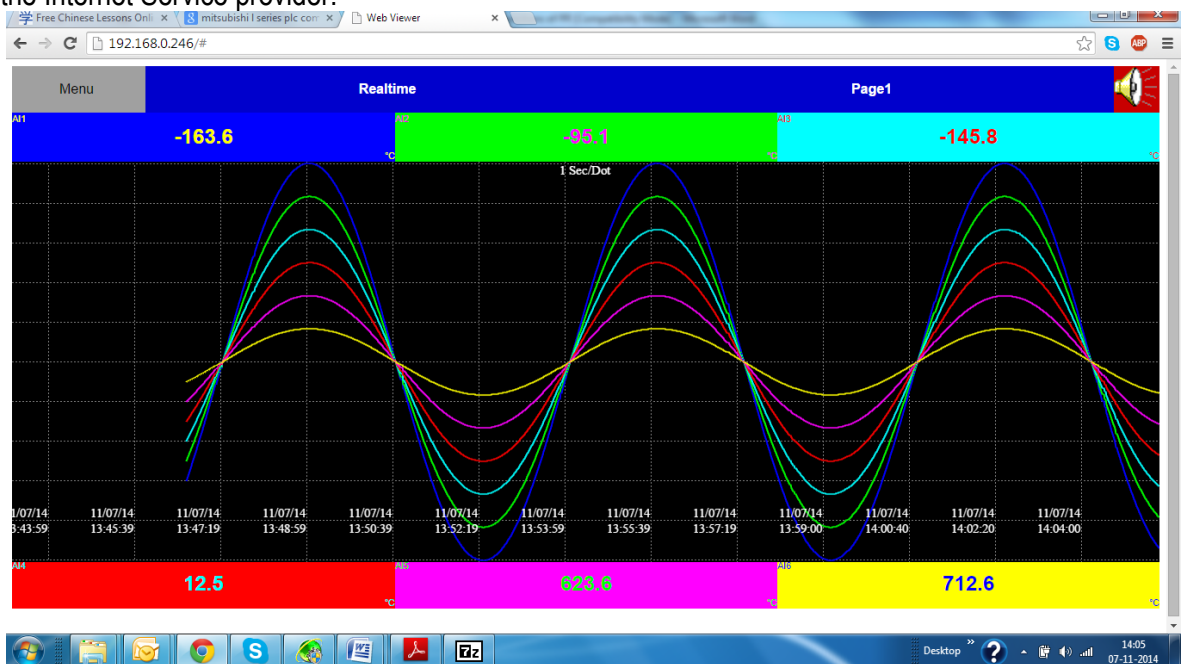

3.8 Email

All Important system events and alarms can be sent as an email. The detailed configuration and related information are available in [Chapter 5, Configuration, and Section 5.9.5.](#)

3.9 Handwriting Messages on Historical Trend Screens

Handwriting Messages on Historical trend screen is a useful feature for the user to highlight important events. The User can write handwritten messages using a stylus on Historical Trend screens. This is shown in the below picture.

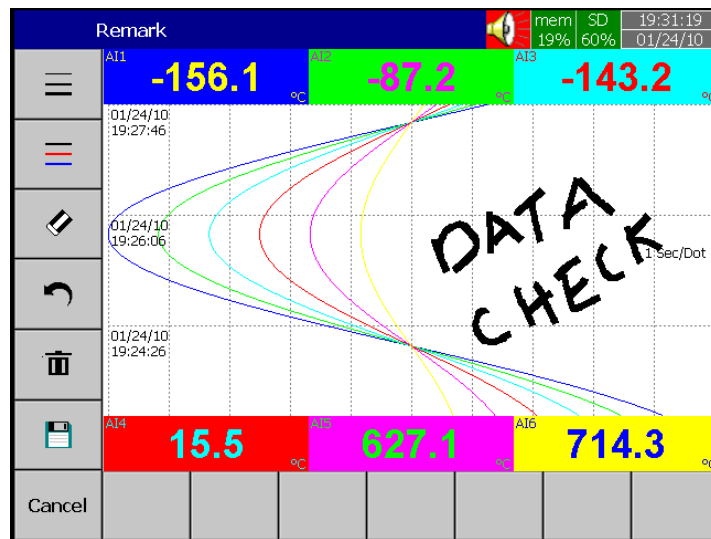

3.10 Custom Display Screen

In plus 2 and plus 3 versions of firmware, the recorder allows the user to download the custom screens linked with Analog and Digital Tags from the custom display editor software Panel Studio. The custom display screens are called custom page in the recorder. The software used to create custom screen called as custom screen editor (Panel studio).

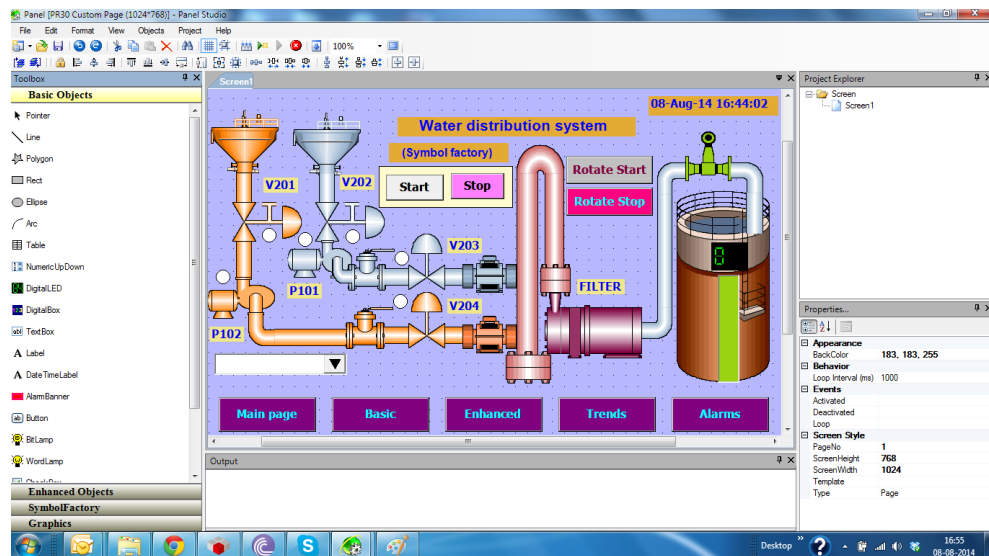

3.11 Log Speed Flexibility

The recorder has various log speed flexibility for the user to select as per their requirement. The available log speeds are 100ms/Dot, 1 Sec/Dot, 2 Sec/Dot, 5 Sec/Dot, 10 Sec/Dot, 15 Sec/Dot, 20 Sec/Dot, 30 Sec/ Dot, 1 Min/Dot, 2 Min/Dot, 5 Min/Dot, 10 Min/Dot, 15 Min / Dot, 1 Hour/Dot, 2 Hour/Dot. The User has a lot of flexibility in logging speeds to select as per the application requirement.

3.12 System Clock Synchronization via Internet

The Recorder System clock can be synchronized via internet and Summer Saving Time can be defined. The detailed configuration and related information are available in [Chapter 5, Configuration, and Section 5.8.](#)

3.13 Increased Security

The security mode can be configured as normal or CFR-21. For normal, there is only one password can be defined for configuration. For CFR-21, there are 9 levels of password with 30 users can be defined for different functions. The detailed configuration and related information are available in [Chapter 5, Configuration, and Section 5.11.](#)

3.14 Auto Output to Printer

The Historical data can be directly printed automatically by a printer or can be saved as a PDF file using PDF printer. The detailed configuration and related information are available in [Chapter 5, Configuration, and Section 5.13.](#)

3.15 External Channels

Besides on-board AI and DI inputs, the recorder can accept inputs through Modbus communication. The PPS-1000, PPS-2000, and PPS-3000 can have a maximum of up to 24, 48 and 96 channels respectively. The detailed configuration and related information are available in [Chapter 5, Configuration, and Section 5.9.](#)

3.16 Batch

Using this function, the recorded data can be stored in batches. This makes it easy for the user to analyse the historical data.

3.17 FDA 21 CFR PART 11

This feature is meant to comply with U.S. Food and Drug Administration with human health concern. When this feature is enabled, the recorded data cannot be manipulated.

3.18 Circular Chart

PPS-3000 has a unique feature to display the trend in circular chart mode. The recorder has various log speed flexibility for the user to select as per their requirement. The available log speeds are 100ms/Dot, 1 Sec/Dot, 2 Sec/Dot, 5 Sec/Dot, 10 Sec/Dot, 15 Sec/Dot, 20 Sec/ Dot, 1 Min/Dot, 2 Min/Dot, 5 Min/Dot, 10 Min/Dot, 15 Min / Dot, 10 Min/Page, 30 Min/Page, 1 Hour/Page, 2 Hour/Page, 4 Hour/Page, 8 Hour/Page, 12 Hour/Page, 1 Day/Page, 2 Day/Page, 1 Week/Page, 2 Week/Page, 4 Week/Page, 1 Hour/Dot, 2 Hour/Dot. The User has a lot of flexibility in logging speeds to select as per the application requirement.

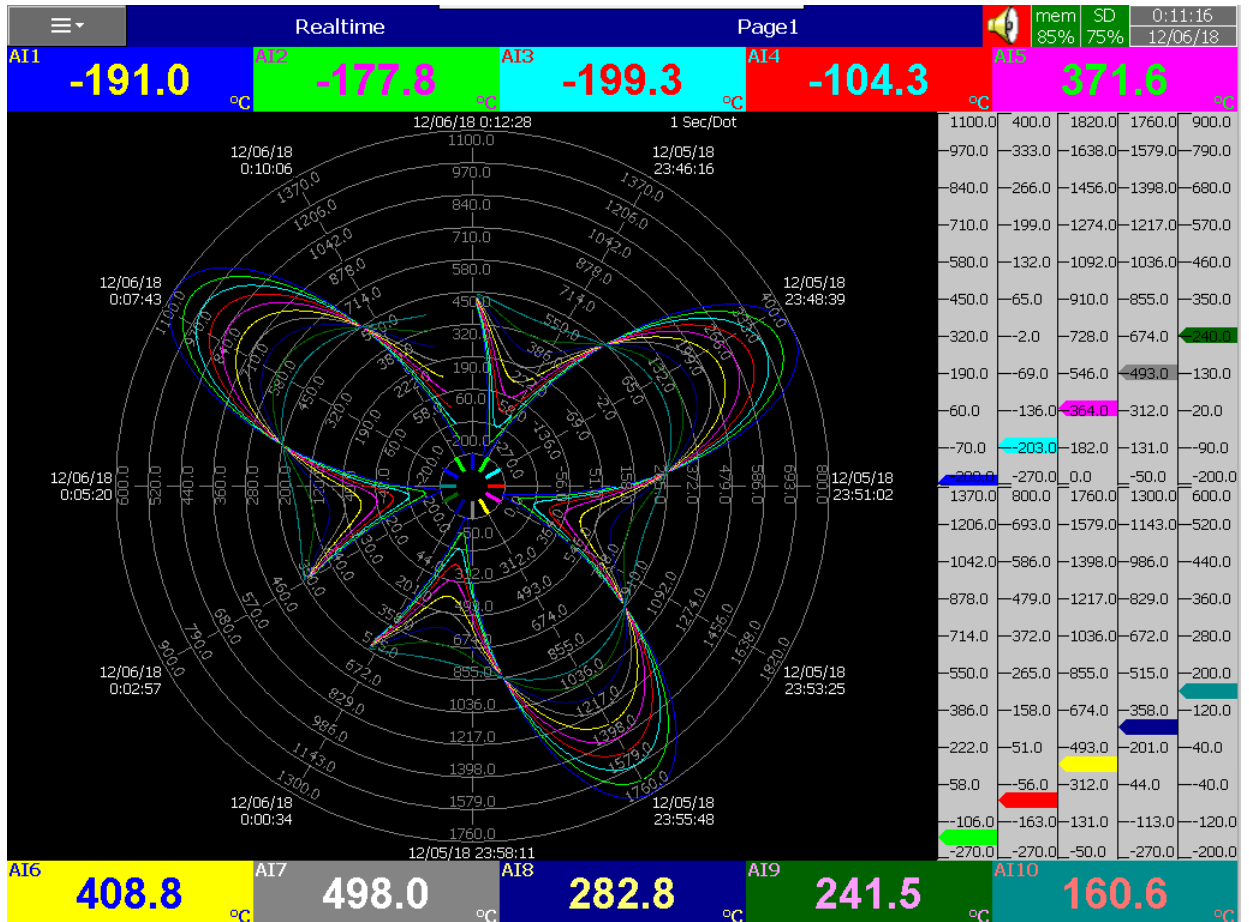

3.19 Multilingual Languages

The recorder provides multiple language options for the user to select as per their convenience. The available languages are Brazil Portuguese, Chinese (Simplified, Traditional), Czech, Danish, Dutch, English, French, German, Greek, Italian, Japanese, Korean, Polish, Portuguese, Russian, Spanish, Swedish, Thai, Turkish. Other Languages negotiable.

3.20 USB Barcode Reader, Keyboard and Mouse Connectivity

The recorder supports the data entry through USB Keyboard, Mouse and Barcode reader for the configuration.

4. GETTING STARTED

The recorder has a TFT touch screen display capable of complex graphical representation, internal memory and SD card slot or USB drive slot for data storage. The unit is easily programmable, and the average user will probably never need to use most of the features or functions available in the recorder. This chapter will give the user a brief system overview and guide the first-time user in a simplified setup which will enable you to begin recording with the least amount of effort.

4.1 Screen Navigation

The recorder has a TFT touch screen which shows graphics. The screen that also acts as a touch keypad. The user has only to lightly touch the screen area to operate. If the Beep volume is enabled then the unit will provide a short audible beep, each time the screen is touched. The default display of the recorder which shows after power on is as below.

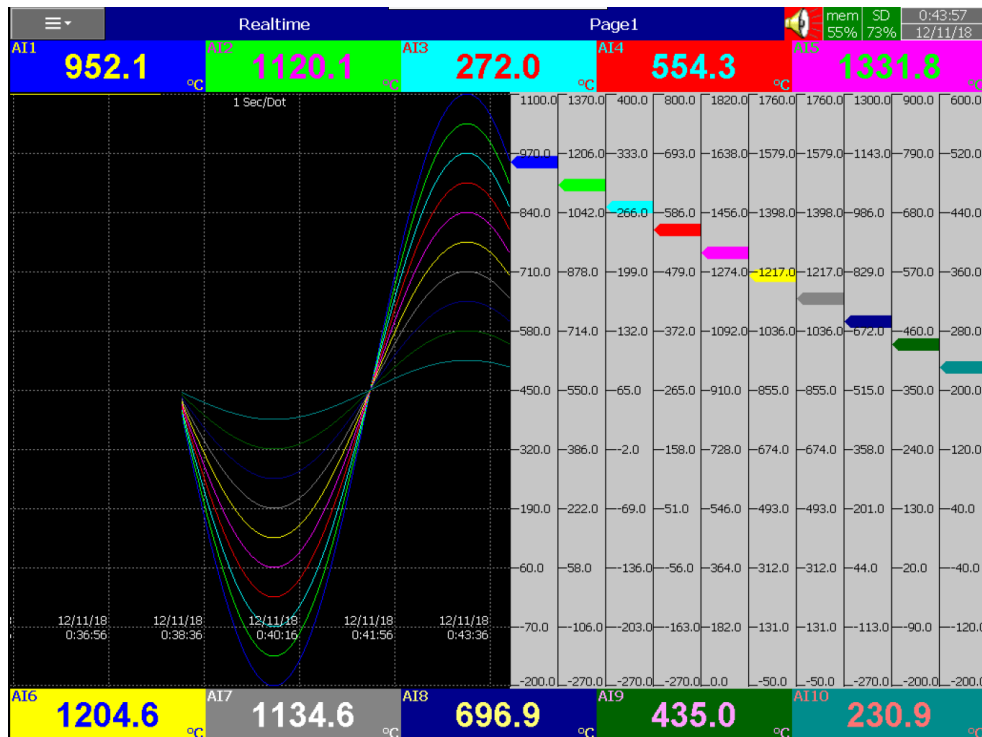

The screen is divided into two distinct areas such as Title Bar, across the top of the screen and the Graphics Area below the Title bar.

4.1.1 Title Bar

The Status Bar consists of Menu key , Page Type, Page Name, Alarm Status, Internal memory status, External memory status, Date and Time.

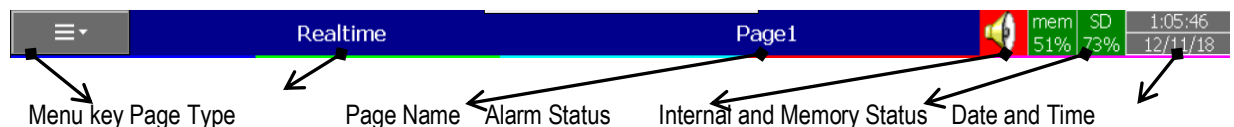

4.1.1.1 Menu key

The menu key will allow the user to access the menus available in the recorder. When the user press the menu key, , the available menus are displayed.

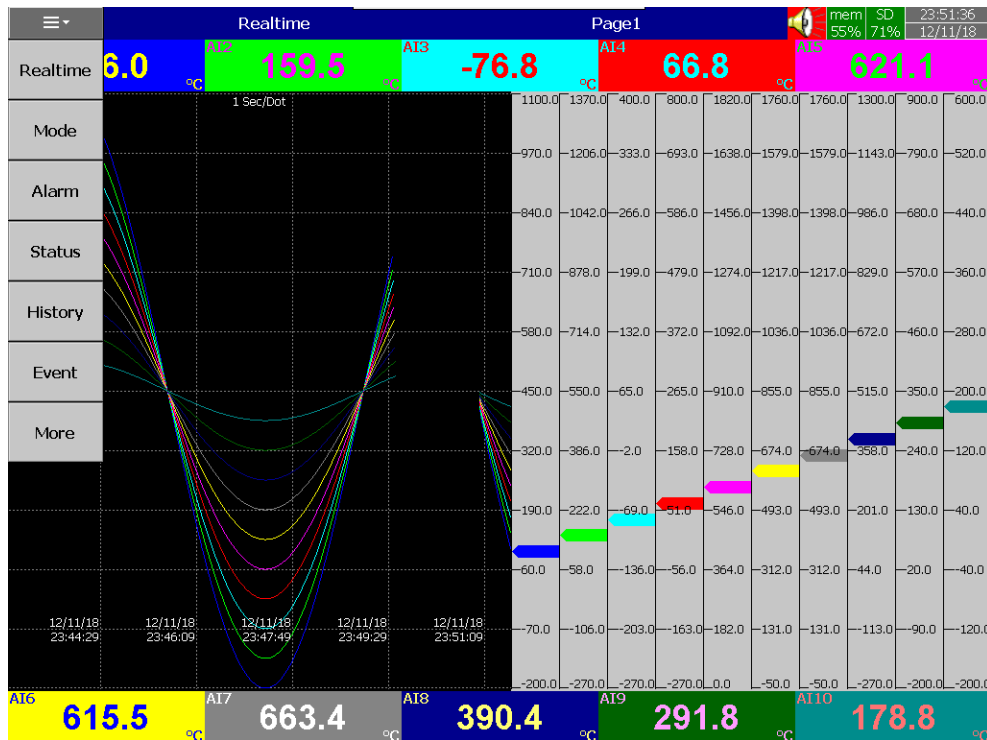

4.1.1.1.1 Real Time

Real time menu will allow the user to access the real time display of the configured display pages, Overview display, PID Control card display page and custom screen display page.

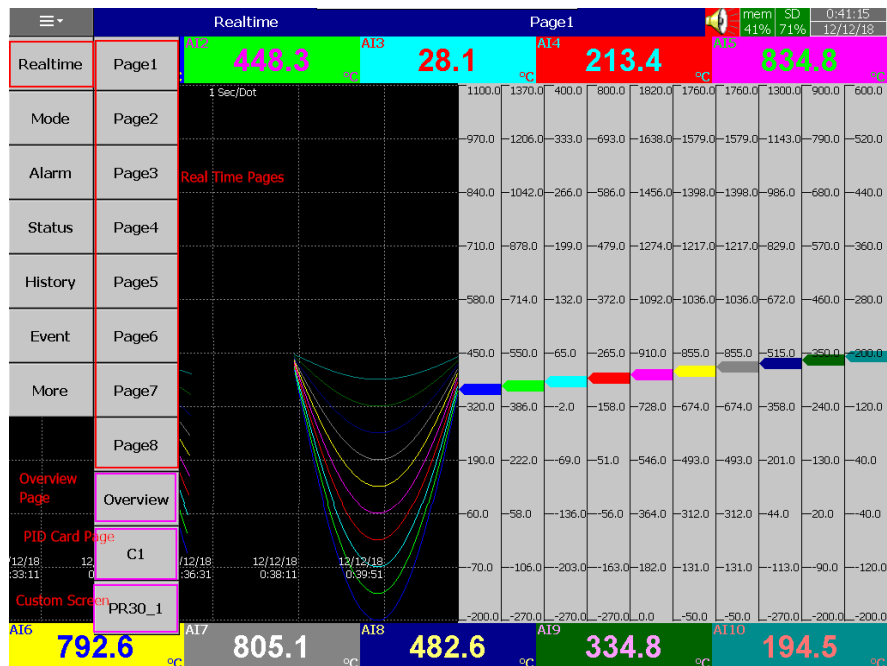

4.1.1.1.2 Mode

Mode Menu will allow the user change the graphical display mode. The available display modes are Trend, Bar Graph, Digital, Mix Mode, Individual Mode and Circular Mode (only for PPS-3000).

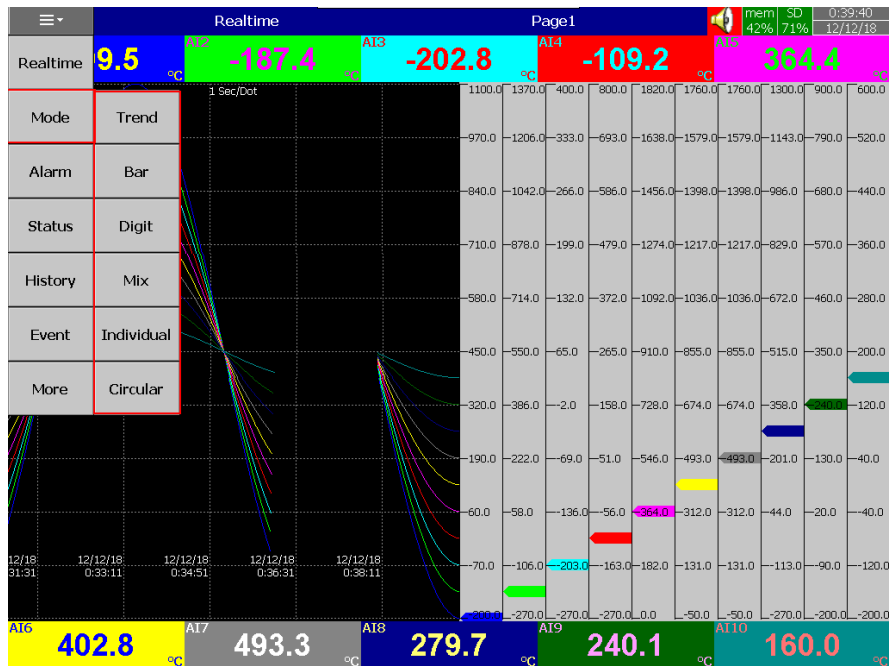





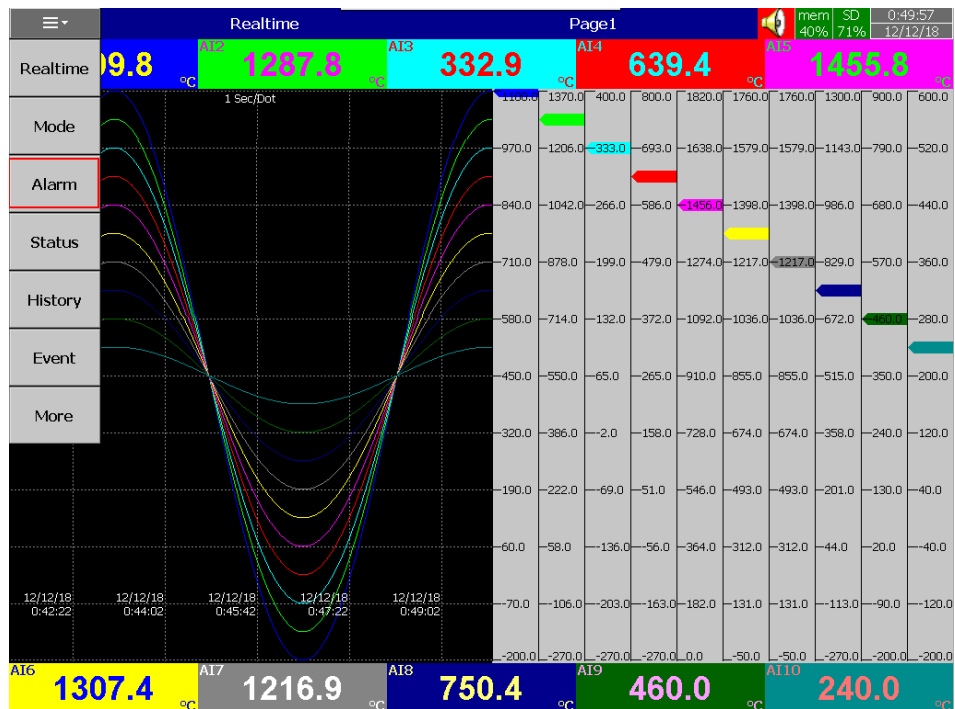

4.1.1.1.3 Alarm

Alarm menu will allow the user to access the real time alarm page. In this page the user can view the real time alarms and acknowledge the alarms.



No.	Active Time	Acked	Type	Name	Value
1	12/12/18 0:38:14		HiAlarm	AI11	1851.71
2	12/12/18 0:38:14		HiAlarm	AI11	1851.71
3	12/12/18 0:38:14		HiAlarm	AI12	2168.41
4	12/12/18 0:38:14		HiAlarm	AI12	2168.41
5	12/12/18 0:38:14		HiAlarm	AI13	565.31
6	12/12/18 0:38:14		HiAlarm	AI14	1093.75
7	12/12/18 0:38:14		LoAlarm	AI31	-301.01
8	12/12/18 0:38:14		LoAlarm	AI31	-301.01
9	12/12/18 0:38:14		LoAlarm	AI32	-275.76
10	12/12/18 0:38:14		LoAlarm	AI32	-275.76
11	12/12/18 0:38:14		LoAlarm	AI33	-322.27
12	12/12/18 0:38:14		LoAlarm	AI33	-322.27
13	12/12/18 0:38:14		LoAlarm	AI34	-149.55
14	12/12/18 0:38:31		LoAlarm	AI21	-12.00
15	12/12/18 0:38:31		HiAlarm	AI26	80.00
16	12/12/18 0:38:39		LoAlarm	AI21	-30.00
17	12/12/18 0:38:39		LoAlarm	AI22	10.40
18	12/12/18 0:38:39		HiAlarm	AI26	87.50
19	12/12/18 0:38:39		HiAlarm	AI27	80.00
20	12/12/18 0:38:42		LoAlarm	AI1	59.73
21	12/12/18 0:38:42		LoAlarm	AI41	9.78
22	12/12/18 0:38:48		LoAlarm	AI2	57.62
23	12/12/18 0:38:48		LoAlarm	AI42	49.56
24	12/12/18 0:38:48		LoAlarm	AI22	-22.09
25	12/12/18 0:38:48		HiAlarm	AI27	87.52
26	12/12/18 0:38:51		LoAlarm	AI23	20.00
27	12/12/18 0:38:51		HiAlarm	AI28	80.00
28	12/12/18 0:38:55		LoAlarm	AI1	-37.57
29	12/12/18 0:38:55		LoAlarm	AI3	-136.03
30	12/12/18 0:38:55		LoAlarm	AI41	-48.81
31	12/12/18 0:38:55		LoAlarm	AI43	9.95
32	12/12/18 0:39:04		LoAlarm	AI2	-65.95
33	12/12/18 0:39:04		LoAlarm	AI42	-92.38
34	12/12/18 0:39:07		LoAlarm	AI4	-56.14
35	12/12/18 0:39:07		LoAlarm	AI44	49.75
36	12/12/18 0:39:19		LoAlarm	AI3	-186.29



The user can acknowledge the alarm by pressing the ACK key. The user can navigate

the alarm display by using the scroll keys    . The user can go back to Home screen by pressing the Home  key. The user can access other menus by pressing the menu  key.

4.1.1.1.4 Status

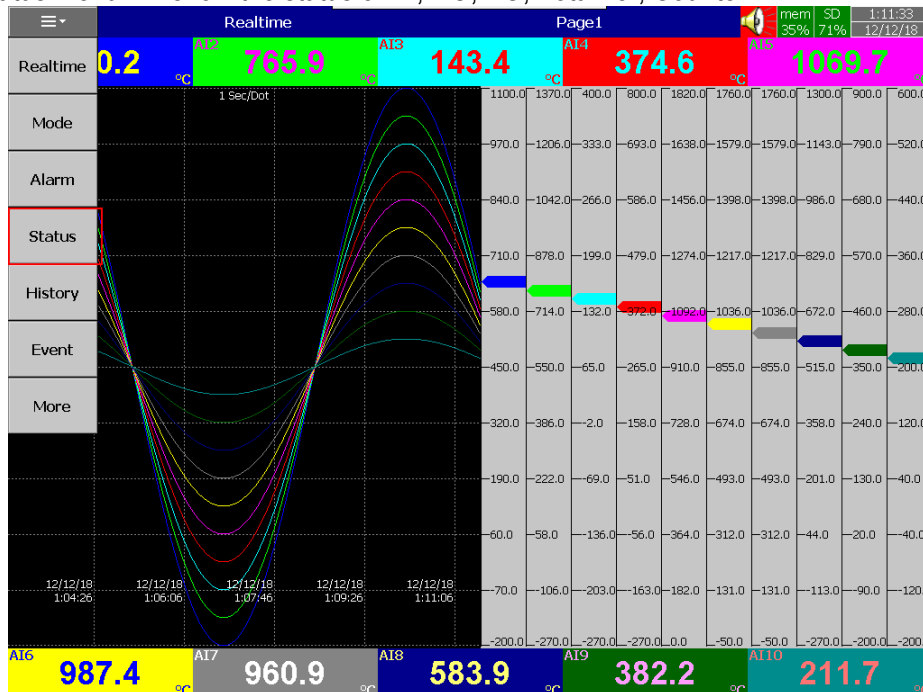
Status menu will show the status of DI, DO, AO, Totalizer, Counter.



By using the DI, DO, AO, Counter, Totalizer tabs the individual status can be viewed in the respective tabs. The selected tab can be changed by using the left and right scroll keys  . The user go back to the home screen by pressing the Home  key. The up down scroll keys

▲ ▼ are used to scroll down the pages in individual tabs. The user can access other menus by pressing the menu ☰ key.





Status				
DI	DO	AO	Counter	Totalizer
No.	Name	Value	Description	
1	DI1	Hi		
2	DI2	60		
3	DI3	Hi		
4	DI4	60		
5	DI5	Hi		
6	DI6	60		
7	DI7	Hi		
8	DI8	60		
9	DI9	Hi		
10	DI10	60		
11	DI11	Hi		
12	DI12	60		

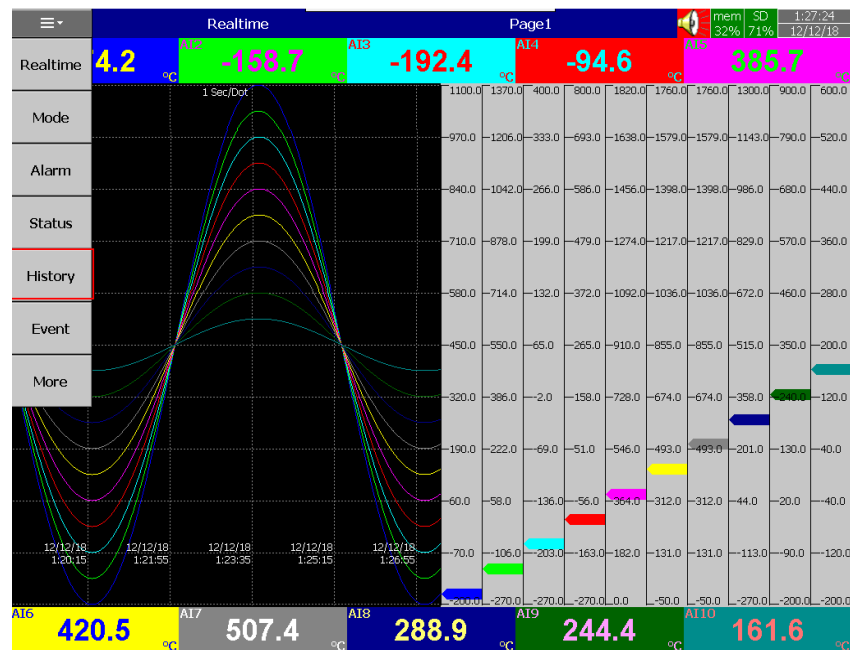

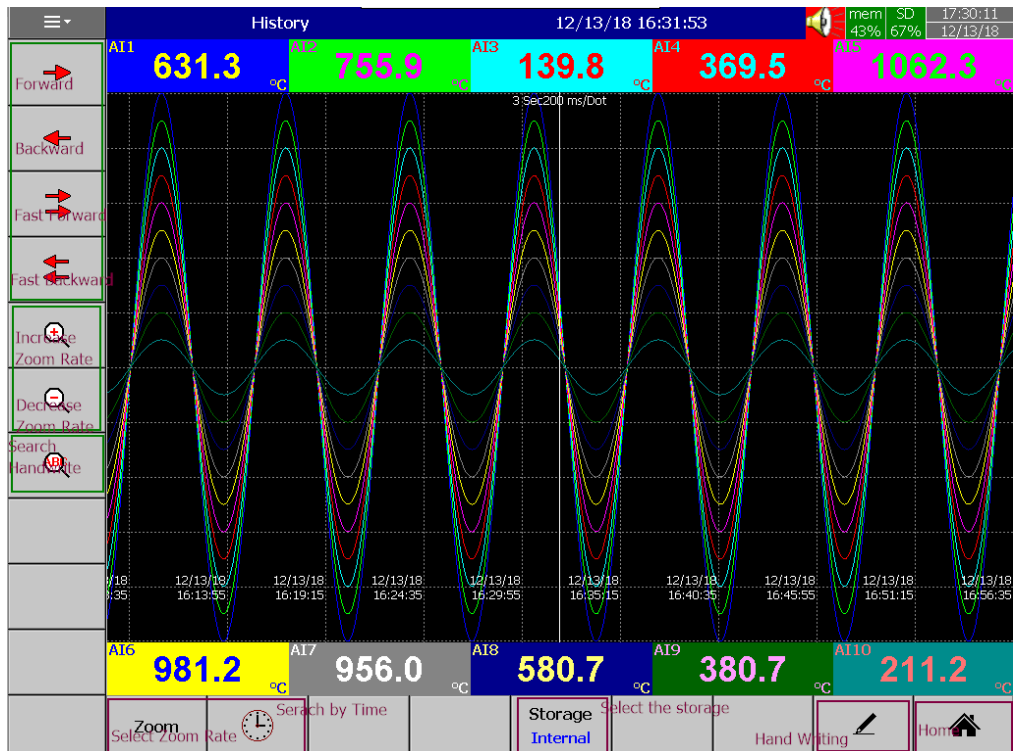
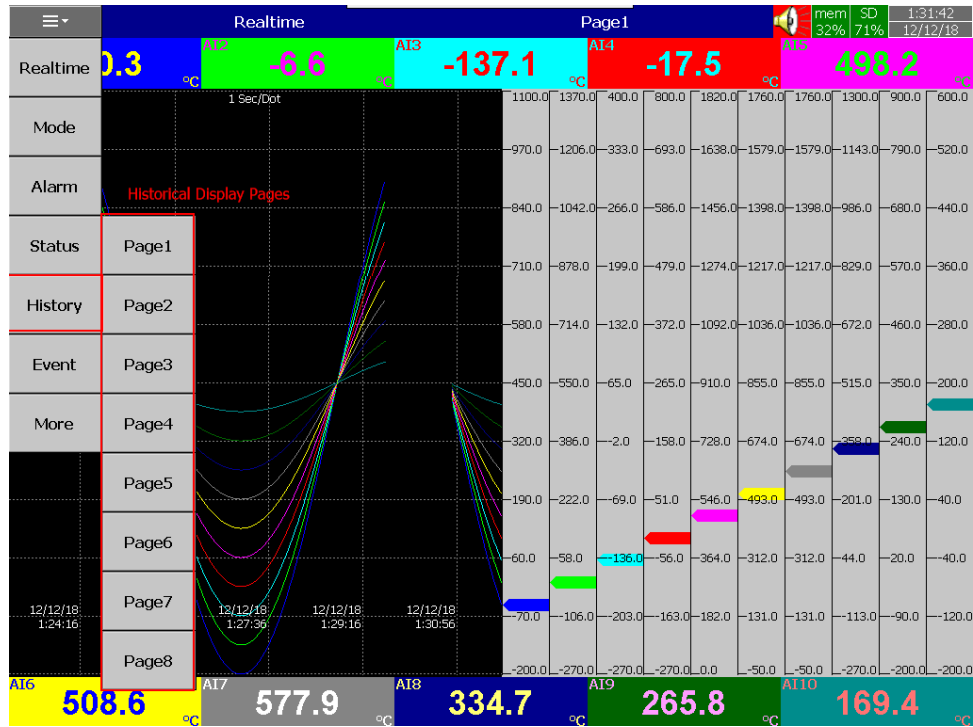
4.1.1.1.5 History

History menu will allow the user to access the historical data of the display pages. The user can select the required historical display page by pressing the required page key in the history menu.





The historical display page will allow the user to navigate the historical data and do the handwritten remarks on the display page. The user can do the navigation on the screen using the four scroll keys . The user can increase or decrease the zoom rate by using the two soft keys . The hand written messages within the data can be searched by using  key. The zoom rate can be selected by using the soft key . The data at the particular time can be searched by the soft key . The location of displayed data can be switched between internal memory

and external memory by using the softkey **Storage Internal**. The user go back to the home screen by pressing the Home  key. The user can access other menus by pressing the menu  key.

4.1.1.1.5.1 Handwriting Messages on Historical Trend Screens

Handwriting Messages on Historical trend screen is a useful feature for the user to highlight important events. The User can write handwritten messages using a stylus on Historical Trend screens.

If the User wants to write a message, then they can press the  pen key in the screen below.

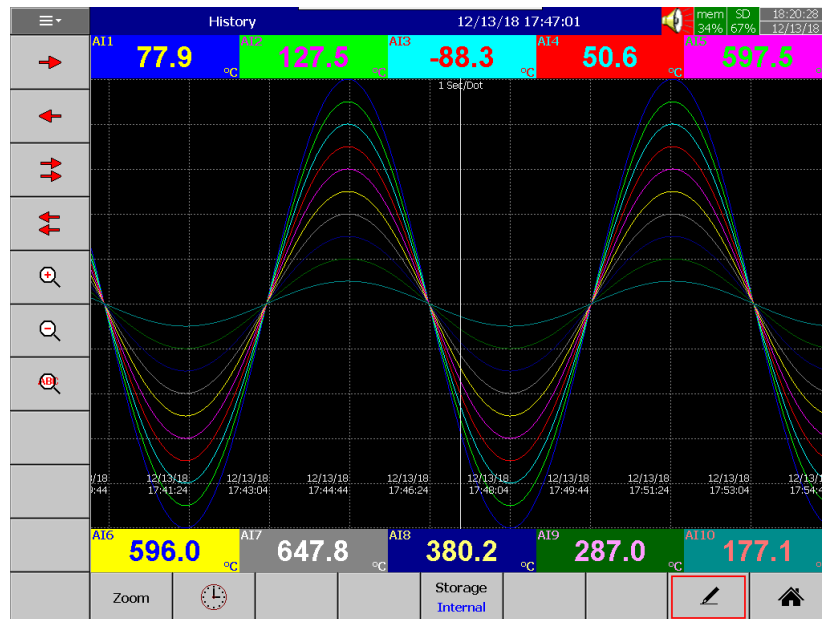

Then using the stylus, the user can write any message in Historical Trend Pages as shown below.

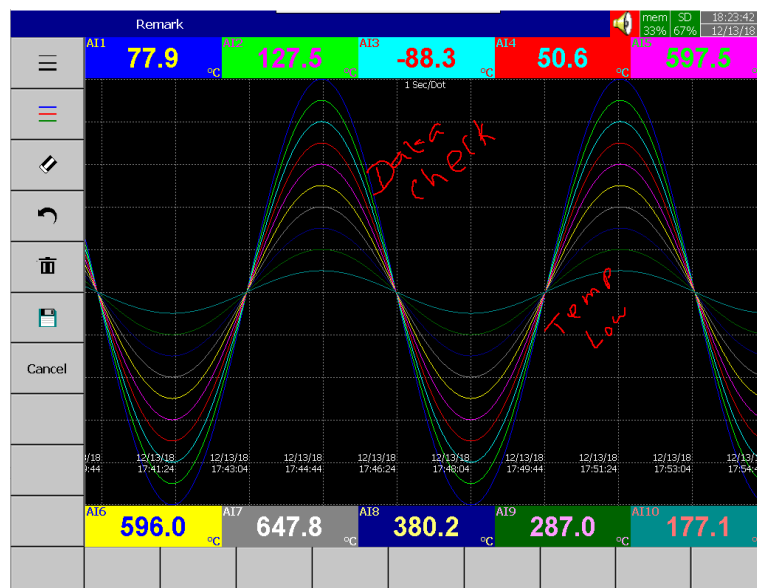

If the User wants to change the width of the written message, he/she can choose the width key  to change the width of the pen.

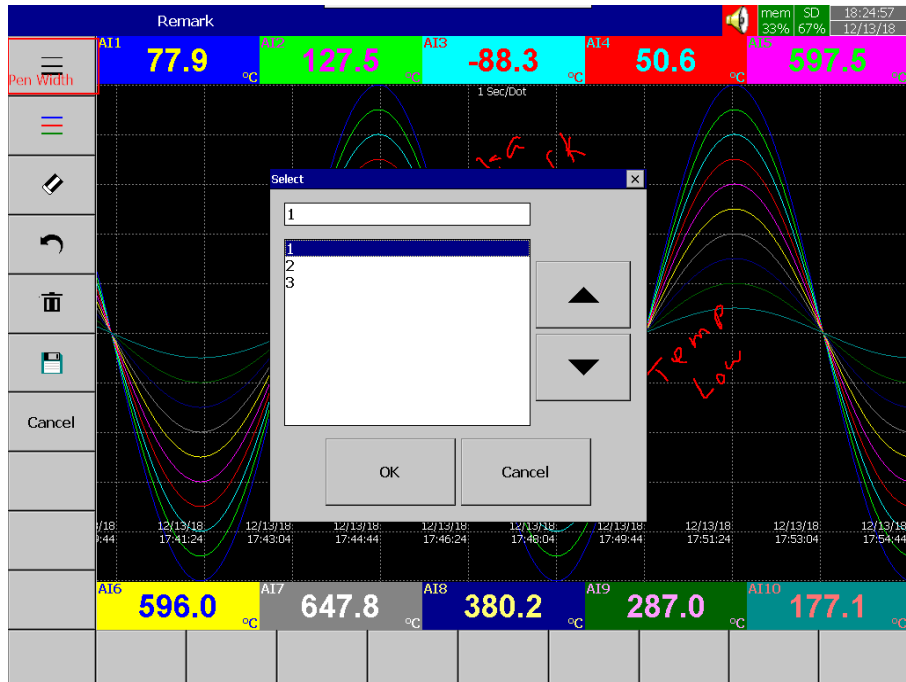

If the User wants to change colour of the pen, he/she can change it by using the  key to change the color of the pen.

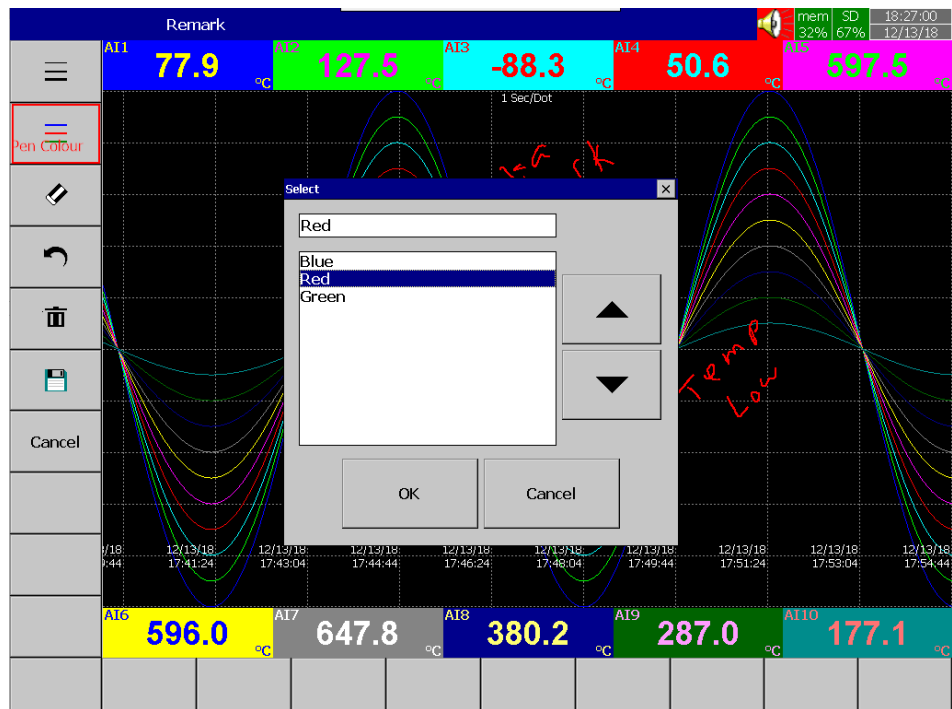

If the User wants to erase part of a message, he/she can do this by using the  key to erase part of the message.

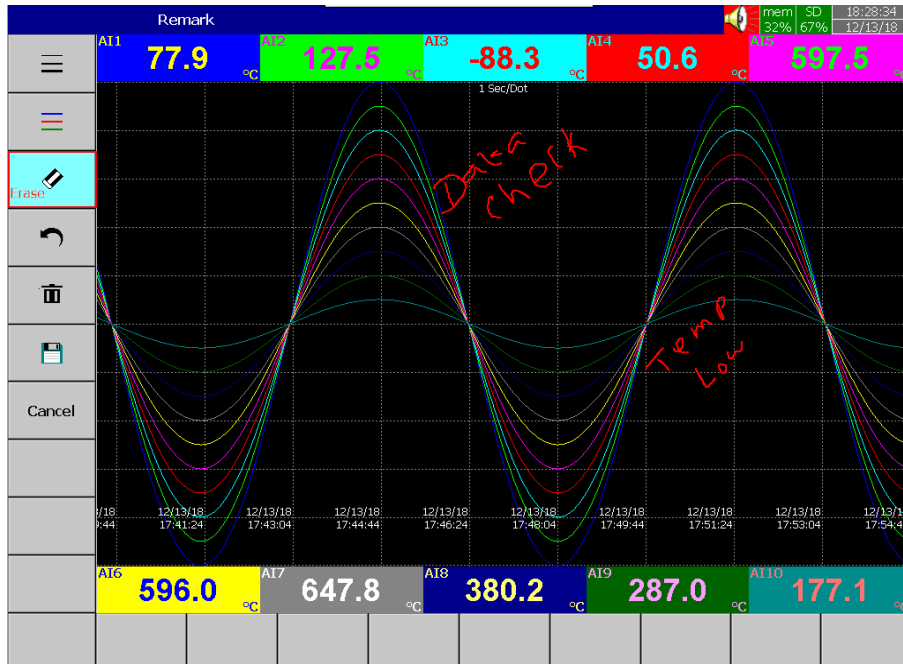

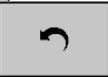
If the user wants to undo part of a message, he/she can do this by using the key  to undo the last part of the message.

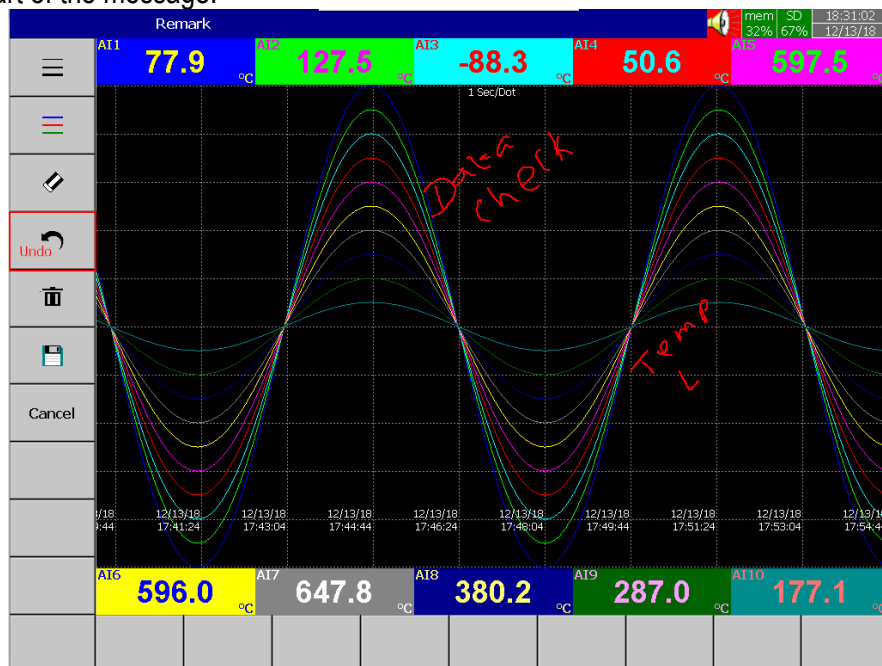

If the User wants to delete the written message, he/she can this do by using the key  to delete the written message.

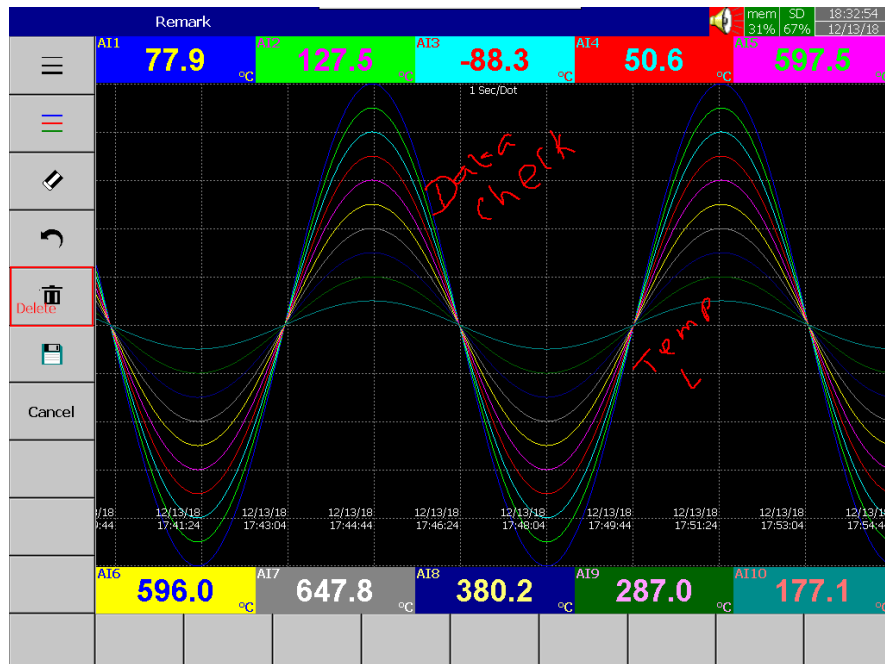



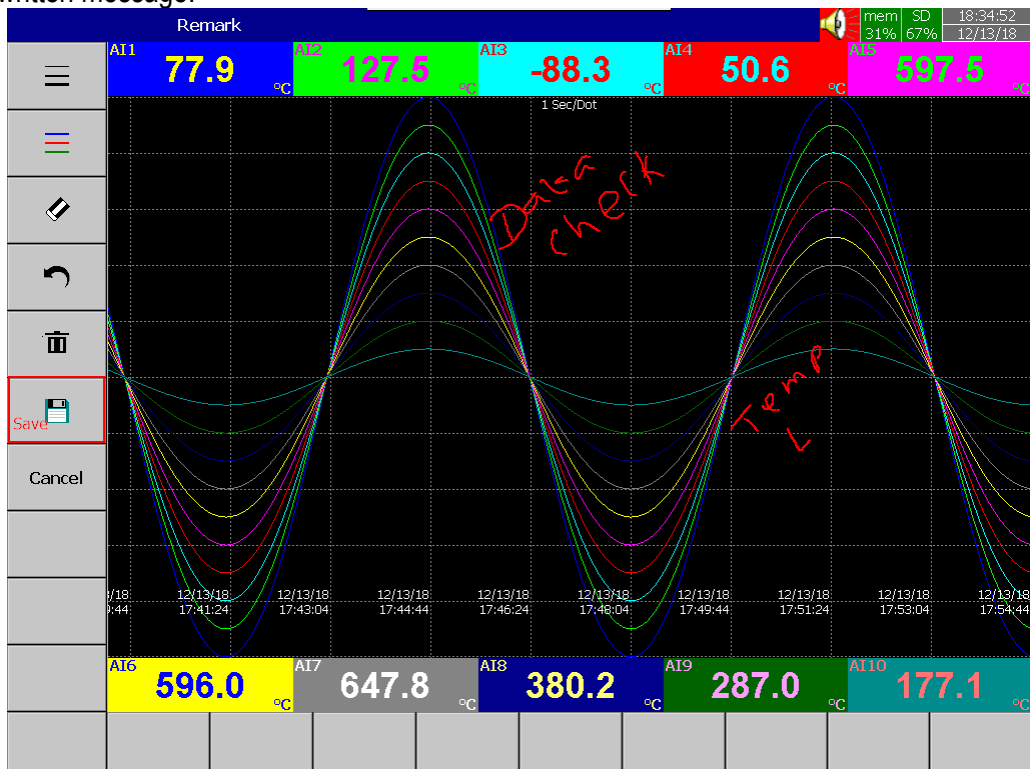

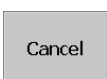

If the user wants to save the written message, he/she can do this by using the  to save the written message.



By using the  key, the user can exit the page without saving the data.



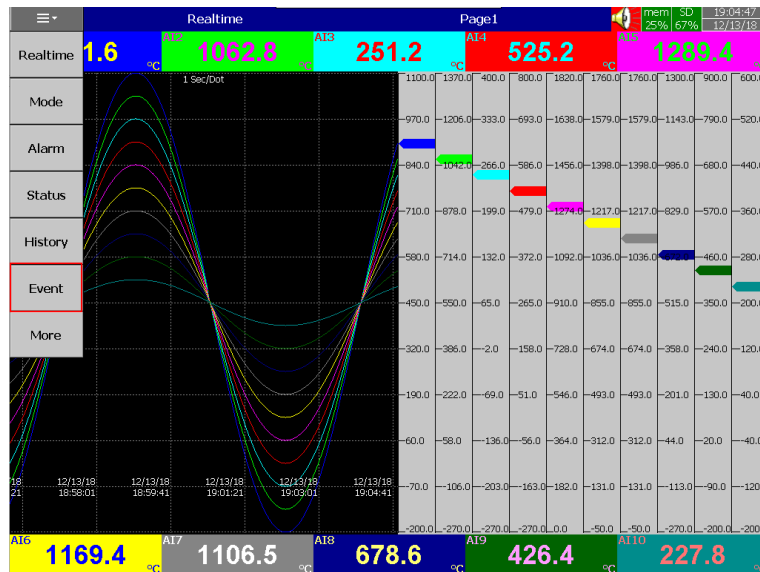

Note: The handwriting messages are saved once can't modified or deleted.

4.1.1.1.6 Event





Event menu will allow the user to access the historical events and reports. By using the Event and Report tabs the event list and report list can be viewed in the respective page. The selected tab can be changed by using the left and right scroll keys . The user go back to the home screen by pressing the Home  key. The up down scroll keys  are used to scroll down the pages in individual tabs. The   keys are used to navigate rows and columns. The user can access other menus by pressing the menu  key.



No.	Active Time	Type	Name	Value	Message
613	11/19/18 18:37:53	LoAlarm	AI14	-69.38	
614	11/19/18 18:38:01	LoLoAlarm	AI13	-303.49	
615	11/19/18 18:38:07	HiAlarm	AI35	2652.80	
616	11/19/18 18:38:38	HiAlarm	AI21	132.00	
617	11/19/18 18:38:38	LoAlarm	AI26	20.00	
618	11/19/18 18:38:46	HHiAlarm	AI21	150.00	
619	11/19/18 18:38:46	HiAlarm	AI22	269.60	
620	11/19/18 18:38:46	LoLoAlarm	AI26	12.50	
621	11/19/18 18:38:46	LoAlarm	AI27	20.00	
622	11/19/18 18:38:49	HiAlarm	AI1	640.3	
623	11/19/18 18:38:49	HiAlarm	AI41	640.22	
624	11/19/18 18:38:55	HiAlarm	AI2	1042.38	
625	11/19/18 18:38:55	HiAlarm	AI42	1184.44	
626	11/19/18 18:38:55	HHiAlarm	AI22	302.09	
627	11/19/18 18:38:55	LoLoAlarm	AI27	12.48	
628	11/19/18 18:38:58	HiAlarm	AI23	80.00	
629	11/19/18 18:38:58	LoAlarm	AI28	20.00	
630	11/19/18 18:39:03	HHiAlarm	AI1	937.6	
631	11/19/18 18:39:03	HiAlarm	AI3	266.03	
632	11/19/18 18:39:03	HHiAlarm	AI41	718.81	
633	11/19/18 18:39:03	HiAlarm	AI43	640.05	
634	11/19/18 18:39:12	HHiAlarm	AI2	1165.55	
635	11/19/18 18:39:12	HHiAlarm	AI42	1326.38	
636	11/19/18 18:39:14	HiAlarm	AI4	536.14	
637	11/19/18 18:39:14	HiAlarm	AI44	1184.25	
638	11/19/18 18:39:26	HHiAlarm	AI3	316.29	
639	11/19/18 18:39:26	HHiAlarm	AI43	718.81	
640	11/19/18 18:39:49	HiAlarm	AI5	1456.00	
641	11/19/18 18:39:49	HiAlarm	AI45	640.00	
642	11/19/18 18:41:25	HHiAlarm	AI13	601.49	
643	11/19/18 18:41:32	HiAlarm	AI15	2652.80	
644	11/19/18 22:54:15	LoAlarm	MemoryFull	5.00	
645	01/01/01 0:00:00	PowerOff			

The Event list can be navigated by using the scroll keys   . The stored location of displayed historical events can be switched between internal memory and SD card by using the softkey .

Report					
Event Report					
12/13/18					
No.	Type	Name	Value	Time	
1	Channel	AI1	1100.0\200.0\449.8 °C	19:08:50	
2	Channel	AI2	1288.0\188.0\549.7 °C	19:08:50	
3	Channel	AI3	333.0\203.0\64.9 °C	19:08:50	
4	Channel	AI4	639.5\109.5\264.9 °C	19:08:50	
5	Channel	AI5	1456.0\364.0\909.8 °C	19:08:50	
6	Channel	AI6	1307.5\402.5\654.9 °C	19:08:50	
7	Channel	AI7	1217.0\493.0\854.9 °C	19:08:50	
8	Channel	AI8	750.5\279.5\514.9 °C	19:08:50	
9	Channel	AI9	460.0\240.0\350.0 °C	19:08:50	
10	Channel	AI10	240.0\160.0\200.0 °C	19:08:50	
11	Channel	AI11	2012.0\328.0\942.4 °F	19:08:50	
12	Channel	AI12	2350.4\306.4\1022.4 °F	19:08:50	
13	Channel	AI13	631.4\333.4\149.2 °F	19:08:50	
14	Channel	AI14	1183.1\165.1\609.2 °F	19:08:50	
15	Channel	AI15	2652.8\687.2\1670.3 °F	19:08:50	
16	Channel	AI16	2385.5\756.5\1571.3 °F	19:08:50	
17	Channel	AI17	2222.8\919.4\1571.2 °F	19:08:50	
18	Channel	AI18	1382.9\535.1\659.1 °F	19:08:50	
19	Channel	AI19	860.0\464.0\662.1 °F	19:08:50	
20	Channel	AI20	464.0\320.0\392.0 °F	19:08:50	
21	Channel	AI21	180.0\60.0\99.9 °C	19:08:50	
22	Channel	AI22	312.8\32.8\139.9 °F	19:08:50	
23	Channel	AI23	80.00\30.00\49.99 %	19:08:50	
24	Channel	AI24	70.00\30.00\49.99 %	19:08:50	
25	Channel	AI25	60.00\40.00\50.00 %	19:08:50	
26	Channel	AI26	100.00\0.00\50.02 %	19:08:50	
27	Channel	AI27	90.00\10.00\50.02 %	19:08:50	
28	Channel	AI28	80.00\20.00\50.01 %	19:08:50	
29	Channel	AI29	70.00\30.00\50.01 %	19:08:50	
30	Channel	AI30	60.00\40.00\50.00 %	19:08:50	
31	Channel	AI31	2012.0\328.0\941.5 °F	19:08:50	
32	Channel	AI32	2350.4\306.4\1021.5 °F	19:08:50	
33	Channel	AI33	631.4\333.4\148.8 °F	19:08:50	

The Report list can be navigated up and down by using   keys. The report of previous and next day, week, month depends on the selection of mode can be navigated by using   keys. The mode can be switched between List, Daily, Weekly, Monthly by using  key.

4.1.1.1.7 More

More menu will allow the users to access more menus for the operation. The more consists of the below menus.

1. Dump
2. Clear
3. Operate
4. Config
5. Stop
6. Logout
7. Batch
8. Shutdown

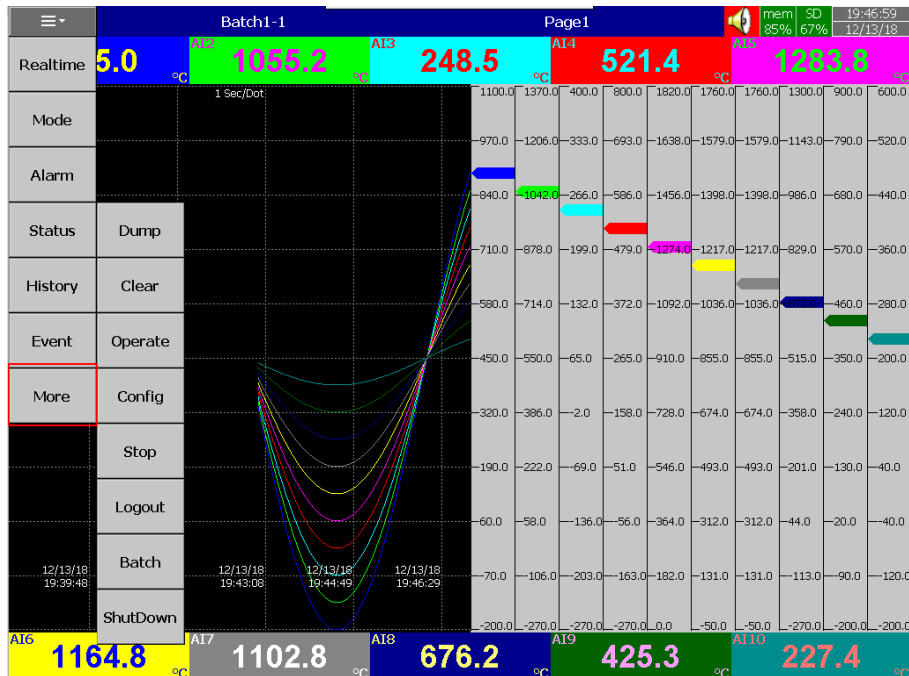
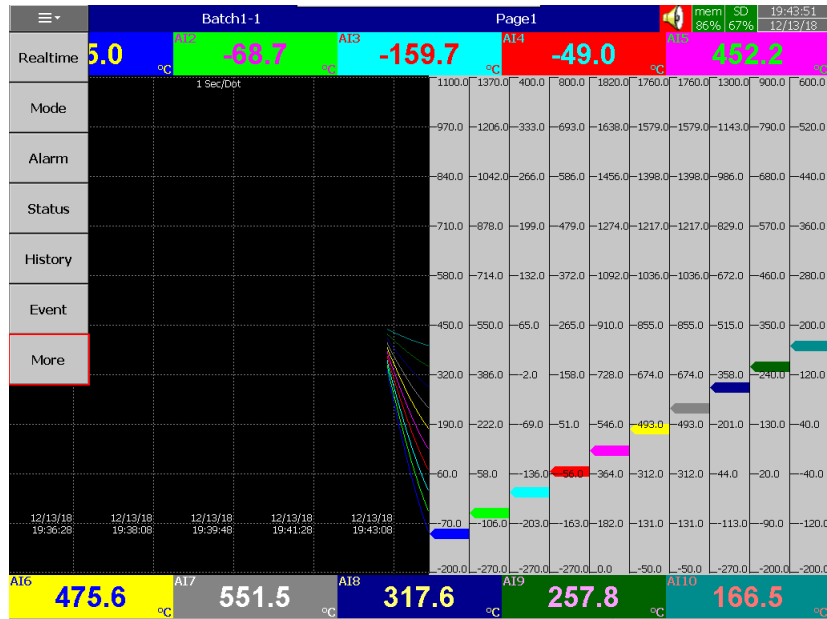

4.1.1.1.7.1 Dump

Dump the historical data from internal memory to external memory such as SD Card or USB Disk. The user can select the data to be dumped to external memory. The recorder will allow the user to

select the period to be dumped after pressing the  key. The available period option to be selected will be differ for normal mode and batch mode.

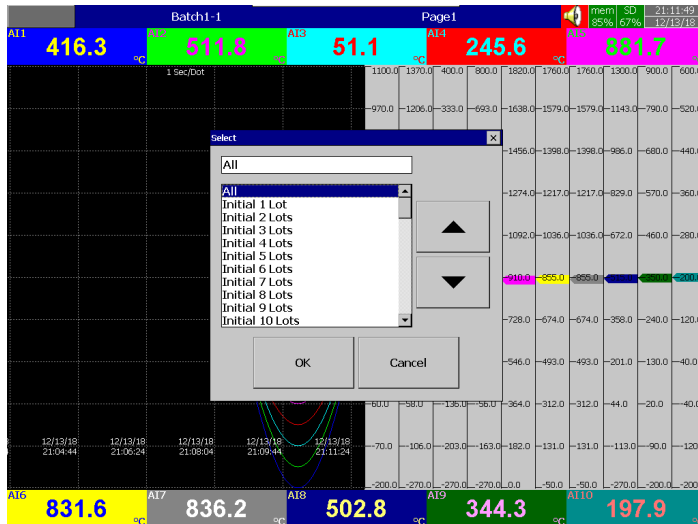

Dump Option-Batch Mode

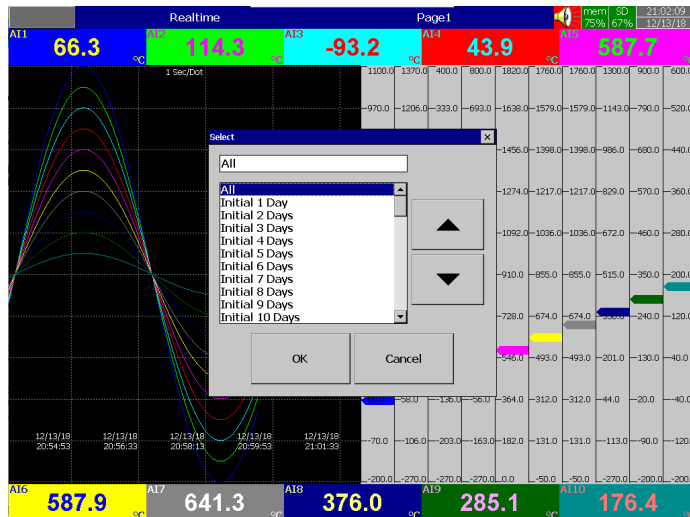

Dump Option- Normal Mode

4.1.1.1.7.2 Clear

Clear all the historical data and event list stored in the memory. The user can select the data to be cleared. The recorder will allow the user to select the period to be cleared after pressing the  key. The available option period to be selected will be differ for normal mode and batch mode.

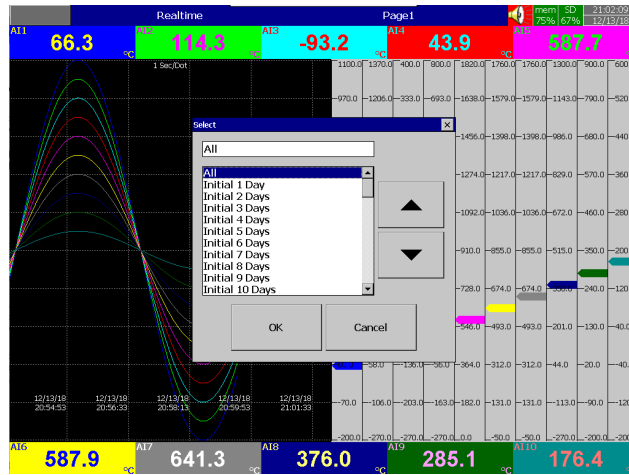

Clear Option- Normal Mode

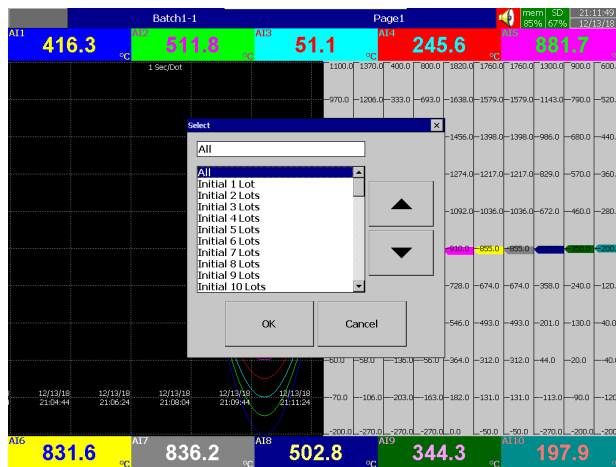

Clear Option-Batch Mode

4.1.1.1.7.3 Operate

Manually operate the jobs from the available jobs directly without any events. The details of all the jobs are explained in [section 5.3](#).

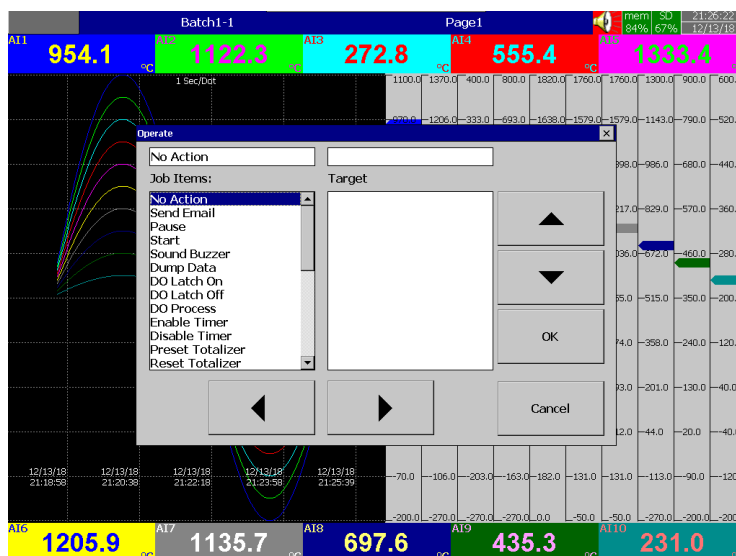

4.1.1.1.7.4 Config

This will allow the user to access the configuration page. The configuration page configuration is explained in [Chapter 5](#).

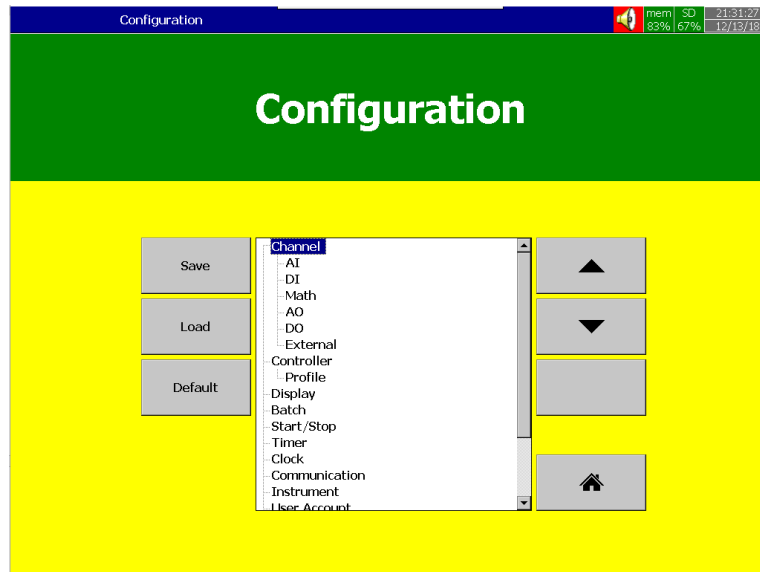

4.1.1.1.7.5 Stop

Stop the batch and logging. The Title bar will show pause when the logging is stopped.

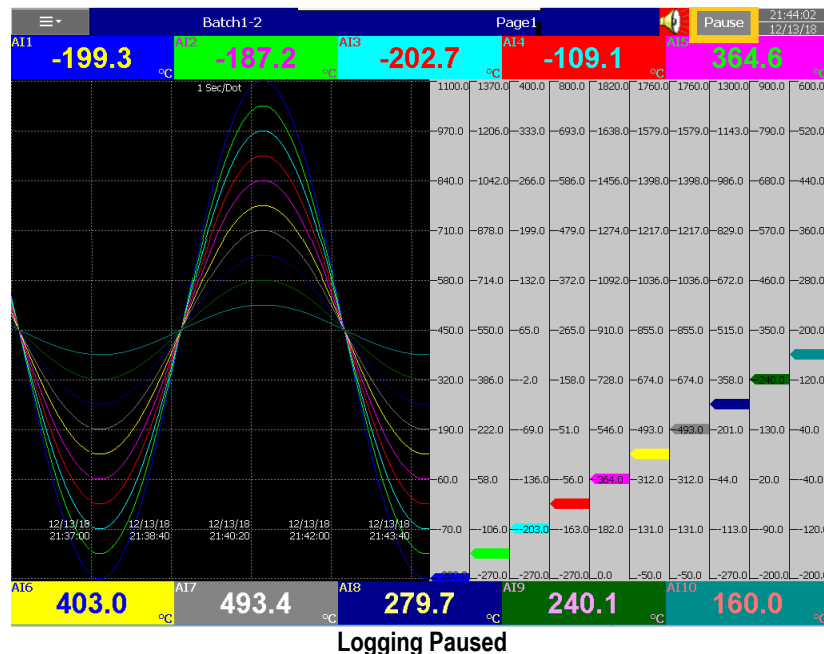

4.1.1.1.7.6 Logout

Logout the user.

4.1.1.1.7.7 Batch

The user can configure the batch related information. The information can be configured are Batch name, Lot no, Batch comments. There are 10 comments are available for the user to configure.

The comments can be navigated by using   keys. The Batch name and lot no can't be edited during the batch is running.

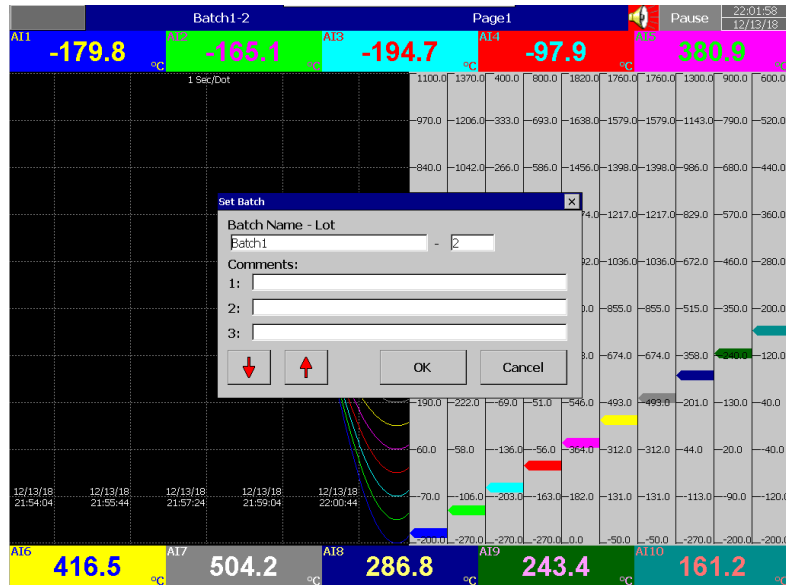

4.1.1.1.7.8 Shutdown

Shutdown the recorder.

5. CONFIGURATION

This section will explain about the procedure to configure the recorder. Press  (Menu), then **More** and then **Config** soft key to enter Configuration mode. A tree type layout appears with a provision to configure Channel, Tools, Message, Display, Instrument, Security, Auto-Output, Demo, and system Information. In addition, the Save, Load, Default and Home soft buttons also appear.

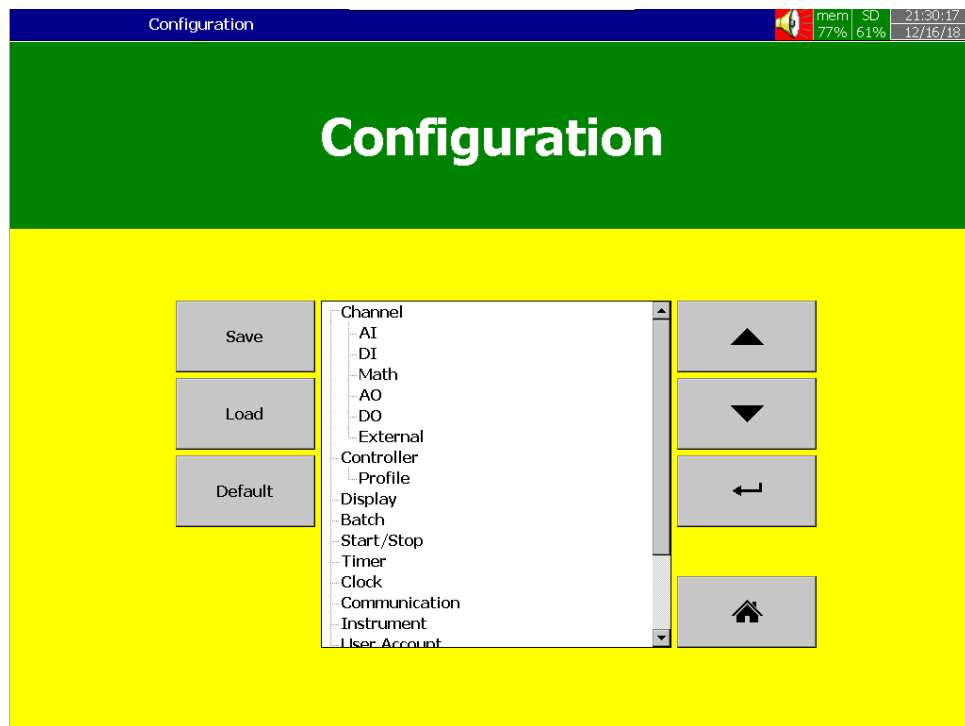
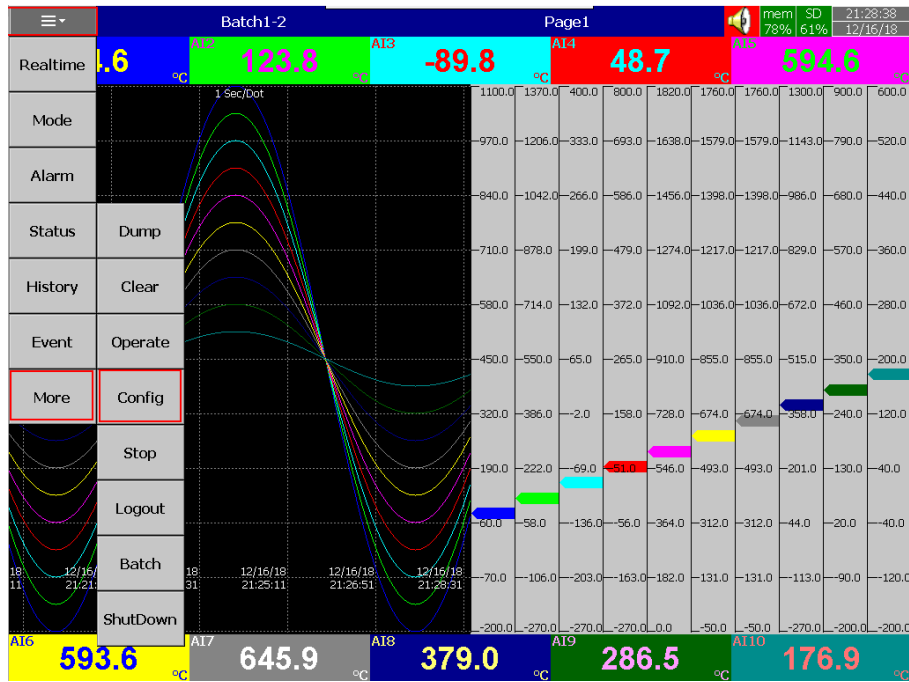

There are four soft keys are available in the configuration page for the menu navigation. They are as below.



Various options are available to enter into configuration page menus.

Option-1: Select the required menu by using up & down directional keys, then press “Enter” key

Option-2: Select the required menu directly with a touch, then press “Enter” key

Option-3: Select the required menu by pressing the menu two times quickly, it is same as a double click from a mouse

There are four soft key are available to save, load, to load the default settings and move to home screen. They are below.

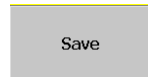

Save

Save configuration from the recorder to a USB disk or an SD Card.



Load

Load configuration from a USB Disk or SD Card to the recorder.



Default

Load the factory default setting to the configuration menu parameters.



Home

Returns the display back to the home page.

5.1 Channel

This section will explain the configuration of different types of channels. They are as below.



1. Analog Input (AI)
2. Digital Input (DI)
3. Math
4. Analog Output (AO)
5. Digital Output (DO)
6. External device channels.

5.1.1 Analog Input

After entering the Configuration menu, in “Channel”, select “AI”, then Press the “Enter” key to get into Analog Input Channel configuration menu. It displays the Analog input **AI1** as the first analog input

channel configuration page. Press directional navigation keys  at the bottom to select

other channels. Press directional keys  on the right hand side to select the column.

After completing Configuration, press  soft key, then press  soft key to return to main display. All configurations will be saved automatically.

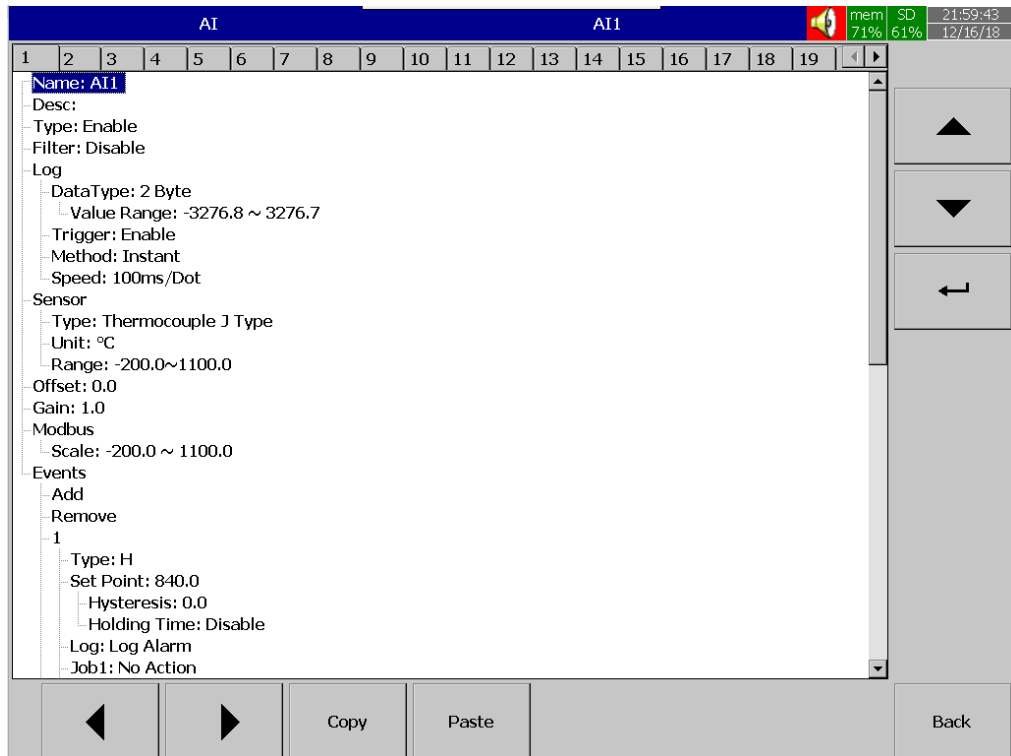

Copy: copy the channel configuration from one channel to another channel.

Paste: Paste the copied configuration to the channel.

Press Copy key in the source channel and press paste key in the destination channel.

5.1.1.1.1 Name

Enables the User to define the name for each channel with a maximum of 18 characters. Select "Name", then Press "Enter", soft key, a keyboard with several keys will appear. Press "Shift" to select special characters. Press "Caps" to select capital letters. Press soft key "OK" after entering a new channel name.

5.1.1.1.2 Desc

The description about a specific channel on the recorder.

5.1.1.1.3 Type

Option available to enable or disable the channel

5.1.1.1.4 Filter

It is to reduce the noise of input signal before logging. The filter can be set from 1 second to 16 seconds. It is a soft filter available to reduce fast variation of analog inputs. There are two types of filters available for the users to select. They are moving average and difference.

5.1.1.1.4.1 Moving Average

This will log average of the values sampled in the configured Buffer Time.

For example, if the filter value is set as 5 sec for AI1, it means all the samples collected in the last 5 sec shall be averaged, and the averaged value is available to record as per Log method.

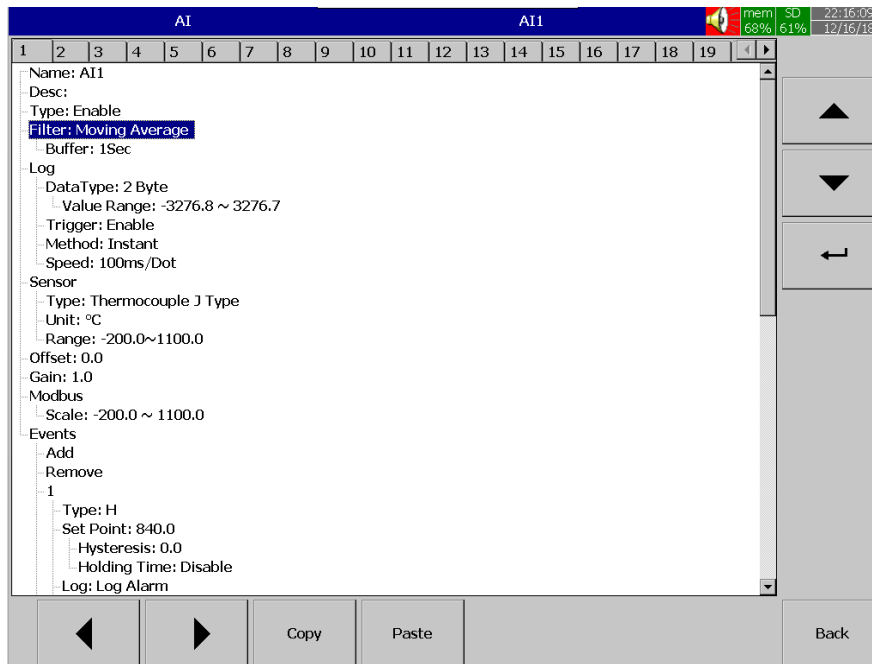

5.1.1.4.2 Difference

This will log the data only there is at least a difference between the current data and the last logged data for a period. The difference will be defined by allowance and the period is defined by holding time.

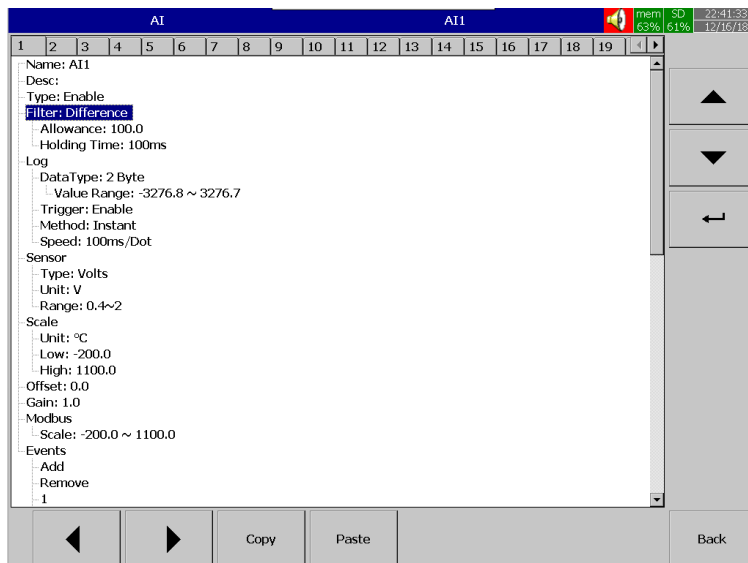

For example, the allowance is set for 100 and the holding time is set for 100 msec. If current value is 1000 and last value is 890, when you check the difference is 110. Since this difference is greater than 100 it is with that value more than the holding time 100 msec, this value will be recorded. If the difference of current and last recorded value is greater than “difference value” but does not stay for the duration of holding time, this value will not be recorded. So the holding time will define the duration of noise filter.

5.1.1.5 Log

5.1.1.5.1 Data Type

The data type for logging is 2 byte.
2 byte range: -32767 to +32767

5.1.1.5.2 Trigger

Two options are available for the user to select.

1. **Disable:** Select disable while the recording of a specific channel is not required at this time
2. **Enable:** Select enable while the recording of a specific channel is required at this time

5.1.1.5.3 Method

This is the method of logging measured data. Select the column **Method** and press **Enter**. Then choose the required Log method from the available methods Instant, Average, Minimum or Maximum of data.

5.1.1.5.3.1 Instant

Logging the last measured data at the logging interval

5.1.1.5.3.2 Average

Logging the averaged of sampled measured data at the logging interval

5.1.1.5.3.3 Minimum

Logging the minimum of sampled measured data at the logging interval

5.1.1.5.3.4 Maximum

Logging the maximum of sampled measured data at the logging interval

5.1.1.5.4 Speed

It is the logging speed (recording speed) of measured data. The available log speeds are as below.

1. 100 msec/dot
2. 1 Sec/dot
3. 2 Sec/dot
4. 5 Sec/dot
5. 10 Sec/dot
6. 15 Sec/dot
7. 20 Sec/dot
8. 30 Sec/dot
9. 1 min/dot
10. 2 min/dot
11. 5 min/dot
12. 15 min/dot
13. 1 hour/dot
14. 2 hour/dot

5.1.1.6 Sensor

Sensor

Type: Thermocouple K Type, °C

Unit: °C

Range: -200.0~1370.0

5.1.1.6.1 Type

Select the input type of the sensor for the channel.

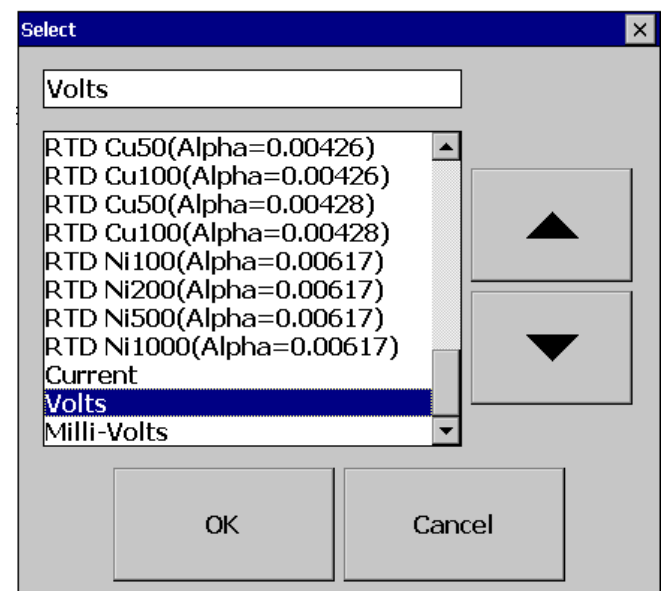
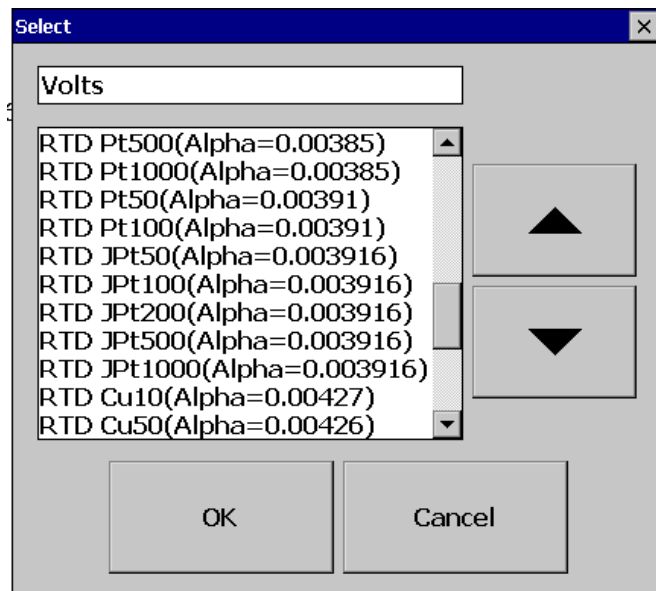
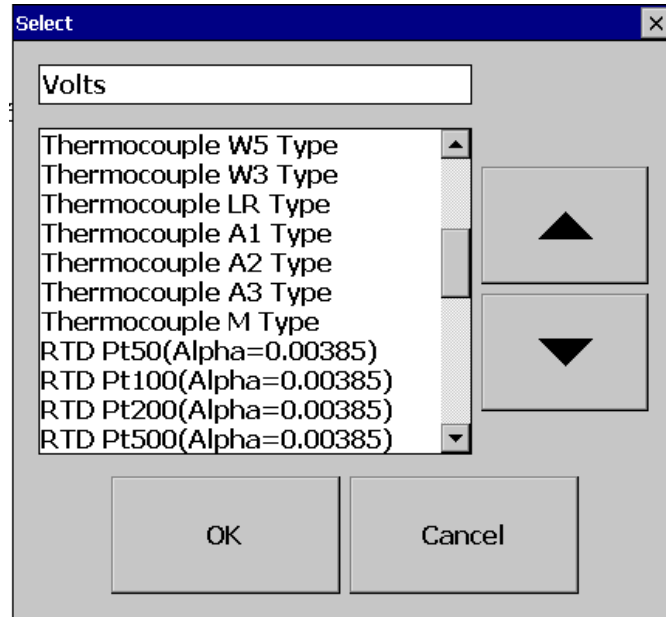
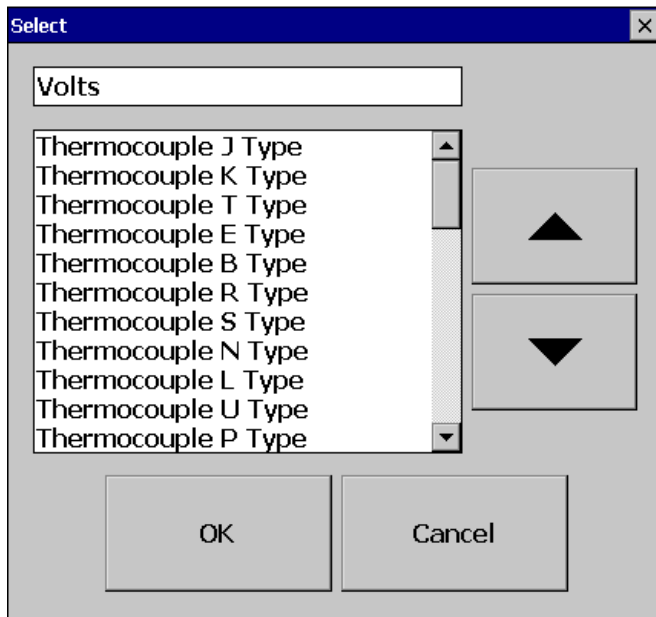

5.1.1.6.2 Unit

The engineering unit of input.

5.1.1.6.3 Range

Select the range for the input based on Sensor type

5.1.1.6.4 Scale

Appears only for linear input type. The user can scale the input to the engineering unit as per the application requirement.

5.1.1.7 Offset

It is to offset the input value to correct the sensor error.

5.1.1.8 Gain

It is a multiplier to correct the sensor error.

The correct value = (the process value x gain) + offset

5.1.1.9 Modbus

The scaling of the channel value in Modbus communication.

5.1.1.10 Events

Events are frequently used for Alarm purposes. The events can be used to operate digital outputs (DO), Timer, Totalizer, Counter or Report. There are maximum five events can be added to each analog input.

Press "Add" to add new event and Press "Remove" to remove selected event

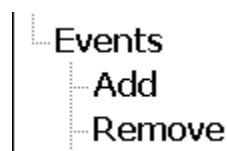

5.1.1.10.1 Type

There are various types of events are available for the user to select for job or alarm purpose. They are listed as below.

5.1.1.10.1.1 H

It is high event. When the process value is higher than high limit, then the alarm or job associated with this event is actuated.

5.1.1.10.1.2 L

It is low event. When the process value is lower than low limit, then the alarm or job associated with this event is actuated.

5.1.1.10.1.3 HH

It is high high event. When the process value is higher than high high limit, then the alarm or job associated with this event is actuated. This is another limit higher than high limit for double warning.

5.1.1.10.1.4 LL

It is low low event. When the process value is lower than low low limit, then the alarm or job associated with this event is actuated. This is another limit lower than low limit for double warning.

5.1.1.10.1.5 Dev+

It is deviation+ event. This event will be triggered on the positive deviation of process value. The job or alarm is activated when the process value is deviated by the value higher than set point from the previous process value.

For example,
Set point = 10
At 10.00.01 Hrs, Tag 1 = 40
At 10.00.02 Hrs, Tag 1 = 51
Then, job or alarm is activated

5.1.1.10.1.6 Dev-

It is deviation - event. This event will be triggered on the negative deviation of process value. The job or alarm is activated when the process value is deviated by the value lower than set point from the previous process value.

For example,
Set point = 10
At 10.00.01 Hrs, Tag 1 = 40
At 10.00.02 Hrs, Tag 1 = 29
Then, job or alarm is activated.

5.1.1.10.1.7 Error

It is error event. This event will be activated when there is an error on the input of the channel.

5.1.1.10.2 Set point

Set point for the event.

5.1.1.10.2.1 Hysteresis

To avoid the alarm or event been activated too often, Hysteresis value can be defined for the event trigger set point.

5.1.1.10.2.2 Holding time

To avoid the alarm or event been activated too often, the holding time can be defined for the event trigger set point. In process sometimes SP is reached but it will go down immediately, this might due to process instability. To avoid these kind of nuisance situations, the holding time can be used to see that PV stays at above that SP more than the holding time and then only activate the action for that event. The range of holding time can be set from 1 min to 60 min.

5.1.1.10.3 Log

The event can be logged as alarm or event. They can be selected from the available options. They are as below.

5.1.1.10.3.1 Log Alarm

Log the event as Alarm.

5.1.1.10.3.2 Log Alarm (Auto Ack)

Log the event as alarms and acknowledge automatically

5.1.1.10.3.3 Log Event

Log as event

5.1.1.10.4 Job 1 & Job 2

The job is called as a task to be performed when the event is activated. There are two jobs Job1 and Job2 can be added to perform in any event.

A typical example is to trigger **an alarm buzzer** in the event of a high temperature. Each channel can accept five different types of events (or alarms) and each event can create two jobs. Please note that a job under Event is different from a job perform by **Operate** key. The job is actuated by an event, and the Operate is actuated by manual control, no event necessary.

Note: Please refer to the section [Jobs](#) for full details about various jobs available

Note: Number of analog inputs shown on the AI screen depends on number of Analog input cards inserted in the paperless recorder.

Example:

If the temperature is increased to more than 120 °C, logs alarm and switches on digital output1 only after 1 minute holding time defined in the setting. When the temperature is decreased to less than 80 °C, logs the alarm and switches off the digital output 1 only after 1 minute holding time defined in the setting.

Setting of events for the analog input in the channel configuration is as follows,



1	Type: H Set Point: 120.0 Hysteresis: 0.0 Holding Time: 1 Min Log: Log Alarm Job1: DO Latch On_DO1 Job2: No Action
2	Type: L Set Point: 80.0 Hysteresis: 0.0 Holding Time: 1 Min Log: Log Alarm Job1: DO Latch Off_DO1 Job2: No Action

5.1.2 Digital Input

After entering the Configuration menu, in the Channel, select DI then Press the “**Enter**” soft key to get into Digital Input Channel configuration menu. . It displays the Digital input **DI 1** as the first digital input

channel configuration page. Press directional navigation keys  at the bottom to select

other channels. Press directional keys  on the right hand side to select the column.

After completing Configuration, press  soft key, then press  soft key to return to main display. All configurations will be saved automatically.

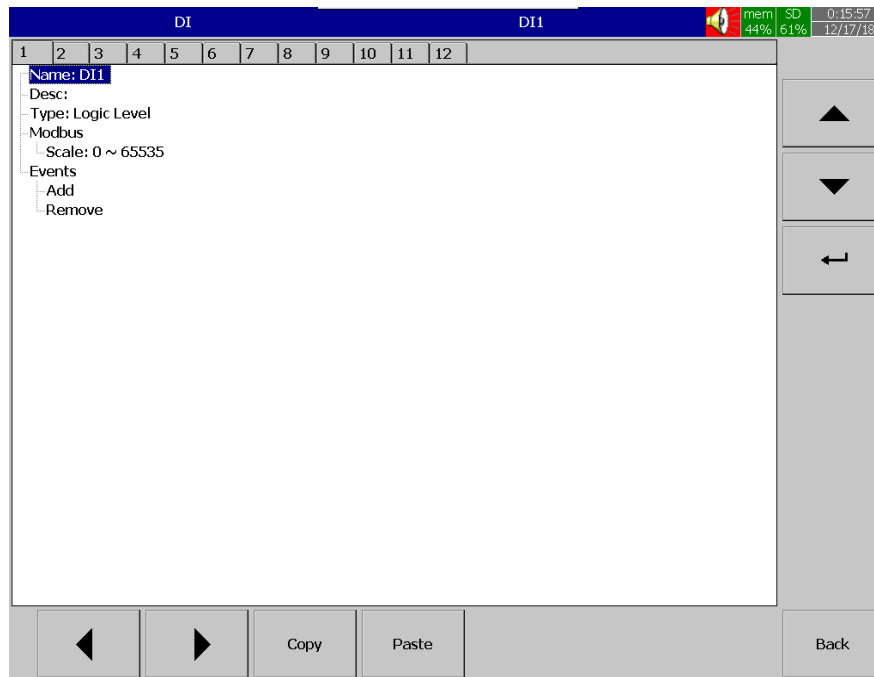

Copy: copy the channel configuration from one channel to another channel.

Paste: Paste the copied configuration to the channel.

Press Copy key in the source channel and press paste key in the destination channel.

5.1.2.1.1 Name

Enables the User to define the name for each channel with a maximum of 18 characters. Select "Name", then Press "Enter", soft key, a keyboard with several keys will appear. Press "Shift" to select special characters. Press "Caps" to select capital letters. Press soft key "OK" after entering a new channel name.

5.1.2.2 Desc

The description about a specific channel on the recorder.

5.1.2.3 Type

Type of Digital input. The digital input can be configured as Logic Level and pulse counter. To select the type press the Type and then select the required type.

5.1.2.3.1 Logic Level

This selection activates digital logic, which is either one or zero with low frequency which is less than 1Hz, such as an external relay.

5.1.2.3.2 Pulse Counter

This selection will allow the digital input to read the high speed pulse inputs up to 100 Hz. This is useful to get the flow rate from pulse output from flow meters.

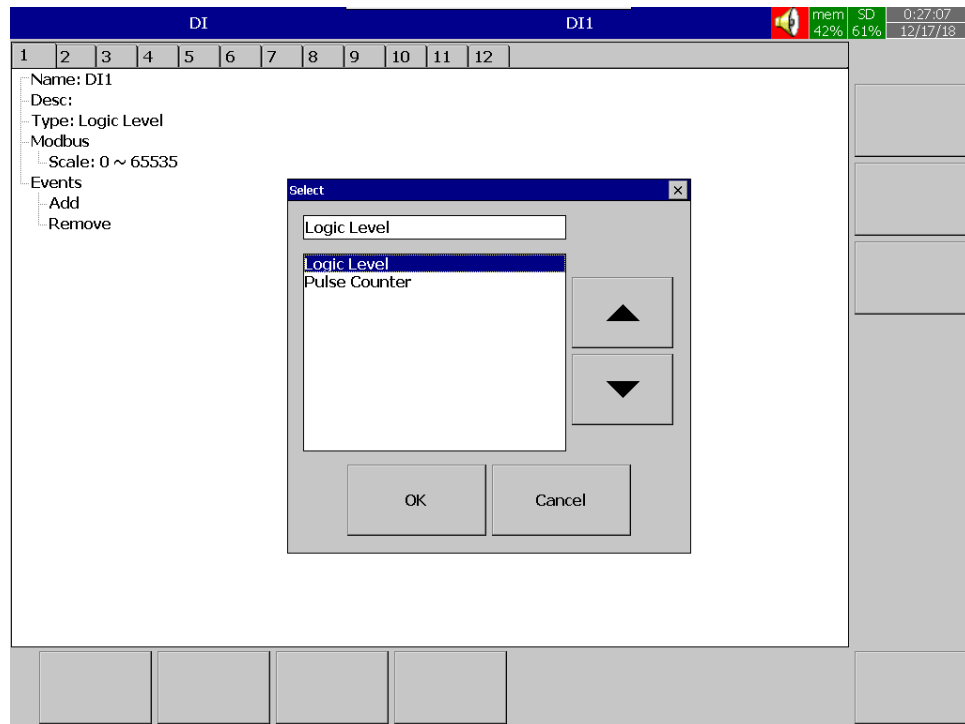

5.1.2.4 Events

A maximum of 2 events are supported for every digital Input channel. A maximum of two jobs can be configured for each event.

***Note:** Events will not appear if Logic Level selected as Pulse Counter

Press "Add" to add new event and press "Remove" to remove selected event



5.1.2.4.1 Type

Select the event type Low L or High H

5.1.2.4.1.1 Holding time

To avoid the alarm or event been activated too often, the holding time can be defined for the event trigger set point. In process sometimes SP is reached but it will go down immediately, this might due to process instability. To avoid these kind of nuisance situations, the holding time can be used to see that the DI stays at high or low more than the holding time and then only activate the action for that event. The range of holding time can be set from 1 min to 60 min.

5.1.2.4.2 Job1, Job2

The job is called as a task to be performed when the event is activated. There are two jobs Job1 and Job2 can be added to perform in any event.

To configure a Job, select Job1, thepress the Enter key. It will show a list of all the available jobs. Select the required Job.

Note: Number of digital inputs shown on the DI screen depends on number of Digital input cards inserted in the paperless recorder.

Example:

After pressing a “Start” switch, latch ON Digital Output1, after pressing a “Pause” switch, latch Off Digital Output1.

Start Timer, Stop Timer, Reset Totalizer, Reset Counter, Reset MaxMinAve values of all the channels etc.

It is possible to display Digital input status via status bar on any display page in the paperless recorder. If digital input is not enabled then it shows as “Low”. If digital input is enabled then it shows as “High”. To configure status bar, refer section [Display](#)

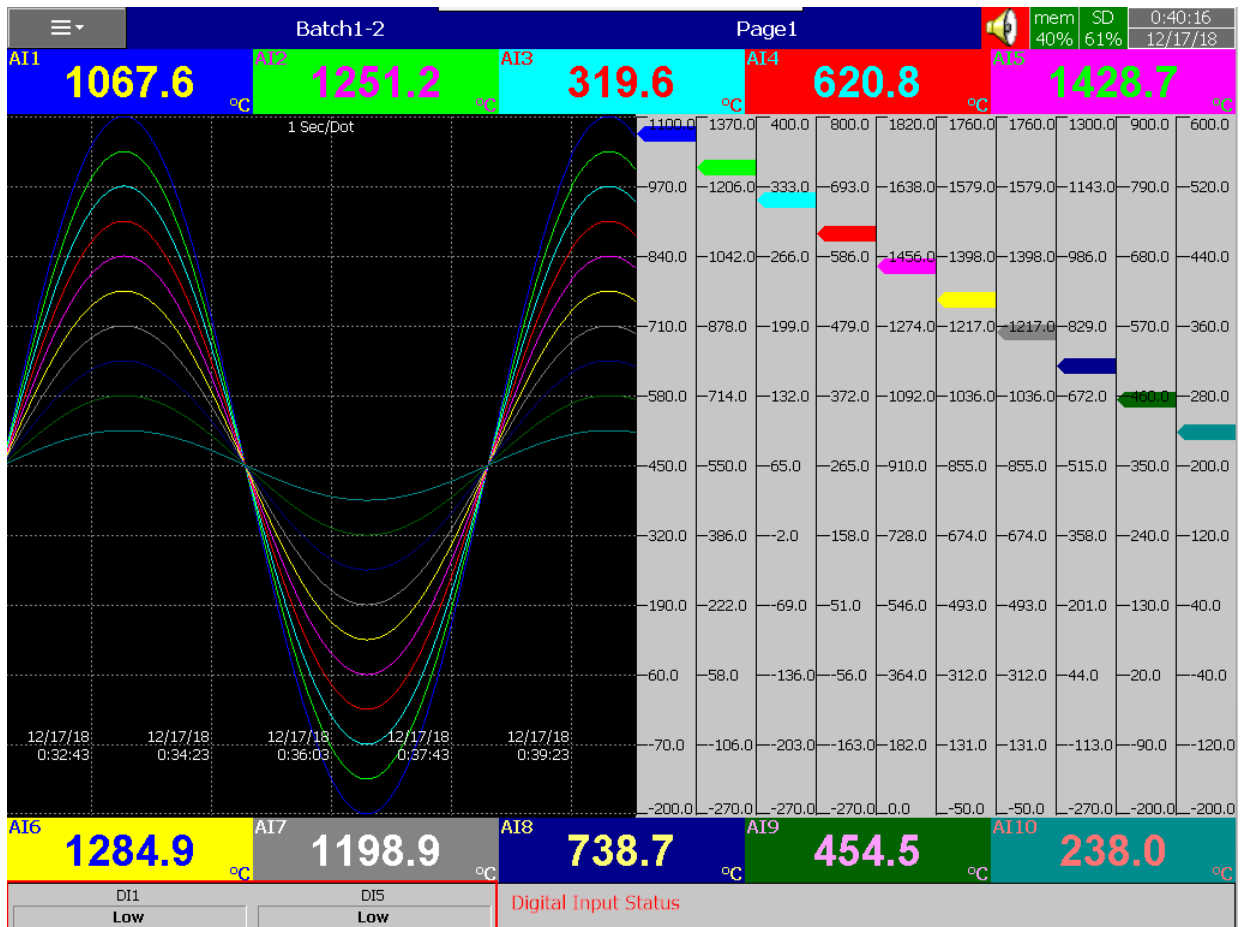

Digital Input status can also be monitored from the  (Menu). Press “Status” and then select “DI”, it will show the Digital Input Status as follows.

DI	DO	AO	Counter	Totalizer	
No.	Name		Value	Description	
1	DI1		Low		
2	DI2		60		
3	DI3		Low		
4	DI4		60		
5	DI5		Low		
6	DI6		60		
7	DI7		Low		
8	DI8		60		
9	DI9		Low		
10	DI10		60		
11	DI11		Low		
12	DI12		60		

5.1.3 Math Channel



The Math channel is used to do the mathematical operations. The Math channel can be configured as Math or counter or Totalizer. The maximum no of math channel in different PPS recorders as below.

PR Recorder	PPS-1000	PPS-2000	PPS-3000
Maximum Math Channels	15	40	60

After entering the Configuration menu, in the Channel, select Math then Press the “**Enter**” soft key to get into Math Channel configuration menu. It displays the Math channel **Math1** as the first math

channel configuration page. Press directional navigation keys   at the bottom to select

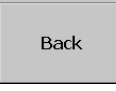
other channels. Press directional keys   on the right hand side to select the column.

After completing Configuration, press  soft key, then press  soft key to return to main display. All configurations will be saved automatically.

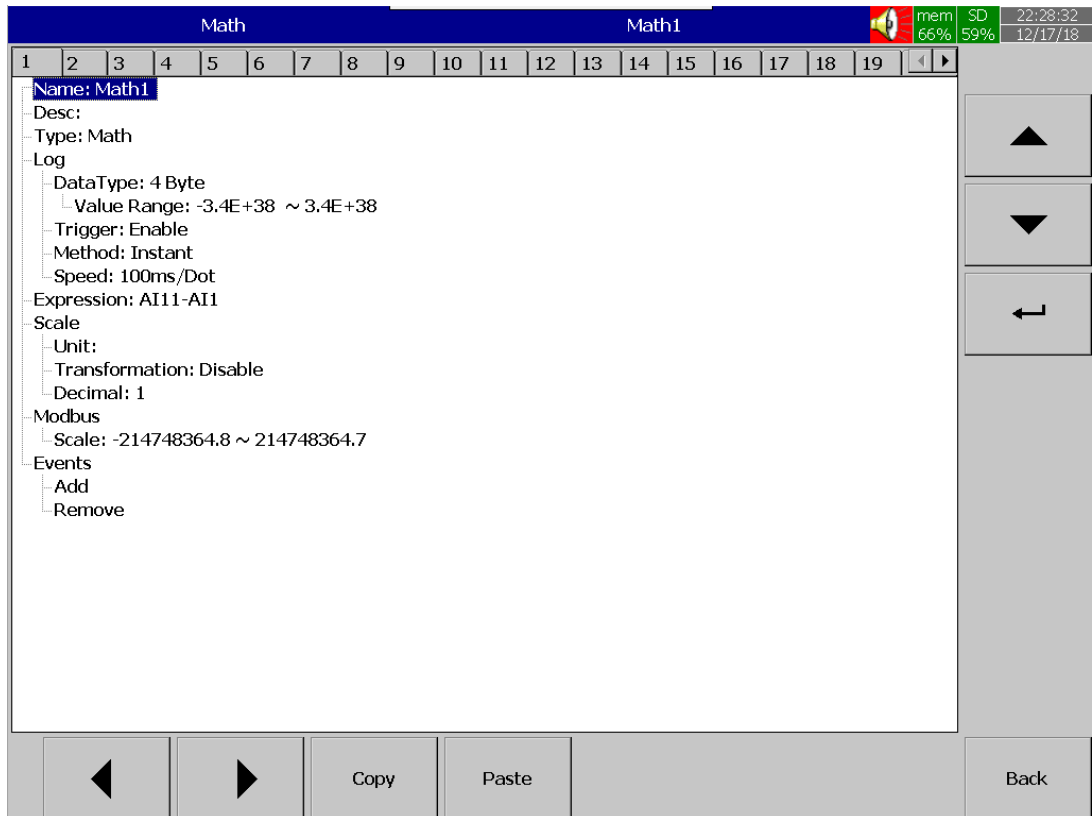

Copy: copy the channel configuration from one channel to another channel.

Paste: Paste the copied configuration to the channel.

Press Copy key in the source channel and press paste key in the destination channel.

5.1.3.1.1 Name

Enables the User to define the name for each channel with a maximum of 18 characters. Select "Name", then Press "Enter", soft key, a keyboard with several keys will appear. Press "Shift" to select special characters. Press "Caps" to select capital letters. Press soft key "OK" after entering a new channel name.

5.1.3.2 Desc

The description about a specific channel on the recorder.

5.1.3.3 Type

The type of math channel. The math channel can be configured as Math, Counter and Totalizer. The options available in type for the user to select are Disable, Math, Counter and Totalizer. The configuration menu will differ depends on the selection of Type.

5.1.3.3.1 Disable

Disable the math channel.

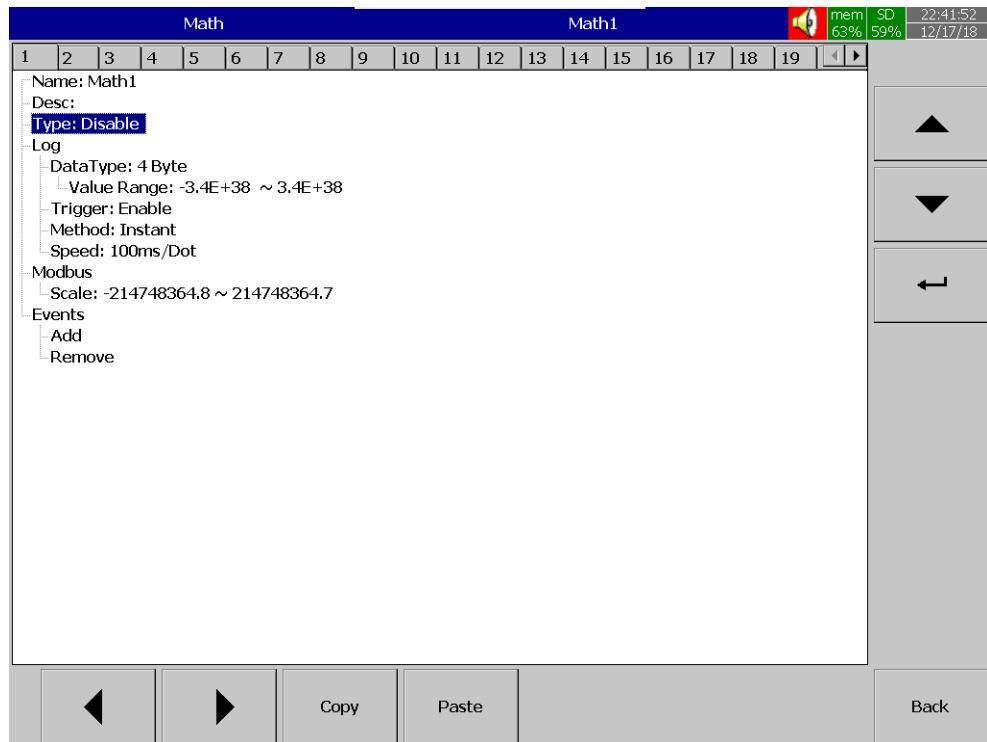

5.1.3.3.2 Math

Configure the channel as Math channel.

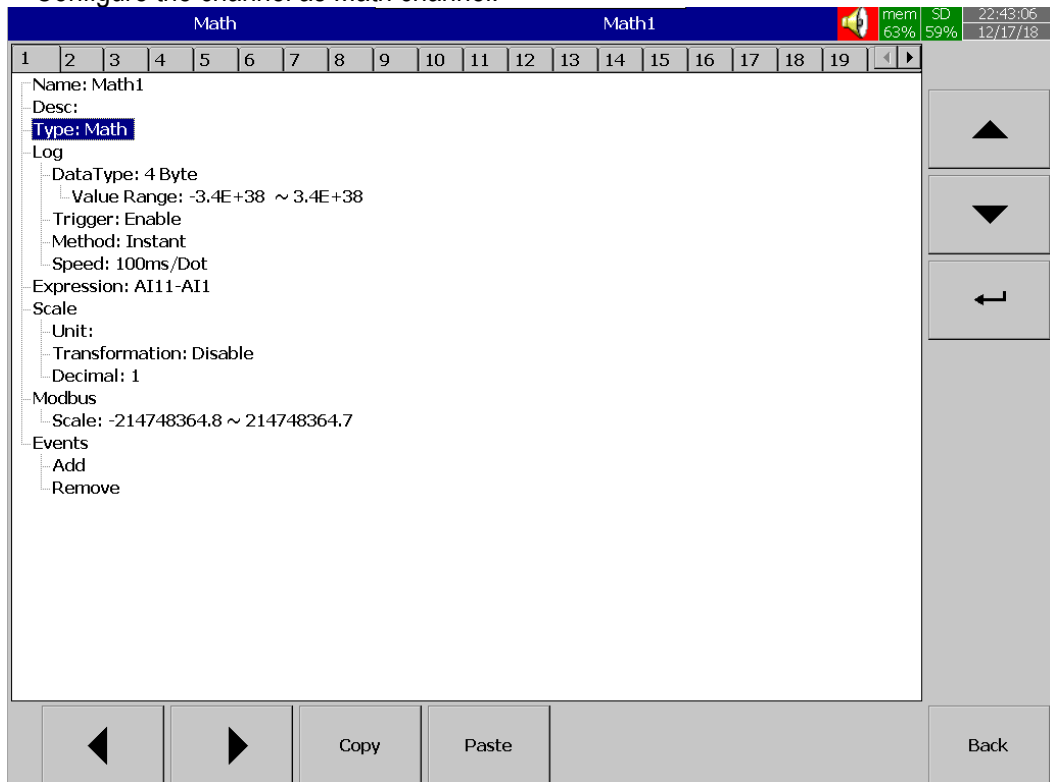

5.1.3.4 Log

5.1.3.4.1 Data Type

The data type for logging is 2 byte or 4 byte
 2 byte range: -32767 to +32767
 4 byte range: -3.4E+38 to +3.4E +38

5.1.3.4.2 Trigger

Two options are available for the user to select.

3. **Disable:** Select disable while the recording of a specific channel is not required at this time
4. **Enable:** Select enable while the recording of a specific channel is required at this time

5.1.3.4.3 Method

This is the method of logging measured data. Select the column **Method** and press **Enter**. Then choose the required Log method from the available methods Instant, Average, Minimum or Maximum of data.

5.1.3.4.3.1 Instant

Logging the last measured data at the logging interval

5.1.3.4.3.2 Average

Logging the averaged of sampled measured data at the logging interval

5.1.3.4.3.3 Minimum

Logging the minimum of sampled measured data at the logging interval

5.1.3.4.3.4 Maximum

Logging the maximum of sampled measured data at the logging interval

5.1.3.4.4 Speed

It is the logging speed (recording speed) of measured data. The available log speeds are as below.

1. 100 msec/dot
2. 1 Sec/dot
3. 2 Sec/dot
4. 5 Sec/dot
5. 10 Sec/dot
6. 15 Sec/dot
7. 20 Sec/dot
8. 30 Sec/dot
9. 1 min/dot
10. 2 min/dot
11. 5 min/dot
12. 15 min/dot
13. 1 hour/dot
14. 2 hour/dot

5.1.3.5 Expression

This will appear only for the channel type as Math. Math channel expression can be configured on this menu. Once the user enter the expression menu the pop up window will show the option for the user to configure the expression. The pop up window consists of Source, Operator and key board.

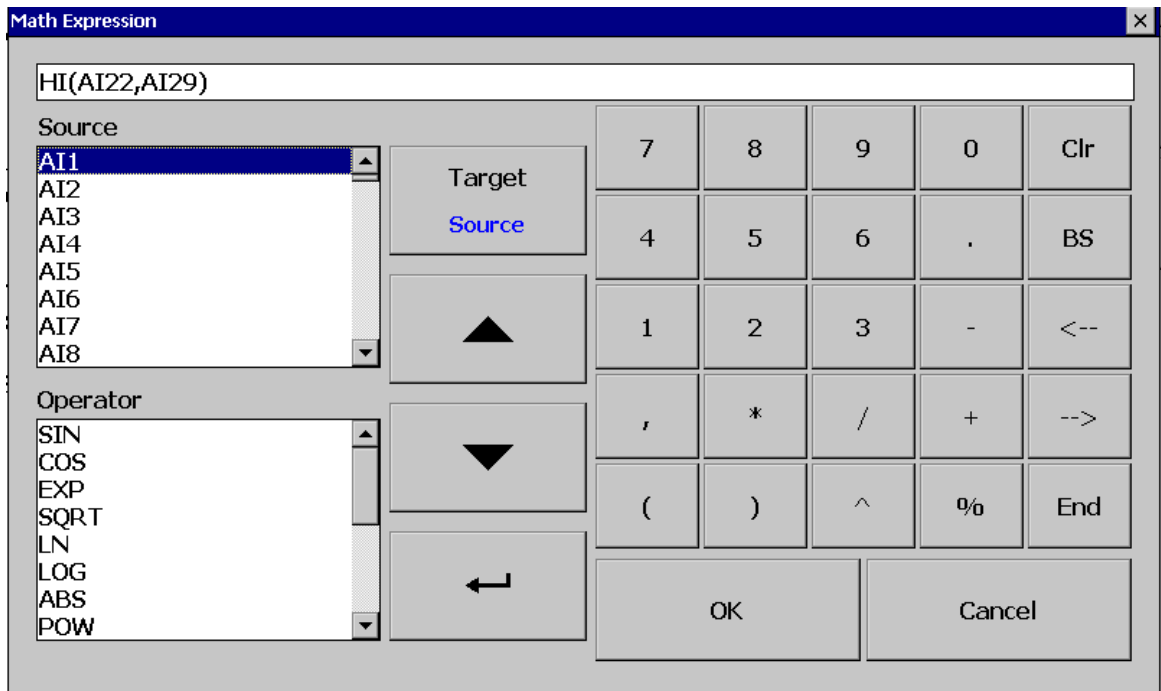

The Source consists of all available Analog inputs, Digital Inputs, Math inputs, external channels. The Operator consists of available mathematical expressions. Use Source, Operator and keyboard to define the Math equation.

5.1.3.5.1 Available Math Expressions

The available math expression for the user to configure the math expressions are as below.

Expressions	Mathematics Functions
+	Addition
-	Subtraction
*	Multiplication
/	Division
SIN(x)	sin(x)
COS(x)	cos(x)
EXP(x)	e^x
SQRT(x)	Square root of x
LN(x)	$\log_e(x)$
LOG(x)	$\log_{10}(x)$
ABS(x)	Absolute of x
POW (x,y)	x^y
ROUND(x)	The closest integral number to x
HI(x,y)	The bigger value between x and y
INV(x)	1/x
TG(x)	tan(x)
CTG(x)	1/tan(x)
ASIN(x)	Sin ⁻¹ (x)
ACOS(x)	Cos ⁻¹ (x)

Expressions	Mathematics Functions
ATG(x)	Tan ⁻¹ (x)
x%y	Remainder of x/y
x^y	x ^y

5.1.3.6 Scale

The scale is used to do scale the math channel value.

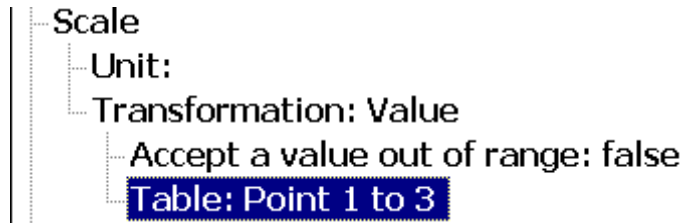

5.1.3.6.1 Unit

The user can define engineering unit for the channel as per the application requirement.

5.1.3.6.2 Transformation

This is mainly used to scale the non-linear process input value. The available options for the user in transformation menu are disable, value and math channel.

5.1.3.6.2.1 Disable

The transformation function is disable

5.1.3.6.2.2 Value

The transformation table will transform the value of the expression to the same math channel.

5.1.3.6.2.3 Math Channel

The transformation table will transform the value of the expression to another math channel.

5.1.3.6.2.3.1 Accept a value out of range

This will allow the user to restrict the maximum value to be displayed as per the value configured in transformation table.

5.1.3.6.2.3.2 Table

The transformation table can be configured with this menu. The user can configure the table with maximum of 64 rows with corresponding input and output values.

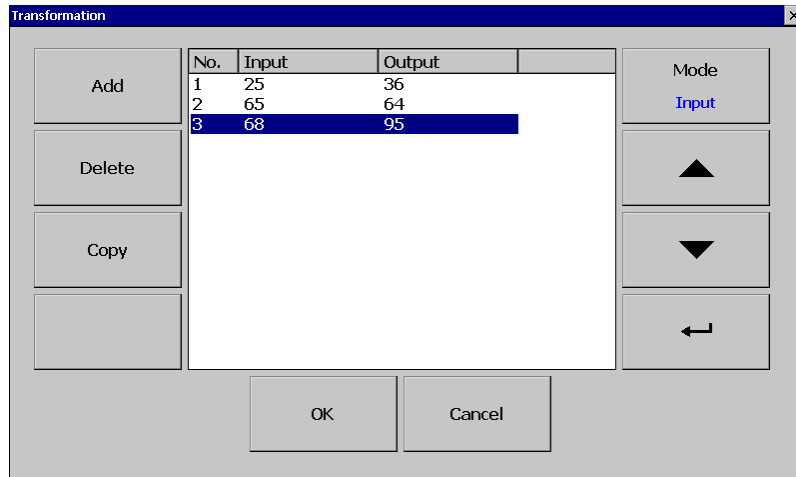

Press "Add" soft key to add a new row into the Transformation table



Press "Delete" soft key to delete existing row from the Transformation table



Press to copy existing row in the Transformation table to create a duplicate entry



Press to toggle between Input and Output entries in the Transformation table



To navigate among rows in the Transformation table



To change the value of the selected rows.

5.1.3.6.3 Counter

Configure the channel as Counter

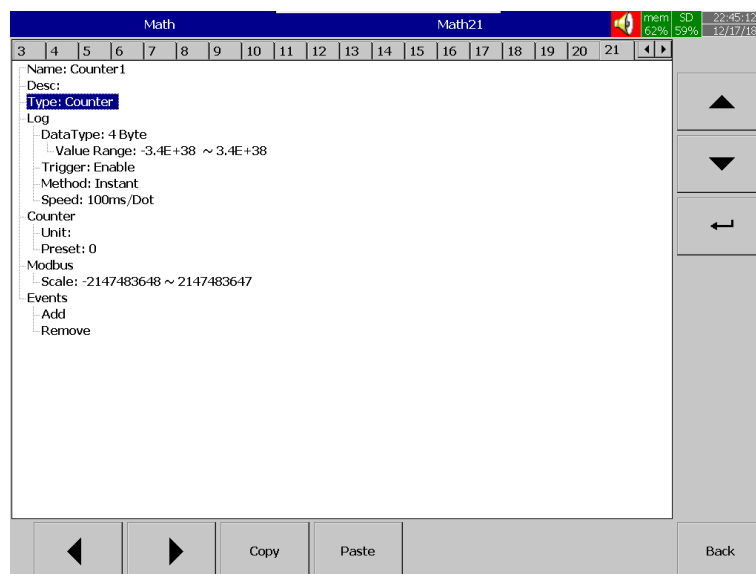

5.1.3.6.3.1 Counter

The counter is used to configure the counter.



5.1.3.6.3.1.1 Unit

Defines the unit of counter

5.1.3.6.3.1.2 Preset

Defines the pre-set value for the counter.

5.1.3.6.4 Totalizer

Configure the channel as totalizer

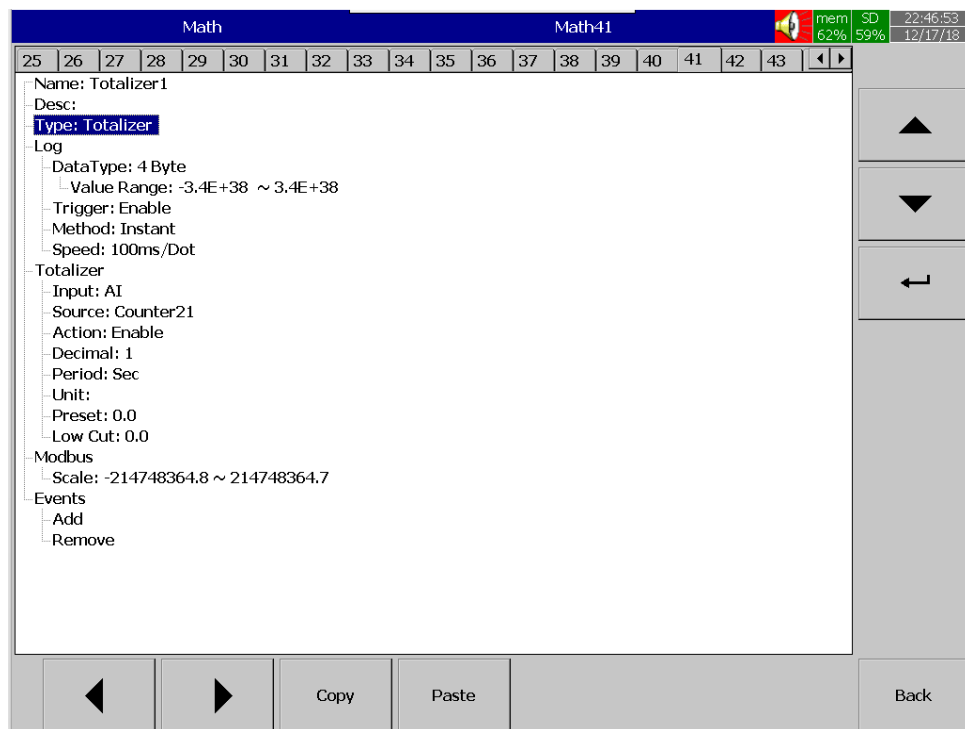

5.1.3.6.4.1 Input

Input type for the Totalizer. Select Analog Input or DI Pulse counter.

5.1.3.6.4.2 Source

Select the source for the Totalizer from Analog input/Math/Counter/Totalizer/DI Pulse counter

5.1.3.6.4.3 Action

Disables or enables the Totalizer

```

Totalizer
├── Input: AI
├── Source: Math1
├── Action: Enable
├── Decimal: 1
├── Period: Sec
├── Unit:
├── Preset: 0.0
├── Low Cut: 0.0

```

5.1.3.6.4.4 Decimal

Defines the decimal point for the Totalizer

5.1.3.6.4.5 Period

Select the period for the totalizer. The available options are Seconds, Minutes, Hours and Days

5.1.3.6.4.6 Unit

Defines the unit of totalizer

5.1.3.6.4.7 Preset

Defines the pre-set value for the Totalizer.

5.1.3.6.4.8 Low Cut

Defines the Low Cut value for the Totalizer. For example If 0.0 is set as Low cut, then, if source channel AI1 is less than 0.0, the Totalizer value will not go to negative.

5.1.3.7 Modbus

The scaling of the channel value in Modbus communication.

5.1.3.8 Events

Events are frequently used for Alarm purposes. The events can be used to operate digital outputs (DO), Timer, Totalizer, Counter or Report. There are maximum five events can be added to each analog input.

Press "Add" to add new event and Press "Remove" to remove selected event

```

Events
├── Add
├── Remove

```

5.1.3.8.1 Type

There are various types of events are available for the user to select for job or alarm purpose. They are listed as below.

5.1.3.8.1.1 H

It is high event. When the process value is higher than high limit, then the alarm or job associated with this event is actuated.

5.1.3.8.1.2 L

It is low event. When the process value is lower than low limit, then the alarm or job associated with this event is actuated.

5.1.3.8.1.3 HH

It is high high event. When the process value is higher than high high limit, then the alarm or job associated with this event is actuated. This is another limit higher than high limit for double warning.

5.1.3.8.1.4 LL

It is low low event. When the process value is lower than low low limit, then the alarm or job associated with this event is actuated. This is another limit lower than low limit for double warning.

5.1.3.8.1.5 Dev+

It is deviation + event. This event will be triggered on the positive deviation of process value. The job or alarm is activated when the process value is deviated by the value higher than set point from the previous process value.

5.1.3.8.1.6 Dev-

It is deviation - event. This event will be triggered on the negative deviation of process value. The job or alarm is activated when the process value is deviated by the value lower than set point from the previous process value.

5.1.3.8.1.7 Error

It is error event. This event will be activated when there is an error on the input of the channel.

5.1.3.8.2 Set point

Set point for the event.

5.1.3.8.2.1 Hysteresis

To avoid the alarm or event been activated too often, Hysteresis value can be defined for the event trigger set point.

5.1.3.8.2.2 Holding time

To avoid the alarm or event been activated too often, the holding time can be defined for the event trigger set point. In process sometimes SP is reached but it will go down immediately, this might due to process instability. To avoid these kind of nuisance situations, the holding time can be used to see that PV stays at above that SP more than the holding time and then only activate the action for that event. The range of holding time can be set from 1 min to 60 min.

5.1.3.8.3 Log

The event can be logged as alarm or event. They can be selected from the available options. They are as below.

5.1.3.8.3.1 Log Alarm

Log the event as Alarm.

5.1.3.8.3.2 Log Alarm (Auto Ack)

Log the event as alarms and acknowledge automatically

5.1.3.8.3 Log Event

Log as event

5.1.3.8.4 Job1 & Job2

The job is called as a task to be performed when the event is activated. There are two jobs Job1 and Job2 can be added to perform in any event.

A typical example is to trigger **an alarm buzzer** in the event of a high temperature. Each channel can accept five different types of events (or alarms) and each event can create two jobs. Please note that a job under Event is different from a job perform by **Operate** key. The job is actuated by an event, and the Operate is actuated by manual control, no event necessary.

Note: Please refer to the section [Jobs](#) for full details about various jobs available

5.1.3.9 Examples for Math Channel Application

5.1.3.9.1 Example 1 with Transformation Table

A chemical tank has a non-linear shape. The level is 0 to 1400 cms. The Recorder should display 0 to 170 Tons as per following table

No.	Input	Output
1	0	0
2	200	10
3	400	30
4	600	80
5	800	130
6	1000	150
7	1200	160
8	1400	170

5.1.3.9.2 Example 2 with Transformation Table

The input of 0 to 20mA for pressure 0 to 150 PSIG is required to display as per the below table.

No.	Input	Output
1	50.0	34
2	60.0	43
3	70.0	53
4	80.0	64
5	90.0	76
6	100.0	87
7	110.0	100
8	120.0	113
9	130.0	127

The below steps are required to follow.

1. Configure the AI Channel as per the input configuration.



2. Configure one math channel with the required conversion using transformation table.

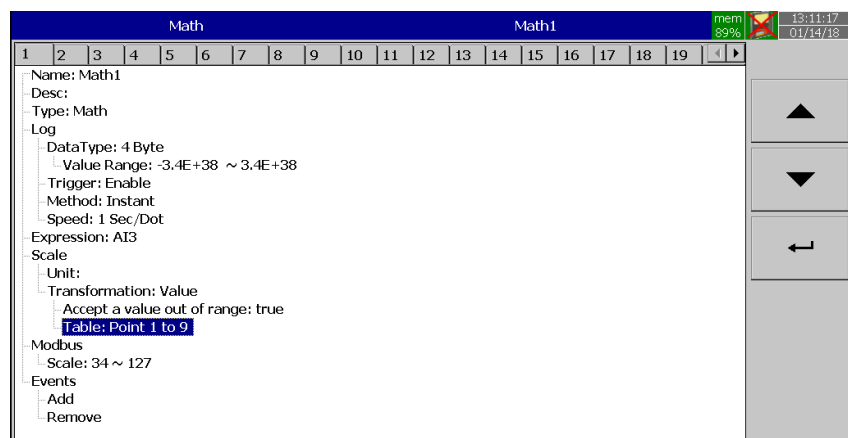

3. Configure the Expression with the input channel
4. Add the Transformation table type as values
5. Create the transformation table with the known values.

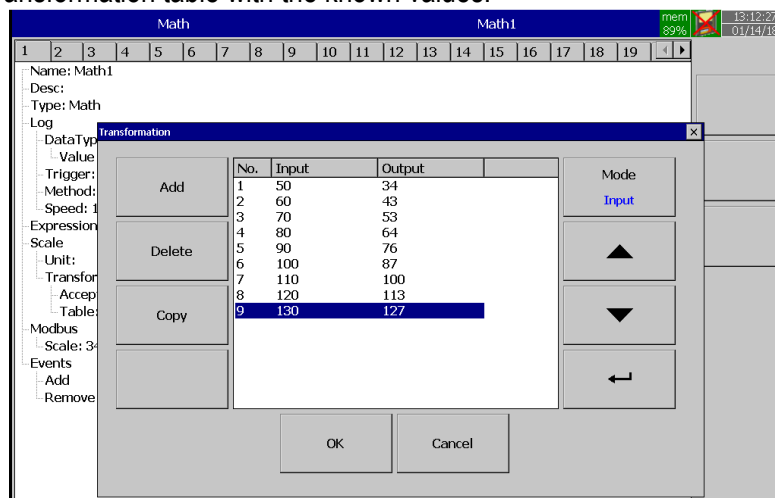

6. Now the Math channel will show the value as per the table.

5.1.3.9.3 Relative Humidity Application

The relative humidity can be calculated using Math Channel application. For this we need two analog inputs with RTD input to measure dry bulb temperature and wet bulb temperature. For this example the recorder has two analog inputs with RTD input in AI1 to measure dry bulb temperature and AI2 to measure wet bulb temperature. The below are steps to be followed to calculate the relative humidity.

The relative humidity can be calculated by using the below formulae.

The formulae can be split in to 3 different parts for easier understanding.

1. Calculate E_d with dry-bulb (T_d) and wet-bulb (T_w) temperatures using the following equation.

$$E_d = 6.112 \cdot e^{\left(\frac{17.502T_d}{240.97+T_d}\right)}$$

2. Calculate E_w with dry-bulb (T_d) and wet-bulb (T_w) temperatures using the following equation.

$$E_w = 6.112 \cdot e^{\left(\frac{17.502T_w}{240.97+T_w}\right)}$$

In the above equations the temperatures units are °C.

3. Calculate Relative Humidity(RH) using the following equation

The units of relative humidity are in %

Example:

Assume that dry-bulb temperature (T_d) = 20°C and wet-bulb temperature (T_w) = 15°C.

$$E_d = 6.112 \cdot e^{\left(\frac{17.502 \cdot 20}{240.97+20}\right)}$$

$$E_d = 6.112 \cdot e^{\left(\frac{350.04}{260.97}\right)}$$

$$E_d = 6.112 \cdot e^{(1.3413)}$$

$$E_d = 6.112 \cdot 3.8240$$

$$E_d = 23.372$$

$$E_w = 6.112 \cdot e^{\left(\frac{17.502 \cdot 15}{240.97+15}\right)}$$

$$E_w = 6.112 \cdot e^{\left(\frac{262.53}{255.97}\right)}$$

$$E_w = 6.112 \cdot e^{(1.0256)}$$

$$E_w = 6.112 \cdot 2.7888$$

$$E_w = 17.045$$

$$RH = 58.376\%$$

3 Math channels are required to calculate one RH.

Td = AI1, analog input for dry bulb temperature (PT100)

Tw = AI2, analog input for wet bulb temperature (PT100)

$$\text{Math1} = E_d = 6.112 \cdot \text{EXP}((17.502 \cdot \text{AI1}) / (240.97 + \text{AI1}))$$

$$\text{Math2} = E_w = 6.112 \cdot \text{EXP}((17.502 \cdot \text{AI2}) / (240.97 + \text{AI2}))$$

$$\text{Math3} = RH = (\text{Math2} - (0.66875 \cdot (1 + 0.00115 \cdot \text{AI2}) \cdot (\text{AI1} - \text{AI2}))) / \text{Math1} \cdot 100$$

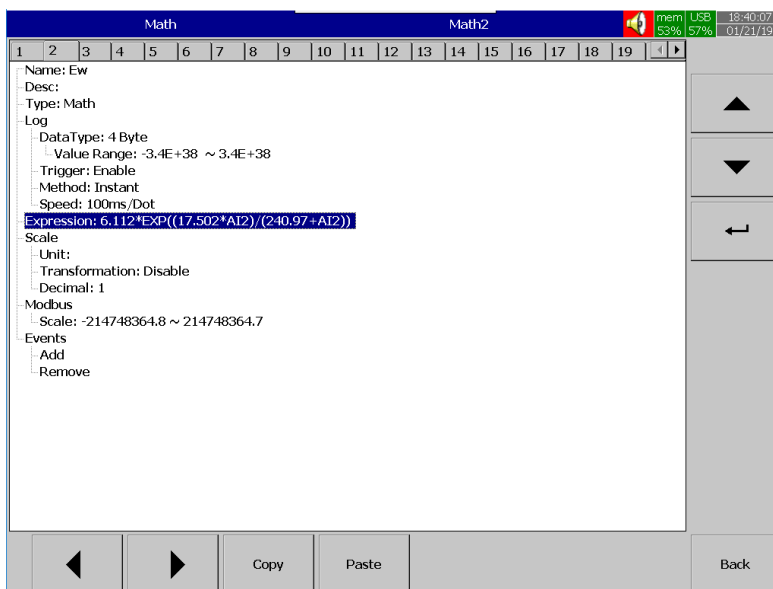
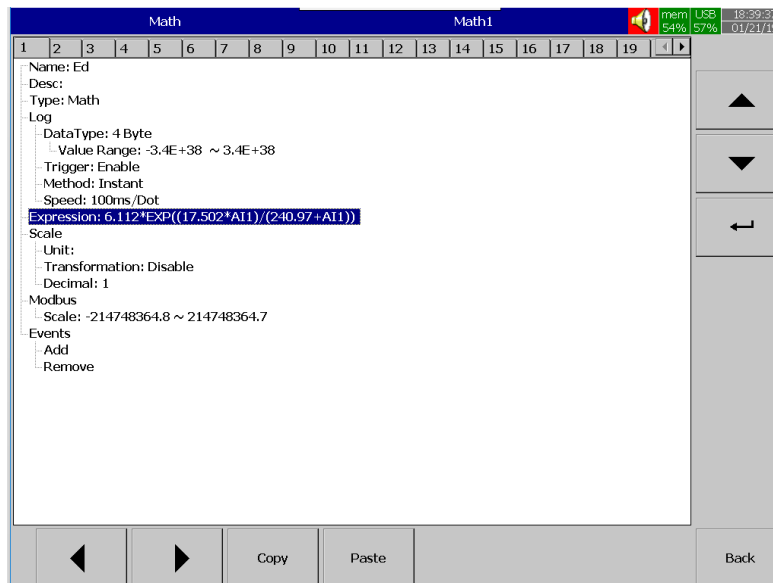

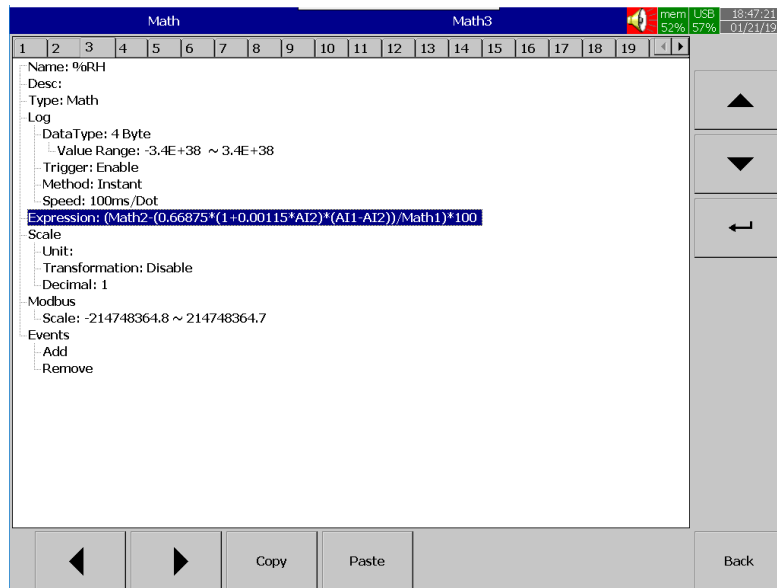

Now Math3 will display Relative humidity in %

Math channels are virtual channels. They contain measured values based on equations. These values can be recorded similar to physically connected Analog inputs and display as digital values, trends, bar graphs etc.

5.1.3.9.4 Counter Example

The user requires the number of occurrences of an event in a day. The pressure switch in DI1 goes logic high is consider as an event in this application. The Pressure switch is connected in DI1. The High signal indicates the high pressure.

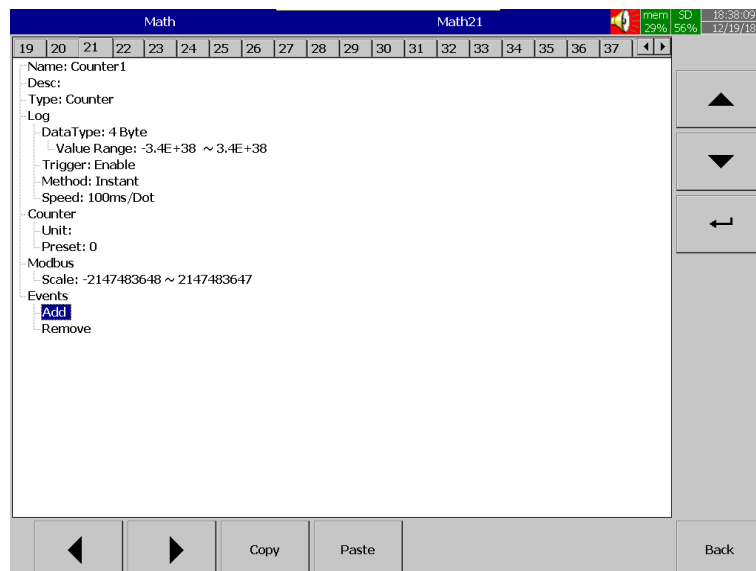

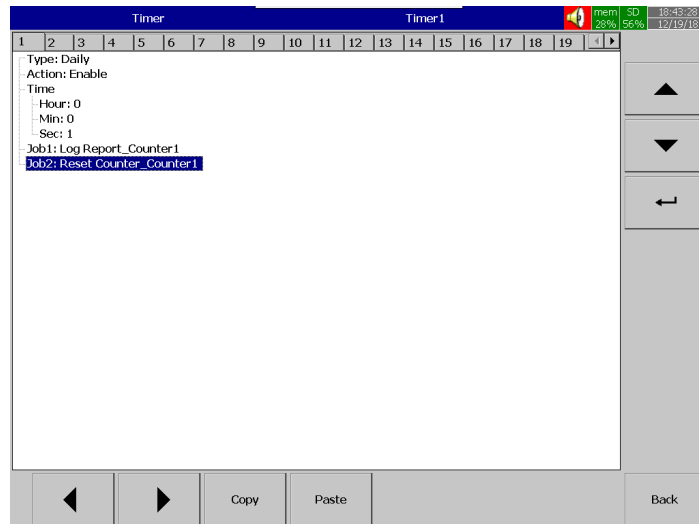
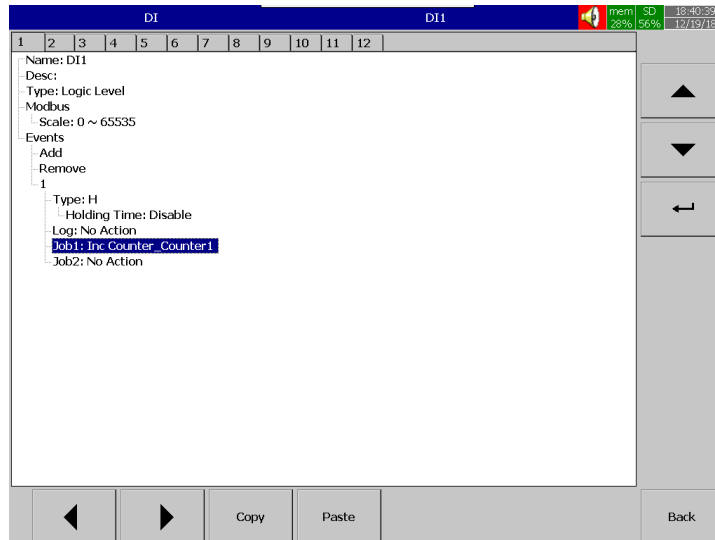

The counter value will be logged in the report and reset to start the count of next day. The Historical report can be viewed in Event mode Report tab with the selection of Daily mode.

5.1.3.9.5 Totalizer Example

Water flow rate is in M³/Sec. The user needs to know about total water discharged and daily reports

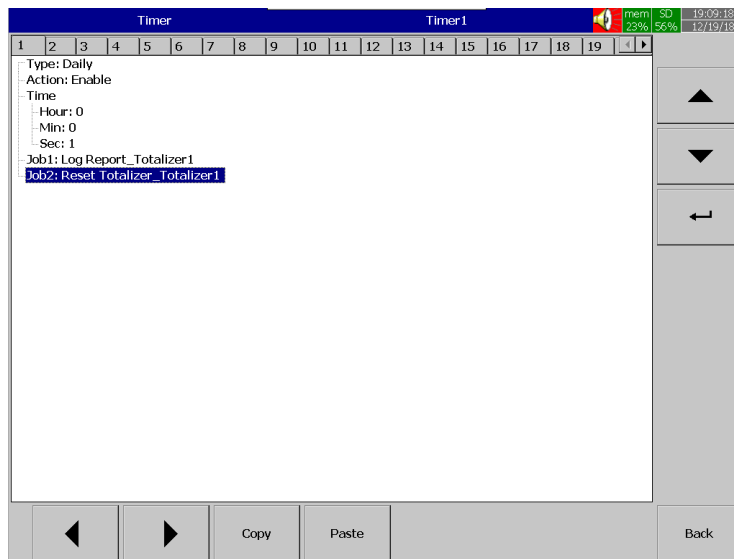
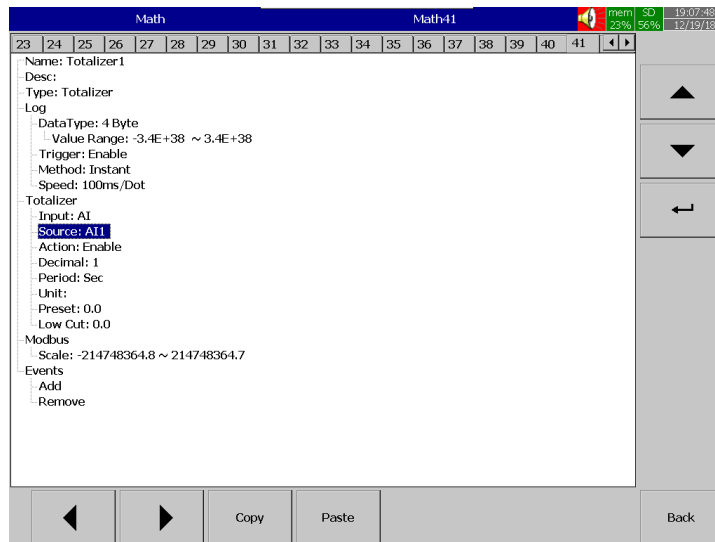





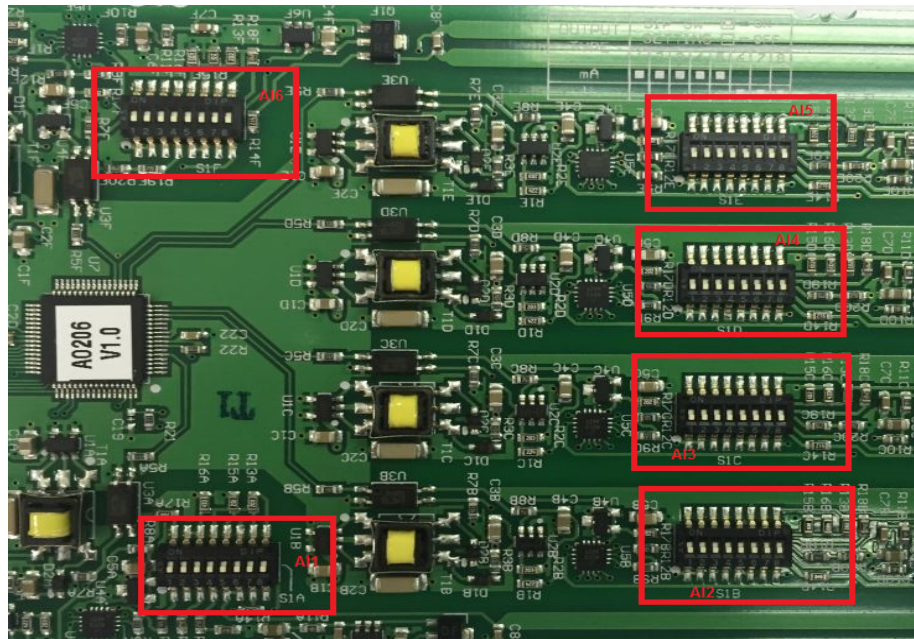

The Totalizer value will be logged in the report and reset to start the totalizer of next day. The Historical report can be viewed in Event mode Report tab with the selection of Daily mode. The Weekly and monthly report can also be viewed by changing the mode.

5.1.4 Analog Output

The Analog Output card dip switches needs to be set for required output type. The default setting set to Voltage Output. For Current Output Set Dip Switches 1 to 5 to ON and 6 to 8 to OFF. The below figure shows the Dip Switches setting on the AO Card.



After entering the Configuration menu, in the Channel, select AO then Press the “Enter” soft key to get into AO Channel configuration menu. . It displays the AO channel AO1 as the first AO channel configuration page. Press directional navigation keys   at the bottom to select other channels. Press directional keys   on the right hand side to select the column. After completing Configuration, press  soft key, then press  soft key to return to main display. All configurations will be saved automatically.

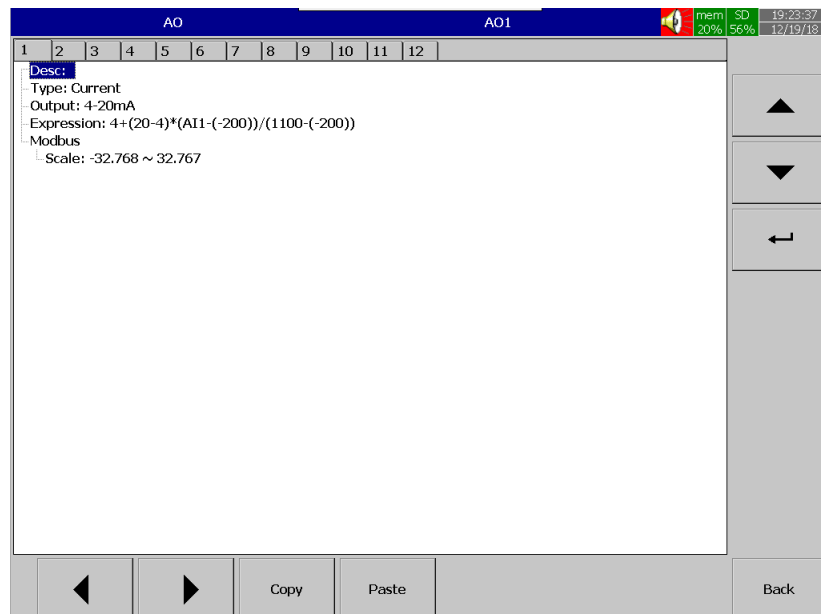

Copy: copy the channel configuration from one channel to another channel.

Paste: Paste the copied configuration to the channel.

Press Copy key in the source channel and press paste key in the destination channel.

5.1.4.1 Desc

The description about a specific channel on the recorder.

5.1.4.2 Type

The type of analog output channel. The analog output channel can be configured as Voltage or Current. The output menu will differ depends on the selection of Type.

5.1.4.3 Output

Select the required output. The available options are Disable, 0 to 20mA and 4 to 20mA for current output and Disable, 0 to 5V, 1 to 5V and 0 to 10V for Voltage output

5.1.4.4 Expression

The expression required for retransmission. Once the user enter the expression menu the pop up window will show the option for the user to configure the expression. The pop up window consists of Source, Operator and key board.

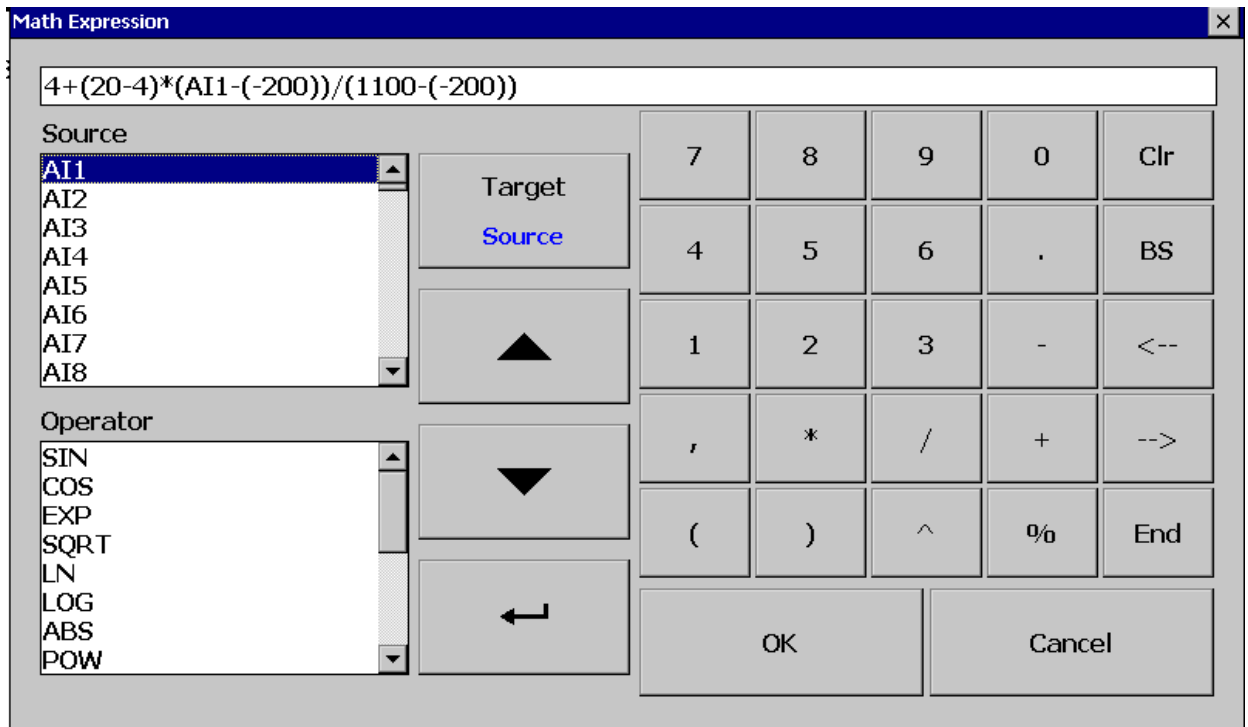

The Source consists of all available Analog inputs, Digital Inputs, Math inputs, external channels. The Operator consists of available mathematical expressions. Use Source, Operator and keyboard to define the Math equation.

5.1.4.4.1 Available Math Expressions

The available math expression for the user to configure the math expressions are as below.

Expressions	Mathematics Functions
+	Addition
-	Subtraction
*	Multiplication
/	Division
SIN(x)	sin(x)

Expressions	Mathematics Functions
COS(x)	cos(x)
EXP(x)	e ^x
SQRT(x)	Square root of x
LN(x)	log _e (x)
LOG(x)	log ₁₀ (x)
ABS(x)	Absolute of x
POW (x,y)	x ^y
ROUND(x)	The closest integral number to x
HI(x,y)	The bigger value between x and y
INV(x)	1/x
TG(x)	tan(x)
CTG(x)	1/tan(x)
ASIN(x)	Sin ⁻¹ (x)
ACOS(x)	Cos ⁻¹ (x)
ATG(x)	Tan ⁻¹ (x)
x%y	Remainder of x/y
x^y	x ^y

The analog output expression should follow the below syntax for the expression.

$$\text{Minimum Output} + \frac{[(\text{Maximum Output} - \text{Minimum Output}) * (\text{Input} - \text{Input Low Scale})]}{\text{Input High Scale} - \text{Input Low Scale}}$$

For example AO1 is required to retransmit current output 4 to 20mA corresponds to AI1 scaled with -120°C to 1000°C should have the expression as below.

$$4 + (20-4) * (AI1 - (-120)) / (1000 - (-120))$$



5.1.4.5 Modbus



The scaling of the channel value in Modbus communication.

5.1.5 Digital Output

After entering the Configuration menu, in the Channel, select DO then Press the “Enter” soft key to get into DO Channel configuration menu. It displays the DO channel **DO1** as the first DO channel

configuration page. Press directional navigation keys   at the bottom to select other

channels. Press directional keys   on the right hand side to select the column. After

completing Configuration, press  soft key, then press  soft key to return to main display. All configurations will be saved automatically.

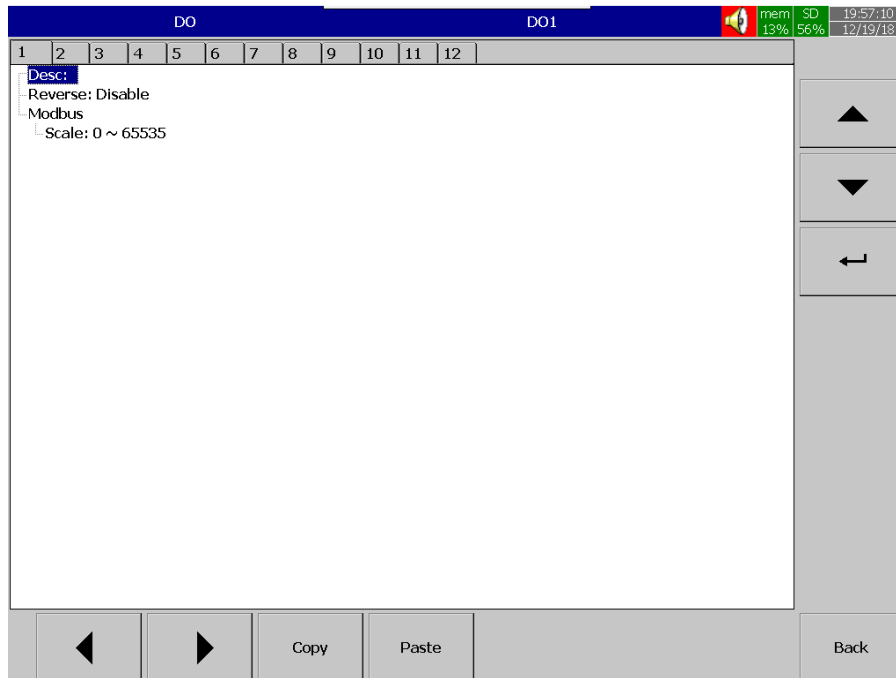

Copy: copy the channel configuration from one channel to another channel.

Paste: Paste the copied configuration to the channel.

Press Copy key in the source channel and press paste key in the destination channel.

5.1.5.1 Desc

The description about a specific channel on the recorder.

5.1.5.2 Reverse

The Reverse option is Enable or Disable. If it is enabled then the output state of DO will be reversed.

For example, when reverse is disabled, the relay output is Normally Open (NO). If the application requires that the output should be Normally Closed (NC) relay at Recorder, then enable "Reverse" for the selected Digital Output. The Relay output will be normally closed.



5.1.6 External

The external channel is used to read the data from external devices with Modbus communication. In this the recorder will be act as a Master and read the data from Modbus slaves. The data will be logged and displayed by using External channels. The no of available External channels will be varied depends on the recorder model. The available External channel on the different recorder models as below.

PR Recorder	PPS-1000	PPS-2000	PPS-3000
No of External Channels	24	48	96

After entering the Configuration menu, in the Channel, select External then Press the "Enter" soft key to get into External Channel configuration menu. It displays the External channel **External 1** as the first External channel configuration page. Press directional navigation keys  at the

bottom to select other channels. Press directional keys  on the right hand side to select

the column. After completing Configuration, press  soft key, then press  soft key to return to main display. All configurations will be saved automatically.

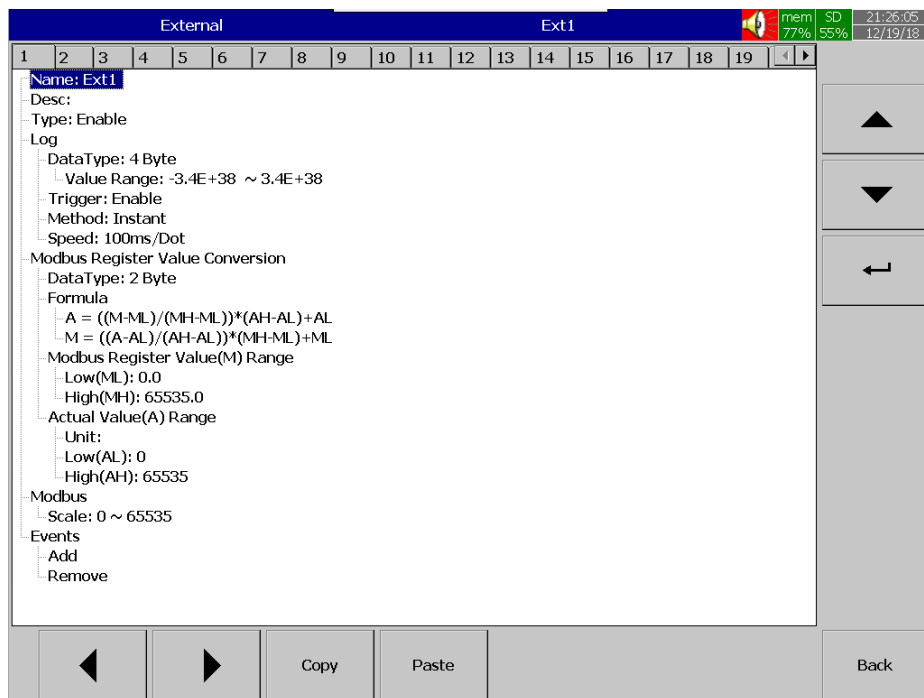

Copy: copy the channel configuration from one channel to another channel.

Paste: Paste the copied configuration to the channel.

Press Copy key in the source channel and press paste key in the destination channel.

5.1.6.1 Name

Enables the User to define the name for each channel with a maximum of 18 characters. Select "Name", then Press "Enter", soft key, a keyboard with several keys will appear. Press "Shift" to select special characters. Press "Caps" to select capital letters. Press soft key "OK" after entering a new channel name.

5.1.6.2 Desc

The description about a specific channel on the recorder.

5.1.6.3 Type

Option available to enable or disable the channel

5.1.6.4 Log

5.1.6.4.1 Data Type

The data type for logging is 2 byte.
2 byte range: -32767 to +32767

5.1.6.4.2 Trigger

Two options are available for the user to select.

1. **Disable:** Select disable while the recording of a specific channel is not required at this time
2. **Enable:** Select enable while the recording of a specific channel is required at this time

5.1.6.4.3 Method

This is the method of logging measured data. Select the column **Method** and press **Enter**. Then choose the required Log method from the available methods Instant, Average, Minimum or Maximum of data.

5.1.6.4.3.1 Instant

Logging the last measured data at the logging interval

5.1.6.4.3.2 Average

Logging the averaged of sampled measured data at the logging interval

5.1.6.4.3.3 Minimum

Logging the minimum of sampled measured data at the logging interval

5.1.6.4.3.4 Maximum

Logging the maximum of sampled measured data at the logging interval

5.1.6.4.4 Speed

It is the logging speed (recording speed) of measured data. The available log speeds are as below.

1. 100 msec/dot
2. 1 Sec/dot
3. 2 Sec/dot
4. 5 Sec/dot
5. 10 Sec/dot
6. 15 Sec/dot
7. 20 Sec/dot
8. 30 Sec/dot
9. 1 min/dot
10. 2 min/dot
11. 5 min/dot
12. 15 min/dot
13. 1 hour/dot
14. 2 hour/dot

5.1.6.5 Modbus Register Value Conversion

5.1.6.5.1 Data Type

The data type for logging is 2 byte or 4 byte

2 byte range: 0 to 65535

4 byte range: 0 to 4294967295

5.1.6.5.2 Modbus Register Value Range (M)

The user can configure the Modbus data range low (ML) and high (MH) according to the device connected.

5.1.6.5.3 Actual Value Range (M)

The user can configure the Engineering unit, Actual value range low (AL) and Actual value range high (AH) as per the device.

5.1.6.6 Modbus

The scaling of the channel value in Modbus communication.

5.1.6.7 Events

Events are frequently used for Alarm purposes. The events can be used to operate digital outputs (DO), Timer, Totalizer, Counter or Report. There are maximum five events can be added to each analog input.

Press "Add" to add new event and Press "Remove" to remove selected event



5.1.6.7.1 Type

There are various types of events are available for the user to select for job or alarm purpose. They are listed as below.

5.1.6.7.1.1 H

It is high event. When the process value is higher than high limit, then the alarm or job associated with this event is actuated.

5.1.6.7.1.2 L

It is low event. When the process value is lower than low limit, then the alarm or job associated with this event is actuated.

5.1.6.7.1.3 HH

It is high high event. When the process value is higher than high high limit, then the alarm or job associated with this event is actuated. This is another limit higher than high limit for double warning.

5.1.6.7.1.4 LL

It is low low event. When the process value is lower than low low limit, then the alarm or job associated with this event is actuated. This is another limit lower than low limit for double warning.

5.1.6.7.1.5 Dev+

It is deviation+ event. This event will be triggered on the positive deviation of process value. The job or alarm is activated when the process value is deviated by the value higher than set point from the previous process value.

For example,

Set point = 10

At 10.00.01 Hrs, Tag1 = 40

At 10.00.02 Hrs, Tag1 = 51 Then, job or alarm is activated

5.1.6.7.1.6 Dev-

It is deviation- event. This event will be triggered on the negative deviation of process value. The job or alarm is activated when the process value is deviated by the value lower than set point from the previous process value.

For example,

Set point = 10

At 10.00.01 Hrs, Tag1 = 40

At 10.00.02 Hrs, Tag1 = 29 Then, job or alarm is activated.

5.1.6.7.1.7 Error

It is error event. This event will be activated when there is an error on the input of the channel.

5.1.6.7.2 Set point

Set point for the event.

5.1.6.7.2.1 Hysteresis

To avoid the alarm or event been activated too often, Hysteresis value can be defined for the event trigger set point.

5.1.6.7.2.2 Holding time

To avoid the alarm or event been activated too often, the holding time can be defined for the event trigger set point. In process sometimes SP is reached but it will go down immediately, this might due to process instability. To avoid these kind of nuisance situations, the holding time can be used to see that PV stays at above that SP more than the holding time and then only activate the action for that event. The range of holding time can be set from 1 min to 60 min.

5.1.6.7.3 Log

The event can be logged as alarm or event. They can be selected from the available options. They are as below.

5.1.6.7.3.1 Log Alarm

Log the event as Alarm.

5.1.6.7.3.2 Log Alarm (Auto Ack)

Log the event as alarms and acknowledge automatically

5.1.6.7.3.3 Log Event

Log as event

5.1.6.7.4 Job1 & Job2

The job is called as a task to be performed when the event is activated. There are two jobs Job1 and Job2 can be added to perform in any event.



A typical example is to trigger **an alarm buzzer** in the event of a high temperature. Each channel can accept five different types of events (or alarms) and each event can create two jobs. Please note that a job under Event is different from a job perform by **Operate** key. The job is actuated by an event, and the Operate is actuated by manual control, no event necessary.

Note: Please refer to the section [Jobs](#) for full details about various jobs available and section [communication](#) for more details about External Channel.

5.2 Controller

This will allow the user to configure the PID process control card. The maximum no of PID Process control cards will vary depends on the recorder model as described below

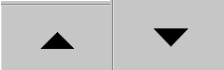
PR Recorder	PPS-1000	PPS-2000	PPS-3000
No of PID Process control card	4	4	8

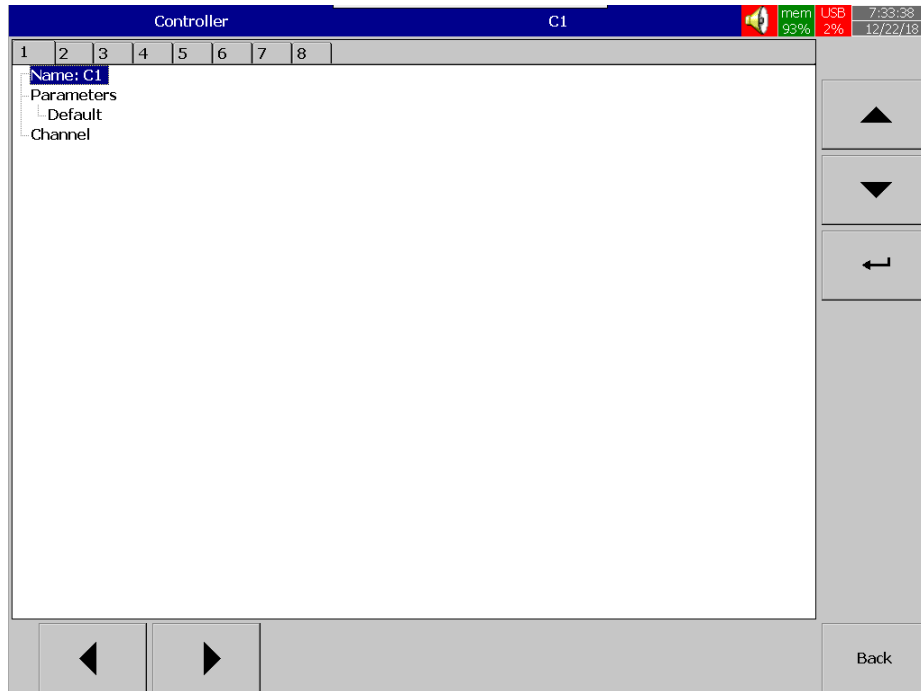

After entering the Configuration menu, in the Channel, select Controller then Press the “Enter” soft key to get into Controller Channel configuration menu. It displays the Controller channel **C1** as the first Controller channel configuration page. Press directional navigation keys  at the bottom to select other channels. Press directional keys  on the right hand side to select the column. After completing Configuration, press  soft key, then press  soft key to return to main display. All configurations will be saved automatically.



5.2.1 Name

Enables the User to define the name for each channel with a maximum of 18 characters. Select “Name”, then Press “Enter”, soft key, a keyboard with several keys will appear. Press “Shift” to select special characters. Press “Caps” to select capital letters. Press soft key “OK” after entering a new channel name.

5.2.2 Parameter

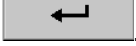
This will allow the user to configure the PID Control function on the Process Control Card. Press **Parameter** and then press  **Enter** Soft key to access the parameter configuration table. In the Configuration table the user can edit the parameters of the Process Control Card as per their requirement by selecting the desired parameter using the UP DOWN keys  and then press the Enter Soft Key . The Enter Soft key will be disabled for the restricted parameters.

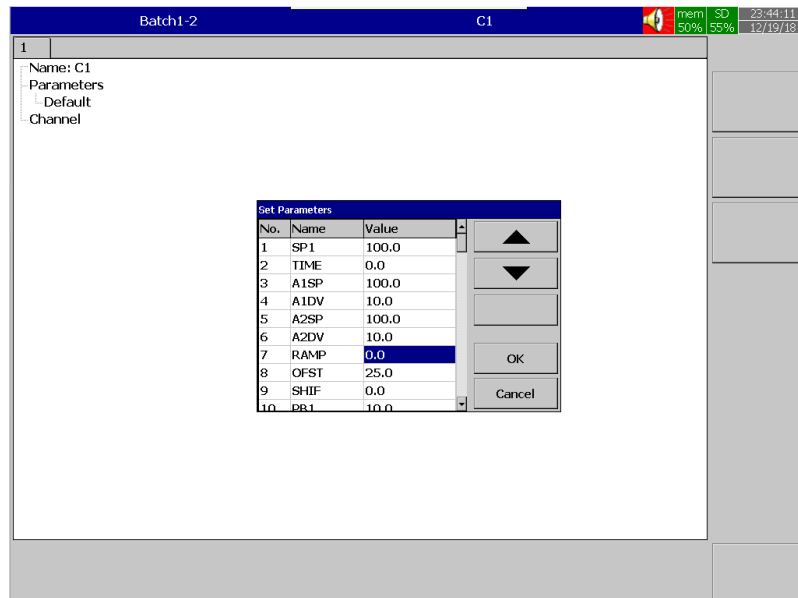
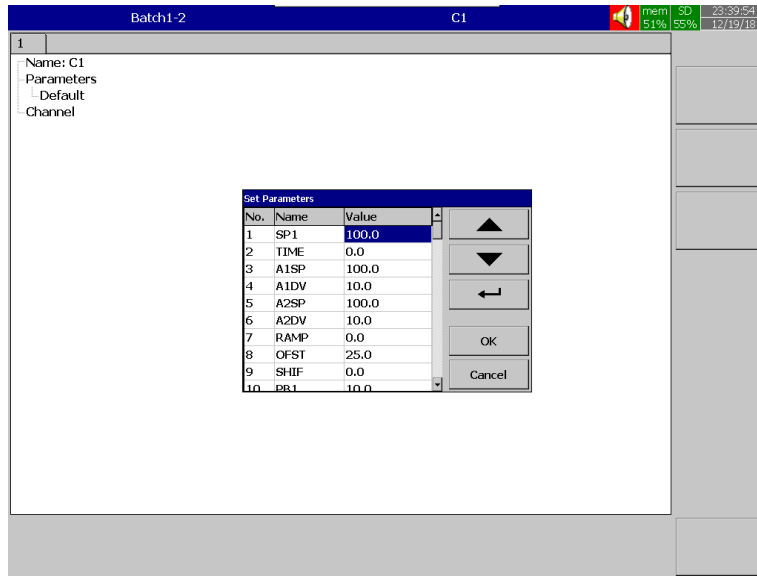

5.2.2.1 Parameter Configuration

The below table will explain the available parameters and their functions.

Parameter Notation	Parameter Description	Range Low* B	Range High* B	Default Value* C	Unit* E
SP1	Set point 1	SP1L	SP1H	100.0°C (212.0°F)	PV
TIME	Dwell Time	0	6553.5	0.0	Minute
A1SP	Alarm 1 Set point	* B1	* B1	100.0°C (212.0°F)	* E1
A1DV	Alarm 1 Deviation Value	-200.0°C (-360.0°F)	200.0°C (360.0°F)	10.0°C (18.0°F)	* E1
A2SP	Alarm 2 Set point	* B1	* B1	100.0°C (212.0°F)	* E2
A2DV	Alarm 2 Deviation Value	-200.0°C (-360.0°F)	200.0°C (360.0°F)	10.0°C (18.0°F)	* E2
RAMP	Ramp Rate	0	500.0°C (900.0°F)	0.0	* E3

Parameter Notation	Parameter Description	Range Low*B	Range High*B	Default Value*C	Unit*E
OFST	Offset Value for P control	0	100.0	25.0	%
REFC	Reference Constant for Specific Function	0	60	2	
SHIF	PV1 Shift (offset) Value	-200.0°C (-360.0°F)	200.0°C (360.0°F)	0.0	PV1
PB1	Proportional Band 1 Value	0	500.0°C (900.0°F)	10.0°C (18.0°F)	PV
TI1	Integral Time 1 Value	0	1000	100	Sec
TD1	Derivative Time 1 Value	0	360.0	25.0	Sec
CPB	Cooling Proportional Band Value	1	255	100	% of PB
DB	Heating-Cooling Dead Band	-36.0	36.0	0	% of PB
SP2	Set point 2	*B2	*B2	37.8°C (100.0°F)	PV
PB2	Proportional Band 2 Value	0	500.0°C (900.0°F)	10.0°C (18.0°F)	PV
TI2	Integral Time 2 Value	0	1000	100	Sec
TD2	Derivative Time 2 Value	0	360.0	25.0	Sec
O1HY	Output1 ON-OFF Control Hysteresis	0.1	55.6°C (100.0°F)	0.1	PV
A1HY	Hysteresis Control of Alarm1	0.1	10.0°C (18.0°F)	0.1	*E1
A2HY	Hysteresis Control of Alarm2	0.1	10.0°C (18.0°F)	0.1	*E2
PL1	Output 1 Power Limit	0	100	100	%
PL2	Output 2 Power Limit	0	100	100	%
FUNC	Function Complexity Level	0 *B3	1 *B3	1	
COMM	Communication Interface Type	0 *B4	8 *B4	1	
PROT	COMM Protocol Selection	0 *B5	0 *B5	0	
ADDR	Address Assignment of Digital COMM	1	255		
BAUD	Baud Rate of Digital COMM	0 *B7	9 *B7	5	
DATA	Data Bit count of Digital COMM	0 *B8	1 *B8	1	
PARI	Parity Bit of Digital COMM	0 *B9	2 *B9	0	
STOP	Stop Bit Count of Digital COMM	0 *B10	1 *B9	0	
AOFN	Analog Output Function	0 *B11	7 *B11	0	
IN1	IN1 Sensor Type Selection	0 *B12	17 *B12	1 (0)	
IN1U	IN1 Unit Selection	0 *B13	2 *B13	0 (1)	
DP1	IN1 Decimal Point Selection	0 *B14	3 *B14	1	
IN1L	IN1 Low Scale Value	-19999	45536	0	*E5
IN1H	IN1 High Scale Value	-19999	45536	1000	*E5
SP1L	SP1 Low Scale Value	-19999	45536	0.0°C (32.0°F)	PV
SP1H	SP1 High Scale Value	-19999	45536	1000.0°C (1832.0°F)	PV

Parameter Notation	Parameter Description	Range Low*B	Range High*B	Default Value*C	Unit*E
IN2	IN2 Signal Type Selection	0*B13	20*B15	1	
IN2U	IN2 Unit Selection	0*B13	2*B13	2	
DP2	IN2 Decimal Point Selection	0*B14	3*B14	1	
IN2L	IN2 Low Scale Value	-19999	45536	0	*E6
IN2H	IN2 High Scale Value	-19999	45536	1000	*E6
EIFN	Event Input Function	0*B16	9*B16	1	
OUT1	Output 1 Function	0*B17	1*B17	0	
O1TY	Output 1 Signal Type	0*B18	8*B18	0	
CYC1	Output 1 Cycle Time	0.1	100.0	18.0	Sec
O1FT	Output 1 Failure Transfer Mode	0*B18	0*B18	-0.1	%
OUT2	Output 2 Function	0*B18	0*B18	0	
O2TY	Output 2 Signal Type	0*B18	0*B18	0	
CYC2	Output 2 Cycle Time	0.1	100.0	18.0	Sec
O2FT	Output 2 Failure Transfer Mode	-0.1 *B19	100.0*B19	-0.1	%
A1FN	Alarm 1 Function	0*B22	15*B22	2	
A1MD	Alarm 1 Operation Mode	0*B23	3*B23	0	
A1FT	Alarm 1 Failure Transfer Mode	0*B24	1*B24	1	
A2FN	Alarm 2 Function	0*B22	15*B22	2	
A2MD	Alarm 2 Operation Mode	0*B23	3*B23	0	
A2FT	Alarm 2 Failure Transfer Mode	0*B24	1*B24	1	
SELF	Self-Tune Function Selection	0*B25	1*B25	0	
SLEP	Sleep mode Function Selection	0*B26	1*B26	0	
PVMD	PV Mode Selection	0*B27	3*B27	0	
SP2F	Format of Set point 2 Value	0*B28	1*B28	0	
FILT	Filter Damping Time Constant of PV	0*B29	9*B29	2	
SPMD	Set point Mode Selection	0*B30	5*B30	0	
SEL1	Select 1'st Parameter	0*B31	18*B31	0	
SEL2	Select 2'nd Parameter	0*B31	18*B31	0	
SEL3	Select 3'rd Parameter	0*B31	18*B31	0	
SEL4	Select 4'th Parameter	0*B31	18*B31	0	
SEL5	Select 5'th Parameter	0*B31	18*B31	0	
DRIF	Warm-up Drift Calibration Factor	-5.0°C	5.0°C		°C
AD0	A to D Zero Calibration Coefficient	-360	360		
ADG	A to D Gain Calibration Coefficient	-199.9	199.9		
V1G	Voltage Input1 Gain Calibration Coefficient	-199.9	199.9		
CJTL	Cold Junction Low Temperature Calibration Coefficient	-5.0°C	40.0°C		°C

Parameter Notation	Parameter Description	Range Low*B	Range High*B	Default Value*C	Unit*E
CJG	Cold Junction Gain Calibration Coefficient	-199.9	199.9		
REF1	Reference Voltage1 Calibration Coefficient for RTD1	-199.9	199.9		
SR1	Serial Resistance 1 Calibration Coefficient for RTD1	-199.9	199.9		
MA1G	mA input 1 Gain Calibration Coefficient	-199.9	199.9		
REF2	Reference Voltage2 Calibration Coefficient for RTD2	-199.9	199.9		
SR2	Serial Resistance 2 Calibration Coefficient for RTD2	-199.9	199.9		
V2G	Voltage input 2 Gain Calibration Coefficient	-199.9	199.9		
MA2G	mA input 2 Gain Calibration Coefficient	-199.9	199.9		
O2L	Output2 Low Calibration Coefficient	0	360.0		
O2H	Output 2 High Calibration Coefficient	0	900.0		
SIG1	Point 1 Signal Value of Special Sensor	-19999	45536		
IND1	Point 1 Indication Value of Special Sensor	-19999	45536		PV
SIG2	Point 2 Signal Value of Special Sensor	-19999	45536		
IND2	Point 2 Indication Value of Special Sensor	-19999	45536		PV
SIG3	Point 3 Signal Value of Special Sensor	-19999	45536		
IND3	Point 3 Indication Value of Special Sensor	-19999	45536		PV
SIG4	Point 4 Signal Value of Special Sensor	-19999	45536		
IND4	Point 4 Indication Value of Special Sensor	-19999	45536		PV
SIG5	Point 5 Signal Value of Special Sensor	-19999	45536		
IND5	Point 5 Indication Value of Special Sensor	-19999	45536		PV
SIG6	Point 6 Signal Value of Special Sensor	-19999	45536		
IND6	Point 6 Indication Value of Special Sensor	-19999	45536		PV
SIG7	Point 7 Signal Value of Special Sensor	-19999	45536		
IND7	Point 7 Indication Value of Special Sensor	-19999	45536		PV

Parameter Notation	Parameter Description	Range Low*B	Range High*B	Default Value*C	Unit*E
SIG8	Point 8 Signal Value of Special Sensor	-19999	45536		
IND8	Point 8 Indication Value of Special Sensor	-19999	45536		PV
SIG9	Point 9 Signal Value of Special Sensor	-19999	45536		
IND9	Point 9 Indication Value of Special Sensor	-19999	45536		PV
TYPE	Signal Type of Special Sensor	0	3		
DATE	Manufacturing Date of Product	0	3719		
NO	Serial Number of Product	1	999		
HOUR	Working Hour Value	0	65535		Hour
HRLO	Fractional Hour Value	0	0.9		0.1Hour
ERR1	Historical Error Record 1	0	FFFF	0	
ERR2	Historical Error Record 2	0	FFFF	0	
DELI	ASCII Input Delimiter	0000	007F	000A	
BPL1	OUT1 Bumpless Transfer Value	0	100.00		%
BPL2	OUT2 Bumpless Transfer Value	0	100.00		%
PVHI	Historical Maximum Value of PV	-19999	45536		PV
PVLO	Historical Minimum Value of PV	-19999	45536		PV
CJCL	Sense Voltage of Cold Junction Calibration Low	31.680	40.320		mV
FILE	Default File Selection	0 *B32	1 *B32		
PV	Current Process Value	-19999	45536		PV
SV	Current set point Value	-19999	45536		PV
MV1	Current Output 1 Value	0	100.00		%
MV2	Current Output 2 Value	0	100.00		%
ALM	Contains Conditional Code of parameters Resolution and Current Alarm Status	0 *B33	EF7F *B33		
DV	Current Deviation (PV-SV)Value	-12600	12600		PV
PV1	IN1 Process Value	-19999	45536		*E5
PV2	IN2 Process Value	-19999	45536		*E6
PB	Current Proportional Band Value	0	500.0°C (900.0°F)		PV
TI	Current Integral Time Value	0	4000		Sec
TD	Current Derivative Time Value	0	1440		Sec
EROR	Current Error Code	0 *B34	40 *B34		

Parameter Notation	Parameter Description	Range Low*B	Range High*B	Default Value*C	Unit*E
PROG	Program Identification Code Contains Program Number and Version Number	0 *B35	15.99 *B35		
MODE	Contains Lockout Status code and Current system mode	0 *B36	3.5 *B34		
CMND	Command Password	0	65535		
JOB	Job Password	0	65535		
CJCT	Cold Junction Compensation Temperature	-40.0°C	90.0°C		°C
PVR	Current Process Rate Value	-16383	16383		PV/min
PVRH	Maximum Process Rate Value	-16383	16383		PV/min
PVRL	Minimum Process Rate Value	-16383	16383		PV/min
SPC	Current Target Value of set point	-19999	45536		PV

Notes

*B: The ranges of some parameters are dependent on the input types. The range of IN1 and IN2 for various input type is shown in the following table

Input Type	Range Low	Rang High
J_T/C	-120°C(-184°F)	1000°C(1832°F)
K_T/C	-200°C(-328°F)	1370°C(2498°F)
T_T/C	-250°C(-418°F)	400°C(752°F)
E_T/C	-100°C(-148°F)	900°C(1652°F)
B_T/C	0°C(32°F)	1820°C(3308°F)
R_T/C	0°C(32°F)	1767.8°C(3214°F)
S_T/C	0°C(32°F)	1767.8°C(3214°F)
N_T/C	-250°C(-418°F)	1300°C(2372°F)
L_T/C	-200°C(-328°F)	900°C(1652°F)
PT100_DN	-210°C(-346°F)	700°C(1292°F)
PT100_JS	-210°C(-346°F)	600°C(1112°F)
CT	0 Amps	90 Amps
Linear (mA or Voltage)	-19999	45536

5-1 PID Process Control Card Input Types

*B1: Range for A1SP & A2SP

If A1FN=	Range of A1SP same as range of
PV1.H, PV1.L	IN1
PV2.H, PV2.L	IN2
P1.2 H, P1.2 L, D1.2 H , D1.2 L	IN1, IN2

5-2 A1SP Range

If A2FN=	Range of A2SP same as range of
PV1.H,PV1.L	IN1
PV2.H,PV2.L	IN2
P1.2 H, P1.2 L, D1.2 H , D1.2 L	IN1, IN2

5-3 A2SP Range

*B2: Range for SP2

If PVMD=	Range of SP2 same as range of
PV1	IN1
PV2	IN2
P1-2, P2-1	IN1, IN2

5-4 Range of SP2

*B3: Display Symbol and Description of FUNC

Parameter Value	Display Symbol	Description
0	BASC	Basic Function Mode
1	FULL	Full Function Mode

5-5 Mode Selection

*B4: Display Symbol and Description for COMM

Parameter Value	Display Symbol	Description
0	NONE	No Communication Function
1	485	RS-485 Interface
2	232	RS-232 Interface
3	4-20	4-20mA Analog Retransmission Output
4	0-20	0-20mA Analog Retransmission Output
5	0-1V	0-1V Analog Retransmission Output
6	0-5V	0-5V Analog Retransmission Output
7	1-5V	1-5V Analog Retransmission Output
8	0-10V	0-10V Analog Retransmission Output

5-6 Communication Mode

*B5: Display Symbol and Description for PROT

Parameter Value	Display Symbol	Description
0	RTU	Modbus RTU Mode
1	ASCI	Modbus ASCII Mode
2	DNET	DeviceNet Protocol
3	PBUS	Profibus Protocol
4	FBUS	Fieldbus Protocol
5	ABUS	Reserved
6	BNET	Reserved

5-7 Communication Protocol

*B7: Display Symbol and Description for BAUD

Parameter Value	Display Symbol	Description
0	0.3	0.3 Kbits/Second Baud Rate
1	0.6	0.6 Kbits/Second Baud Rate
2	1.2	1.2 Kbits/Second Baud Rate
3	2.4	2.4 Kbits/Second Baud Rate
4	4.8	4.8 Kbits/Second Baud Rate
5	9.6	9.6 Kbits/Second Baud Rate
6	14.4	14.4 Kbits/Second Baud Rate
7	19.2	19.2 Kbits/Second Baud Rate

Parameter Value	Display Symbol	Description
8	28.8	28.8 Kbits/Second Baud Rate
9	38.4	38.4 Kbits/Second Baud Rate

5-8 Communication Baud Rate

*B8: Display Symbol and Description for DATA

Parameter Value	Display Symbol	Description
0	7 BIT	7 Data Bits
1	8 BIT	8 Data Bits

5-9 Communication Data Length

*B9: Display Symbol and Description for PARI

Parameter Value	Display Symbol	Description
0	EVEN	Even Parity
1	ODD	Odd Parity
2	NONE	No Parity

5-10 Communication Parity

*B10: Display Symbol and Description for STOP

Parameter Value	Display Symbol	Description
0	1 BIT	One Stop Bit
1	2 BIT	Two Stop Bits

5-11 Communication Stop Bit

*B11: Display Symbol and Description for AOFN

Parameter Value	Display Symbol	Description
0	PV1	Retransmit IN1 Process Value
1	PV2	Retransmit IN2 Process Value
2	P1-2	Retransmit IN1-IN2 Difference Process Value
3	P2-1	Retransmit IN2-IN1 Difference Process Value
4	SV	Retransmit Set Point Value
5	MV1	Retransmit Output1 manipulation Value
6	MV2	Retransmit Output2 manipulation Value
7	DV	Retransmit Deviation (PV-SV) Value

5-12 AOFN Function

*B12: Display Symbol and Description for IN1

Parameter Value	Display Symbol	Description
0	J_TC	J Type Thermocouple
1	K_TC	K Type Thermocouple
2	T_TC	T Type Thermocouple
3	E_TC	T Type Thermocouple
4	B_TC	B Type Thermocouple
5	R_TC	R Type Thermocouple
6	S_TC	S Type Thermocouple
7	N_TC	N Type Thermocouple
8	L_TC	L Type Thermocouple
9	PT.DN	PT 100 Ohms DIN Curve
10	PT.JS	PT100 Ohms JIS Curve
11	4-20	4-20mA Linear Current Input
12	0-20	0-20mA Linear Current Input
13	0-1V	0-1V Linear Voltage Input
14	0-5V	0-5V Linear Voltage Input
15	1-5V	1-5V Linear Voltage Input
16	0-10	0-10V Linear Voltage Input
17	SPEC	Special defined sensor Curve

5-13 IN1 Type

*B13: Display Symbol and Description for IN1U & IN2U

Parameter Value	Display Symbol	Description
0	°C	Degree Celsius Unit
1	°F	Degree Fahrenheit Unit
2	PU	Process Unit

5-14 Display Unit for IN1 & IN2

*B14: Display Symbol and Description for DP1 & DP2

Parameter Value	Display Symbol	Description
0	NO-DP	No Decimal Digit
1	1-DP	One Decimal Digit
2	2-DP	Two Decimal Digits
3	3-DP	Three Decimal Digits

5-15 Decimal Digit for DP1 & DP2

*B15: Display Symbol and Description for IN2

Parameter Value	Display Symbol	Description
0	NONE	IN2 No Function
1	CT	Current Transformer Input
2	4-20	4-20mA Linear Current Input
3	0-20	0-20mA Linear Current Input
4	0-1V	0-1V Linear Voltage Input
5	0-5V	0-5V Linear Voltage Input
6	1-5V	1-5V Linear Voltage Input
7	0-10	0-10V Linear Voltage Input

5-16 IN2 Input

*B16: Display Symbol and Description for EIFN

Parameter Value	Display Symbol	Description
0	NONE	Event Input No Function
1	SP2	SP2 Activated to replace SP1
2	PID2	PB2, TI2, TD2 Activated to replace PB1, TI1, TD1
3	SP.P2	SP2, PB2, TI2, TD2 Activated to replace SP1, PB1, TI1, TD1
4	RS.A1	Reset Alarm 1 Output
5	RS.A2	Reset Alarm 2 Output
6	R.A1.2	Reset Alarm 1 & Alarm 2 Output
7	D.O1	Disable Output 1
8	D.O2	Disable Output 2
9	D.O1.2	Disable Output 1 & Output 2
10	LOCK	Lock All Parameters

5-17 EIFN Function

*B17: Display Symbol and Description for OUT1

Parameter Value	Display Symbol	Description
0	REVR	Reverse (Heating) Control Action
1	DIRT	Direct (Cooling) Control Action

5-18 Out1 Action

*B18: Display Symbol and Description for O1TY & O2TY

Parameter Value	Display Symbol	Description
0	RELY	Relay Output
1	SSRD	Solid State Relay Drive Output
2	SSR	Solid State Relay Output
3	4-20	4-20mA Current Module
4	0-20	0-20mA Current Module

Parameter Value	Display Symbol	Description
5	0-1V	0-1V Voltage Module
6	0-5V	0-5V Voltage Module
7	1-5V	1-5V Voltage Module
8	0-10	0-10V Voltage Module

5-19 Out1 & Out2 Type

***B19:** Failure transfer mode for output 1 and output 2, select BPLS (Bumpless transfer) or 0.0 ~ 100.0 % to continue output 1 and output 2 control function as the unit fails, power starts or manual mode starts.

***B20:** Display Symbol and Description for OUT2

Parameter Value	Display Symbol	Description
0	NONE	Output 2 no function
1	COOL	PID cooling control
3	DCPS	DC power supply module installed

5-20 Out2 Function

***B21:** Display Symbol and Description for DISF

Parameter Value	Display Symbol	Description
0	PV	Display PV Value
1	SV	Display SV Value

5-21 Display Function

***B22:** Display Symbol and Description for A1FN & A2FN

Parameter Value	Display Symbol	Description
0	NONE	No alarm function
1	TIMR	Dwell timer action
2	DE.HI	Deviation high alarm
3	DE.LO	Deviation low alarm
4	DB.HI	Deviation band out of band alarm
5	DB.LO	Deviation band in band alarm
6	PV1.H	IN1 process value high alarm
7	PV1.L	IN1 process value low alarm
8	PV2.H	IN2 process value high alarm
9	PV2.L	IN2 process value low alarm
10	P1.2.H	IN1 or IN2 process value high alarm
11	P1.2.L	IN1 or IN2 process value low alarm
12	D1.2.H	IN1 IN2 difference process value high alarm
13	D1.2.L	IN1 IN2 difference process value low alarm
14	LB	Loop break alarm
15	SEN.B	Sensor break or A-D fails

5-22 Alarm1 & Alarm2 Function

***B23:** Display Symbol and Description for A1MD & A2MD

Parameter Value	Display Symbol	Description
0	NORM	Normal alarm action
1	LTCH	Latching alarm action
2	HOLD	Hold alarm action
3	LT.HO	Latching & Hold action

5-23 Alarm1 & Alarm2 Operation Mode

***B24:** Display Symbol and Description for A1FT & A2 FT

Parameter Value	Display Symbol	Description
0	OFF	Alarm Output OFF as unit Fails
1	ON	Alarm Output ON as unit Fails

5-24 Alarm1 & Alarm2 Failure transfer mode

***B25:** Display Symbol and Description for SFLF

Parameter Value	Display Symbol	Description
0	NONE	Auto tuning (Self Tune) Function disabled
1	YES	Auto tuning (Self Tune) Function Enabled

5-25 Self Tuning

***B26:** Display Symbol and Description for SLEP

Parameter Value	Display Symbol	Description
0	NONE	Sleep Mode Function disabled
1	YES	Sleep Mode Function Enabled

5-26 Sleep Mode

***B27:** Display Symbol and Description for PVMD

Parameter Value	Display Symbol	Description
0	PV1	Use PV1 as Process Value
1	PV2	Use PV2 as Process Value
2	P1-2	Use PV1-PV2 Difference as Process Value
3	P2-1	Use PV2-PV1 Difference as Process Value

5-27 PV Mode Selection

***B28:** Display Symbol and Description for SP2F

Parameter Value	Display Symbol	Description
0	ACTU	Setpoint2 (SP2) is an Actual Value
1	DEVI	Setpoint2 (SP2) is a Deviation Value

5-28 SP2 Set Point format

***B29:** Display Symbol and Description for FILT

Parameter Value	Display Symbol	Description
0	0	0 second time constant
1	0.2	0.2 second time constant
2	0.5	0.5 second time constant
3	1	1 second time constant
4	2	2 seconds time constant
5	5	5 seconds time constant
6	10	10 seconds time constant
7	20	20 seconds time constant
8	30	30 seconds time constant
9	60	60 seconds time constant

5-29 Filter Damping Time Constant for PV

***B30:** Display Symbol and Description for SPMD

Parameter Value	Display Symbol	Description
0	SP1.2	Use SP1 or SP2 (depends on EIFN) as set point
1	MIN.R	Use minute ramp rate as set point
2	HR.R	Use hour ramp rate as set point
3	PV1	Use IN1 process value as set point
4	PV2	Use IN2 process value as set point
5	PUMP	Selected for pump control

***B31:** Display Symbol and Description for SEL1-SEL5

Parameter Value	Display Symbol	Description
0	NONE	No parameter put ahead
1	TIME	Parameter TIME put ahead
2	A1.SP	Parameter A1SP put ahead
3	A1.DV	Parameter A1DV put ahead
4	A2.SP	Parameter A2SP put ahead
5	A2.DV	Parameter A2DV put ahead

Parameter Value	Display Symbol	Description
6	RAMP	Parameter RAMP put ahead
7	OFST	Parameter OFST put ahead
8	REFC	Parameter REFC put ahead
9	SHIF	Parameter SHIF put ahead
10	PB1	Parameter PB1 put ahead
11	TI1	Parameter TI1 put ahead
12	TD1	Parameter TD1 put ahead
13	C.PB	Parameter CPB put ahead
14	DB	Parameter DB put ahead
15	SP2	Parameter SP2 put ahead
16	PB2	Parameter PB2 put ahead
17	TI2	Parameter TI2 put ahead
18	TD2	Parameter TD2 put ahead

5-30 SEL Selection

*B32: Display Symbol and Description for FILE

Parameter Value	Display Symbol	Description
0	0	Perform Default Setting by using °C File
1	1	Perform Default Setting by using °F File

5-31 Default File Selection

*B33: Description of Alarm Value

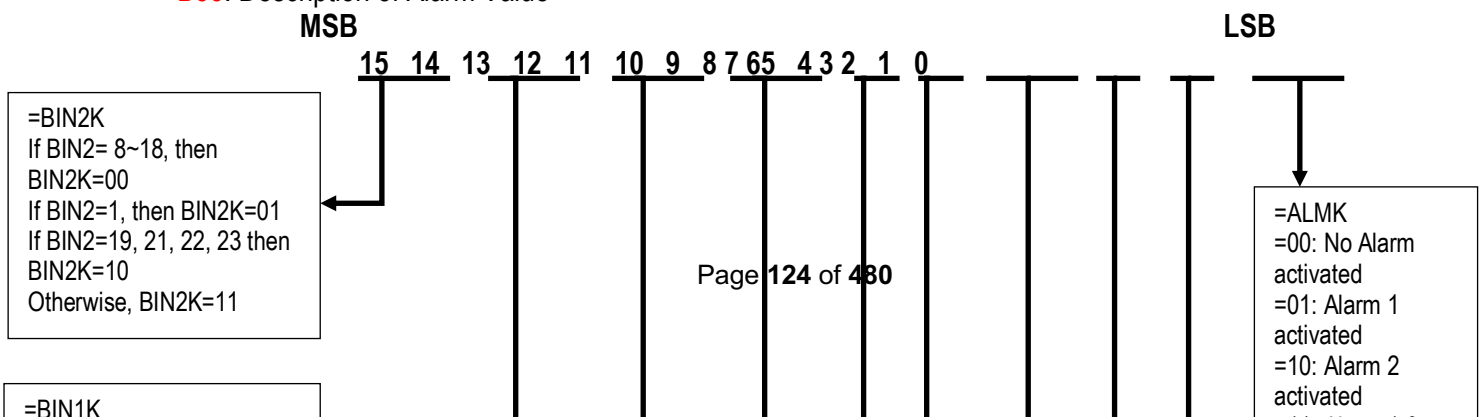

***B34: Error Messages**

Error Code	Display Symbol	Error Description	Corrective Action
1	Er 01	Illegal setup values used: PV1 is used for both PVMD and SPMD that is meaningless for control.	Check and correct setup values of PVMD and SPMD, PV and SV can't use the same value for normal control
2	Er 02	Illegal setup values used: PV2 is used for both PVMD and SPMD that is meaningless for control	Same as error code1
3	Er 03	Illegal setup values used: P1-2 or P2-1 is used for PVMD while PV1 or PV2 is used for SPMD. Dependent values are used for PV and SV will produce incorrect result of control	Check and correct setup values of PVMD and SPMD. Difference of PV1 and PV2 can't be used for PV while PV1 or PV2 is used for SV
4	Er 04	Illegal setup values used: COOL is used for OUT2, but DIRT (cooling action) is already used for OUT1 or PID mode is not used for OUT1 (that is PB1 or PB2 =0, and T11 or T12 =0)	Check and correct setup values of OUT2, PB1, PB2, T11, T12 and OUT1. IF OUT2 is required for cooling control, the control should use PID mode(PB = 0, TI = 0) andOUT1 should use reverse mode (heating action), otherwise, don't use OUT2 for cooling control

Error Code	Display Symbol	Error Description	Corrective Action
5	Er 05	Illegal setup values used: unequal IN1U and IN2U or unequal DP1 and DP2 while P1-2 or P2-1 is used for PVMD or, PV1 or PV2 is used for SPMD or, P1.2.H, P1.2.L, D1.2.H or D1.2.L is used for A1FN or A2FN.	Check and correct setup values of IN1U, IN2U, DP1, DP2, PVMD, SPMD, A1FN or A2FN. Same unit and decimal point Should be used if both PV1 and PV2 are used for PV, SV, alarm1 or alarm 2.
6	Er 06	Illegal setup values used: OUT2 select =AL2 but A2FN select NONE	Check and correct setup values of OUT2 and A2FN. OUT2 will not perform alarm function if A2FN select NONE.
7	Er 07	Illegal setup values used: Dwell timer (TIMR) is selected for both A1FN and A2FN.	Check and correct setup values of A1FN and A2FN. Dwell timer can only be properly used for single alarm output.
9	Er 09	Communication error: receive error due to parity error, framing error, overrun error, receive buffer full error, frame check-sum error or receive disturbed	<ol style="list-style-type: none"> 1. Correct the communication software to meet the protocol requirements 2. Add a terminating resistor to the multi-drop link (RS-485) to minimize the noise. 3. Use twisted pair wire for RS-485 interface connection to minimize the noise. 4. Check the polarity of RS-485 interface connection.
10	Er 10	Communication error: bad function code	Correct the communication software to meet the protocol requirements.
11	Er 11	Communication error: register address out of range	Don't issue an over- range address of register to the slave.
12	Er 12	Communication error: access a non-existent parameter	Don't issue a non- existent parameter to the slave.
14	Er 14	Communication error: attempt to write a read only data	Don't write a read only data or a protected data to the slave.
15	Er 15	Communication error: write a value which is out of range to a register	Don't write an over- range data to the slave register.
17	Er 17	Computing error: Illegal (abnormal) floating point data	Software bug. Return to factory for repair.
18	Er 18	Computing error: Arithmetic result overflow or underflow	Software bug. Return to factory for repair.
19	Er 19	Computing error: divided by zero	Don't use an equal value for AOLO and AOHI.
20	Er 20	Computing error: Illegal BCD data entry	Software bug. Return to factory for repair.
21	Er 21	Timing error: A to D conversion data error due to overrun	A to D converter doesn't work properly. Return to factory for repair.
22	Er 22	Timing error: check-sum error received during multi-chip communication procedure	<ol style="list-style-type: none"> 1. Correct the multi-chip communication software to meet the protocol requirement. 2. Return to factory for repair.
23	Er 23	Timing error: wrong function code received during multi-chip communication procedure	<ol style="list-style-type: none"> 1. Correct the multi-chip communication software to meet the protocol requirement. 2. Return to factory for Repair.

Error Code	Display Symbol	Error Description	Corrective Action
26	AtEr	Fail to perform auto-tuning function	<ol style="list-style-type: none"> 1. The PID values obtained after auto-tuning procedure are out of range. Retry auto-tuning. 2. Don't change set point value during auto-tuning procedure. 3. Don't change Event input state during auto-tuning procedure. 4. Use manual tuning instead of auto-tuning.
27	CAER	Incorrect calibration procedure or tolerance of analog component too big to meet specified accuracy	<ol style="list-style-type: none"> 1. Pay more attention to the calibration procedures. 2. Return to factory for repair.
28	CAPE	Memory comparison error, different value detected in the EEPROM and mapped RAM	<ol style="list-style-type: none"> 1. Check and correct the wiring and grounding problems to minimize the system noise. 2. Return to factory for repair.
29	EEPE	EEPROM can't be written correctly	Return to factory for repair.
32	CJER	Cold junction compensation device(s) malfunction	Return to factory for repair.
33	YYER	Key switch shorted or related PCB circuit shorted	Return to factory for repair.
34	LLL2	Input 2 (IN2) signal too low	<ol style="list-style-type: none"> 1. Check if the input 2 sensor used is accordant with IN2 type selection. 2. Check the connection polarity of input 2 sensor. 3. Replace input 2 sensor.
35	HHH2	Input 2 (IN2) signal too high	<ol style="list-style-type: none"> 1. Check if the input 2 sensor used is accordant with IN2 type selection. 2. Replace input 2 sensor.
36	LLL1	Input 1 (IN1) signal too low	<ol style="list-style-type: none"> 1. Check if the input 1 sensor used is accordant with IN1 type selection. 2. Check the connection polarity of input 1 sensor. 3. Replace input 1 sensor.
37	HHH1	Input 1 (IN1) signal too high	<ol style="list-style-type: none"> 1. Check if the input 1 sensor used is accordant with IN1 type selection. 2. Replace input 1 Sensor.
38	SB2E	Input 2 (IN2) sensor break, or input 2 current below 1 mA if 4-20 mA is selected, or input 2 voltage below 0.25V if 1 - 5V is selected	Replace input 2 sensor.
39	SB1E	Input 1 (IN1) sensor break, or input 1 current below 1 mA if 4-20 mA is selected, or input 1 voltage below 0.25V if 1 - 5V is selected	Replace input 1 sensor.
40	ADER	A to D converter or related component(s) malfunction	Return to factory for repair.

5-32 Error Messages and Corrective Actions

*B35: PROG CODE Description

Parameter Value	Specified product
0.XX	BTC-2500 controller
1.XX	BTC-4300 controller
2.XX	BTC-9500 controller
3.XX	BTC-8300 controller
4.XX	BTC-4300 controller & Process Control card of PR
5.XX	BTC-7200 controller
6.XX	BTC-9100 controller
7.XX	SM-40A smart panel meter
8.XX	Reserved
9.XX	ST-30A smart transmitter
10.XX	Reserved
11.XX	Reserved
12.XX	Reserved
13.XX	Reserved
14.XX	ST-20A smart transmitter (software setup)
15.XX	ST-20A smart transmitter (DIP switches setup)

5-33 PROG Code

***B36:** Display Symbol and Description of MODE

Parameter Value	Description
X.0	Perform normal mode
X.1	Enter calibration mode
X.2	Enter auto-tuning mode
X.3	Enter failure mode
X.4	Enter manual mode
X.5	Enter sleep mode
0.X	Unlock condition
1.X	SP1, SEL1 SEL5 are unlocked
2.X	Lock all parameters except SP1
3.X	All parameters are locked

5-34 Mode

***C:** The Parameters are pre-set with the default values specified in the table.

***E:** The unit PV means that the unit of parameter is the same as the unit of PV (process value). The unit of PV is determined by PVMD, IN1, IN2, IN1U, and IN2U.

***E1:** Unit determination for A1SP, A1DV and A1HY

If A1FN=	Range of A1SP same as range of
DE.HI, DE.LO, DB.HI, DB.LO	PV
PV1.H, PV1.L	PV1
PV2.H, PV.L	PV2
P1.2.H, P1.2.L, D1.2.H, D1.2.L	PV1, PV2

5-35 Unit Determination for A1SP, A1DV, A1HY

***E2:** Unit determination for A2SP, A2DV and A2HY

If A2FN=	Range of A2SP same as range of
DE.HI, DE.LO, DB.HI, DB.LO	PV

If A2FN=	Range of A2SP same as range of
PV1.H, PV1.L	PV1
PV2.H, PV.L	PV2
P1.2.H, P1.2.L, D1.2.H, D1.2.L	PV1, PV2

5-36 Unit Determination for A2SP, A2DV, A2HY

*E3: Unit determination for Ramp

If SPMD=	Unit
MIN.R	PV/Minute
HR.R	PV/Hour

5-37 Ramp Unit

*E4: Unit determination for AOLO and AOHI

If AOFN=	Same Unit as Unit of
PV1	PV1
PV2	PV2
P1-2, P2-1	PV1, PV2
SV	PV
MV1, MV2	%

5-38 Unit Determination of AOLO & AOHI

*E5: Unit is the same as unit of PV1 (IN1)

*E6: Unit is the same as unit of PV2 (IN2)

5.2.2.1.1 Default

This will allow the user to load the default values of the Process Control Card Parameters

5.2.3 Channel

The Channel will allow the user to configure the channels to be logged in the recorder from PID process control card. Press Channel and then press Enter Soft key to access the Channel parameter of Process Control Card.

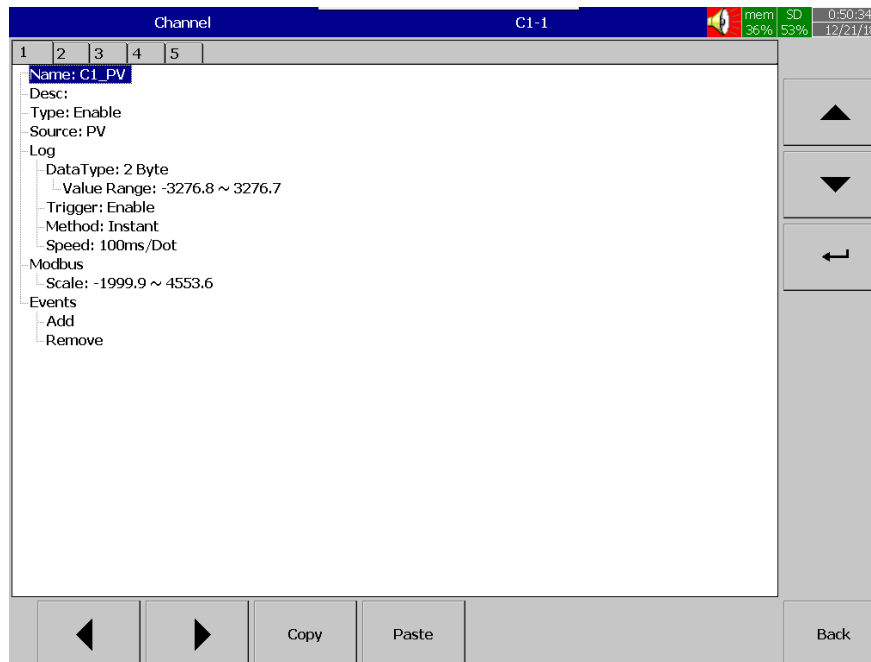

After entering the Configuration menu, in the Channel, select Controller then Press the **Enter** soft key to get into Controller Channel configuration menu. After entering particular controller configuration menu then selects channel then press **Enter** to enter in to controller channel configuration menu. It displays the Controller **C1** channel **C1-1(C1_PV)** as the first Controller channel configuration page. Press directional

navigation keys  at the bottom to select other channels. Press directional keys



on the right hand side to select the column. After completing Configuration, press

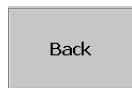

soft key, then press



soft key and then press



soft key to return to main display. All configurations will be saved automatically.

There are five channels available for every PID Process control card for logging. They are listed as below.

1. C1_PV – Process Value
2. C1_SV- Set Value
3. C1_ALM - Alarm
4. C1_EROR - Error
5. C1_Profile ERROR – Profile Error

Similar to C1 PID Process control card C2, C3, C4, C5, C6, C7, C8 PID process control card parameters also available, depends on the recorder model no and their connection on the recorder

5.2.3.1 Name

Enables the User to define the name for each channel with a maximum of 18 characters. Select “Name”, then Press “**Enter**”, soft key, a keyboard with several keys will appear. Press “**Shift**” to select special characters. Press “**Caps**” to select capital letters. Press soft key “**OK**” after entering a new channel name.

5.2.3.2 Desc

The description about a specific channel on the recorder.

5.2.3.3 Type

Option available to enable or disable the channel

5.2.3.4 Source

There are five parameters from each PID process control cards are available as source logging. They are listed as below

1. **PV** – Process Value
2. **SV** - Set Value
3. **ALM** - Alarm
4. **EROR** - Error
5. **ProfileERROR** – Profile Error

The first channel of every PID Process control card will always show PV as the source. Similar to this SV, ALM, EROR and ProfileERROR are available as source in second, third, fourth and fifth channels of every PID Process control card. The source can't be changed by the user. The user can only enable or disable the channel from the logging. These parameters can be logged to the recorder by enabling those channels in

the type. By using the   Key to switch between Channels.

5.2.3.5 Log

5.2.3.5.1 Data Type

The data type for logging is 2 byte.
2 byte range: -32767 to +32767

5.2.3.5.2 Trigger

Two options are available for the user to select.

1. **Disable**: Select disable while the recording of a specific channel is not required at this time
2. **Enable**: Select enable while the recording of a specific channel is required at this time

5.2.3.5.3 Method

This is the method of logging measured data. Select the column **Method** and press **Enter**. Then choose the required Log method from the available methods Instant, Average, Minimum or Maximum of data.

5.2.3.5.3.1 Instant

Logging the last measured data at the logging interval

5.2.3.5.3.2 Average

Logging the averaged of sampled measured data at the logging interval

5.2.3.5.3.3 Minimum

Logging the minimum of sampled measured data at the logging interval

5.2.3.5.3.4 Maximum

Logging the maximum of sampled measured data at the logging interval

5.2.3.5.4 Speed

It is the logging speed (recording speed) of measured data. The available log speeds are as below.

1. 100 msec/dot
2. 1 Sec/dot

3. 2 Sec/dot
4. 5 Sec/dot
5. 10 Sec/dot
6. 15 Sec/dot
7. 20 Sec/dot
8. 30 Sec/dot
9. 1 min/dot
10. 2 min/dot
11. 5 min/dot
12. 15 min/dot
13. 1 hour/dot
14. 2 hour/dot

5.2.3.6 Modbus

The scaling of the channel value in Modbus communication.

5.2.3.7 Events

Events are frequently used for Alarm purposes. The events can be used to operate digital outputs (DO), Timer, Totalizer, Counter or Report. There are maximum five events can be added to each analog input.

Press “Add” to add new event and press “Remove” to remove selected event

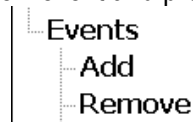

5.2.3.7.1 Type

There are various types of events are available for the user to select for job or alarm purpose. They are listed as below.

5.2.3.7.1.1 H

It is high event. When the process value is higher than high limit, then the alarm or job associated with this event is actuated.

5.2.3.7.1.2 L

It is low event. When the process value is lower than low limit, then the alarm or job associated with this event is actuated.

5.2.3.7.1.3 HH

It is high high event. When the process value is higher than high high limit, then the alarm or job associated with this event is actuated. This is another limit higher than high limit for double warning.

5.2.3.7.1.4 LL

It is low low event. When the process value is lower than low low limit, then the alarm or job associated with this event is actuated. This is another limit lower than low limit for double warning.

5.2.3.7.1.5 Dev+

It is deviation+ event. This event will be triggered on the positive deviation of process value. The job or alarm is activated when the process value is deviated by the value higher than set point from the previous process value.

For example,

Set point = 10

At 10.00.01 Hrs, Tag1 = 40

At 10.00.02 Hrs, Tag1 = 51

Then, job or alarm is activated

5.2.3.7.1.6 Dev-

It is deviation- event. This event will be triggered on the negative deviation of process value. The job or alarm is activated when the process value is deviated by the value lower than set point from the previous process value.

For example,

Set point = 10

At 10.00.01 Hrs, Tag1 = 40

At 10.00.02 Hrs, Tag1 = 29

Then, job or alarm is activated.

5.2.3.7.1.7 Error

It is error event. This event will be activated when there is an error on the input of the channel.

5.2.3.7.2 Set point

Set point for the event.

5.2.3.7.2.1 Hysteresis

To avoid the alarm or event been activated too often, Hysteresis value can be defined for the event trigger set point.

5.2.3.7.2.2 Holding time

To avoid the alarm or event been activated too often, the holding time can be defined for the event trigger set point. In process sometimes SP is reached but it will go down immediately, this might due to process instability. To avoid these kind of nuisance situations, the holding time can be used to see that PV stays at above that SP more than the holding time and then only activate the action for that event. The range of holding time can be set from 1 min to 60 min.

5.2.3.7.3 Log

The event can be logged as alarm or event. They can be selected from the available options. They are as below.

5.2.3.7.3.1 Log Alarm

Log the event as Alarm.

5.2.3.7.3.2 Log Alarm (Auto Ack)

Log the event as alarms and acknowledge automatically

5.2.3.7.3.3 Log Event

Log as event

5.2.3.7.4 Job1 & Job2

The job is called as a task to be performed when the event is activated. There are two jobs Job1 and Job2 can be added to perform in any event.

A typical example is to trigger **an alarm buzzer** in the event of a high temperature. Each channel can accept five different types of events (or alarms) and each event can create two jobs. Please note that a job under Event is different from a job perform by **Operate** key. The job is actuated by an event, and the Operate is actuated by manual control, no event necessary.

Note: Please refer to the section [Jobs](#) for full details about various jobs available

Note: Number of controller channels shown on the controller screen depends on number of PID process control cards inserted in the paperless recorder.

5.2.4 Configuration of Process Control Card

5.2.4.1 Heat Only ON-OFF Control

Select REVR for OUT1, Set PB1 to 0, SP1 is used to adjust set point value, O1HY is used to adjust dead band for ON-OFF control, and TIME is used to adjust the dwell timer (enabled by selecting TIMR for A1FN or A2FN). The output 1 hysteresis (O1HY) is enabled in case of PB1 = 0. The heat only on-off control function is shown in the following diagram.

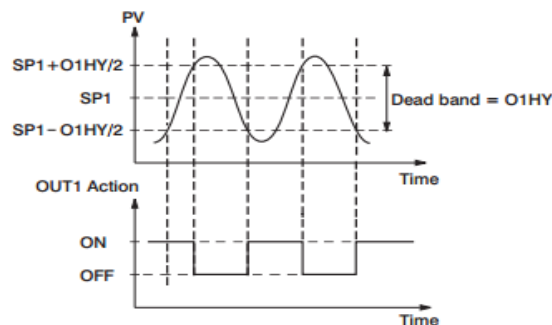

The ON-OFF control may introduce excessive process oscillation even if Hysteresis is minimized to the smallest. If ON-OFF control is set (i.e. PB1 = 0), TI1, TD1, CYC1, OFST, CPB and PL1 will be hidden and have no function to the system. The manual mode, auto-tuning, self-tuning and Bumpless transfer will be disabled too.

Select REVR for OUT1, set TI1 to 0, SP1 is used to adjust set point value; TIME is used to adjust the dwell timer (enabled by selecting TIMR for A1FN or A2FN). OFST been enabled in case of TI1 = 0 is used to adjust the control offset (manual reset). Adjust CYC1 according to the output 1 type (O1TY). Generally, CYC1 = 0.5 ~ 2 sec for SSRD and SSR, CYC1 = 10 ~ 20 sec for relay output. CYC1 is ignored if linear output is selected for O1TY. If PB1 is not equal to 0.

OFST is measured by % with range 0 - 100.0 %. In the steady state (i.e. process has been stabilized) if the process value is lower than the set point a definite value, say 5 C, while 20 C is used for PB1, that is lower 25%, then increase OFST 25%, and vice versa. After adjusting OFST value, the process value will be varied and eventually, coincide with set point.

Using the P control (TI1 set to 0), the auto-tuning and self-tuning are disabled. Manual reset (adjust OFST) is not practical because the load may change from time to time and often need to adjust OFST repeatedly. The PID control can avoid this situation. Selecting REVR for OUT1, SP1 is used to adjust set point value.

TIME is used to adjust the dwell timer (enabled by selecting TIMR for A1FN or A2FN). PB1 and TI1 should not be zero. Adjust CYC1 according to the output 1 type (O1TY). Generally, CYC1 = 0.5 ~ 2 sec for SSRD and SSR, CYC1 = 10 ~ 20 sec for relay output. CYC1 is ignored if linear output is selected for O1TY.

In most cases the self-tuning can be used to substitute the auto-tuning. See if self-tuning is not used (select NONE for SELF), then use auto-tuning for the new process, or set PB1, TI1 and TD1 with historical values. If the control result is still unsatisfactory, then use manual tuning to improve the control.

This Process Control Card contains a very clever PID and Fuzzy algorithm to achieve a very small overshoot and very quick response to the process if it is properly tuned.

5.2.4.2 Cool Only ON-OFF Control

ON-OFF control, P (PD) control and PID control can be used for cool control. Set OUT1 to DIRT (direct action). The other functions for cool only ON-OFF control, cool only P (PD) control and cool only PID control are same as Heat only ON-OFF Control except that the output variable (and action) for the cool control is inverse to the heat control, such as the following diagram shows:

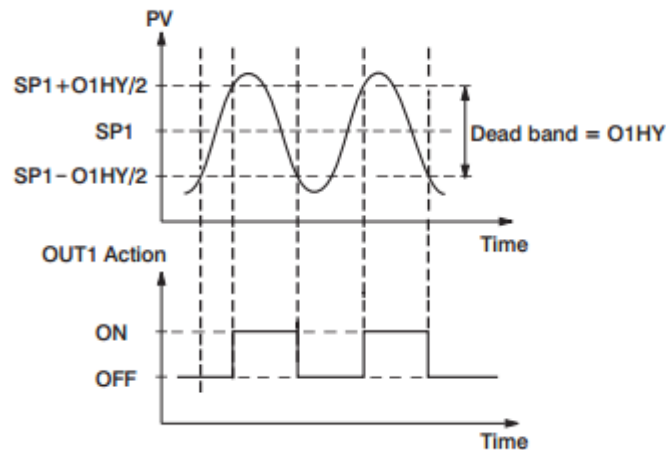

5.2.4.3 Heat Cool Control

The Heat - Cool Control can use one of 6 combinations of control modes. Setups of Parameters for each control mode are shown in the following table.

Control Modes	Heat Uses	Cool Uses	Setup Values											
			OUT1	OUT2	O1HY	OFST	PB1	TI1	TD1	CPB	DB	A1FN or A2FN	A1MD or A2MD	A1HY or A2HY
Heat : ON-OFF Cool : ON-OFF	OUT1	ALM1 or ALM2	REVR	NONE	☆	×	=0	×	×	×	×	DE.HI or PV1.H	NORM	☆
Heat : ON-OFF Cool : P (PD)	ALM1 or ALM2	OUT1	DIRT	NONE	×	☆	≠0	=0	☆	×	×	DE.LO or PV1.L	NORM	☆
Heat : ON-OFF Cool : PID	ALM1 or ALM2	OUT1	DIRT	NONE	×	×	≠0	≠0	☆	×	×	DE.LO or PV1.L	NORM	☆
Heat : P (PD) Cool : ON-OFF	OUT1	ALM1 or ALM2	REVR	NONE	×	☆	≠0	=0	☆	×	×	DE.HI or PV1.H	NORM	☆
Heat : PID Cool : ON-OFF	OUT1	ALM1 or ALM2	REVR	NONE	×	×	≠0	≠0	☆	×	×	DE.HI or PV1.H	NORM	☆
Heat : PID Cool : PID	OUT1	OUT2	REVR	COOL	×	×	≠0	≠0	☆	☆	☆	×	×	×

- × : Don't care
- ☆ : Adjust to meet process requirements

Note

The ON-OFF control may result excessive overshoot and undershoot problems in the process. The P (or PD) control will result in a deviation process value from the set point. It is recommended to use PID control for the Heat-Cool control to produce a stable and zero offset process value.

Other Setup Required

O1TY, CYC1, O2TY, CYC2, A2SP, A2DV, O1TY & O2TY are set in accordance with the types of OUT1 & OUT2 installed. CYC1 & CYC2 are selected according to the output 1 type (O1TY) & output 2 type (O2TY). Generally, selects 0.5 ~ 2 sec. for CYC1, if SSRD or SSR is used for O1TY; 10 ~ 20 sec. if relay is used for O1TY, and CYC1 is ignored if linear output is used. Similar condition is applied for CYC2 selection.

Examples

Heat PID + Cool ON-OFF: Set OUT1 = REVR, A1FN or A2FN = PV1.H, A1FN or A2MD = NORM, A1HY or A2HY=0.1, PB1=0, TI1=0, TD1=0, and set appropriate values for O1TY and CYC1.

Heat PID + Cool PID: set OUT1=REVR, OUT2=COOL, CPB=100, DB=-4.0, PB1=0, TI1=0, TD1=0, and set appropriate values for O1TY, CYC1, O2TY, and CYC2.

CPB Programming

The cooling proportional band is measured by % of PB with range 1~255. Initially set 100% for CPB and examine the cooling effect. If cooling action should be enhanced then decrease CPB .If cooling action is too strong then increase CPB. The value of CPB is related to PB and its value remains unchanged throughout the self-tuning and auto-tuning procedures.

Adjustment of CPB is related to the cooling media used. For air is used as cooling media, adjust CPB at 100(%). For oil is used as cooling media, adjust CPB at 125(%). For water is used as cooling media, adjust CPB at 250(%)

DB Programming

Adjustment of DB is dependent on the system requirements. If more positive value of DB (greater dead band) is used, an unwanted cooling action can be avoided but an excessive overshoot over the set point will occur. If more negative value of DB (greater overlap) is used, an excessive overshoot over the set point can be minimized but an unwanted cooling action will occur. It is adjustable in the range - 36.0% to 36.0% of PB1 (or PB2 if PB2 is selected). A negative DB value shows an overlap area over which both outputs are active. A positive DB value shows a dead band area over which neither output is active

5.2.4.4 Heater Break Alarm

A current transformer TEC99999 should be installed to detect the heater current if a heater break alarm is required. The CT signal is sent to input 2, and the PV2 will indicate the heater current in 0.1 Amp. resolution. The range of current transformer is 0 to 50.0 Amps.

Example

A furnace uses two 2KW heaters connected in parallel to warm up the process. The line voltage is 220V and the rating current for each heater is 9.09A. If we want to detect any one heater break, set A1SP=13.0A, A1HY=0.1 A1FN=PV2.L, A1MD=NORM, then

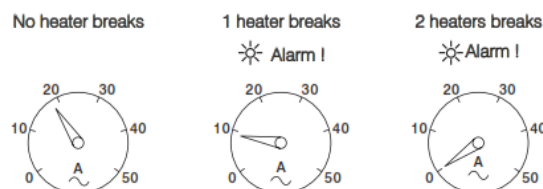

5.2.4.5 Loop Break Alarm

A1FN selects LB if alarm 1 is required to act as a loop break alarm. Similarly, if alarm 2 is required to act as a loop break alarm, then set OUT2 with=AL2 and A1FN with LB.TIME, A1SP, A1DV and A1HY are hidden if alarm 1 is configured as a loop break alarm. Similarly, TIME, A2SP, A2DV and A2HY are hidden if alarm 2 is configured as a loop break alarm.

One of 4 kinds of alarm modes can be selected for alarm 1 and alarm 2. These are: Normal alarm, Latching alarm, Holding alarm and Latching/Holding alarm. However, the Holding mode and latching/Holding mode are not recommended to be chosen for loop break alarm since loop break alarm will not perform holding function even if it is set with holding or latching/holding mode.

Loop Break Conditions are detected during a time interval of 2T11 (double of integral time, but 120 seconds maximum). Hence the loop break alarm doesn't respond quickly as it occurs. If the process value doesn't increase (or decrease) while the control variable MV1 has reached to its maximum (or minimum) value within the detecting time interval, a loop break alarm (if configured) will be actuated.

Loop Break Alarm (if configured) occurs when any of the following condition happens

- 1 Input sensor is disconnected (or broken).
- 2 Input sensor is shorted.
- 3 Input sensor is defective.
- 4 Input sensor is installed outside (isolated from) the process.
- 5 Controller fails (A-D converter damaged).
- 6 Heater (or generally, chillers, valve, pump, motor etc.) breaks or fails or uninstalled
- 7 Switching device (used to drive heater) is open or shorted.

5.2.4.6 Sensor Break Alarm

Alarm 1 or alarm 2 can be configured as sensor break alarm by selecting SENB for A1FN or A2FN. The sensor break alarm is activated as soon as failure mode occurs. Note that A-D failure also creates a sensor break alarm. TIME, A1SP, A1DV, and A1HY are hidden if alarm 1 is configured as a sensor break alarm. Similarly, TIME, A2SP, A2DV and A2HY are hidden if alarm 2 is configured as a sensor break alarm.

One of 4 kinds of alarm modes can be selected for sensor break alarm. These are: Normal alarm, Latching alarm, Holding alarm and Latching/Holding alarm. However, the Holding alarm and Latching/Holding alarm are not recommended to be chosen for sensor break alarm since sensor break alarm will not perform holding function even if it is set with holding or latching/holding mode.

5.2.4.7 Failure Transfer

The controller will enter failure mode as one of the following conditions occurs.

- 1 SB1E Error occurs (due to the input 1 sensor break or input 1 current below 1mA, if 4-20mA is selected or input 1 voltage below 0.25V if 1-5 V is selected), if PV1, P1-2 or P2-1 is selected for PVMD or PV1 is selected for SPMD.
- 2 SB2E Error occurs (due to the input 2 sensor break or input 2 current below 1mA, if 4-20 mA is selected or input 2 voltage below 0.25V if 1-5 V is selected), if PV2, P1-2 or P2-1 is selected for PVMD or PV2 is selected for SPMD.
- 3 ADER Error occurs due to the A-D converter of the controller fails.

The output 1 and output 2 will perform the failure transfer function as one of the following conditions occurs.

- 1 During power starts (within 2.5 seconds).
- 2 The controller enters the failure mode.
- 3 The controller enters the manual mode.
- 4 The controller enters the calibration mode.

Output 1 Failure Transfer, if activated, will perform

- 1 If output 1 is configured as proportional control (PB1≠0), and BPLS selected for O1FT, then output 1 will perform Bumpless transfer. There after the previous averaging value of MV1 will be used for controlling output 1.
- 2 If output 1 is configured as proportional control (PB1 ≠ 0), and a value of 0 to 100.0 % is set for O1FT, then output 1 will perform failure transfer. There after the value of O1FT will be used for controlling output 1.
- 3 If output 1 is configured as ON-OFF control (PB1 = 0), then output 1 will be driven OFF if O1FN selects REVR and be driven ON if O1FN selects DIRT.

- If output 1 is configured as ON-OFF control (PB1=0), then output 1 will be driven OFF if O1FN selects REVR and be driven ON if O1FN selects DIRT.

Output 2 Failure Transfer, if activated, will perform

- If OUT2 selects COOL, and BPLS is selected for O1FT, then output 2 will perform Bumpless transfer. There after the previous averaging value of MV2 will be used for controlling output 2.
- If OUT2 selects COOL, and a value of 0 to 100.0% is set for O2FT, then output 2 will perform failure transfer. Thereafter the value of O2FT will be used for controlling output 2.

Alarm 1 Failure Transfer is activated as the controller enters failure mode. Thereafter the alarm 1 will transfer to the ON or OFF state pre-set by A1FT.

Exception

If Loop Break (LB) alarm or Sensor Break (SENB) alarm is configured for A1FN, the alarm 1 will be switched to ON state independent of the setting of A1FT. If Dwell Timer (TIMR) is configured for A1FN, the alarm 1 will not perform failure transfer.

Alarm 2 Failure Transfer is activated as the controller enters failure mode. There after the alarm 2 will transfer to the ON or OFF state pre-set by A2FT. Alarm 2 Failure Transfer is activated as the controller enters failure mode.

Exception

If Loop Break (LB) alarm or sensor Break (SENB) alarm is configured for A2FN, the alarm 2 will be switched to ON state independent of the setting of A2FT. If Dwell Timer (TIMR) is configured for A2FN, the alarm 2 will not perform failure transfer.

5.2.4.8 Bumpless Transfer

The Bumpless transfer function is available for output 1 and output 2 (provided that OUT2 is configured as COOL). Bumpless Transfer is enabled by selecting BPLS for O1FT and/or O2FT and activated as one of the following cases occurs.

- Power starts (within 2.5 seconds).
- The controller enters the failure mode.
- The controller enters the manual mode.
- The controller enters the calibration mode.

As the Bumpless transfer is activated, the controller will transfer to open-loop control and uses the previous averaging value of MV1 and MV2 to continue control.

5.2.4.8.1 Without Bumpless Transfer

Since the hardware and software need time to be initialized, the control is abnormal as the power is recovered and results in a large disturbance to the process. During the sensor breaks, the process loses power.

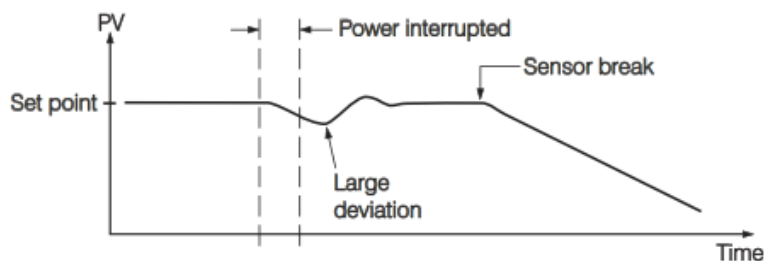

5.2.4.8.2 With Bumpless Transfer

After Bumpless transfer is configured with the correct control variables applied, the disturbance is small when the power is recovered. During the sensor breaks, the controller continues to control by using its previous value. If the load doesn't change, the process will remain stable. Thereafter, once the load changes, the process may run away. Therefore, the user should not rely on a Bumpless transfer for a longer

time. For fail safe reason, an additional alarm should be used to announce the operator when the system fails. For a Sensor Break Alarm, if configured, will switch to failure state and announces the operator to use manual control or take a proper security action when the system enters failure mode.

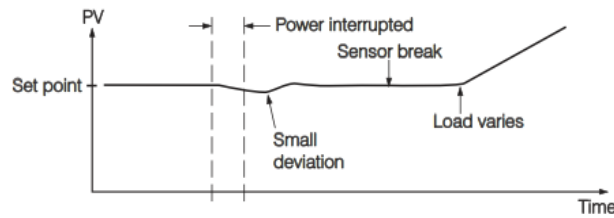

Warning: After system fails, never depend on Bumpless transfer for a long time; otherwise it might cause a problem to the system to run away.

5.2.4.9 PV1 Shift

In certain applications it is desirable to shift the controller display value from its actual value. This can be easily accomplished by using the PV1 shift function. Press the "scroll" key to the parameter SHIF in card parameter. The value you adjust here, either positive or negative, will be added to the actual value. The SHIF function will alter PV1 only.

Here is an example. A process is equipped with a heater, a sensor and a subject to be warmed up. Due to the design and position of the components in the system, the sensor could not be placed any closer to the part. Thermal gradient (different temperature) is common and necessary to an extent in any thermal system for heat to be transferred from one point to another. If the difference between the sensor and the subject is 35 C, and the desired temperature at the subject to be heated is 200 C, the controlling value or the temperature at the sensor should be 235 C. You should input -35 C as to subtract 35 C from the actual process display. This in turn will cause the controller to energize the load and bring the process display up to the set point value

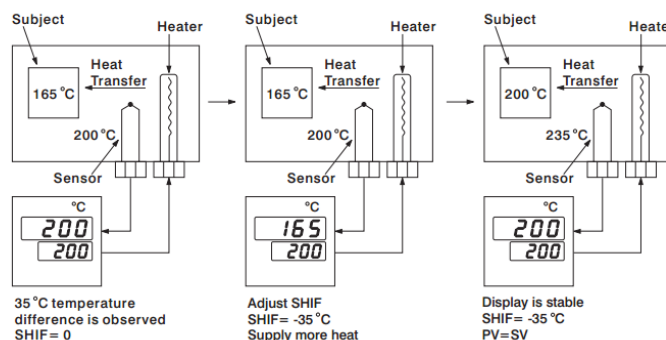

5.2.4.10 SP1 Range

SP1L (SP1 low limit value) and SP1H (SP1 high limit value) in setup menu are used to confine the adjustment range of SP1.

Example: A freezer is working in its normal temperature range -10°C to -15°C. In order to avoid an abnormal set point, SP1L and SP1H are set with the following values: SP1L = -15°C, SP1H = -10°C. Now SP1 can only be adjusted within the range from -10 C to -15 C.

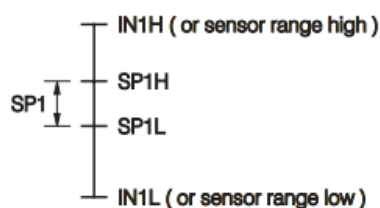

5.2.4.11 Dwell Timer

Alarm 1 or Alarm 2 can be configured as dwell timer by selecting TIMR for A1FN or A2FN, but not both, otherwise Error will appear. As the dwell timer is configured, the parameter TIME is used for dwell time adjustment. The dwell time is measured in minute ranging from 0 to 6553.5 minutes. Once the process reaches the set point the dwell timer starts to count from zero until time out. The timer relay will remain unchanged until time out. The dwell timer operation is shown as following diagram.

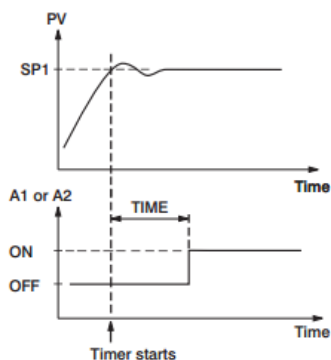

If alarm 1 is configured as dwell timer, A1SP, A1DV, A1HY and A1MD are hidden. Same case is for alarm 2.

Example

Set A1FN=TIMR or A2FN=TIMR but not both. Adjust TIME in minutes. A1MD (if A1FN=TIMR) or A2MD (if A2FN=TIMR) is ignored in this case.

5.2.4.12 Process Alarms

A process alarm sets an absolute trigger level (or temperature). When the process (could be PV1, PV 2 or PV1-PV2) exceeds that absolute trigger level an alarm occurs. A process alarm is independent from set point. Adjust A1FN (Alarm 1 function) in setup menu. One of 8 functions can be selected for process alarm. These are: **PV1.H, PV1.L, PV2.H, PV2.L, P1.2.H, P1.2.L, D1.2.H, and D1.2.L.**

When the PV1.H or PV1.L is selected, the alarm examines the PV1 value. When the PV2.H or PV2.L is selected the alarm examines the PV2 value. When the P1.2.H or P1.2.L is selected the alarm occurs if the PV1 or PV2 value exceed the trigger level. When the D1.2.H or D1.2.L is selected the alarm occurs if the PV1-PV2 (difference) value exceeds the trigger level. The trigger level is determined by A1SP (Alarm 1 set point) and A1HY (Alarm 1 hysteresis value) in configuration for alarm 1. The hysteresis value is introduced to avoid interference action of alarm in a noisy environment. Normally A1HY can be set with a minimum (0.1) value. A1DV and/or A2DV are hidden if alarm 1 and/or alarm 2 are set with process alarm.

5.2.4.12.1 Alarm Modes

One of 4 kinds of alarm modes can be selected for alarm 1 and alarm 2. These are Normal alarm, Latching alarm, Holding alarm and Latching/Holding alarm.

5.2.4.12.1.1 Normal Alarm: A1MD = NORM

When a normal alarm is selected, the alarm output is de-energized in the non-alarm condition and energized in an alarm condition.

5.2.4.12.1.2 Latching Alarm: A1MD = LTCH

If a latching alarm is selected, once the alarm output is energized, it will remain unchanged even if the alarm condition is cleared. The latching alarms are disabled when the power is shut off or if event input is applied with proper selection of EIFN.

5.2.4.12.1.3 Holding Alarm: A1MD = HOLD

A holding alarm prevents an alarm from power up. The alarm is enabled only when the process reaches the set point value (may be SP1 or SP2). Afterwards, the alarm performs same function as normal alarm.

5.2.4.12.1.4 Latching / Holding Alarm: A1MD = LT.HO

A latching / holding alarm performs both holding and latching function.

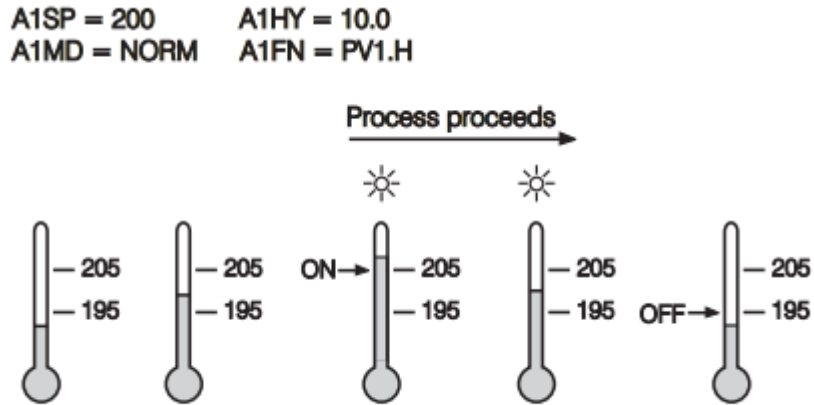

5-1 Normal Process Alarm

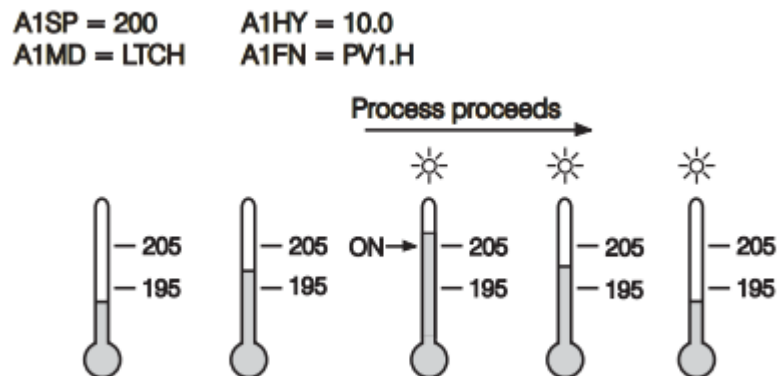

5-2 Latching Process Alarm

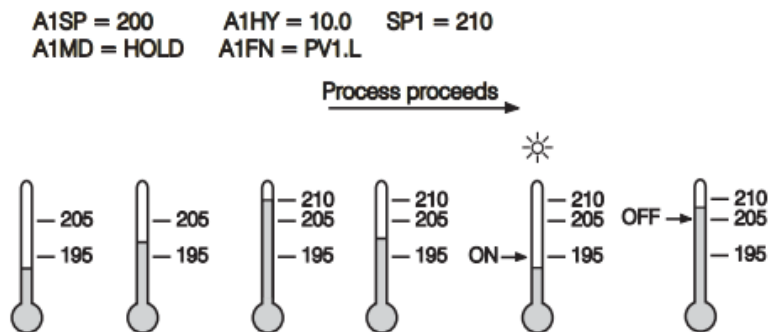

5-3 Holding Process Alarms

A1SP = 200 A1HY = 10.0 SP1 = 210
 A1MD = LT.HO A1FN = PV1.L

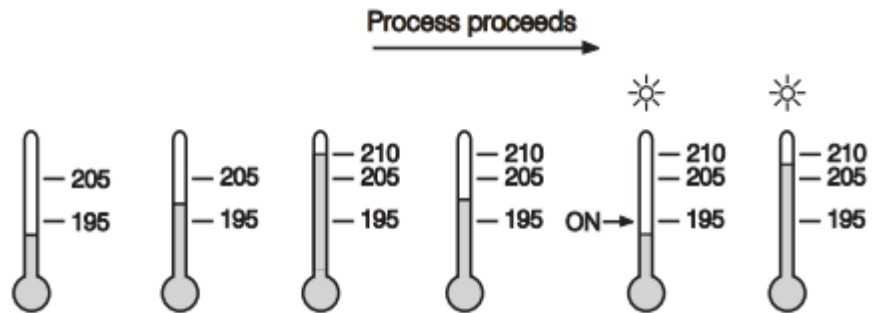

5-4 Latching/Holding Process Alarm

Although the above descriptions are based on alarm 1, the same conditions can be applied to alarm 2.

5.2.4.12.2 Alarm Types

5.2.4.12.2.1 Deviation Alarm

A deviation alarm alerts the user when the process deviates too far from set point. The user can enter a positive or negative deviation value (A1DV, A2DV) for alarm 1 and alarm 2. A hysteresis value (A1HY or A2HY) can be selected to avoid interference problem of alarm in a noisy environment. Normally, A1HY and A2HY can be set with a minimum (0.1) value. Trigger levels of alarm are moving with set point. For alarm 1, Trigger levels = $SP1 + A1DV \pm 1/2 A1HY$. For alarm 2, Trigger levels = $SP1 + A2DV \pm 1/2 A2HY$.

A1SP and/or A2SP are hidden if alarm 1 and/or alarm 2 are set with deviation alarm. One of 4 kinds of alarm modes can be selected for alarm 1 and alarm 2. These are Normal alarm, Latching alarm, Holding alarm and Latching/Holding alarm.

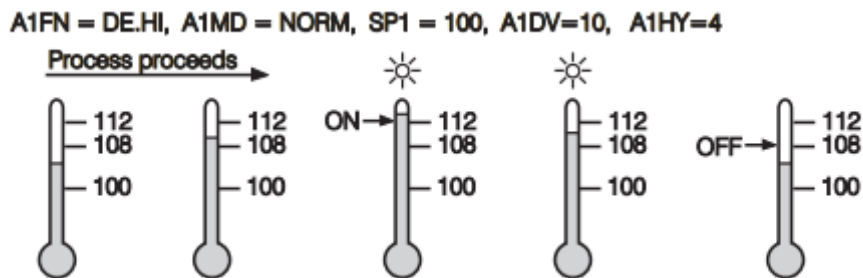

5-5 Normal Deviation Alarm

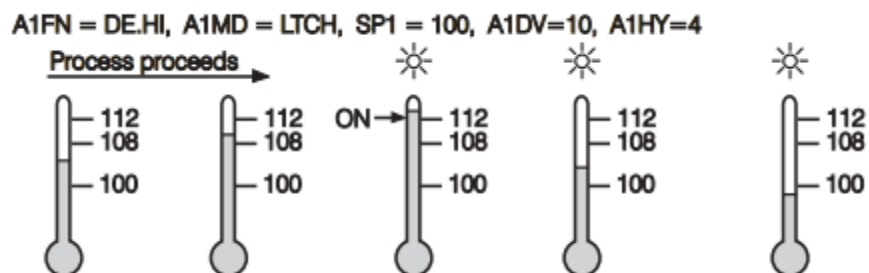

5-6 Latching Deviation Alarm

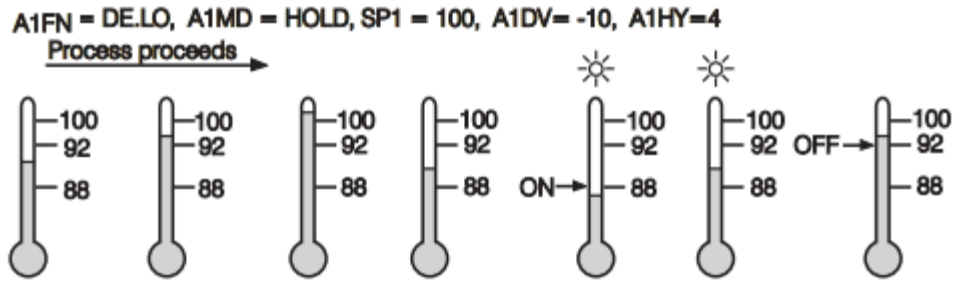

5-7 Holding Deviation Alarm

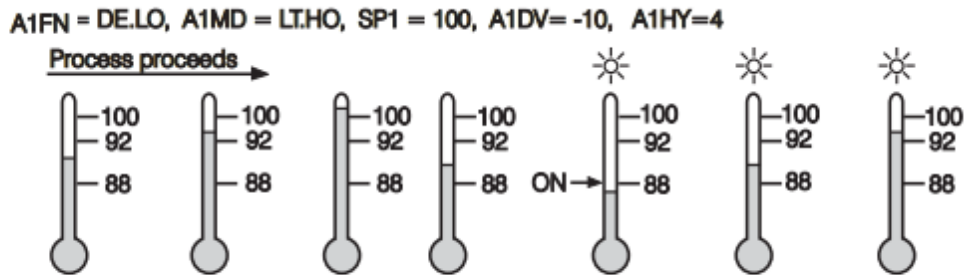

5-8 Latching/Holding Deviation Alarm

5.2.4.12.2.2 Deviation Band Alarm

A deviation band alarm pre-sets two reference levels relative to set point. Two types of deviation band alarm can be configured for alarm 1 and alarm 2. These are deviation band high alarm (A1FN or A2FN select DB.HI) and deviation band low alarm (A1FN or A2FN select DB.LO). A1SP and A1HY are hidden if alarm 1 is selected with deviation band alarm. Similarly, A2SP and A2HY are hidden if alarm 2 is selected with deviation band alarm. Trigger levels of deviation band alarm are moving with set point.

For alarm 1, trigger levels = $SP1 \pm A1DV$.

For alarm 2, trigger levels = $SP1 \pm A2DV$.

One of 4 kinds of alarm modes can be selected for alarm 1 and alarm 2. These are Normal alarm, Latching alarm, Holding alarm and Latching/Holding alarm.

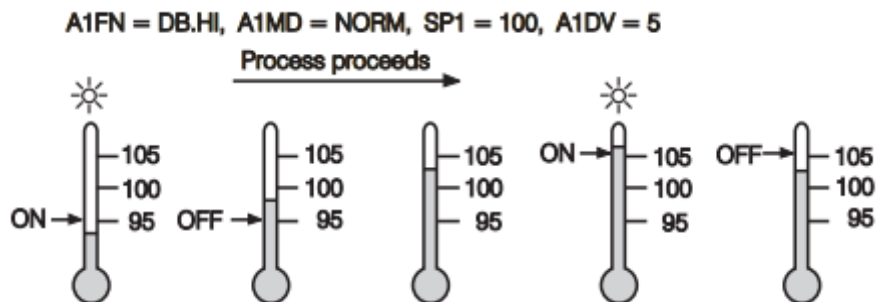

5-9 Normal Deviation Band Alarm

A1FN = DB.LO, A1MD = LTCH, SP1 = 100, A1DV = 5

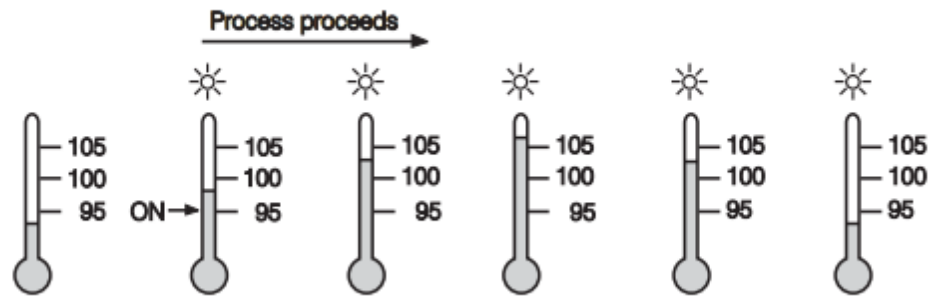

5-10 Latching Deviation Band Alarm

A1FN = DB.HI, A1MD = HOLD, SP1 = 100, A1DV = 5

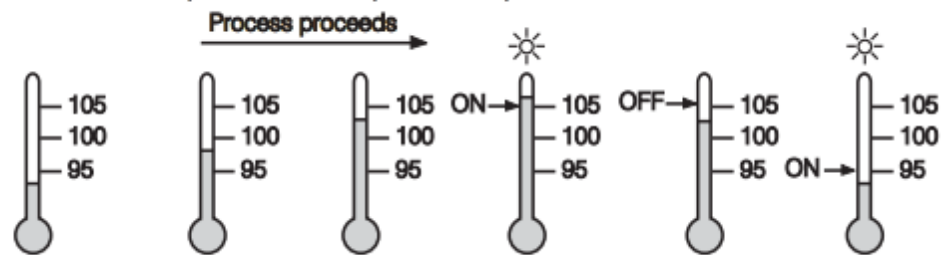

5-11 Holding Deviation Band Alarm

A1FN = DB.HI, A1MD = LT.HO, SP1 = 100, A1DV = 5

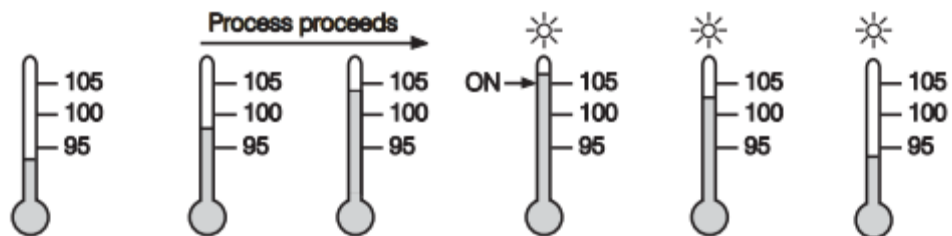

5-12 Latching/Holding Deviation Band Alarm

5.2.4.13 Event Input

The Event input accepts a digital type signal. Three types of signals can be connected to event input. These are Relay or switch contacts Open collector pull low TTL logic level. One of ten available functions can be chosen by using (EIFN) contained in setup menu.

- 1 **NONE:** Event input No function. If chosen, the event input function is disabled. The controller will use PB1, TI1 and TD1 for PID control and SP1 (or other values determined by SPMD) for the set point.
- 2 **SP2:** If chosen, the SP2 will replace the role of SP1 for control. SP2: If chosen, the SP2 will replace the role of SP1 for control.
- 3 **PID2:** If chosen, the second PID set PB2, TI2 and TD2 will be used to replace PB1, TI1 and TD1 for control.
- 4 **SP.P2:** If chosen, the SP2, PB2, TI2 and TD2 will replace SP1, PB1, TI1 and TD1 for control

Note: If the second PID set is chosen during Auto-tuning and/or Self-tuning procedures,

the new PID values will be stored in PB2, TI2 and TD2.

- 5 **RS.A1:** Reset Alarm 1 as the event input is activated. However, if alarm 1 condition is still existent, the alarm 1 will be retriggered again while the event input is released.
- 6 **RS.A2:** Reset Alarm 2 as the event input is activated. However, if alarm 2 conditions are still existent, the alarm 2 will be retriggered again while the event input is released.
- 7 **R.A1.2:** Reset both Alarm 1 and Alarm 2 as the event input is activated. However, if the alarm 1 and/or alarm 2 are still existent, the alarm 1 and/or alarm 2 will be triggered again while the event input is released.
Note: The RS.A1, RS.A2 and R.A1.2 are particularly suitable to be used for a Latching and/or Latching/Holding alarms.
- 8 **D.O1:** Disable Output 1 as the event input is activated. The output 1 control variable MV1 is cleared to zero.
- 9 **D.O2:** Disable Output 2 as the event input is activated. The output 2 control variables MV2 is cleared to zero.
- 10 **D.O1.2:** Disable both Output 1 and Output 2 by clearing MV1 and MV2 values as soon as the event input is activated.
Note: When any of D.O1, D.O2 or D.O1.2 is selected for EIFN, the output 1 and/or output 2 will revert to their normal conditions as soon as the event input is released.
- 11 **LOCK:** All parameters are locked to prevent from being changed.
- 12 **SP2F Function:** Define format of SP2 value. If SP2F in the setup menu is selected with ACTU, the event input function will use SP2 value for its second set point. If SP2F is selected with DEVI, the SP1 value will be added to SP2. The sum of SP1 and SP2 (SP1+SP2) will be used by the event input function for the second set point value. In certain applications it is desirable to move second set point value with respect to set point 1 value. The DEVI function for SP2 provides a convenient way in this case.

5.2.4.14 Second Set Point

In certain applications it is desirable to change the set point automatically without the need to adjust the set point. You can apply a signal to event input terminals. The signal applied to event input may come from a Timer, a PLC, and an Alarm Relay, a Manual switch or other devices. Select SP2 for EIFN which is contained in setup menu. This is available only with the case that SP1.2, MIN.R or HR.R is used for SPMD, where MIN.R and HR.R are used for the ramping function.

Application 1: A process is required to be heated at a higher temperature as soon as its pressure exceeds a certain limit. Set SPMD=SP1.2, EIFN=SP2 (or SP .P2 if the second PID is required for the higher temperature too). The pressure gauge is switched ON as it senses a higher pressure. Connect the output contacts of the pressure gauge to the event input. SP1 is set with a normal temperature and SP2 is set with a higher temperature. Choose ACTU for SP2F.

Application 2: An oven is required to be heated at 300°C from 8.00 AM to 6.00 PM. After 6.00 PM it is desirable to be maintained at 80°C. Use a programmable 24 hours cycle timer for this purpose. The timer output is used to control event input. Set SPMD=SP1.2, and EIFN=SP2 (or SP .P2 if the second PID is required to be used for the second set point). SP1 is set with 300°C and SP2 is set with 80°C. Choose ACTU for SP2F. After 6.00 PM the timer output is closed. The event input function will select SP2 (=80°C) to control the process.

5.2.4.15 Second PID Set

In certain applications the process characteristics is strongly related to its process value. The Process Control Card provides two set of PID values. When the process is changed to different set point, the PID values can be switched to another set to achieve an optimum condition.

The optimal PID values for a process may vary with its process value and set point. Hence if a process is used for a wide range of set point, dual PID values are necessary to optimize the control performance. If the first PID set is selected (event input is not applied) during auto-tuning procedure, the

PID values will be stored in PB1, TI1 and TD1. Similarly, if the second PID set is selected (event input is applied while PID2 or SP.P2 is selected for EIFN) during auto-tuning, the PID values will be stored in PB2, TI2 and TD2 as soon as auto-tuning is completed.

Application 1: Programmed by Set Point

Choose SP.P2 for EIFN then both set point and PID values will be switched to another set simultaneously. The signal applied to event input may come from a Timer, a PLC, and an Alarm Relay, a Manual Switch or other devices.

Application 2: Programmed by Process Value

If the process value exceeds a certain limit, 500°C for example, it is desirable to use another PID values to optimize the control performance. The user can use a process high alarm to detect the limit of the process value. Choose PV1H for A1FN, A1MD selects NORM, adjust A1SP to be equal to 500° C, and choose PID2 for EIFN. If the temperature is higher than 500°C, then alarm 1 is activated. The alarm 1 output is connected to event input; the PID values will change from PB1, TI1 and TD1 to PB2, TI2 and TD2.

5.2.4.16 Ramp & Dwell

5.2.4.16.1.1 Ramp

The ramping function is performed during power up as well as any time the set point is changed. Choose MINR or HRR for SPMD, the unit will perform the ramping function. The ramp rate is programmed by using RAMP which is available in user configuration of Process Control Card

Example without Dwell Timer

Select MINR for SPMD, IN1U selects °C, DP1 selects 1-DP, Set RAMP=10.0. SP1 is set to 200°C initially, and changed to 100°C after 30 minutes since power up. The starting temperature is 30° C. After power up the process is running like the curve shown below

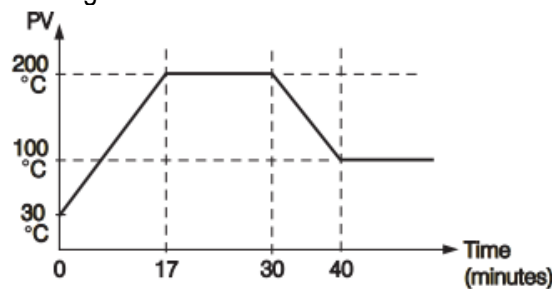

Note: When the ramp function is used, the lower display will show the current ramping value. However it will revert to show the set point value as soon as the up or down key is touched for adjustment. The ramping value is initiated to process value either power up or RAMP and / or set point are changed. Setting RAMP to zero means no ramp function at all.

5.2.4.16.2 Dwell

The Dwell timer can be used separately or accompanied with a Ramp. If A1FN selects TIMR, the alarm 1 will act as a dwell timer. Similarly, alarm 2 will act as a dwell timer if A2FN selects TIMR. The timer is programmed by using TIME which is contained in Configuration menu. The Timer starts to count as soon as the process reaches its set point, and triggers an alarm as time out. Here is an example.

Example with Dwell Timer

Select TIMR for A1FN, IN1U selects F, DP1 selects NODP, Set TIME=30.0, SP1 is set to 400°F initially, and corrected to 200°F before the process reaches 200°F. As the process reaches set point (i.e. 200°F) the timer starts to count. The TIME value can still be corrected without disturbing the Timer, before time out. The TIME is changed to 40.0 after 28 minutes since the process reached its set point. The behaviour of process value and alarm 1 are shown below. Once the timer output was energized it will remain unchanged until power down or an event input programmed for resetting alarm is applied.

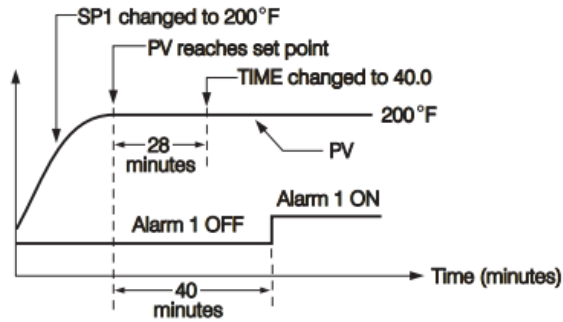

Note: The TIMR can't be chosen for both A1FN and A2FN simultaneously; otherwise an error code will produce.

5.2.4.16.3 Ramp & Dwell

A Ramp can be accompanied with a dwell timer to control the process. Here is an example.

Example Ramp & Dwell Timer

Select HRR for SPMD, IN1U selects PU, DP1 select 2-DP, Set RAMP=60.00 A2FN selects TIMR, Set TIME=20.0 as power is applied the process value starts from 0.00 and set SP1=30.00, SP2=40.00. The timer output is used to control event input.

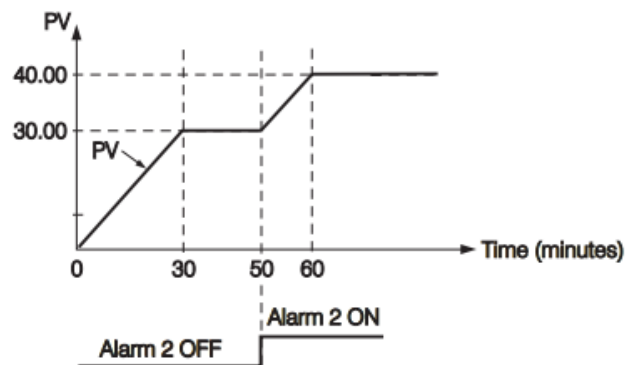

5.2.4.17 Remote Set Point

SPMD selecting PV1 or PV2 will enable the Process Control Card to accept a remote set point signal. If PV1 is selected for SPMD, the remote set point signal is sent to Input 1, and Input 2 is used for process signal input. If PV2 is selected for SPMD, the remote set point signal is sent to Input 2, and Input 1 is used for process signal. To achieve this, set the following parameters in the Configuration menu.

Case 1:

Use Input 2 to accept remote set point

FUNC=FULL

IN2, IN2U, DP2, IN2L, IN2H, are set according to remote signal.

PVMD=PV1

IN1, IN1U, DP1, are set according to the process signal

IN1L, IN1H if available, are set according to the process signal

SPMD= PV2

Case 2:

Use Input 1 to accept remote set point

FUNC=FULL

IN1, IN1U, DP1, IN1L, IN1H, are set according to remote signal.
 PVMD=PV2
 IN2, IN2U, DP2, are set according to the process signal
 IN2L, IN2H if available, are set according to the process signal
 SPMD= PV1

Note: If PV1 are chosen for both SPMD and PVMD, an Error Code will appear. If PV2 are chosen for both SPMD and PVMD, an Error Code will appear. The user should not use these cases, otherwise, the Process Control Card will not control properly.

5.2.4.18 Differential Control

In certain applications it is desirable to control second process such that its process value always deviates from the first process with a constant value. To achieve this, set the following parameter in the Setup menu.

FUNC=FULL

IN1, IN1L, IN1H are set according to input 1 signal

IN2, IN2L, IN2H are set according to input 2 signal

IN1U, DP1, IN2U, DP2, are set according to input 1 and input 2 signal

PVMD=P1-2 or P2-1

SPMD=SP1.2

The response of PV2 will be parallel to PV1 as shown in the following diagram

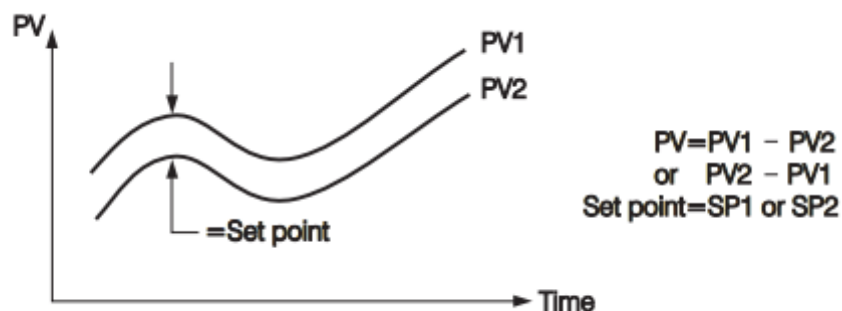

The PV display will indicate PV1-PV2 value if P1-2 is chosen for PVMD or PV2-PV1 value if P2-1 is chosen for PVMD. If the user needs PV1 or PV2 to be displayed instead of PV, they can use the Display Mode to select PV1 or PV2 to be viewed. If PVMD selects P1-2 or P2-1, while SPMD selects PV1 or PV2, an Error Code will appear. In this case the signals used for input 1 and input 2 should be the same unit and same decimal point, that is, IN1U=IN2U, DP1=DP2, otherwise Error Code will appear.

5.2.4.19 Output Power Limit

In certain system the heater (or cooler) is over-designed such that the process is too heavily heated or cooled. To avoid an excessive overshoot and/or undershoot the user can use the Power Limit function. Output 1 power limit PL1 is contained in Configuration. If output 2 is not used for cooling (that is COOL is not selected for OUT2), then PL2 is hidden. If the controller is used for ON-OFF control, then both PL1 and PL2 are hidden

Example:

OUT2=COOL, PB1=10.0°C, CPB=50, PL1=50, PL2=80 the output 1 and output 2 will act as following curves

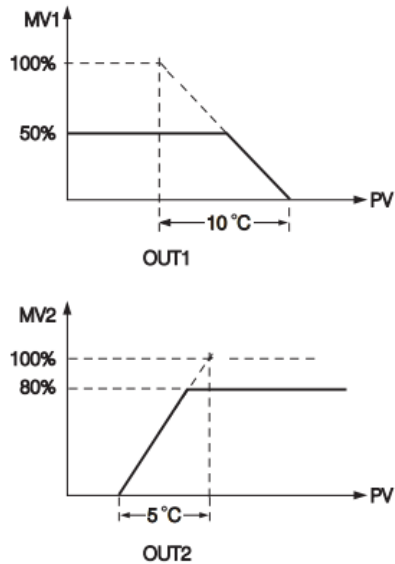

NOTE:

The adjusting ranges of MV1 (H) and MV2 (C) for manual control and/or failure transfer are not limited by PL1 and PL2.

5.2.4.20 Digital Filter

In certain application the process value is too unstable to be read. To improve this, a programmable low pass filter incorporated in this Process Control Card can be used. This is a first order filter with time constant specified by FILT parameter which is contained in setup menu. The default value of FILT is 0.5 sec. before shipping. Adjust FILT to change the time constant from 0 to 60 seconds. 0 second represents no filter is applied to the input signal. The filter is characterized by the following diagram.

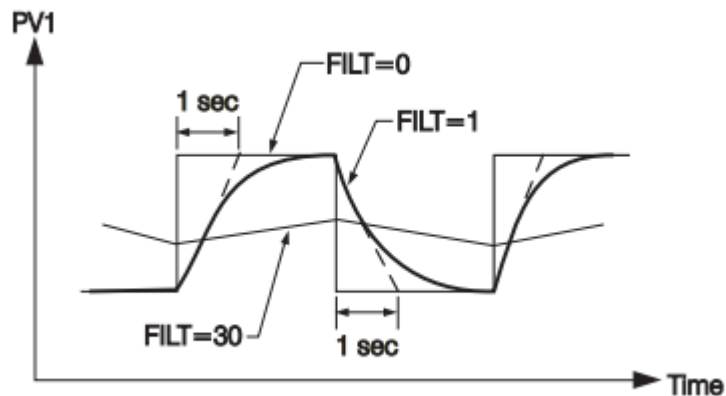

Note

The Filter is available only for PV1, and is performed for the displayed value only. The controller is designed to use unfiltered signal for control even if Filter is applied. A lagged (filtered) signal, if used for control, may produce an unstable process.

5.2.4.21 Auto-Tuning and Manual Tuning

The Auto-tuning and Manual tuning can be executed by pressing the mode key in the Process control module real-time display page. Press  and Press Real Time and Press C1 to access the Process Control module C1 real time display page. In similar way the real time pages of other process control modules also can be accessed.

Press Mode and select Auto-tuning to perform auto tuning for the process. During Auto-tuning process the PV display will blink continuously.

Press Mode and select Manual control to perform manual tuning for the process. In this the user can control the process manually by adjusting the output value manually.
Press Back to exit auto tuning or manual tuning when it is in progress.

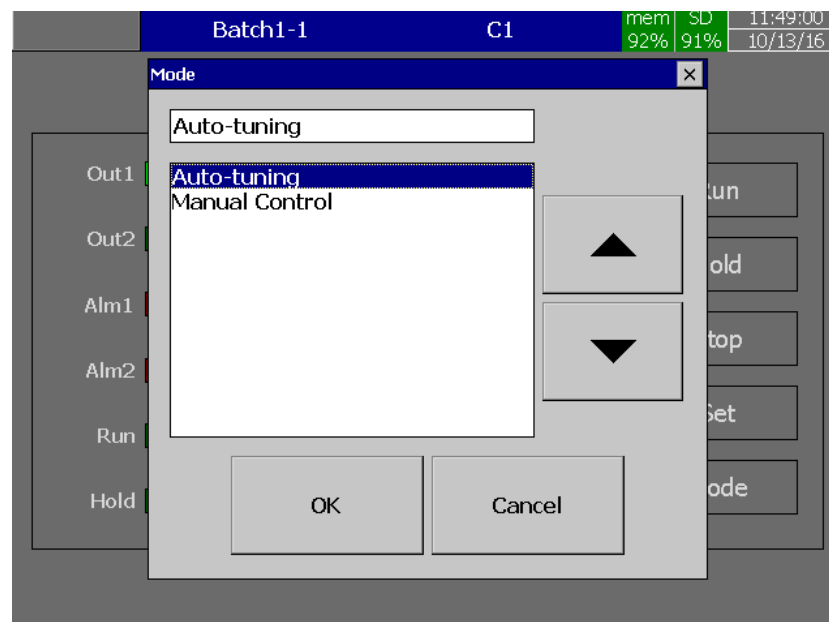
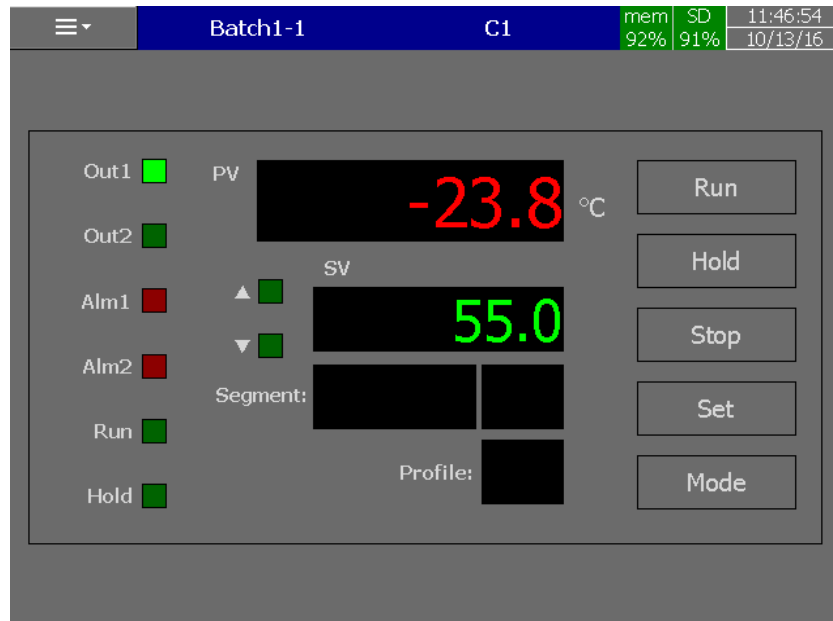

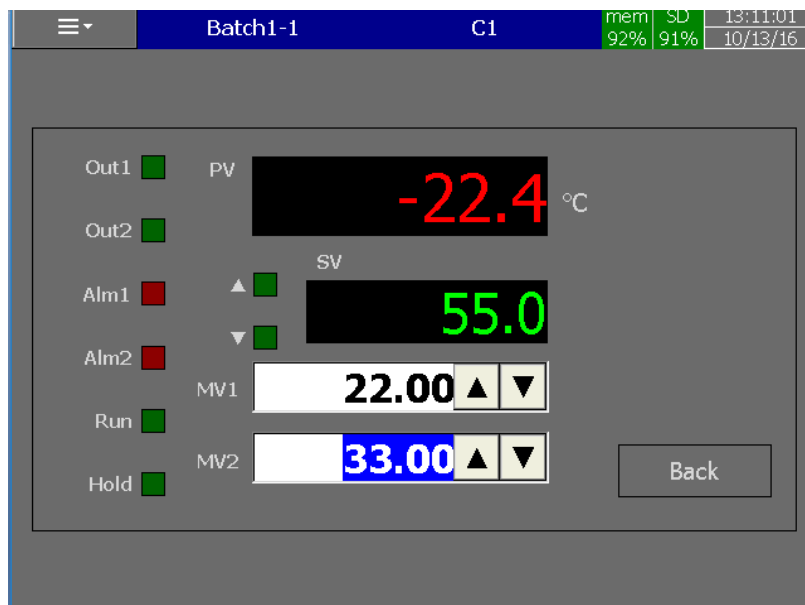



5.2.5 Profile

This will allow the user to configure the ramp and soak profiles for PID process control card. The recorder can be configured with maximum of 50 profiles with each 32 segments limited to 1000 segments in total.

After entering the Configuration menu, select Profile, then Press the “**Enter**” soft key to get into Profile configuration menu. It displays the Profile **Profile1** as the first Profile configuration page. Press

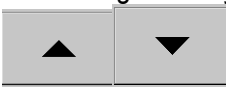
directional navigation keys  at the bottom to select other profiles. Press directional

keys  on the right hand side to select the configuration menu column. After completing

Configuration, press  soft key, then press  soft key to return to main display. All configurations will be saved automatically.

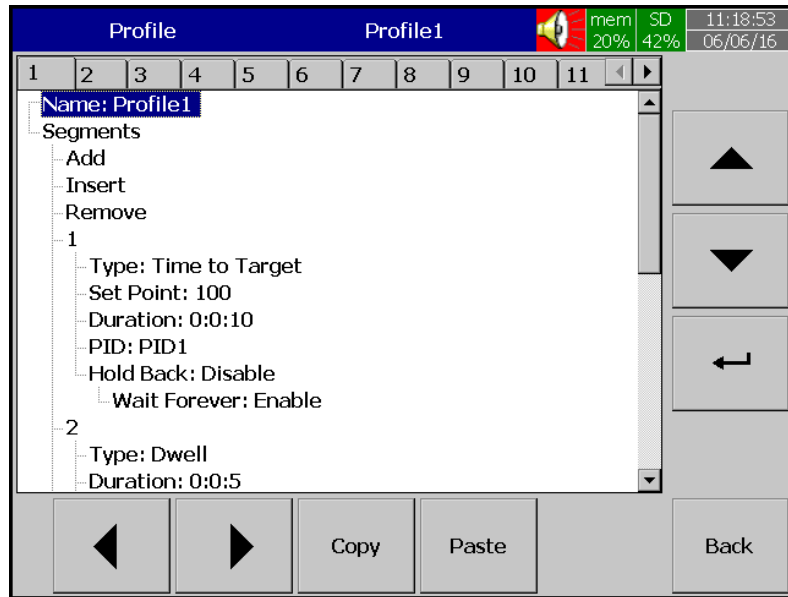

5.2.5.1 Ramp & Dwell

Many applications need to vary temperature or process value with time. Such applications need a controller which varies a set point as a function of time. This Process Control Process Control Card can do this. The set point is varied by using a set point profiler. The profile is stored as a series of “ramp” and “dwell” segments, as shown below.

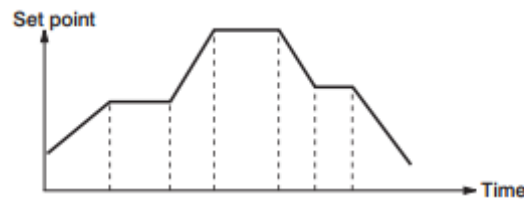

In each segment you can define the state of up to 3 event outputs which can drive either relay, logic or Triac outputs, depending on the modules installed. A profile is executed either once, repeated a set number of times or repeated continuously. If repeated a set number of times, then the number of cycles must be specified as part of the profile.

The below are the available types of segment

5.2.5.1.1 Ramp

Ramp to a new set point at a set rate or in a set time

5.2.5.1.2 Time to Target

Ramp to a segment with a Set point in a set time.

5.2.5.1.3 Dwell

Dwell for a set time

5.2.5.1.4 Go Back

Jump to a specified segment in the same profile

5.2.5.1.5 End

Make this segment the end of the profile

The below four kinds of combination are allowable for connecting segments.

Ramp-Ramp
Ramp-Dwell
Dwell-Ramp
Dwell-Dwell

5.2.5.2 Name

Enable the user to define the name for each Profile with the maximum limit of 18 Characters. Select "Name", then Press "Enter", soft key, a keyboard with several keys appears. Press "Shift" to select special characters. Press "Caps" to select capital letters. Press soft key "OK" after entering a new Profile name.

5.2.5.3 Segments

The user can **add** or **Insert** or **Remove** the segments of the Profile in this section. Press Add and then press Enter Soft key to access the Segment Configuration window.

5.2.5.3.1 Type

Select the Segment type. The Available segment types are as below.

- 1 Ramp
- 2 Time to Target
- 3 Dwell
- 4 Go Back
- 5 End

5.2.5.3.1.1 Ramp Segment Parameters

```
2
Type: Ramp
Condition: Ramp and Setpoint
  Rate: /Sec
    Value: 10
  Set Point: 100
PID: PID1
Hold Back: Disable
```

```
2
Type: Ramp
Condition: Ramp and Time
  Rate: /Sec
    Value: 10
  Duration: 0:0:1
PID: PID1
Hold Back: Disable
```

Condition

The condition to be selected for Ramp Segment to follow to reach set point as **Ramp and Set point** or **Ramp and Time**. The **Ramp and Set point** will change the set point to reach the Set point in that segment in the Ramp Rate specified. The **Ramp and Time** will change the Set point based on the ramp rate specified for the duration mentioned.

Rate

Ramp Rate of the segment to reach the set point .The **Ramp Rate** unit can be set for /Sec./Min./Hour. The **Ramp Rate Value** can be defined in value.

Duration

Duration of the segment for the Ramp can be set in Hour: Minute: Second.

PID

The PID Values to be used for this RAMP is PID1 or PID2.

Hold Back

As the set point ramps up or down (or dwells), the measured value may lag behind or deviate from the set point by an undesirable amount. "Holdback" is available to freeze the profile at its current state. The action of Holdback is the same as a deviation alarm. It can be enabled or disabled. Holdback has three parameters.

- 1 **Holdback wait time**
- 2 **Holdback band**
- 3 **Holdback type**

If the error from the set point exceeds the set holdback band (Band), then if the holdback feature is enabled it will automatically freeze the profile at its current point. At the same time, the holdback timer begins to count. When the value of holdback timer exceeds the value of holdback wait time (wait time), the profiler will no longer be freeze and jump to its next segment, at the same time an error code HBER will be displayed. If the error comes within the holdback band (Band), then the program will resume normal running.

Hold Back Types

There are four different Holdback types. The choice of type is made by setting Holdback parameter when creating a profile with any one of the following

- 1 **OFF** - Disables Holdback - no action is taken.
- 2 **Deviation Lo** - Deviation Low Holdback holds the profile back when the process value deviates below the set point by more than the holdback band (Band).
- 3 **Deviation High** - Deviation high holdback holds the profile back when the process value deviates above the set point by more than the holdback band (Band).
- 4 **Deviation Lo/High** - Deviation Lo/High Holdback is a combination of the two. It holds the profile back when the process value deviates either above or below the set point by more than the holdback band (Band).

Hold Back Action

Holdback action is defined by the below parameters.

- 1 Wait Forever
- 2 Wait Time

If **wait forever is enabled** then process will wait until the PV is come within Holdback band (Band). If **wait forever is disabled** then the holdback action specified in **Action after a timeout** will be finished after the time specified in **wait time**. The available holdback actions are **Hold** and **Continue**. Hold will hold the segment and continue will move to the next segment.

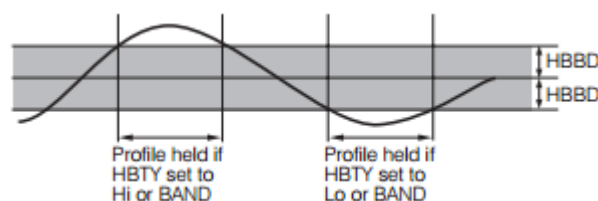

5-13 Holdback on Dwell

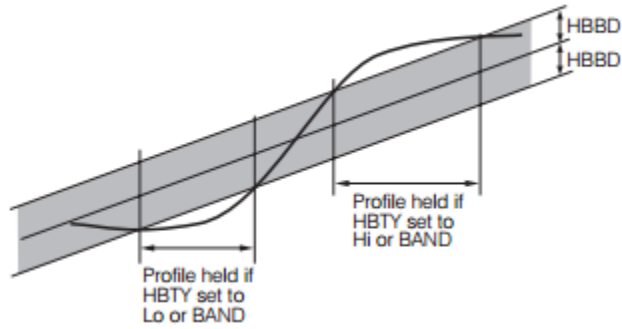

5-14 Holdback on Positive Ramp

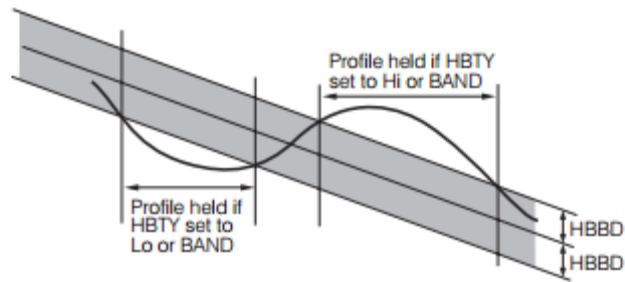

5-15 Holdback on Negative Ramp

5.2.5.3.1.2 Dwell Segment Parameters

```

4
Type: Dwell
Duration: 0:0:5
PID: PID1

```

Duration

Duration of the segment for the Dwell can be set in Hour: Minute: Second.

PID

The PID Values to be used for this Dwell is PID1 or PID2.

5.2.5.3.1.3 Go Back Segment Parameters

```

4
Type: Go Back
PID: PID1
Segment: 1
Cycle: 1

```

This segment will jump to the specified in the segment mentioned on the **Segment** for the no of cycles mentioned in **Cycle**.

5.2.5.3.1.4 End Segment Parameters

```
4
├── Type: End
├── Set Point: 0
└── PID: PID1
```

This is an End segment of the profile to End the profile with set point mentioned in Set Point with the PID values in the selection of PID1 or PID2 as per the selection.

5.2.5.3.1.5 Time to Target Segment Parameters

```
4
├── Type: Time to Target
├── Set Point: 0
├── Duration: 0:0:5
├── PID: PID1
├── Hold Back: Disable
└── Wait Forever: Enable
```

This is similar to ramp segment with automatic calculation of ramp rate by the Process Control Card with the reference of Set point and duration given by the user.

Set Point

Set Point to be reached in this segment. Of the segment

Duration

Duration of the segment to reach the set point

PID

The PID Values to be used for this RAMP is PID1 or PID2.

Holdback

Hold back actions to be enable or not. Refer the details in Ramp segment section for detailed explanation.

5.2.5.4 Jobs

The job is called as a task to be performed when the event is activated. There are two jobs Start Job and End Job can be added to perform any event.

A typical example is to trigger **an alarm buzzer** in the event of a high temperature.

Note: Please refer to the section [Jobs](#) for full details about various jobs available

5.2.5.4.1 Start/End Jobs

```
├── Jobs
│   ├── Start: No Action
│   └── End: No Action
```

Start: Define the job to be done at the start of the Profile (Ramp & Dwell)

End: Define the job to be done at the End of the Profile (Ramp & Dwell)

5.2.5.5 Start/Stop Profile (Ramp & Dwell)

The Profile can be start, Hold or stop from the Real time display page of process control module. The Profile can be selected and run from the Run button on the display page. Press **Run** and select the profile to be run then press ok to start the Profile.

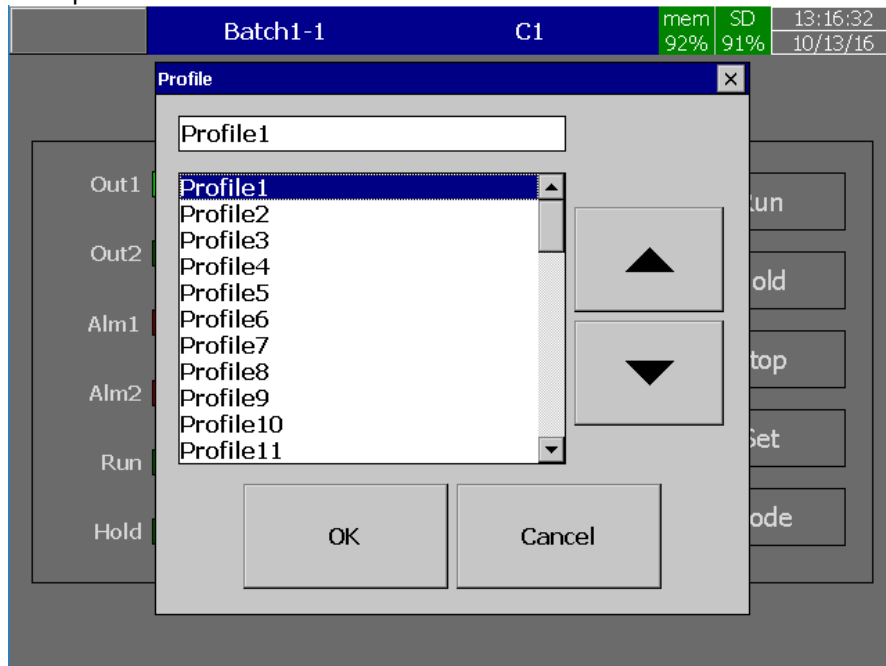

Press **Hold** to hold the profile. Press **Stop** to stop the Profile.

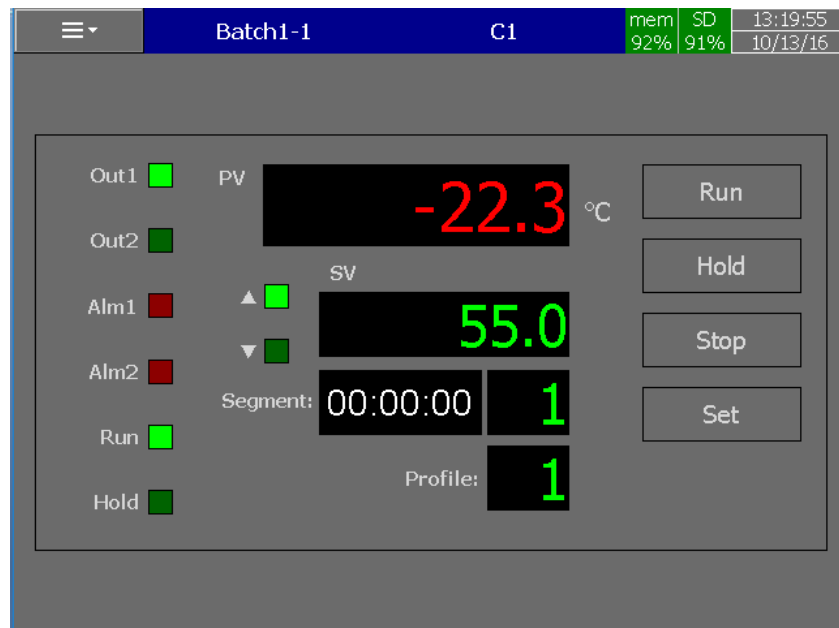

The real time display page will show the Profile and Segment no along with the remaining time of that particular segment.

5.2.5.6 Oven Control with Zone Temperature Recording Application

An Oven is designed to dry the products with 6 zones. The Zone Temperature is controlled by a single temperature controller. The temperatures of the different zones are recorded to ensure the operation of different zones. Generally for this application one temperature controller and 6 channel recorder are required. By using PPS series Recorder with PID Control card it can be achieved with one device. The oven required to dry the products at 500°C for 1 hour. All the 6 zones temperature needs to be recorded. For this dwell timer of PID Control card needs to be used for control the oven temperature and Analog inputs of Recorder needs to be connected with Thermocouple inputs from all the zones. The system configuration is as below.

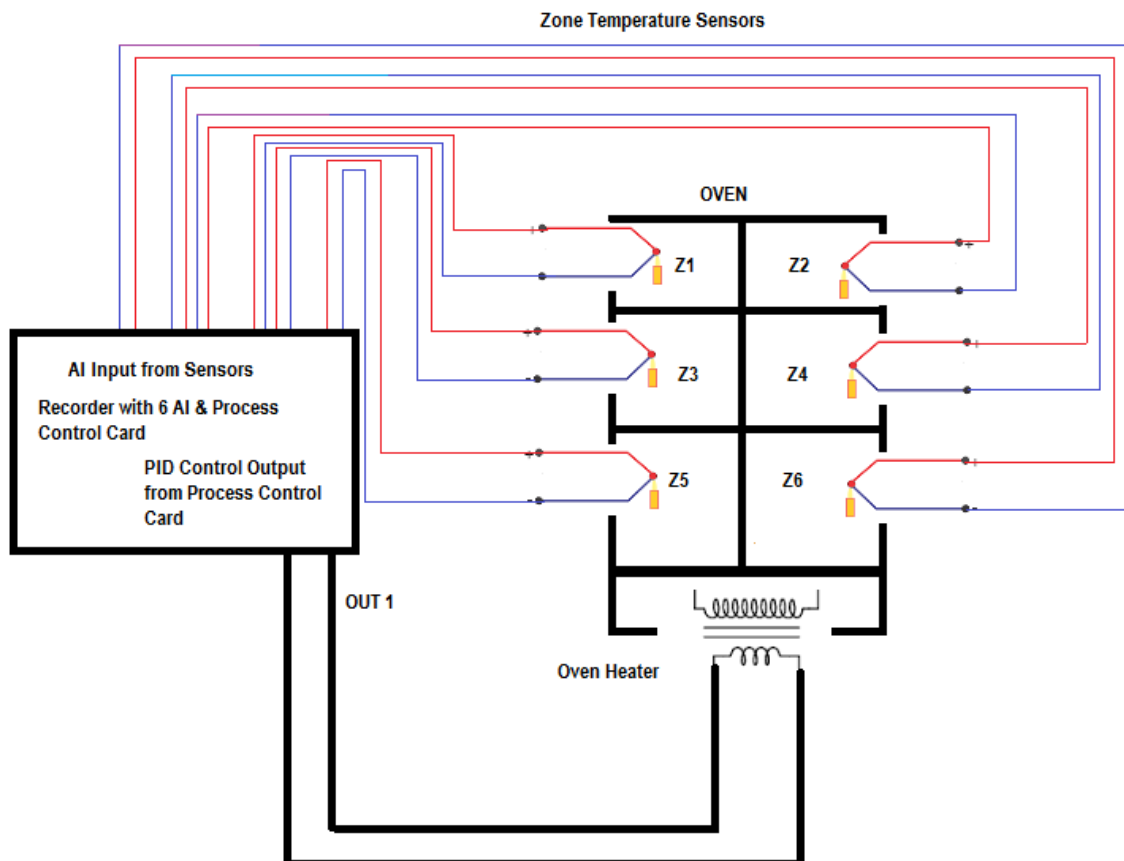

To achieve this function set the following parameters in the PID Control setup menu and configure the Recorder as per the recording requirements.

FUNC=BASC (Basic function)

IN1=K_TC

IN1U= C

DP1=1_DP

OUT1=REVR

O1TY=RELY

CYC1=18.0

O1FT=BPLS

A1FN=TIMR

A1FT=ON

SELF=NONE

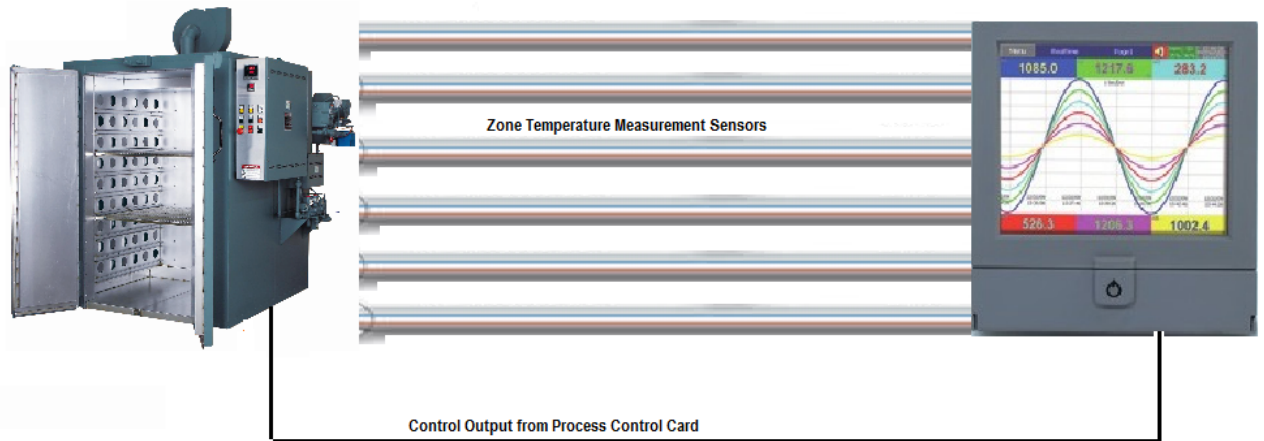

5.3 Jobs

There are various types of jobs available in the recorder to activate by an event. The available jobs are listed as below.

5.3.1 No Action

Do nothing

5.3.2 Send Email

Send Email directly from Recorder

5.3.3 Pause

Stop logging data.

5.3.4 Start

Start logging data.

5.3.5 Sound Buzzer

Sound the buzzer. It stops once any key is pressed.

5.3.6 Dump Data

Dump the historical data from internal memory to external memory such as SD Card or USB Disk. The user can select the data to be dumped to external memory.

5.3.7 DO Latch On

Set digital output / relay on, and then select Target, let's say from one of DO 1 to DO 6. The relay is latched when it is activated.

5.3.8 DO Latch Off

Set digital output / relay off, and then select Target, let's say from one of DO 1 to DO 6. The relay is un-latched when it is activated.

5.3.9 DO Process

Set digital output / relay on for process high or low, and then select the target, let's say from 1 of DO 1 to DO 6. The relay is not going to be latched when it is activated.

5.3.10 Enable Timer

Start the timer, and then select Target timers

5.3.11 Disable Timer

Stop the timer, and then select Target from Timers

5.3.12 Preset Totalizer

Set a pre-set value to the target Totalizer.

5.3.13 Reset Totalizer

Reset Totalizer to zero. Select a single Target Totalizer or All totalizers

5.3.14 Enable Totalizer

Starts the Totalizer. Select a single Target Totalizer or All totalizers

5.3.15 Disable Totalizer

Stops the Totalizer. Select a single Target Totalizer or All totalizers

5.3.16 Preset Counter

Set a pre-set value to the target counter.

5.3.17 Reset Counter

Resets the counter to zero. Select a single Target counter or all counters

5.3.18 Inc Counter

Increases the counter by 1. Select a Target counter or all counters

5.3.19 Dec Counter

Decreases the counter by 1. Select a Target counter or all counters

5.3.20 Log Report

Log a report for the selected channels. The options available to select for the report are Counter, Totalizer, Analog inputs (Min/Max/Avg), Math (Min/Max/Avg), All Counters, All Totalizers, and All Channels (Min/Max/Avg).

5.3.21 Reset MinMaxAve

Reset the minimum, maximum and average values of the previously sampled data. The statistical data will calculate from the new sample of reports.

5.3.22 Print Historical data

Prints the historical data. The period of data to be printed will follows the configuration in Auto output menu.

5.3.23 Print Event List

Prints the historical event list. The period of data to be printed will follows the configuration in Auto output menu.

5.3.24 Print Report List

Prints the historical data of log report data. The period of data to be printed will follows the configuration in Auto output menu.

5.3.25 Print Snapshot

Prints the snapshot of the screen.

5.3.26 Output Historical Data

This will generate a historical data output in CSV format in external storage. It will also contains event reports.

5.3.27 Copy Value and Paste Value

This is mainly used for retransmission of Analog inputs using external (communication) Analog output channels. Since we have limitation of Analog outputs on the Recorder. This external channels can be used by using the copy value and paste value. This can be used by using event or timer when job 1 is copy value, job2 will be paste value.

5.3.28 Select Controller

Select the PID Process controller card

5.3.29 Run Profile

Select the profile to run.

5.4 Display



This will allow the user to configure the real time display pages on the recorder. The maximum no of display pages and pens per display page will vary depends on the recorder model no.

	PPS-1000	PPS-2000	PPS-3000
Display pages	8	20	21
Pens/Page	6	6	10

After entering the Configuration menu, select “**Display**” then Press the “**Enter**” key to get into Display configuration menu. It displays the Display page **Page1** as the first display page configuration page.

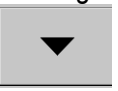
Press directional navigation keys   at the bottom to select other pages. Press directional

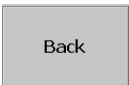
keys   on the right hand side to select the menu column. After completing Configuration,

press  soft key, then press  soft key to return to main display. All configurations will be saved automatically.

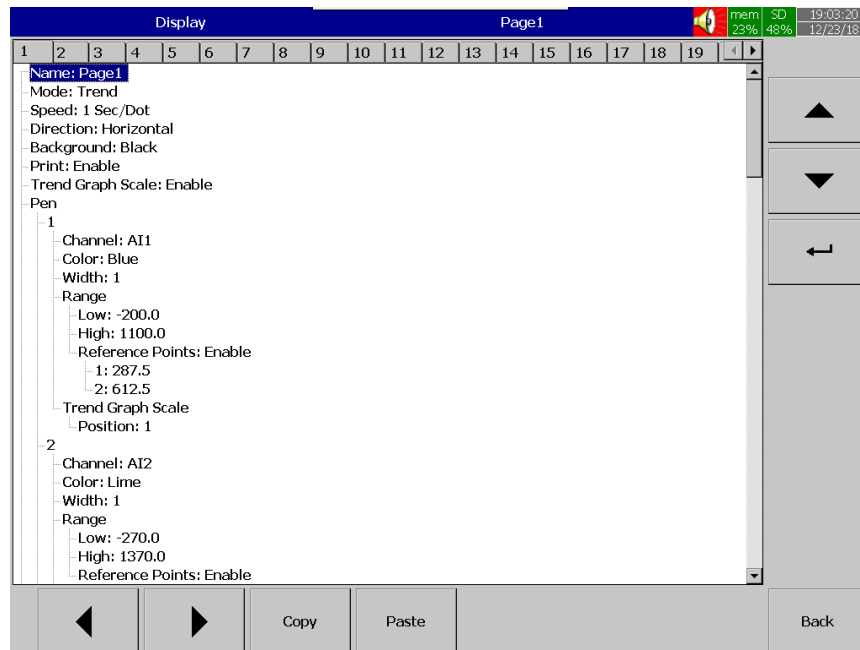

Copy: copy the configuration from one page to another page.

Paste: Paste the copied configuration to the page.

Press Copy key in the source page and press paste key in the destination page.

5.4.1 Name

Enables the User to define the name for each page with a maximum of 18 characters.

Select "Name", then Press "Enter", soft key, a keyboard with several keys will appear. Press "Shift" to select special characters. Press "Caps" to select capital letters. Press soft key "OK" after entering a new display page name.

5.4.2 Mode

Defines the default mode of displaying data for the page. The available options are Trend, Bar, Digital, Mix, Circular, Individual and Disable modes.

Note: Circular Trend mode is available only in PPS-3000.

5.4.3 Speed

This is the display speed. The available display speeds are as below.

1. 100 msec/dot
2. 1 Sec/dot
3. 2 Sec/dot
4. 5 Sec/dot
5. 10 Sec/dot
6. 15 Sec/dot
7. 20 Sec/dot
8. 30 Sec/dot
9. 1 min/dot
10. 2 min/dot
11. 5 min/dot
12. 15 min/dot
13. 10 min/page (Circular Mode only)
14. 30 min/page (Circular Mode only)
15. 1 hour/page (Circular Mode only)
16. 2 hour/page (Circular Mode only)

- 17. 4 hour/page (Circular Mode only)
- 18. 8 hour/page (Circular Mode only)
- 19. 12 hour/page (Circular Mode only)
- 20. 1 day/page (Circular Mode only)
- 21. 2 day/page (Circular Mode only)
- 22. 1 week/page (Circular Mode only)
- 23. 2 week/page (Circular Mode only)
- 24. 4 week/page (Circular Mode only)
- 25. 1 hour/dot
- 26. 2 hour/dot

5.4.4 Direction

Sets the trend direction to be horizontal or vertical.

5.4.5 Background

Sets the background colour of Trend to black or white

5.4.6 Print Enable

This will enable or disable the data of the configured pen on this page in print Historical data and output historical data jobs.

5.4.7 Trend Graph Scale

The trend scale of the pens to be enabled or disabled in the display page.

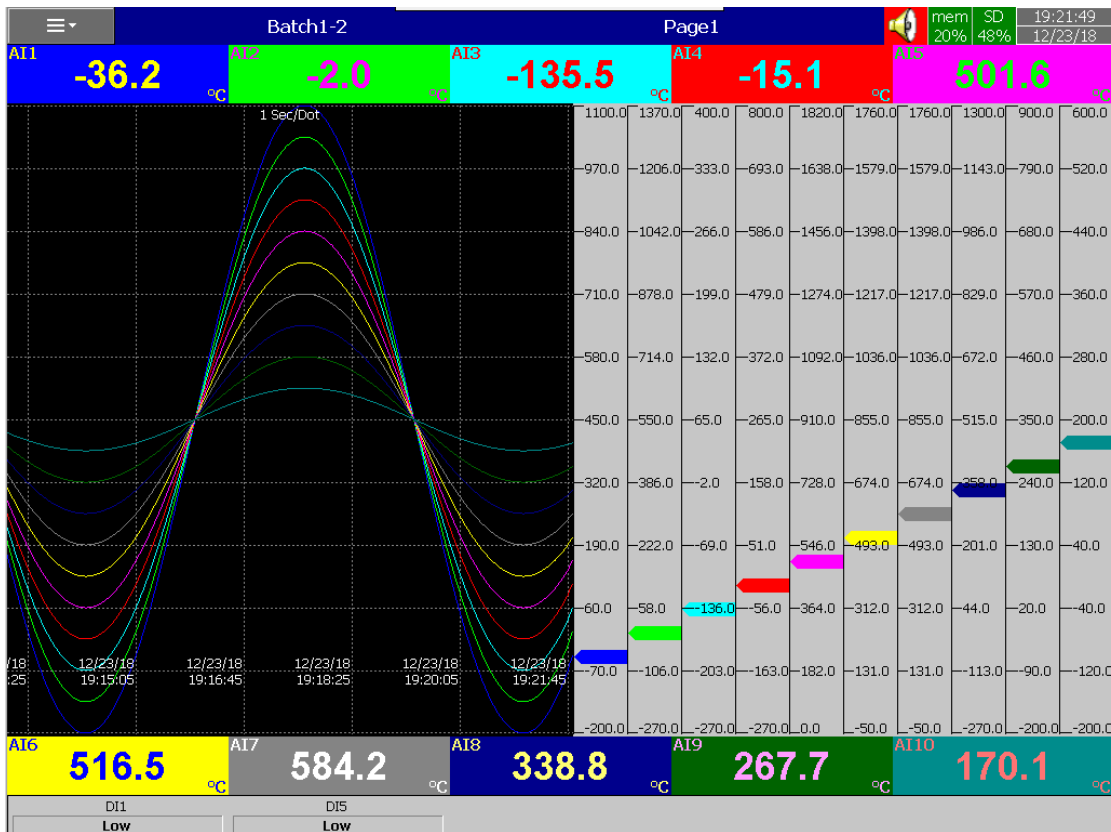

5-16 Trend Scale

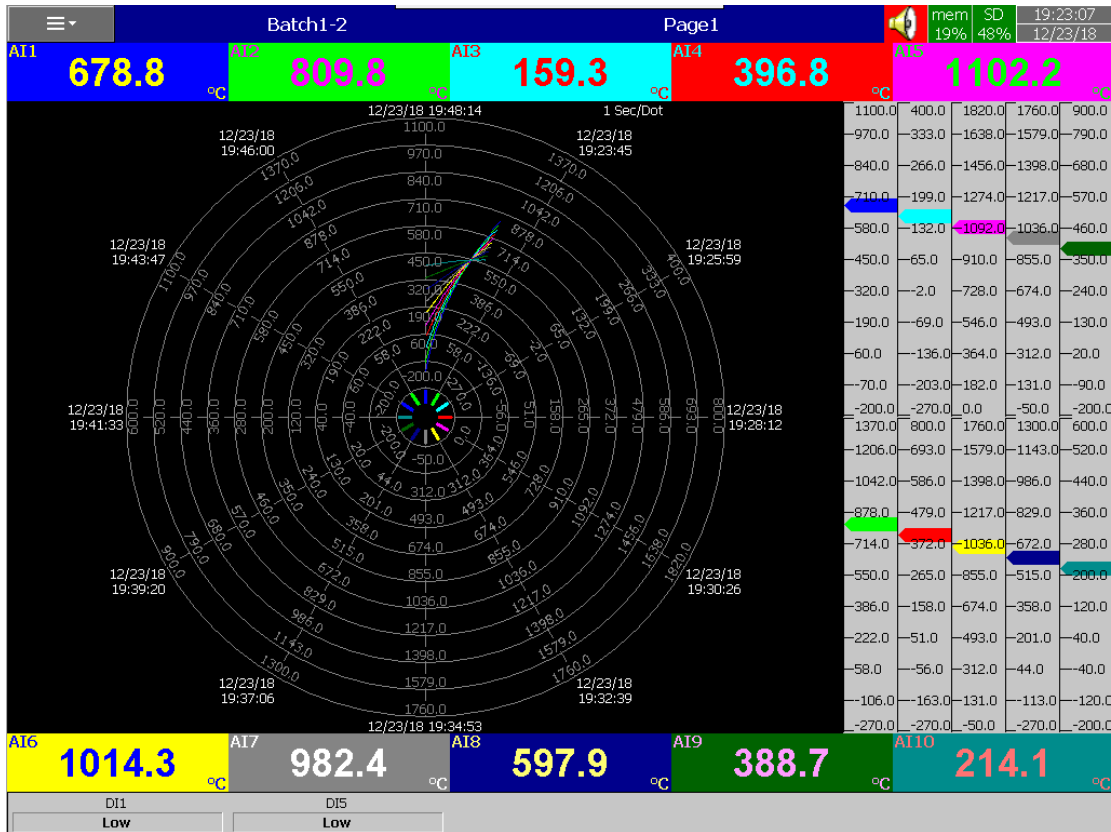

5-17 Circular Scale

5.4.8 Pen

This will configure the display pens of that display page and their properties.

5.4.8.1 Channel

Selects a specific channel for that pen from analog input, Math, Counter, Totalizer, External Channels. Select disable if a specific pen is not required to display any channels.

5.4.8.2 Color

Selects the colour for that pen.

5.4.8.3 Width

Selects the width of that pen. The available options are 1, 2, and 3.

5.4.8.4 Range Low

Defines the low scale for that pen on the display.

5.4.8.5 Range High

Defines the high scale for that pen on the display.

5.4.8.6 Reference points

This will draw two reference points on the display. This will be displayed only in individual mode, in trend mode with only one pen per page and in circular mode with only one pen per page. The reference points has two points 1 & 2 to configure when it is enabled. It will not be displayed when it is disabled.

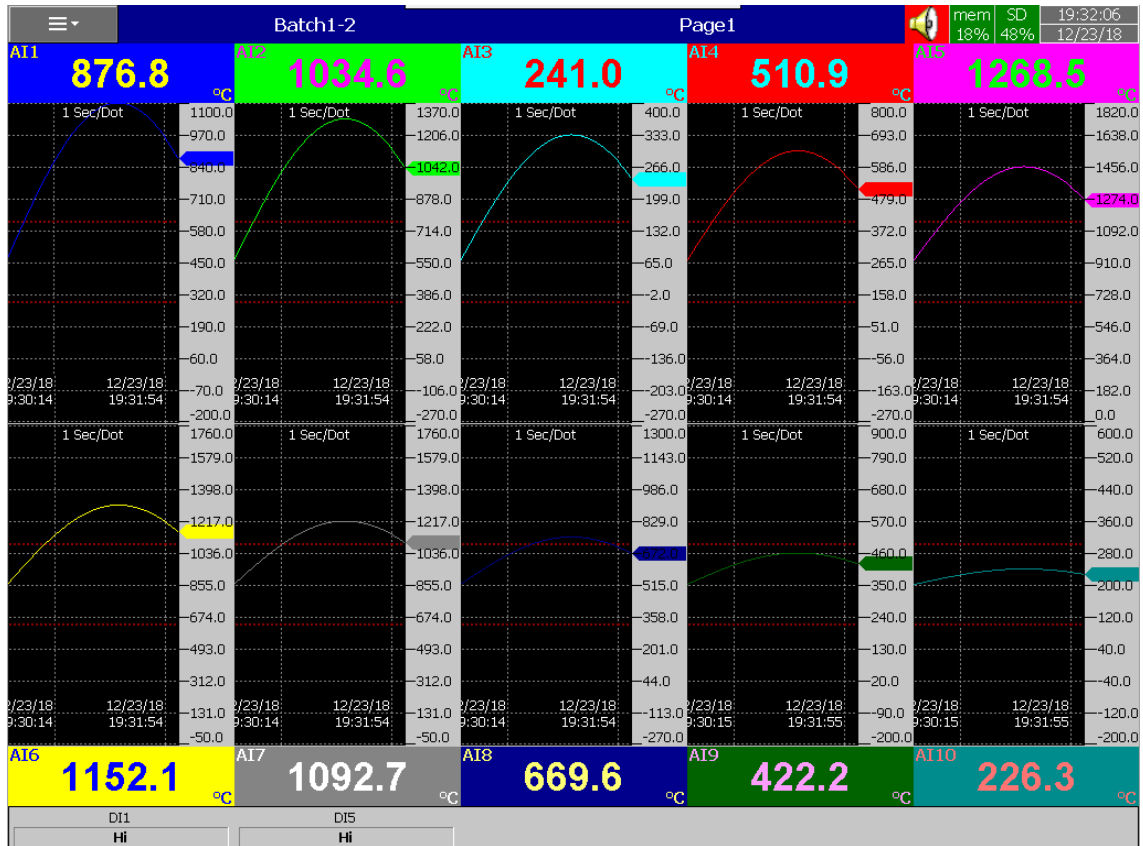

5-18 Reference Points Display

5.4.8.7 Trend Graph scale position

The position of the trend scale from left to right of that pen in display page. The scale can be disabled by selecting disable in the position.

Note

- ❖ To illustrate the difference between Display Hi, Display Lo, Scale Hi, and Scale Low, here is a typical example, with input 0-10V, Scale Low=0.00, Scale Hi=100.00, to have better resolution and vision on Bar graph, set the Display Lo=0.00 and Display Hi=50.00 so that the Bar displays from value 0.00 to 50.00.
- ❖ The decimal point is defined by Scale Hi and Scale Low, and not by Display Hi, or Display Lo.

5.4.8.8 Status Bar

To make it convenient when viewing the status of Digital Input, Digital Output, Math channel, Totalizer, Counter and AO, the user may enable these items in the status bar. The Status bar is displayed at Lower part of the display page. One status bar can be configured for each page. Each status bar consists of 6 tags in PPS-1000 and PPS-2000 and 10 tags in PPS-3000 for the user configuration.

Note

Status bar configuration is not shared in all the pages. You may define a different setup for status bars in each page per your requirements.

Display Page1

mem 14% SD 48% 19:48:44 12/23/18

1 2 3 4 5 6 7 8 9 10 11 12 13 14 15 16 17 18 19

- 1: 212.5
- 2: 487.5
- Trend Graph Scale
- Position: 9
- 10
- Channel: AI10
- Color: Dark Cyan
- Width: 1
- Range
- Low: -200.0
- High: 600.0
- Reference Points: Enable
- 1: 100.0
- 2: 300.0
- Trend Graph Scale
- Position: 10

Status Bar



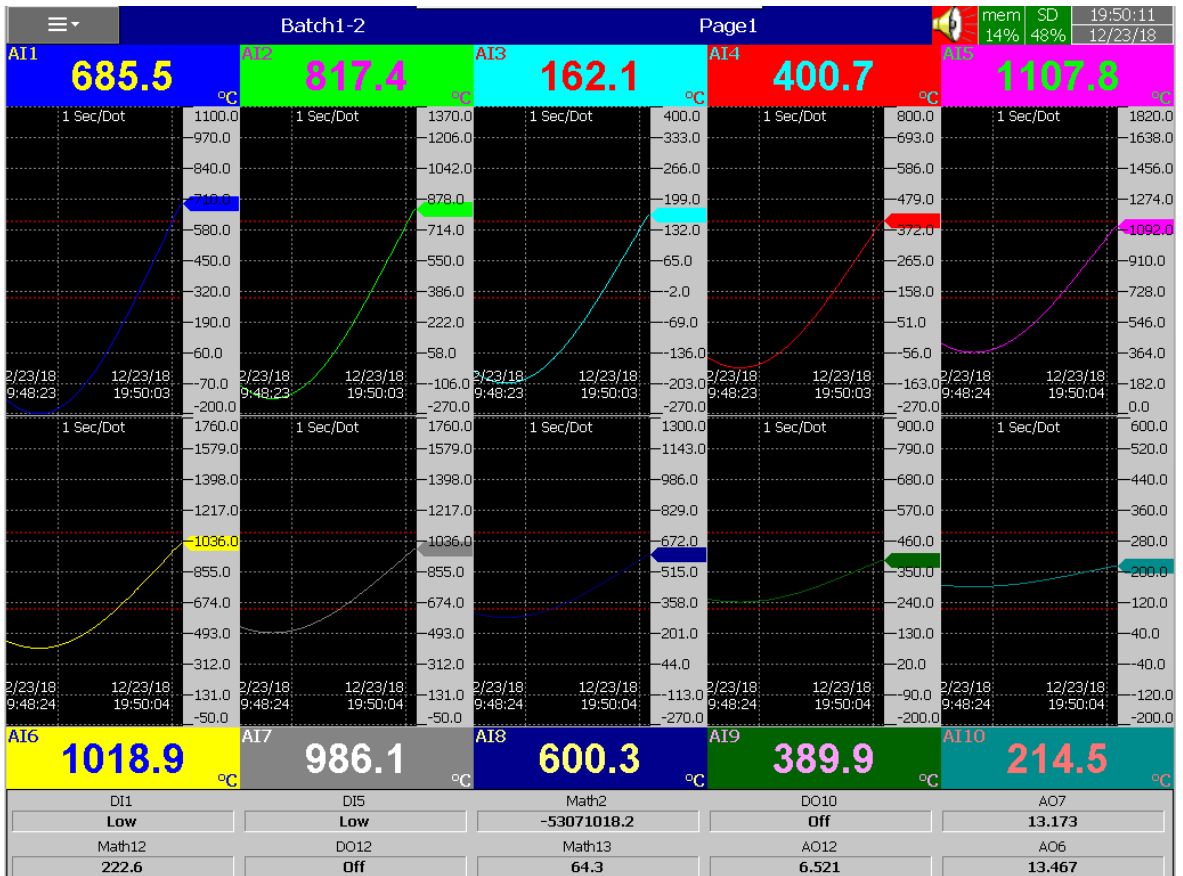

- Type: Enable
- 1: DI1
- 2: DI5
- 3: Math2
- 4: DO10
- 5: AO7
- 6: Math12
- 7: DO12
- 8: Math13
- 9: AO12
- 10: AO6

Copy Paste Back



5.5 Batch

This will allow the user to configure the batch configuration. This menu will be visible to the user when batch is enable in instrument menu configuration. After entering the Configuration menu, select **"Batch"** then Press the **"Enter"** key to get into Batch configuration menu. It displays the Display page

Page1 as the first display page configuration page. Press directional keys   on the right hand side to select the menu column. After completing Configuration, press  soft key, then press  soft key to return to main display. All configurations will be saved automatically.

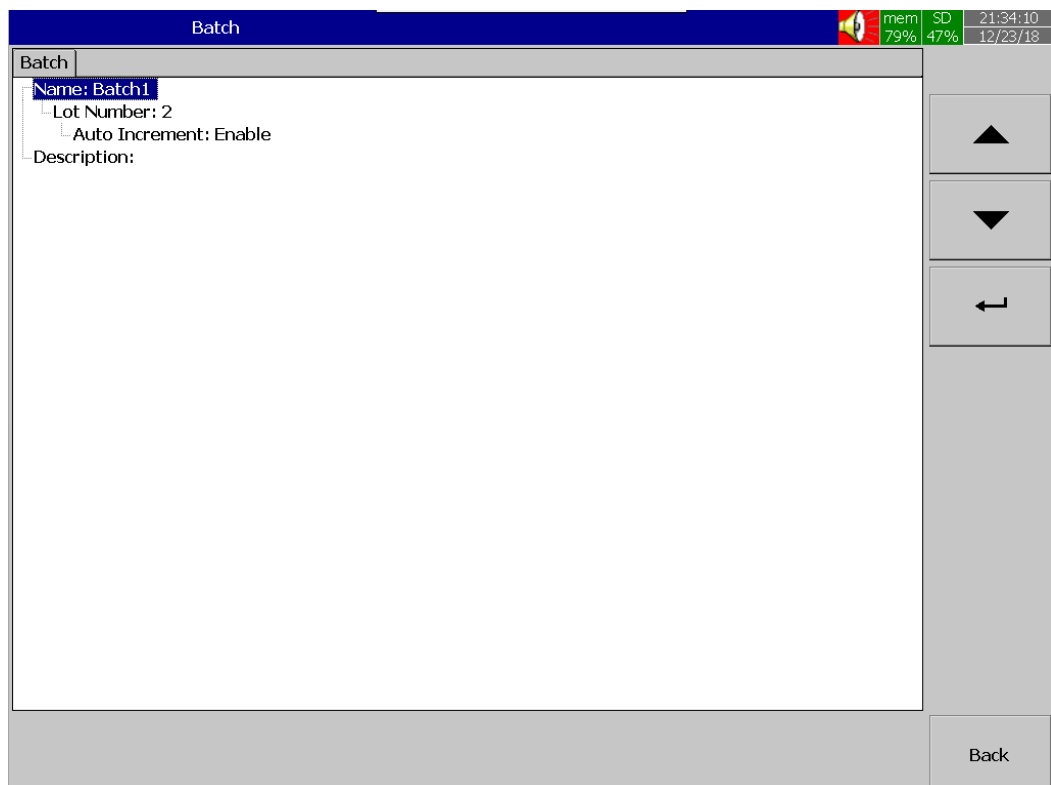

5.5.1 Name

Enables the User to define the name for Batch with a maximum of 18 characters. Select **"Name"**, then Press **"Enter"**, soft key, a keyboard with several keys will appear. Press **"Shift"** to select special characters. Press **"Caps"** to select capital letters. Press soft key **"OK"** after entering a new batch name.

5.5.1.1 Lot Number

Define the starting Lot number of the batch.

5.5.1.1.1 Auto Increment

If this option is enabled then the lot number will be automatically incremented by one for the next batch.

5.5.2 Desc

The description about the batch for logging.

5.5.3 Example for Batch Application

The operator wants to start a batch every day at 8.00am and stop the batch at 12.00am.

Configuration

Timer1

Type: Daily

Action: Enable

Time – Hour: 8 Min: 0 Sec: 1

Job1: Start

Job2: No Action

Timer2

Type: Daily

Action: Enable

Time – Hour: 12 Min: 0 Sec: 1

Job1: Pause

Job2: No Action

5.5.4 How to view batch data in Recorder

1. Press on  (Menu)-History-Page1
2. Press “Search”, select required Batch and press “Ok”
3. Batch details including lot number can be archived by pressing soft key “Batch”

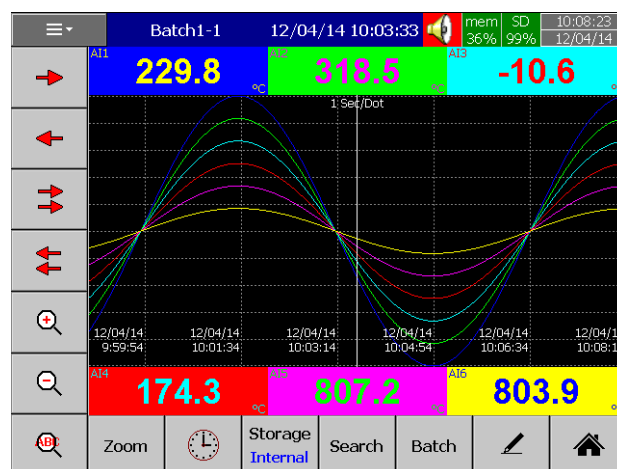
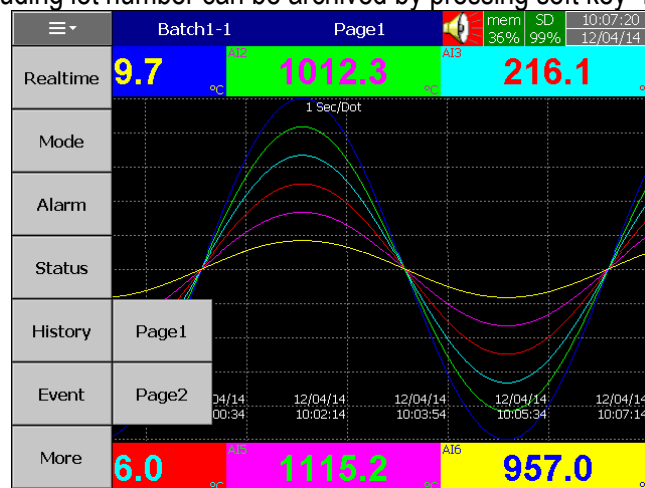

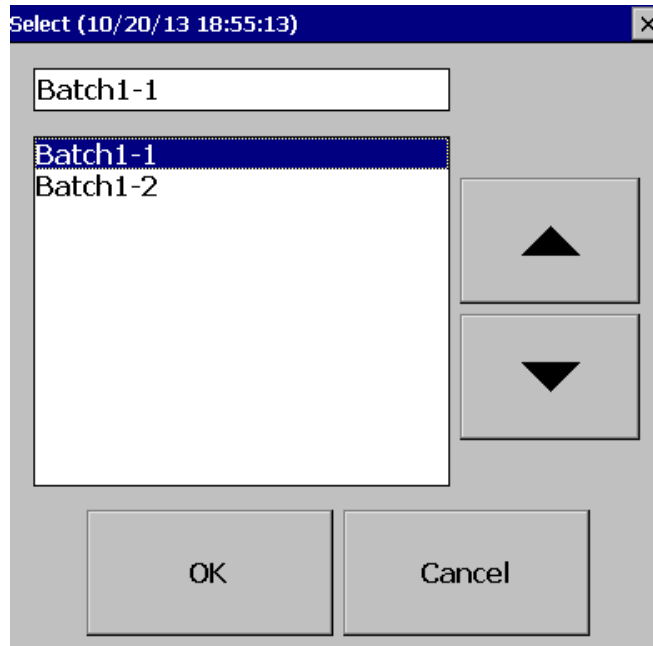

5.5.5 How to Dump Batch data to external USB memory

1. Press on  (Menu)-More then press on Dump

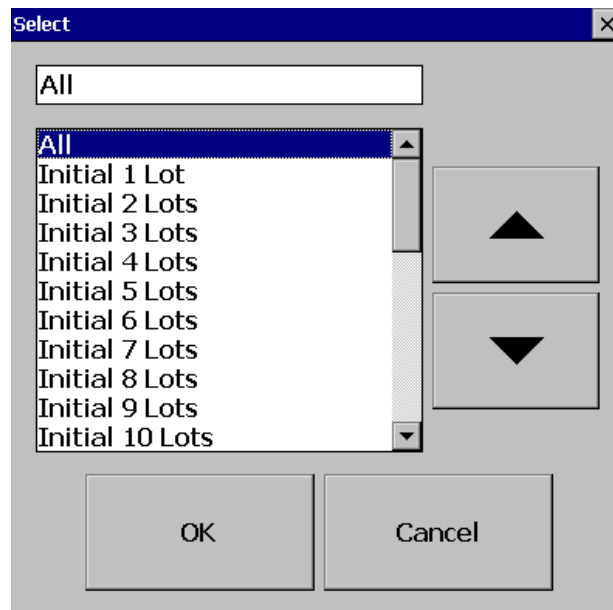

2. Select "All" or required lots and press "OK"
 For example, Batch1-1, Batch 1-2, Batch1-3 are available
 Initial 1 Lot means, Batch1-1
 Initial 2 Lots means, Batch1-1 and Batch1-2
 Initial 3 Lots means, Batch1-1, Batch1-2 and Batch1-3

Note

Provision not available to dump only a specific lot.

3. Press on "Yes" to dump data from internal memory to external SD Card or USB memory.

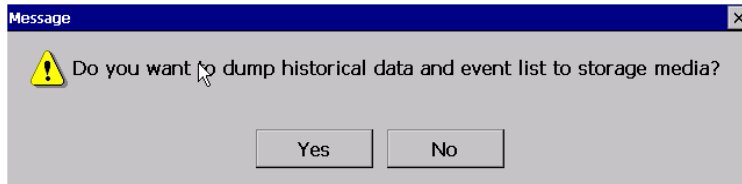

If there are 3 batches, let's say Batch1-1, Batch1-2 and Batch1-3, then there are three different folders in the external storage after completing of dump

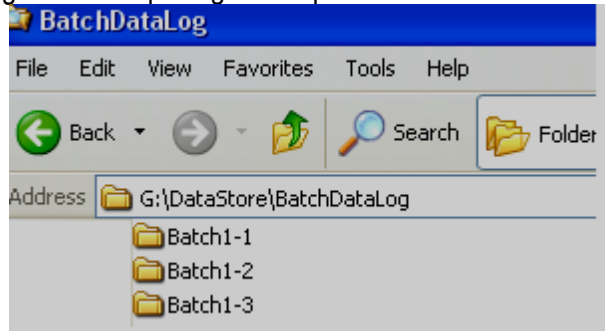

Note

The data available in external memory is in a proprietary format to avoid any kind of tampering. The PC software is required to view this data.

5.6 Start / Stop

This will allow the users to configure the jobs when the logging is started or stopped.

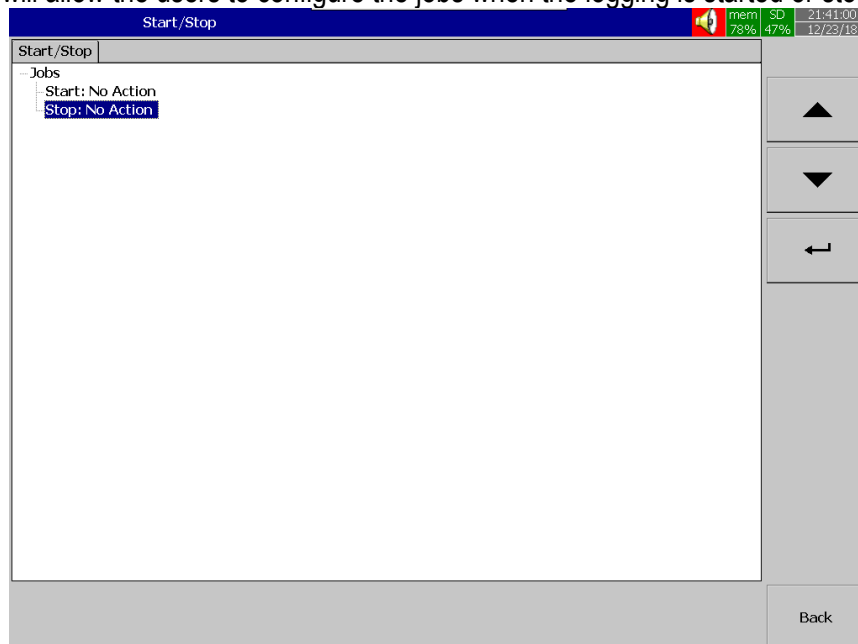

5.6.1 Start

Configure the job for the start action. This job will be activated when the logging is started.

5.6.2 Stop



Configure the job for the stop action. This job will be activated when the logging is paused or stopped.

5.7 Timer



This will allow the user to configure the timers on the recorder. The no of timers available on the recorder will vary depends on the recorder model no. They are listed as below.

	PPS-1000	PPS-2000	PPS-3000
Timer	6	20	48

After entering the Configuration menu, select “Timer” then Press the “Enter” key to get into Timer configuration menu. It displays Timer **Timer1** as the first timer to configure. Press directional

navigation keys   at the bottom to select other timer. Press directional keys 

 on the right hand side to select the menu column. After completing Configuration, press

 soft key, then press  soft key to return to main display. All configurations will be saved automatically.

Copy: copy the configuration from one timer to another timer.

Paste: Paste the copied configuration to the timer.

Press Copy key in the source timer and press paste key in the destination timer.

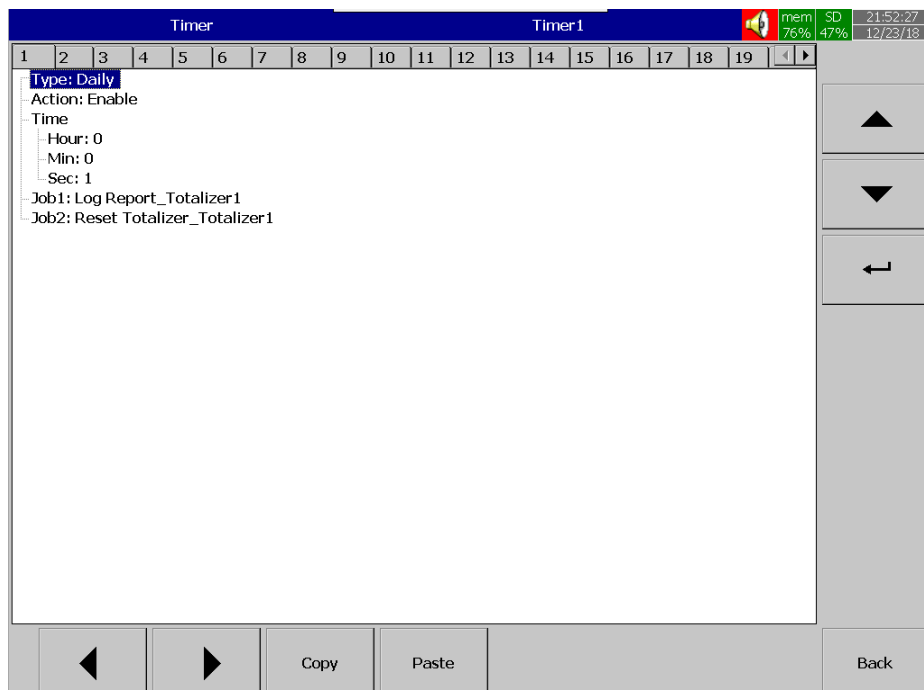

The timers can be used to execute a job on time basis. The timers can be categorized in to Countdown, Repeat Countdown, Daily, Weekly and Monthly.

5.7.1 Type

Select the type of Timer. The available options for the users are as below.

1. Countdown
2. Repeat Countdown
3. Daily
4. Weekly
5. Monthly

5.7.1.1 Countdown

This timer will execute only once and activate the defined jobs after the defined time.

5.7.1.2 Repeat Countdown

This timer will execute in loop continuously and activate the defined jobs in the defined interval of time.

5.7.1.3 Daily

This timer will activate the defined jobs at a defined time every day.

5.7.1.4 Weekly

This timer will activate the defined jobs at a defined time every week.

5.7.1.5 Monthly

This timer will activate the defined jobs at a defined time every month.

Note

Countdown and Repeat countdown timers will not follow RTC clock time. They will start the timer from 0 once they are activated. Daily, Weekly and Monthly timers will follow the RTC Clock time to execute the jobs.

5.7.2 Action

Disables or enables the timer.

5.7.3 Job1, Job2

2 jobs can be configured for each timer.

5.7.4 Timer Example-1

Switch on water pump every day at 8.00am and switch off at 10.00am. This application requires a "Daily" timer which works with Real Time Clock. Configuration settings are as follows.

Timer1

Type: Daily

Action: Enable

Time – Hour: 8 Min: 0 Sec: 0

Job1: DO Latch On, Target: DO1

Job2: No Action

Timer2

Type: Daily

Action: Enable

Time – Hour: 10 Min: 0 Sec: 0

Job1: DO Latch Off, Target: DO1

Job2: No Action

5.7.5 Timer Example-2

Let's say, when a digital input high event is triggered by high pressure, switch on a relay after a 10 seconds delay.

Digital Input1

Event1

Type: H

Job1: Enable Timer, Target: Timer1

Job2: No Action

Event2
 Type: L
 Job1: DO Latch Off, Target: DO1
 Job2: No Action

Timer1

Type: Countdown, Action: Disable
 Time – Hour: 0 Min: 0 Sec: 10
 Job1: DO Latch On, Target: DO1
 Job2: No Action

5.7.5.1 Timer Example-3





The user requires to get a **daily** report from the recorder about the **minimum, maximum and average** values of the process every day. After production has finished, the user can press **Menu**, then **Event**, then selects **Report** and presses the **Mode** key to select the **Daily** mode. It will show the report on daily basis.

Timer1

Type: Daily
 Action: Enable
 Time – Hour: 17 Min: 01
 Job1: Log Report Target: ALL CH MinMaxAve
 Job2: Reset Min/Max/AveTarget: ALL CH
 (Reset historical data in order to logging new data for the next day.)

5.8 Clock

This will allow the user to configure the clock and related configuration including summer saving time adjustment. After entering the Configuration menu, select **Clock** then Press the **Enter** key to get into Clock configuration menu. It displays the clock configuration menu to configure. Press directional keys

  on the right hand side to select the menu column. After completing Configuration, press  soft key, then press  soft key to return to main display. All configurations will be saved automatically.

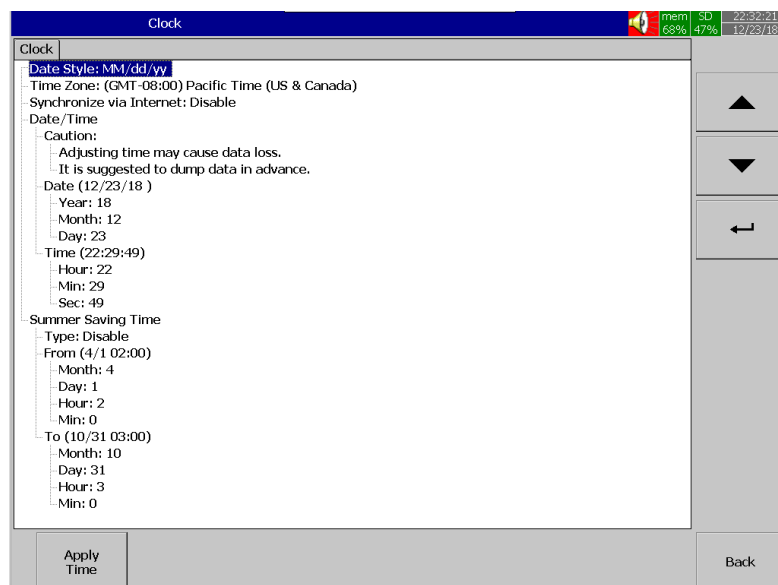

5.8.1 Date Style

Selects the Date style format for the recorder. The available options are MM/dd/yy and dd/MM/yy.

5.8.2 Time Zone

Select the time zone for the recorder

5.8.3 Synchronize via Internet

This will allow the recorder to synchronize the clock time from time server via Internet connection on the recorder. If this option is enabled then the recorder will connect with Time server every day at the defined time to synchronize the clock.

5.8.4 Date / Time





This will allow the user to set the clock manually. After modifying the clock data press  to apply the modified time.

5.8.5 Summer time

In some countries of North America and Europe, clocks are adjusted forward one hour near the start of spring and are adjusted backward in autumn. This is commonly referred to as Daylight Savings Time. Here it is referred as Summer Time. The summer time can be enabled by selecting enable in the Type and configuring From and To time.

5.9 Communication

This will allow the user to configure the communication related parameters. After entering the Configuration menu, select **Communication** then Press the **Enter** key to get into Communication configuration menu. It displays the communication configuration menu to configure. Press directional keys

  on the right hand side to select the menu column. After completing Configuration, press  soft key, then press  soft key to return to main display. All configurations will be saved automatically.

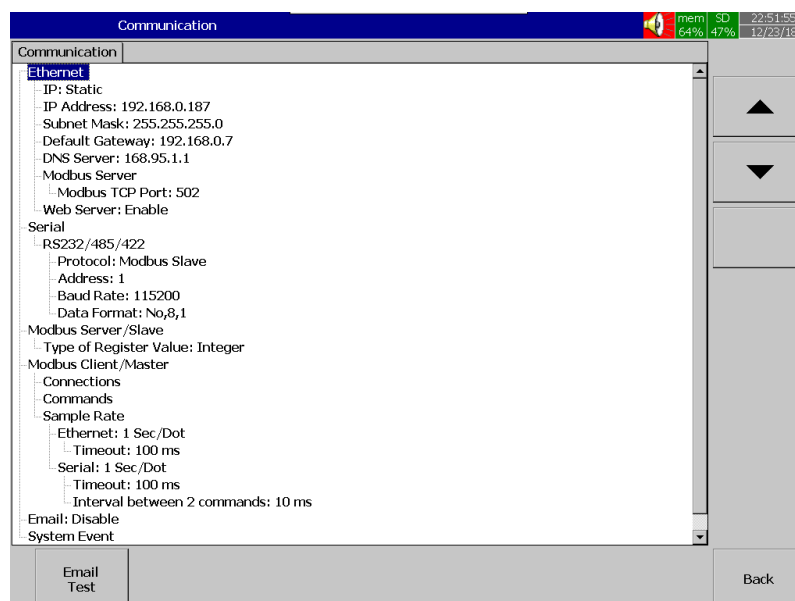

5.9.1 Ethernet

This will configure the Ethernet port configuration.

IP

Select the IP type as Static or DHCP as per the requirement. Select **DHCP** if the server on the network automatically allocates the IP address for the recorder. Select **STATIC** to manually set a fixed address for the recorder.

IP Address: Defines the IP address of the recorder on the network

Subnet Mask: Defines the Subnet Mask address on the network

Default Gateway: Defines the Gateway address.

DNS Server: This is required if the recorder needs to be connected to Internet

Modbus Server: When Recorder is configured as Slave Recorder (Server in Modbus TCP) in Modbus communication, the recorder needs to be configured with the port no.

Modbus TCP Port: Modbus TCP Port no. Default setting is 502 for Modbus TCP

Web Server: This will allow the user to enable or disable the web server feature on the recorder

5.9.2 Serial

This will configure the serial port of the recorder.

Protocol: Selects the Modbus protocol. The available options are Modbus RTU Master and Modbus RTU Slave.

Address: Recorder Slave Address in the network

Baud rate: Selects the communication baud rate for communication. The available options are 9600, 14400, 19200, 38400, 57600, 115200

Data format: Selects the communication data format for communication. The available options are none, 8, 1 or Odd, 8, 1 or Even, 8, 1

5.9.3 Modbus Server / Slave

This will allow the user to select the data type for the recorder communication when it act as a slave in Modbus RTU or server in Modbus TCP.

Type of Register Value: The user can select the data type as Integer or Floating point.

5.9.4 Modbus Client/Master

This will allow the user to configure the external channel communication with recorder.

5.9.4.1 Connections

Add the connections to the recorder. There are maximum of 16 devices can be connected with PPS-1000 and PPS-2000 and maximum of 32 devices can be connected with PPS-3000. To add a connection select **connections** and then press **Enter key**. It will show the connection menu parameters.

Name: Configure the connection name

Type: Select the connection type as Serial or Ethernet

Slave ID: Configure the Slave Id of the device to be connected.

IP: This is enabled only if Type = Ethernet. Configure the IP address of the slave.

Port: This is enabled only if Type = Ethernet. Configure the port no of the slave.

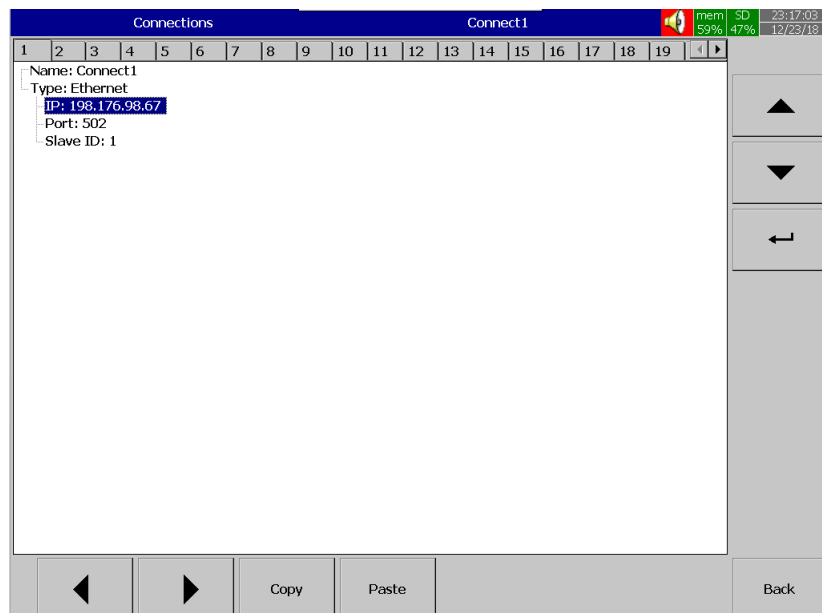
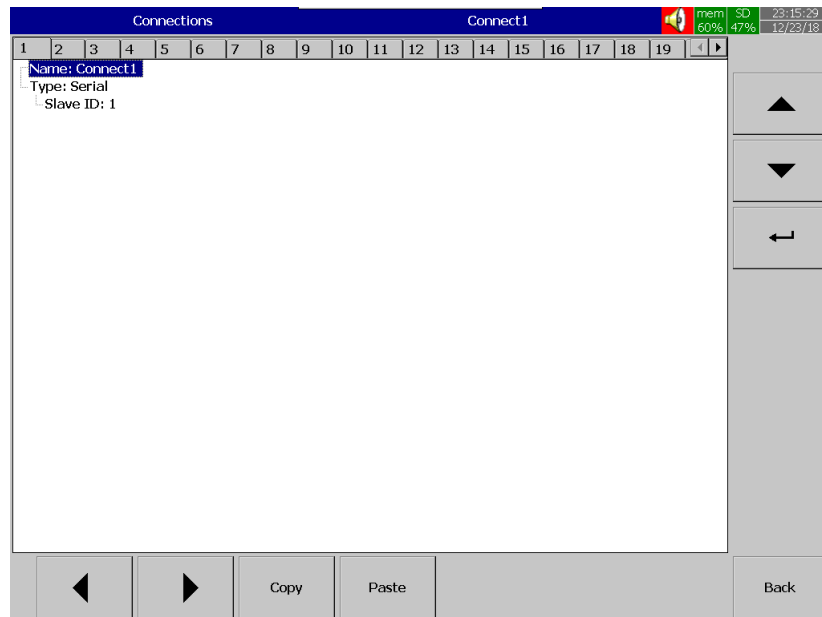

5.9.4.2 Commands

This will allow the user to configure the Modbus register address from the slaves needs to be map to external channel. There are maximum of 16 commands can be added in PPS-1000 and PPS-2000 and 32 commands can be added in PPS-3000. To add a command select **commands** and then press **Enter key**. It will show the commands menu parameters.

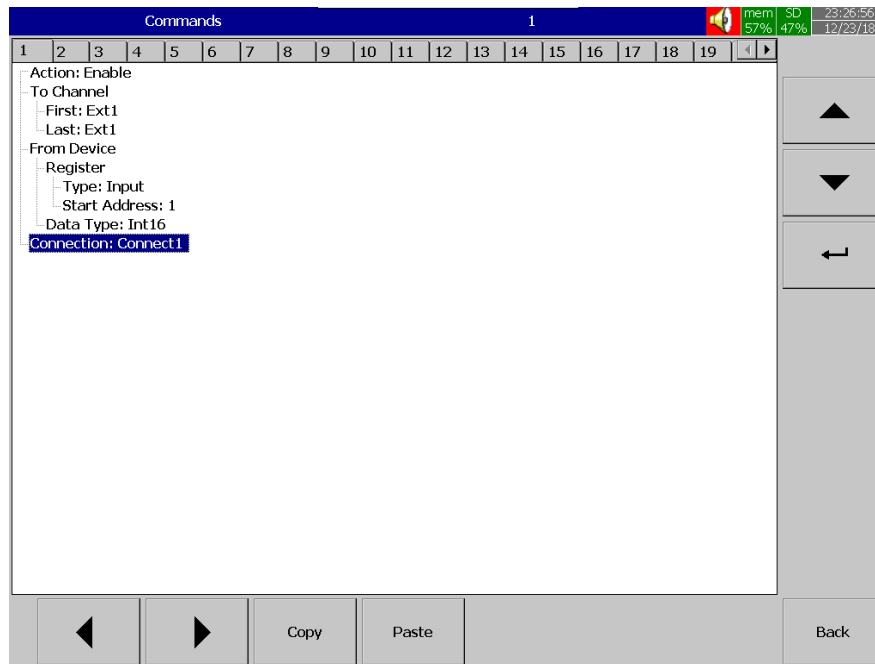

Action: Enable or Disable the command

To Channel: Configure the first and last channel of the external channel to be mapped.

First: Enter first external channel details, Ex: Ext1

Last: Enter last external channel details, Ex: Ext24

From Device: Configure the slave device to be mapped,

Register: Configure the Modbus address of the slave

Type: Select the Register type as per slave. The available options are Input and Holding Registers

Start Address: Enter Start register address. For example 400001 as 1

Data Type: Configure the data type as per slave configuration.
Int16/UInt16/Int32_B/Int32_L, UInt32_B, UInt32_L, Float_B, Float_L

Connection: Select the required connection where the slave is configured.

5.9.4.3 Sample Rate

Configure the sampling rate for communication.

Ethernet: Configure the Ethernet communication sampling rate from the available options
100 msec/dot, 1 sec/dot, 2 sec/Dot, 5 sec/dot, 10 sec/dot

Timeout: Timeout for Ethernet Communication. The default timeout is 100ms

Serial: Configure the Serial communication sampling rate from the available options
100 msec/dot, 1 sec/dot, 2 sec/Dot, 5 sec/dot, 10 sec/dot

Timeout: Timeout for Serial Communication. The default timeout is 100ms

Interval between two commands: Configure the interval between two commands in serial communication. The default time is 10 msec.

5.9.5 Email

This will allow the user to enable or disable the email function on the recorder. Once the email function is enable then the recorder will show the required menus to configure the email server details. The user has to configure the email server configuration as per the email server. The below picture shows the sample configuration with email account from Gmail to send email.

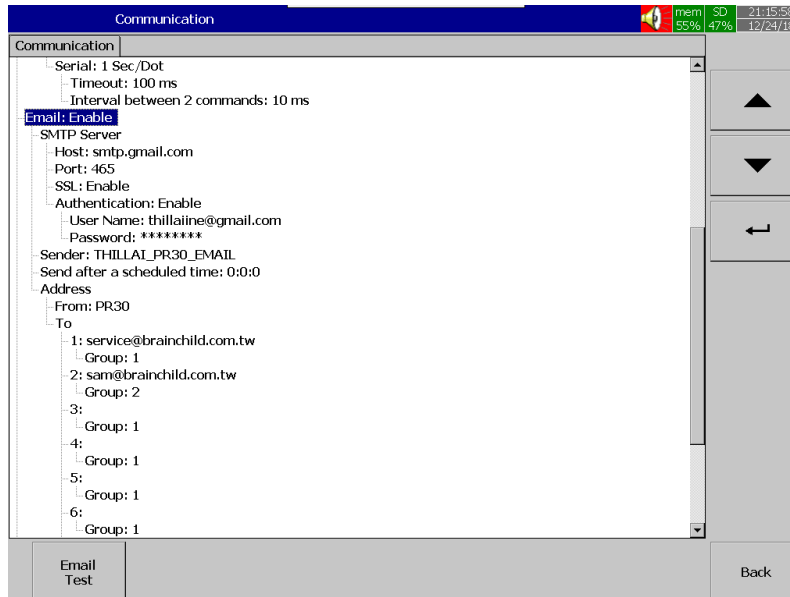

The user can configure the starting time of a day to start sending email. This time can be configured in **Send after a scheduled time**. This will avoid unnecessary email alarms when the process is not running or during maintenance. There are 10 different email address can be configured to send the emails. Every email action can select a particular sender or all the senders in the email job configuration.

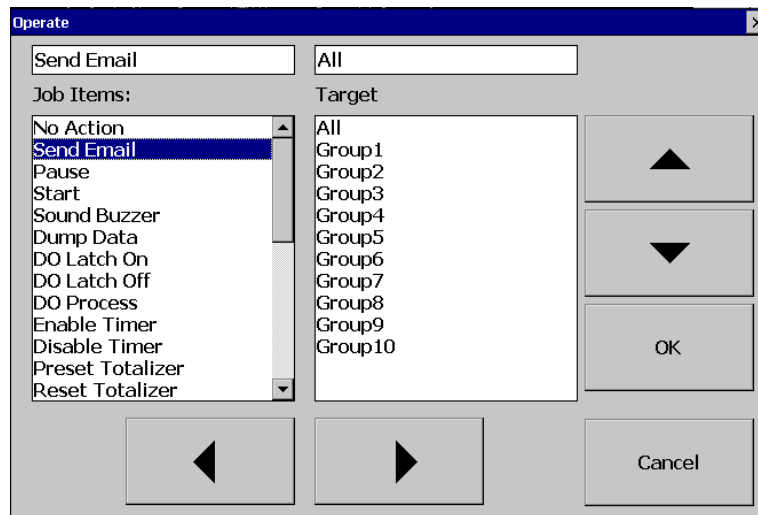

The system events can be enabled or disabled to send email notification by enabling or disabling the option **System event send email** function. Press **Email Test**  key to test the email configuration. If the configuration and the connection is successful then the recorder will send email to all the sender in the configuration. If there is a problem in email delivery then it will give an error message as below.

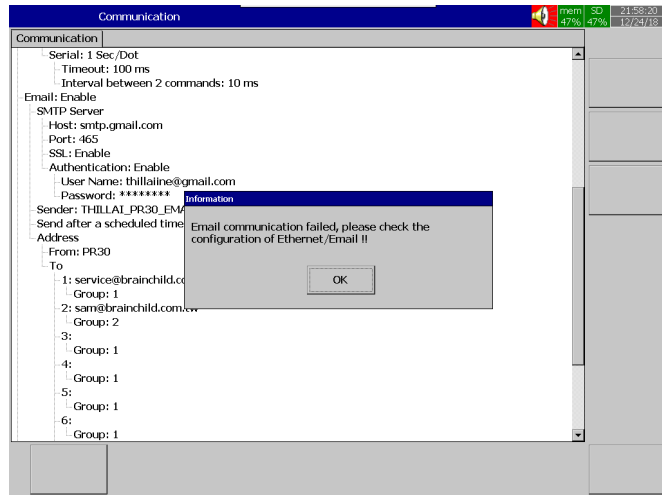

The email server should accept less secure app access. The below show the configuration of Gmail account accepts the less secure app access.

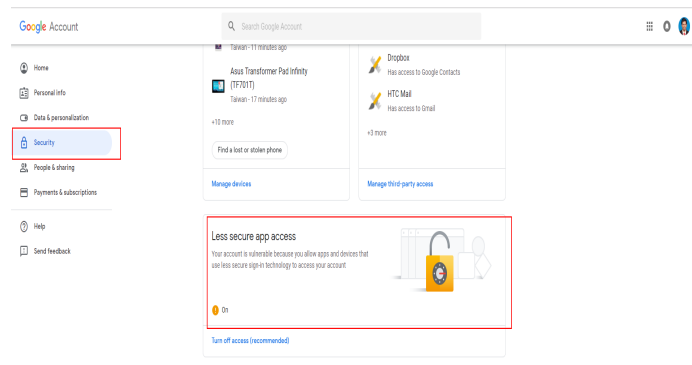

5.9.6 Example for IO Modules as External Channels

Paperless recorder connected with IO modules with slave address 2 and 3 via RS485 communication. The communication parameters for the communication are as below.

- ❖ Baud Rate: 9600
- ❖ Parity: None
- ❖ Data Length: 8 Bit
- ❖ Stop Bit: 1

The below picture shows the system configuration.

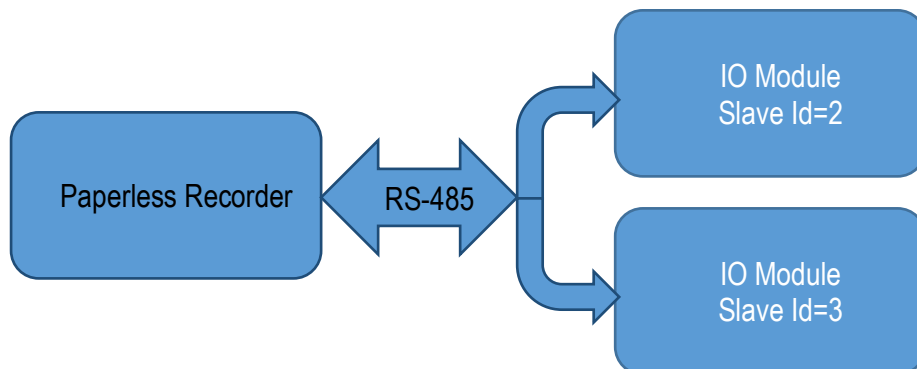

The below table shows the Modbus address mapping of IO Modules which needs to be mapped to external channels of recorder.

Modbus Address	Register Name	Low Limit	High Limit	Access
30002	Analog Input 1	0	4095	R
30003	Analog Input 2	0	4095	R
30004	Analog Input 3	0	4095	R
30005	Analog Input 4	0	4095	R
30006	Analog Input 5	0	4095	R
30007	Analog Input 6	0	4095	R
30008	Analog Input 7	0	4095	R
30009	Analog Input 8	0	4095	R

The recorder communication protocol must be set as Modbus Master to communicate with external channels.

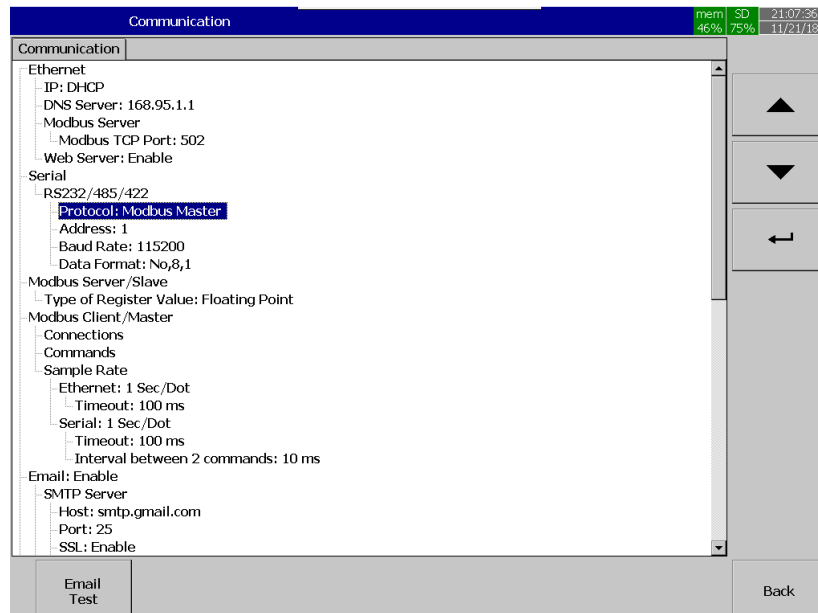

Configure the communication parameters as per the slave (IO Module) configuration.

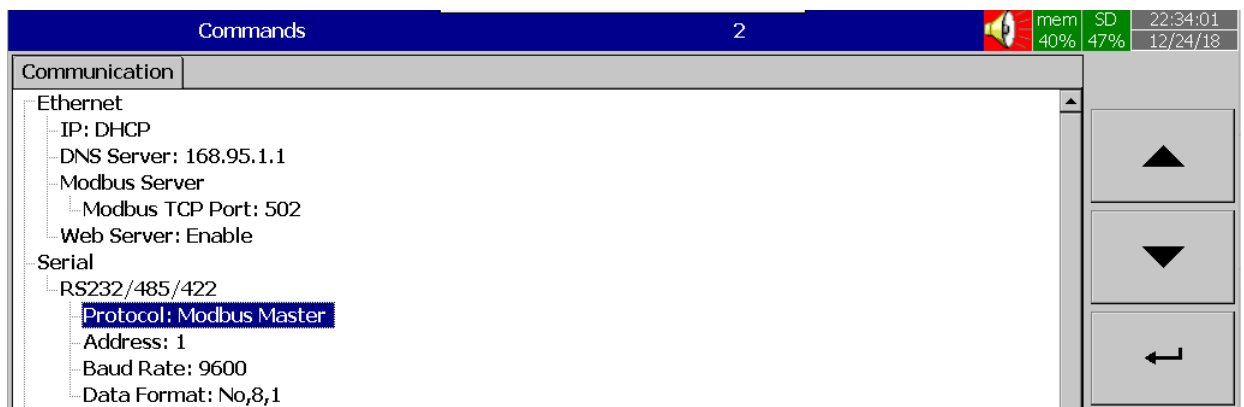

Add connections and commands as per IO module configuration.

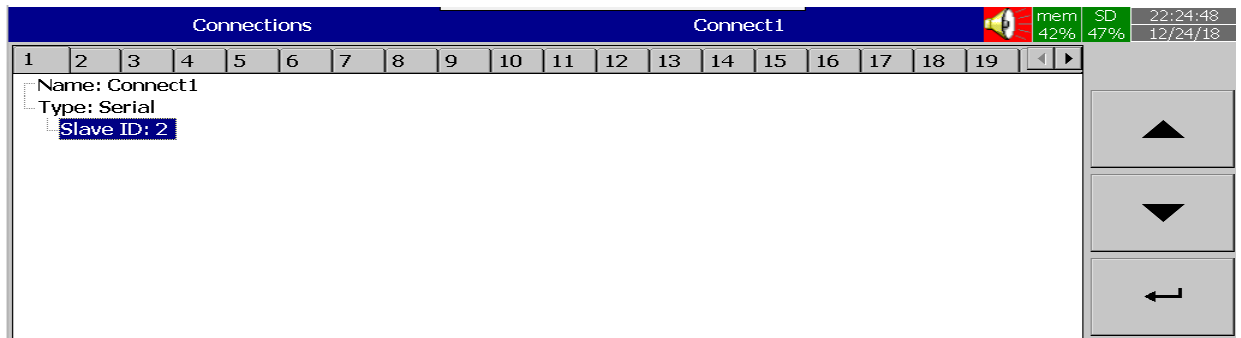

5-19 Connection for Slave ID 2

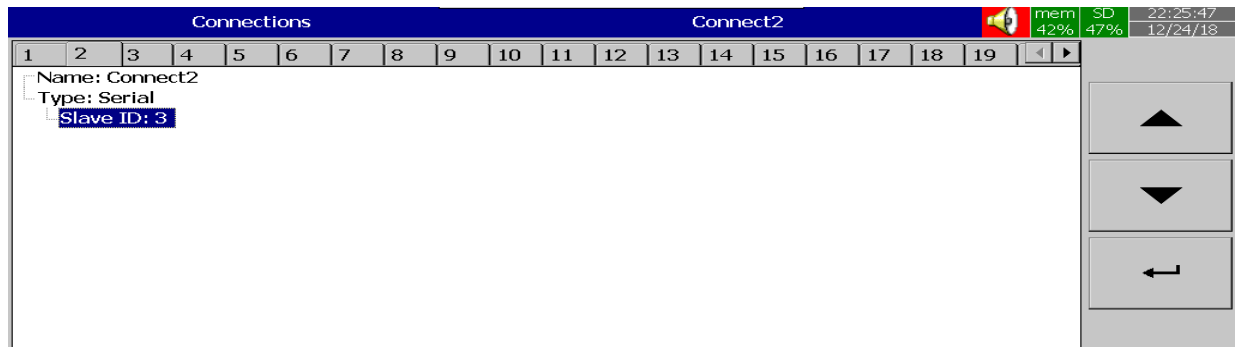

5-20 Connection for Slave ID 3

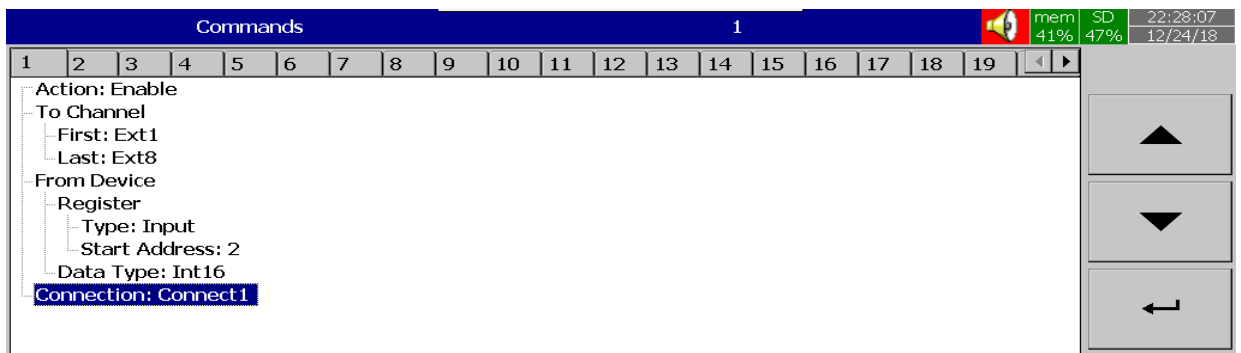

5-21 Mapping of IO Module and External Channel for Slave ID2

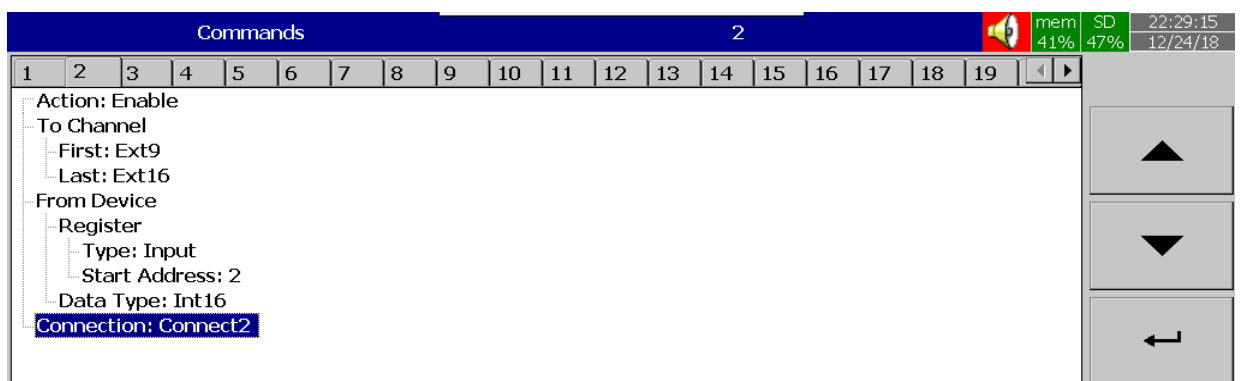

5-22 Mapping of IO Module and External Channel for Slave ID 3

After the mapping of IO module with external channel is successful then all mapped external channel needs to be configured for displaying the data with proper scaling.

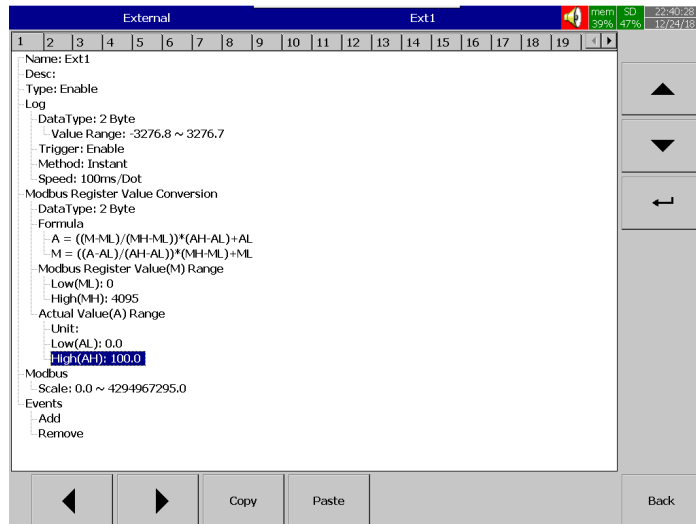

Configure display page to display External channel in display pages

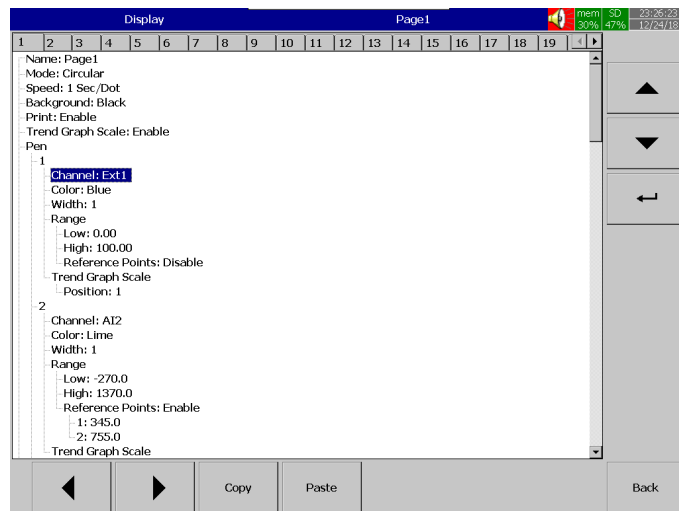

5.9.7 Example for Controller as External Channels

Paperless recorder connected with temperature controller with slave address 2 via RS485 communication. The communication parameters for the communication are as below.

- ❖ Baud Rate: 9600
- ❖ Parity: None
- ❖ Data Length: 8 Bit
- ❖ Stop Bit: 1

The below picture shows the system configuration.

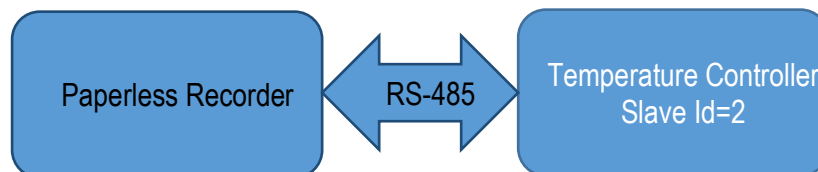

The below table shows the parameters needs to be mapped and logged from temperature controller to external channels of recorder.

Register Address	Parameter Notation	Parameter Description	Range	Default Value	Data type
128	PV	Process value	Low: -32768 High: 32767	—	R
129	SV	Set point value for control	Low: SPLO High: SPHI	—	R

The recorder communication protocol must be set as Modbus Master to communicate with external channels.

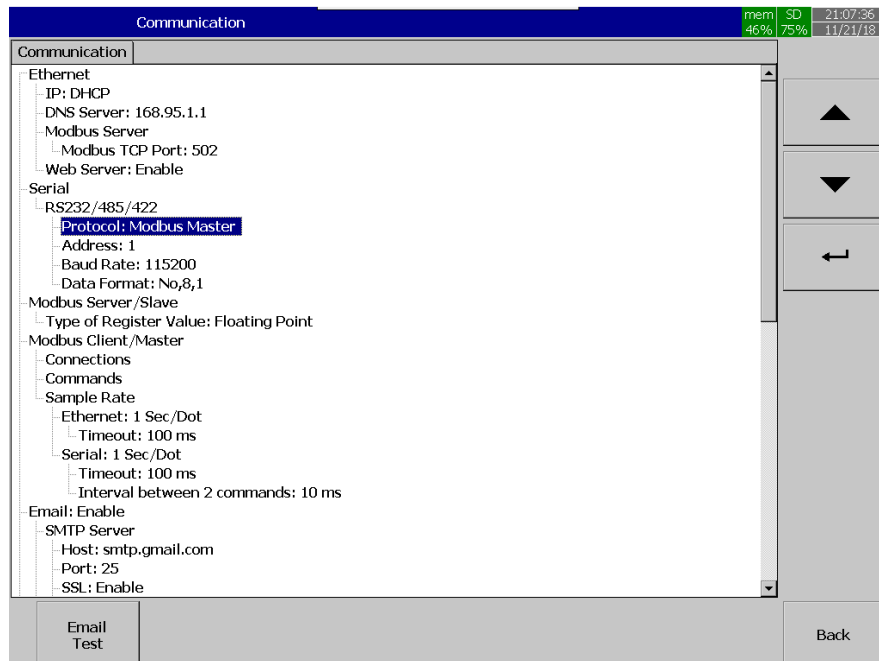

Configure the communication parameters as per the slave (controller) configuration.

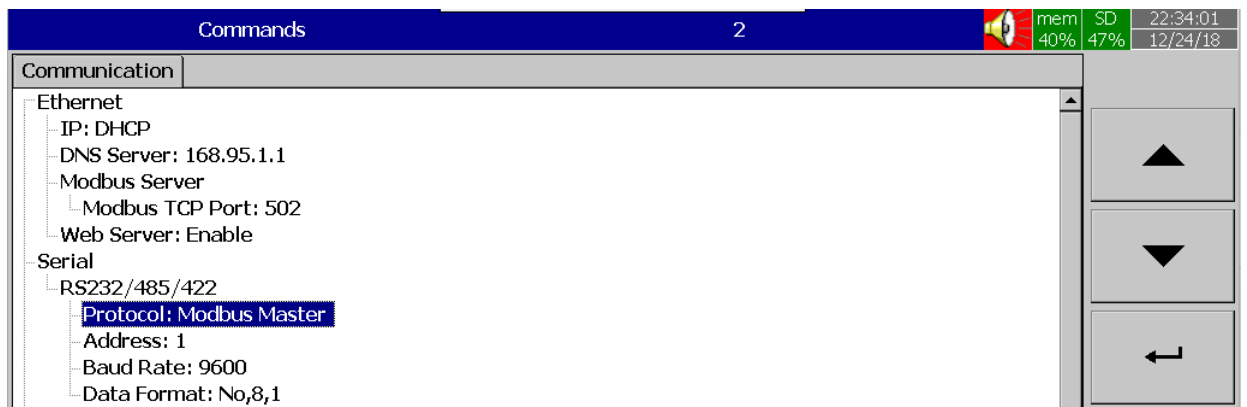

Add connections and commands as per controller configuration.

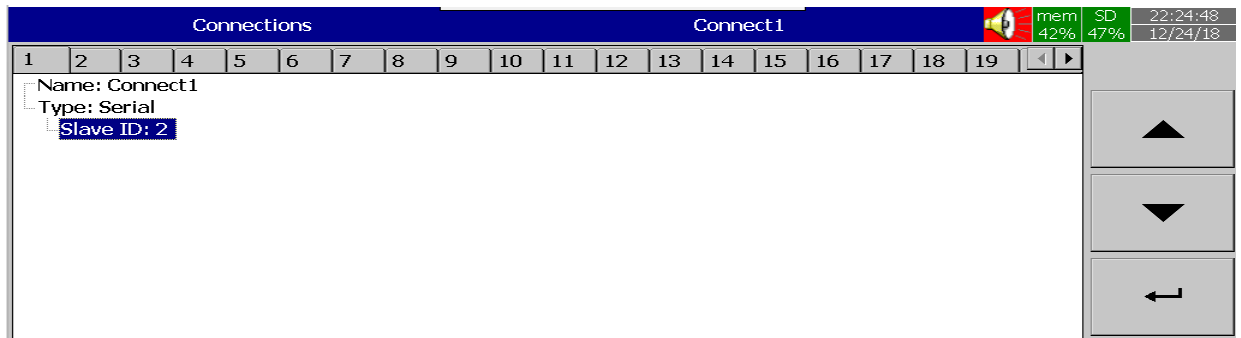

5-23 Connection for Slave ID 2

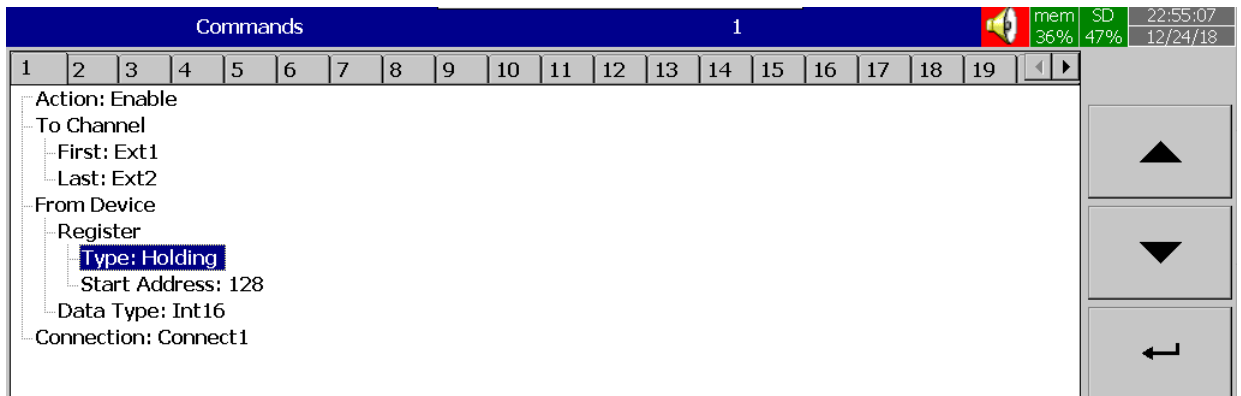

5-24 Mapping of Controller with External Channels

After the mapping of controller with external channel is successful then all mapped external channel needs to be configured for displaying the data with proper scaling.

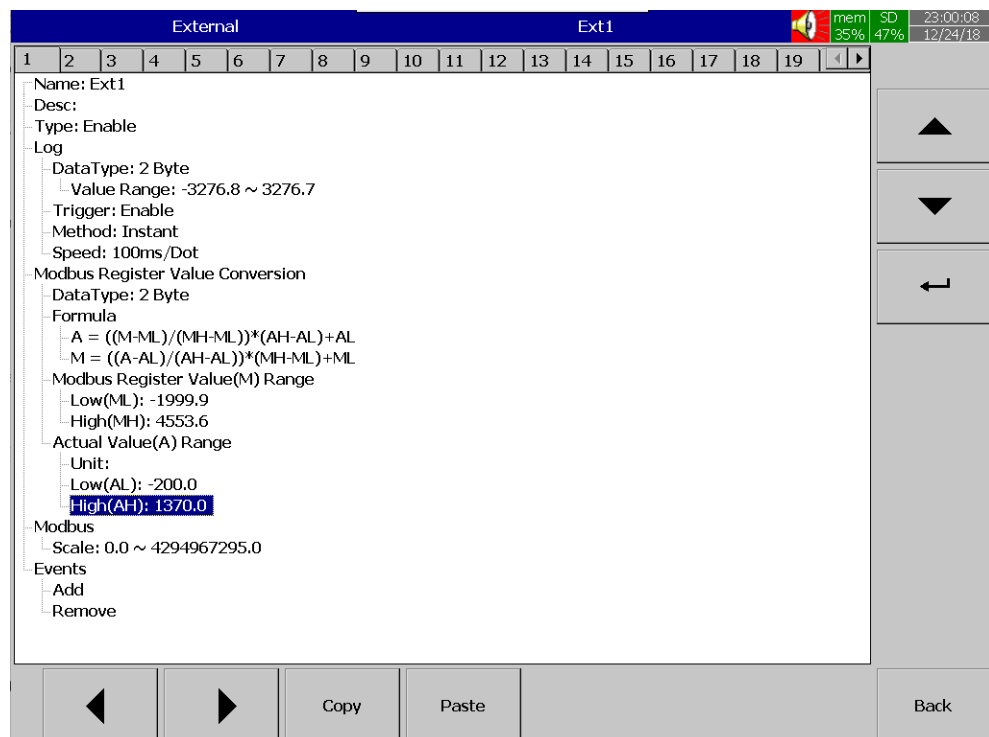

Configure display page to display External channel in display pages

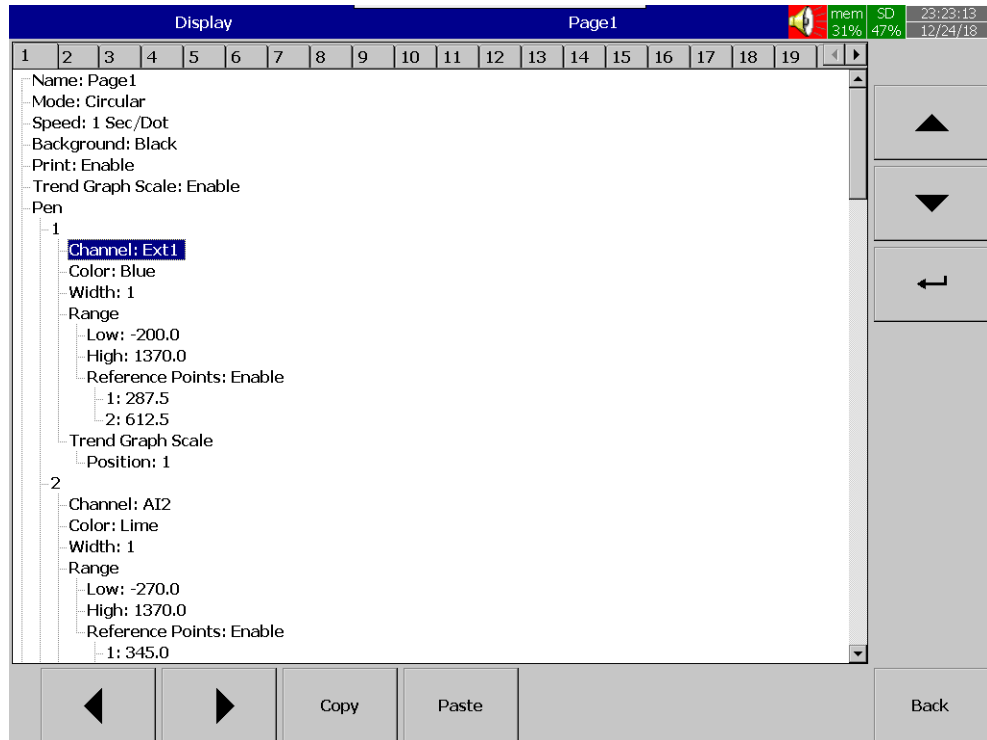

5.9.8 Example for SIO Module as External Channel via PC-E

Paperless recorder connected with SIO module with slave address 1 using RS485 to Ethernet Converter PC-E connected with Ethernet communication.

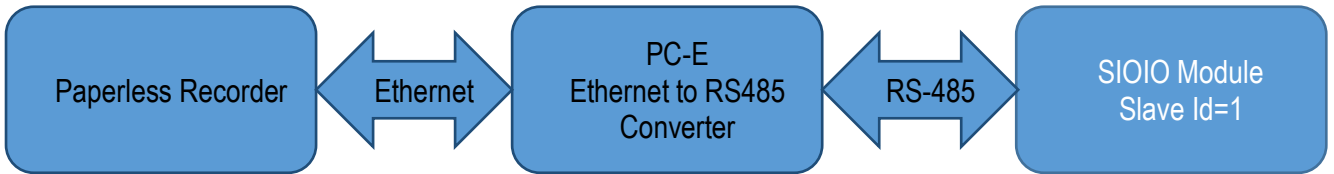

The communication parameters for the communication are as below.

SIO Module Configuration

Address: 1
 Baud Rate: 9600
 Parity: None
 Data Length: 8
 Stop Bit: 1

The below table shows the Modbus mapping of SIO series IO module.

Address	Function	R/W	Initial Value
30513~30520			
40513~40520 (0x0200~0x0207)	AI CH0 ~ CH7 Value	R	-

PC-E Configuration

Ethernet Configuration Parameters				
Module IP	192 112	168	0	
Default Gateway IP	192 1	168	0	
Subnet Mask	0 0	0	0	
Socket Time Out	90			X 1 second

5-25 PC-E Ethernet Configuration

Communication Modes			
Converter Mode	0	0 = Server - Standard Mode / Multi Socket 1 = Server - Socket Listen Mode / Single socket 2 = Client - Remote Socket Open Mode / Single socket	
Char Timeout	25	Time to wait before sending Rx Chars when using Port 30004 in Mode 0, or using Mode 1/2 X 10 milliseconds	
Port Number	502	Modbus TCP = 502 Mode 1&2 only	
Server IP	192 113	168 0	Mode 2 only
Modbus Comms Watchdog	0	X 1 minute	

5-26 PC-E Mode Configuration

RS232/RS485 Communications Port Parameters		
Baud Rate	9600	
Data Bits	8	
Parity	0	0=None, 1=Even, 2=Odd
Stop Bits	1	
RS232/RS485	1	0=RS232, 1=RS485
Serial Reply Timeout	30	X 10 milliseconds
RS485 On Delay	0	X 1 milliseconds
RS485 Off Delay	0	X 1 milliseconds

5-27 PC-E PS485 Configuration

The recorder communication protocol must be set as Modbus Master to communicate with external channels

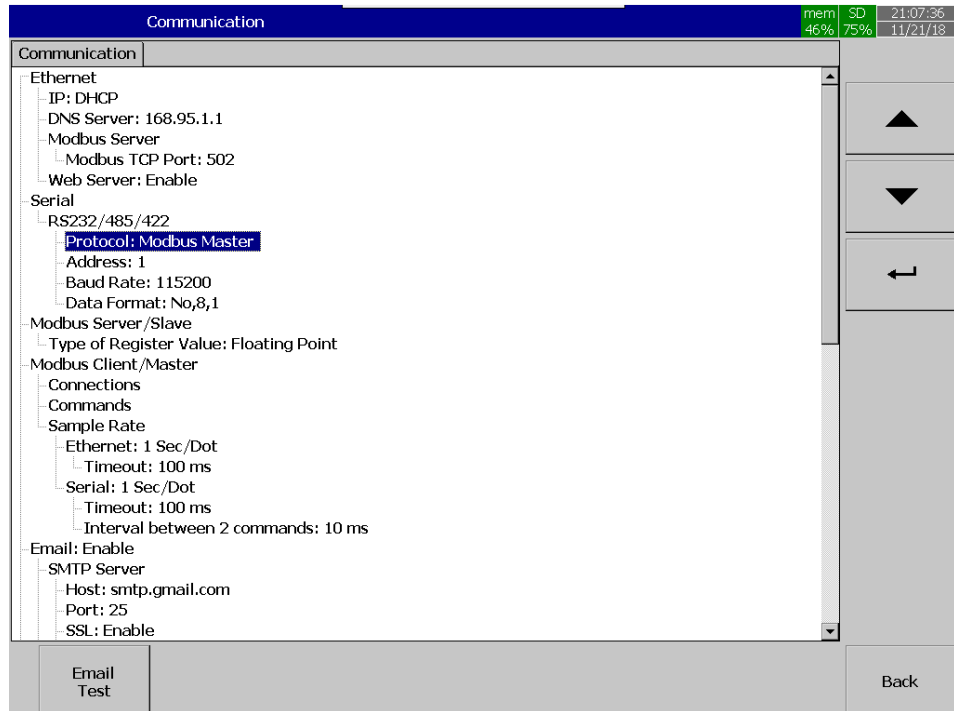

Configure the communication parameters as per the slave (PC-E and SIO) configuration. Add connections and commands as per PC-E and SIO module configuration.

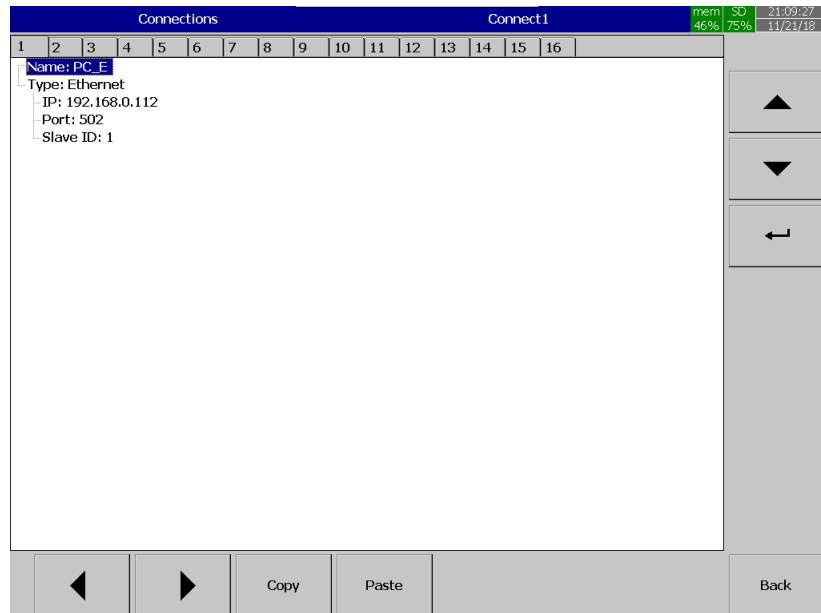

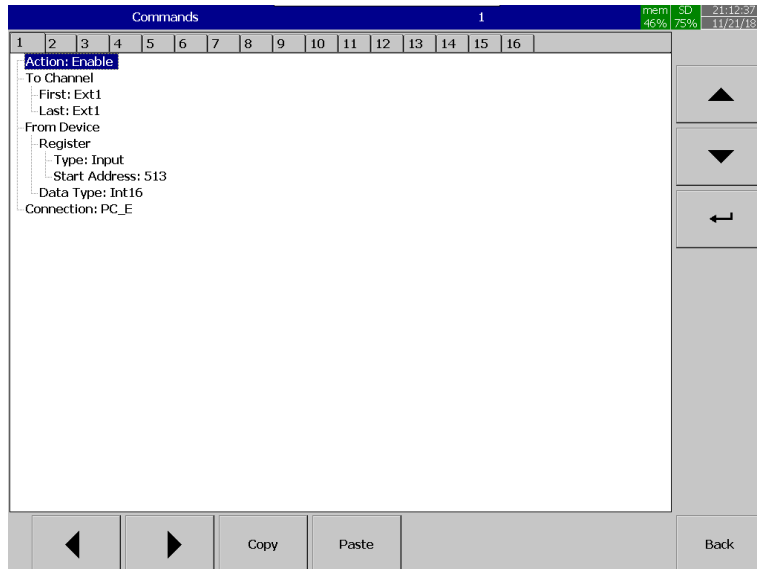

Configure the sample rate for the communication.

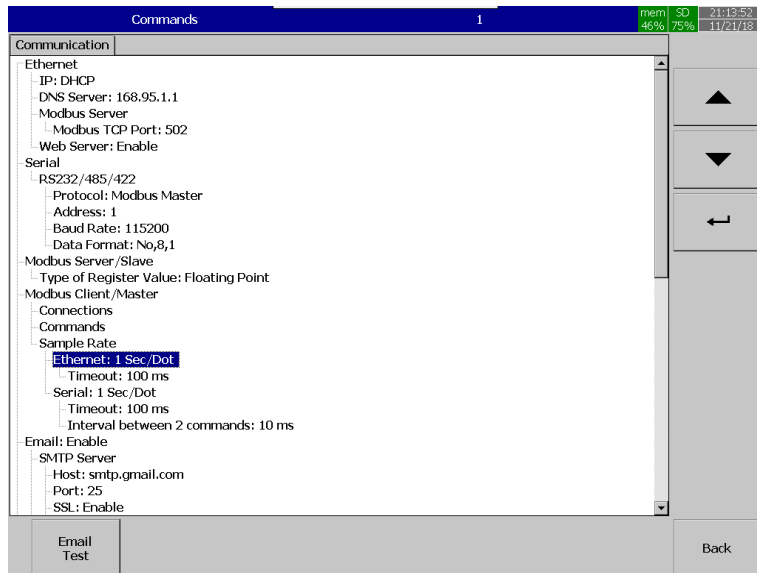

Configure External channel parameters and scaling.

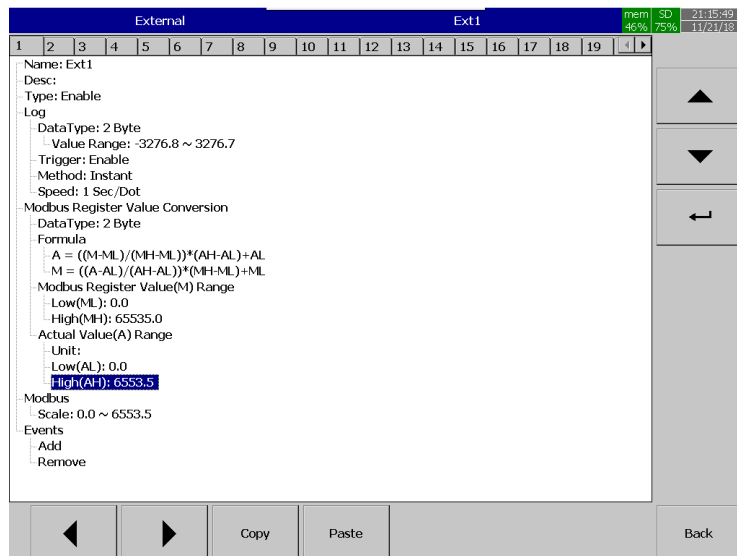

Configure display page to display External channel in display pages

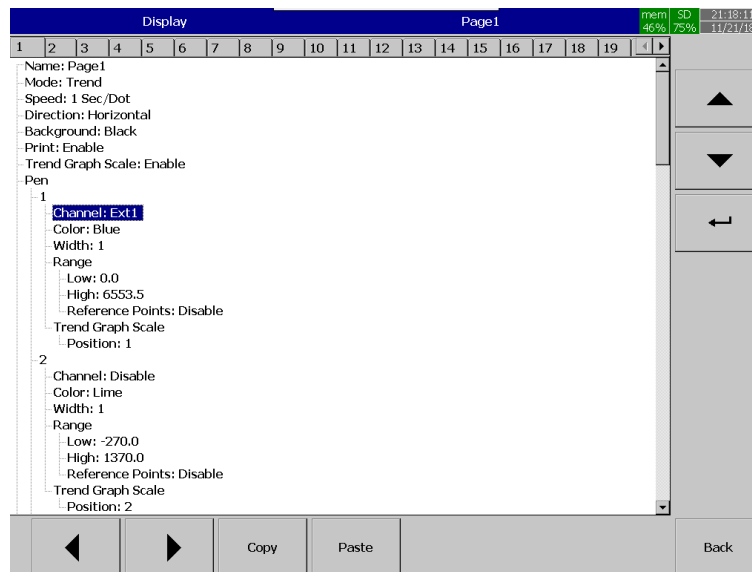

5-28 Display Page for Ext1

5.9.9 Example for Recorder as Modbus Slave

In this example the recorder will act as Modbus slave with id 2 and 3 which will communicate with Modbus Master on the PC via RS485 communication.

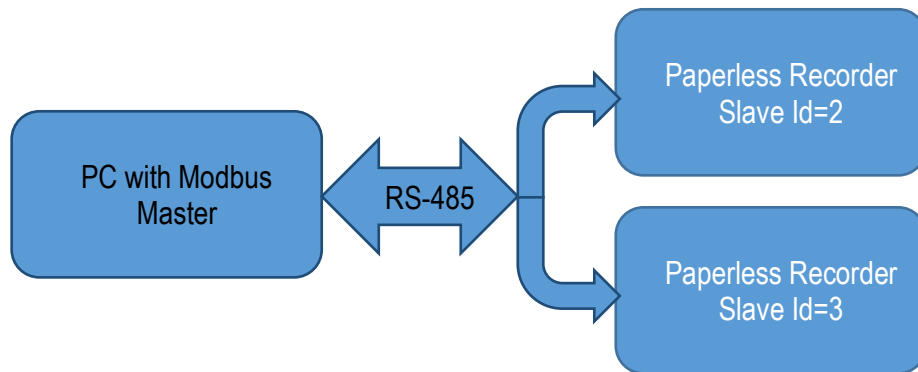

1.1 AI / DI / DO / AO Area (Integer Type)

Modbus Address	Notation	Register Name	Access
1	Reserve	Reserve	R
2	AI1	AI 1 process value	R
3	AI2	AI 2 process value	R
4	AI3	AI 3 process value	R
5	AI4	AI 4 process value	R
6	AI5	AI 5 process value	R
7	AI6	AI 6 process value	R





5-29 PR as Modbus Slave with ID 2



5-30 PR as Modbus Slave with ID 3

5.10 Instrument

This will allow the user to configure the Instrument related parameters like Batch, Security mode. After entering the Configuration menu, select **Instrument** then Press the **Enter** key to get into Instrument configuration menu. It displays the Instrument related configuration menu to configure. Press directional

keys   on the right hand side to select the menu column. After completing Configuration,

press  soft key, then press  soft key to return to main display. All configurations will be saved automatically.

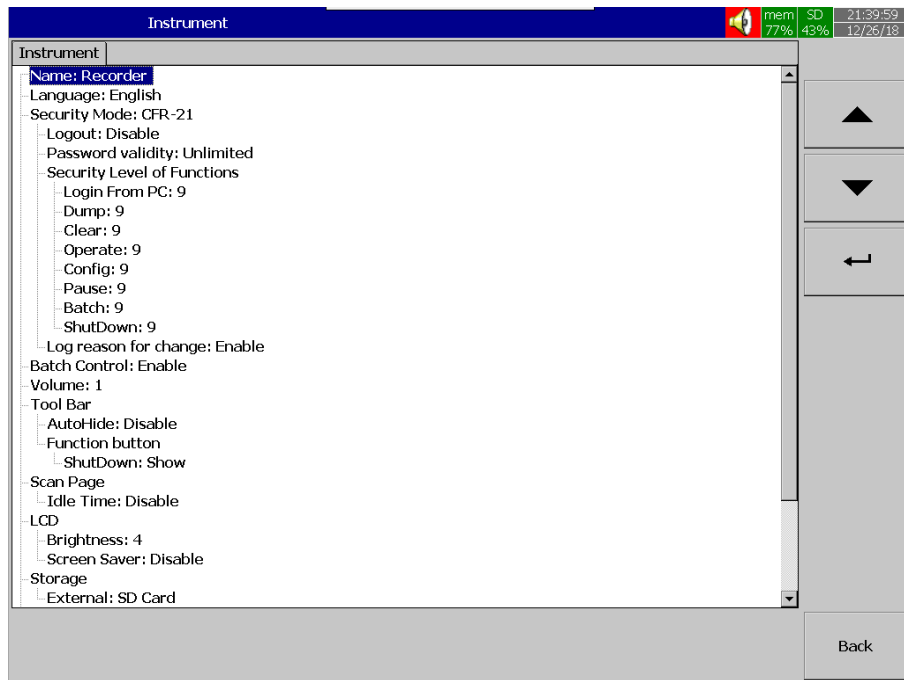

5.10.1 Name

This enables the User to define the name for the recorder with a maximum of 18 characters. Select “Name”, then Press “Enter”, soft key, a keyboard with several keys will appear. Press “Shift” to select special characters. Press “Caps” to select capital letters. Press soft key “OK” after entering a new recorder name.

5.10.2 Language

There are 20 different languages available for the user to select for user interface. They are English, Simplified Chinese, Traditional Chinese, Japanese, Korean, French, German, Italian, Polish, Spanish, Portuguese, Brazil Portuguese, Russian, Thai, Czech, Danish, Dutch, Swedish, and Turkish & Greek.

5.10.3 Security

This will allow the user to select the security mode as Normal or CFR-21. Once the CFR-21 mode is enabled the related menus will be showed for the user to configure.

5.10.3.1 Logout

The automatic log out time for the device to logout when there is no user interface on the device. This option is available only for CFR-21.

5.10.3.2 Password validity

The user can configure the validity of the password for a period. The available options are 30 days, 60 days, 90 days and unlimited.

5.10.3.3 Security Level of Functions

There are different level of security can be configured for different function. The security level can be configured from 1 to 9. In this 9 is the highest level and 1 is the lowest level. The different functions can be configured with different security levels are listed as below.

1. Login from PC
2. Dump
3. Clear

4. Operate
5. Config
6. Pause
7. Batch
8. Shutdown

5.10.4 Batch Control

The batch function can be enabled or disabled.

Note: It is necessary to restart the recorder after changing the batch control.

5.10.5 Volume

The buzzer volume of the recorder can be disable or can be set from 1 to 10. The buzzer can be disabled by configuring Volume as Disable.

5.10.6 Tool Bar

The drop down menu of menu  key can be hidden automatically after a period of inactivity. The inactivity time can be configured by configuring 10 Sec or 20 Sec or 30 Sec in **Auto Hide**. If Auto Hide is configured with disable then the drop down menu will not hidden.

5.10.7 Scan Page

The configured displayed pages can be scrolled automatically after a period of idle time configured in **Idle Time** with a constant interval configured in **Scan Rate**. The idle time can be configured from 1 Min to 10 Min and Scan rate can be configured from 5 sec to 30 sec. The scrolling of pages can be disabled by configuring Idle Time as Disable.

5.10.8 LCD

The LCD Brightness can be configured from level 0 to 6. The level 0 is the lowest brightness and level 6 is for the highest possible brightness.

The life time of LCD can be increased by configuring screen saver to turn off the display after a period of inactivity on the screen. During the screen saver mode the data will be recorded continuously without any loss. The LCD screen only be off at that time. The screen saver time can be configured from 1 Min to 60 Min. The screen saver can be disabled by configuring Disable in Screen saver.

5.10.9 Storage

The external storage type can be chosen from the available options SD Card or USB Disk. The default setting for external storage set as SD card. The maximum size of external memory supported is 32GB. The external storage must be formatted in FAT or FAT32 format.

5.10.10 Data Transfer

The data transfer option can be set as Dump and Clear or Transfer and Remain. Dump and Clear will clear the data from internal memory after dumping. Transfer and remain will keep the data in internal memory after dumping.

5.10.10.1 Show Message at the End

This will enabling or disabling the conformation message after dumping is finished.

5.10.11 Custom Page

The user can enable or disable the custom page download via Ethernet from Panel Studio Software by choosing Enable or Disable in Allow Download via Ethernet.

5.10.11.1 Power on

The user can set a custom page to display after power on. This set page will show after the recorder after power on.



5.10.12 Setup Start-up Image

The user can add a start-up image like a logo to shown during power on.

5.10.12.1 Procedure to Setup a Start-up Image

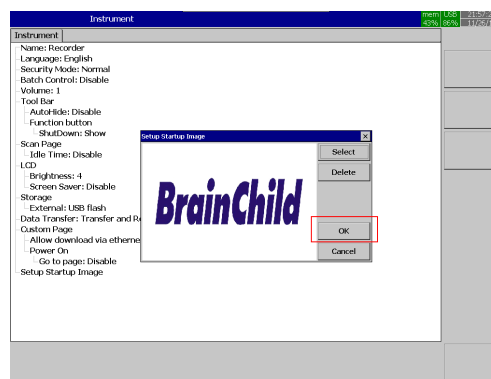
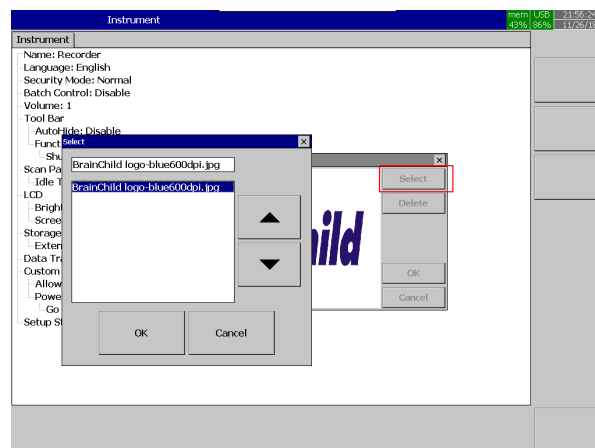
1. Copy the image to main path of SD Card or USB Disk
2. Insert the external storage to PR
3. Set the external storage to SD card or USB as per the connected storage
4. Select the image by using the setup start-up page option in Instrument menu.



5. After completing Configuration, press  soft key, then press  soft key to return to main display. All configurations will be saved automatically.
6. Now the recorder will start with the selected image.

5.11 Security

5.11.1 Normal

If normal mode is selected in security mode in instrument menu then the user can define a common password with a maximum of 18 characters. Once the password has been configured then the user needs to key in the password to access **Config, Dump, Clear, Operate** soft keys. These keys enable

the user to do configuration, dump data, clear data or manually operate the job. For easy access the user may leave the password field empty.





After entering the Configuration menu, select **Password** then press the **Enter** key to get into password configuration menu.

5.11.2 CFR-21

If CFR-21 is selected in security mode in instrument menu then the data recorded in the instrument will comply with FDA 21 CFR Part11. The recorder also provides audit trail report through event list. There are 30 different user accounts can be configured with different level of authority. There are 9 different levels of security can be configured. In this level 9 considered as a higher level authority and level 1 consider as lower authority level.

5.11.2.1 User Account

This will allow user to configure the user account like user name, security level. After entering the Configuration menu, select **User Account** then Press the **Enter** key to get into user account configuration menu. It displays user account user1 as the first user to configure. Press directional navigation

keys  at the bottom to select other users. Press directional keys  on the right hand side to select the menu column. After completing Configuration, press  soft key, then press  soft key to return to main display. All configurations will be saved automatically.

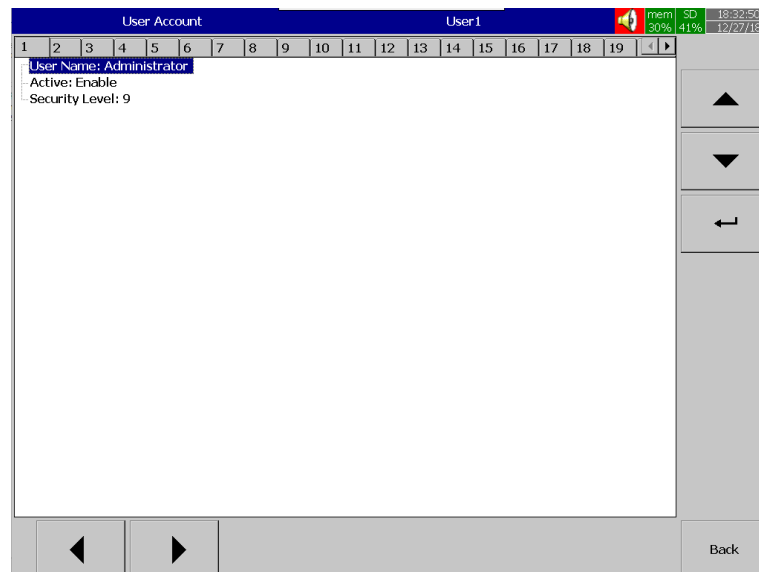

5.11.2.1.1 User Name

This enables the User to define the user name for the user account with a maximum of 18 characters. Select "User Name", then Press "**Enter**", soft key, a keyboard with several keys will appear. Press "**Shift**" to select special characters. Press "**Caps**" to select capital letters. Press soft key "**OK**" after entering a new recorder name.

5.11.2.1.2 Active

The user account can be enabled or disabled by choosing Enable or Disable in Active.

5.11.2.1.3 Security Level





The security level of the user account can be defined from 1 to 9 where 9 is the highest level and 1 is the lowest level.

Note: It is necessary to restart the recorder after changing the security mode.

5.12 Demo

The Demo mode is a simulation mode used as a sales tool for demonstration purposes. It is set to simulate AI analog inputs and Math functions. After entering the Configuration menu, select **Demo** then press the **Enter** key to select Enable or Disable the Demo. After completing Configuration, press  soft key to return to main display. All configurations will be saved automatically. It is necessary to save and restart the recorder after changing the demo menu option.

5.13 Auto-Output

This will allow the user to configure the auto output configuration for automatic output in output historical data and print related jobs. After entering the Configuration menu, select **Auto-Output** then press the **Enter** key to get into Auto output configuration menu. Press directional keys   on the right hand side to select the menu column. After completing Configuration, press  soft key, then press  soft key to return to main display. All configurations will be saved automatically.

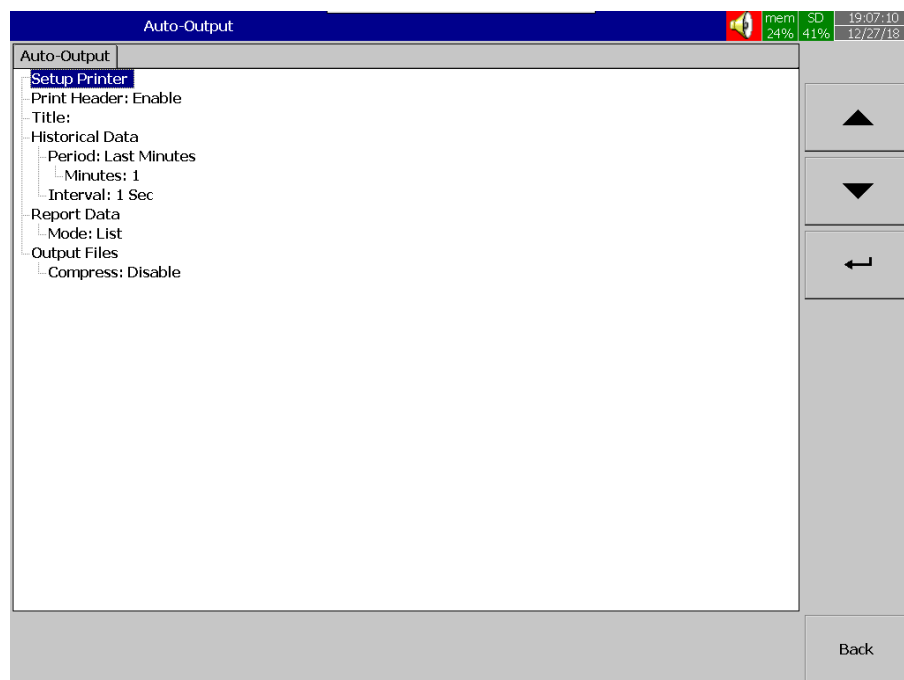

5.13.1 Setup Printer

This will allow the user to configure the printer. Select Setup Printer and press Enter soft key to access printer configuration menu.

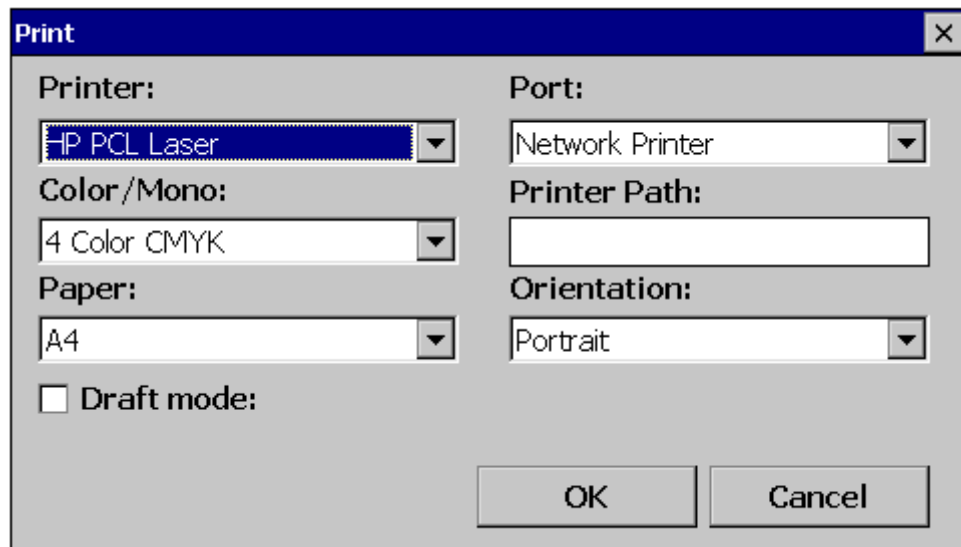

Printer: Select the printer type. There are five types of printer drivers supported. They are listed as below.

1. HP PCL Laser
2. Epson ESC/P
3. Adobe PDF file
4. HP PCL Inkjet
5. Epson ESC/POS

Port: Select the printer port as per the connection. Select Network Printer for the printers connected in Ethernet port and select LPT1 for the printers connected in USB Port.

Color/Mono: Select the color as per the printer configuration. The available options are Monochrome, 4 color CMYK, 3 Color CMY.

Printer Path: Configure the network printer path as per the connection. The syntax for the network printer path as given below.

❖ For Network Printer

\\IP address of printer: Port no

Example: 192.168.0.197:9100

❖ For Shared printer

\\PC Name\Printer Share name

Example: \\THILLAI-PC\HP

Paper: Select the paper size.

Orientation: Select the orientation as Portrait or Landscape.

Draft Mode: Select Draft mode for printing as draft mode.

5.13.2 Print Header

The user can Enable or Disable the headers in the printing. Generally the recorder will print with related information of the data in header in all the pages. This header can be disabled by selecting Disable in Print header.

5.13.3 Title

The title available on the print header can be configured in this option.

5.13.4 Historical Data

The period and interval of historical data to be printed can be configured by selecting the period and interval. Print Historical Data and Print Event List will follow the period configured in this menu.

Period: Select Last hours or Last days

Hours/Days: Select no. of hours or no. of days to be printed.

Interval: Select interval of data to be printed from 100 msec / 1 Sec / 2 Sec / 5 Sec / 10 Sec / 15 Sec / 20 Sec / 30 Sec / 1 Min / 5 Min / 10 Min / 15 Min / 20 Min / 30 Min / 45 Min / 1 Hour / 2 Hour

5.13.5 Report Data

The mode of report to be printed can be selected in this option. This print Report List will follow the mode configured in this menu. In the **Mode**, select which kind of Reports are required. Available options are List, Daily, Weekly and Monthly.

5.13.6 Output Files

The output files can be compressed by choosing enable in compress menu.

5.13.7 USB Printer Configuration

The USB printers can be connected directly via front or rear USB port of the recorder. The printer should support PCL4 or PCL5 or PCL6 or ESCP.

Note: Do not use USB printer supporting only PCL to print single line alarms, otherwise, pages will be Wasted.

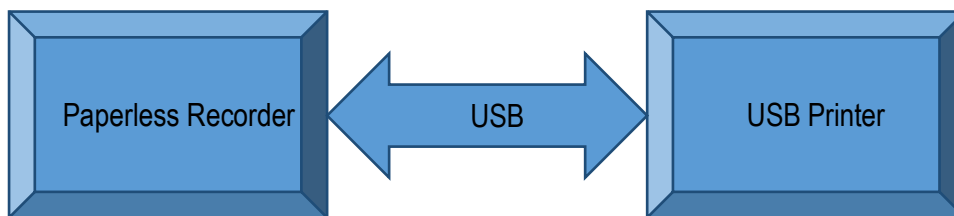

5.13.8 Network Printer Configuration

The network printers or shared printers can be connected via Ethernet port of the recorder. The printer should support PCL4 or PCL5 or PCL6 or ESCP.

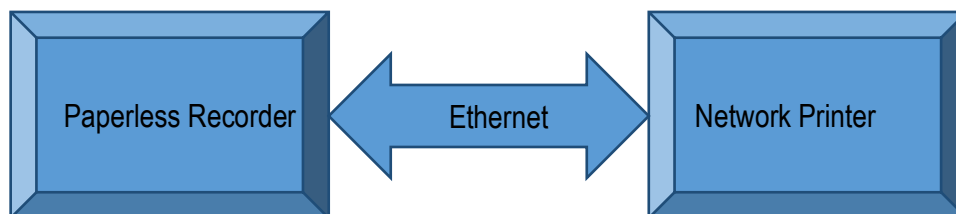

5-31 Network Printer Connection

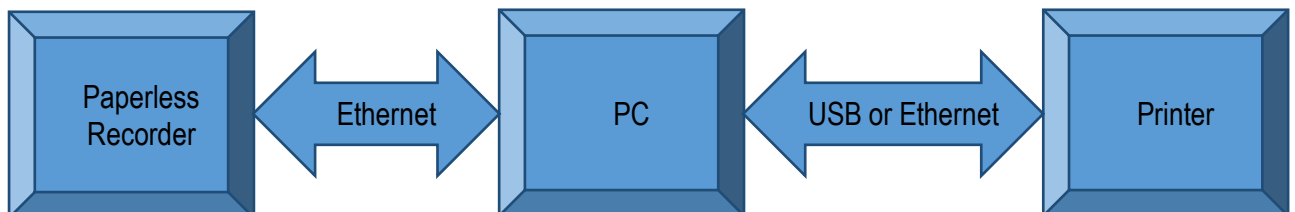

5-32 Shared Printer Connection

5.13.9 Sample Configuration of Printer

Steps to be followed for printer configuration as below.

1. Select the Printer Driver

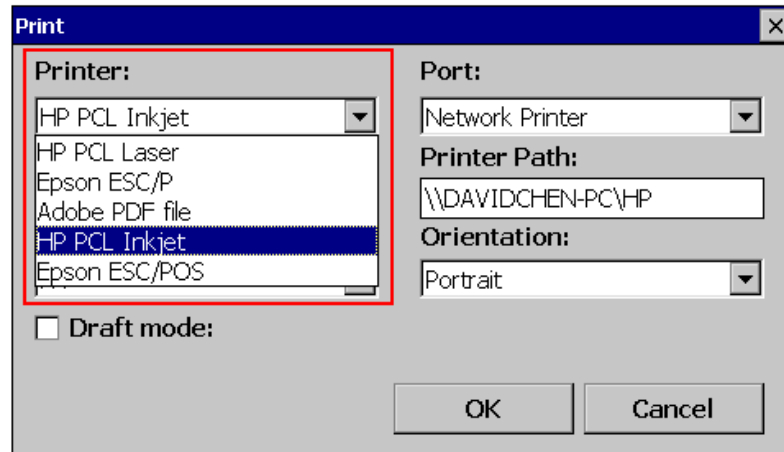

2. Select the Port.LPT1 for USB Printer and Network printer for Network Printer and Shared printer.

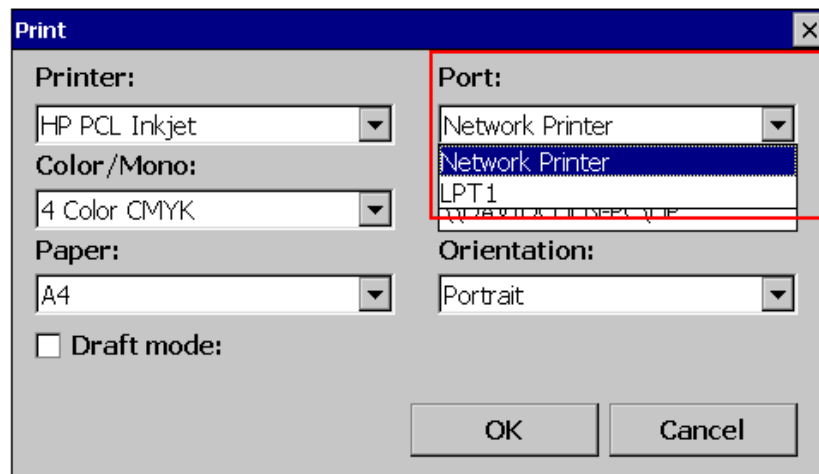

3. Set the Printer Path as per the connection.
 - ❖ For USB Printer the path is not applicable.

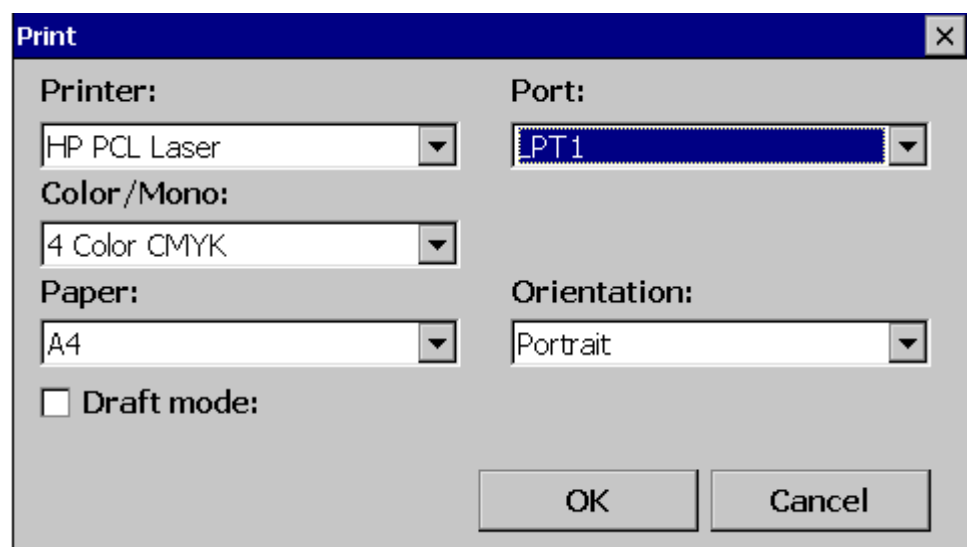

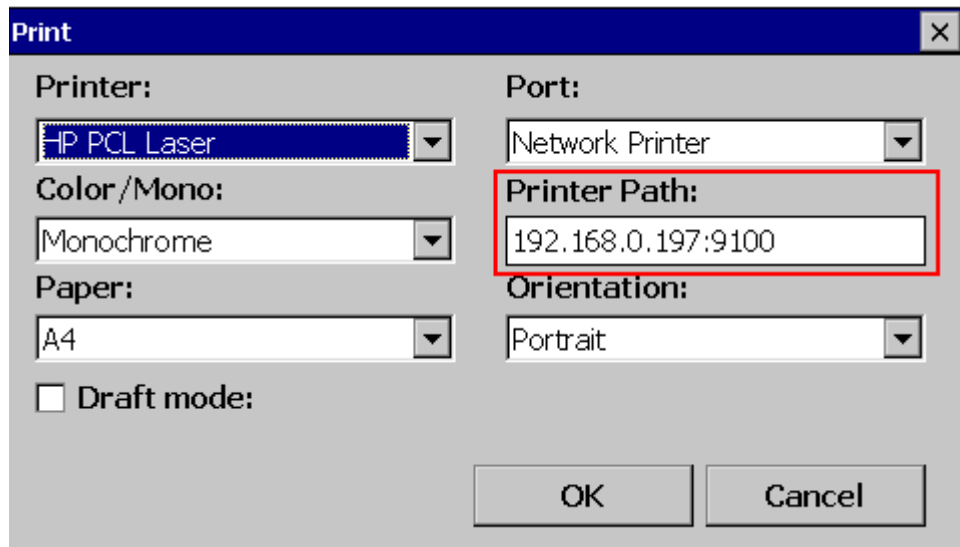

- ❖ For Network Printer set the path as below format
\\IP address of printer: Port no
Example: 192.168.0.197:9100

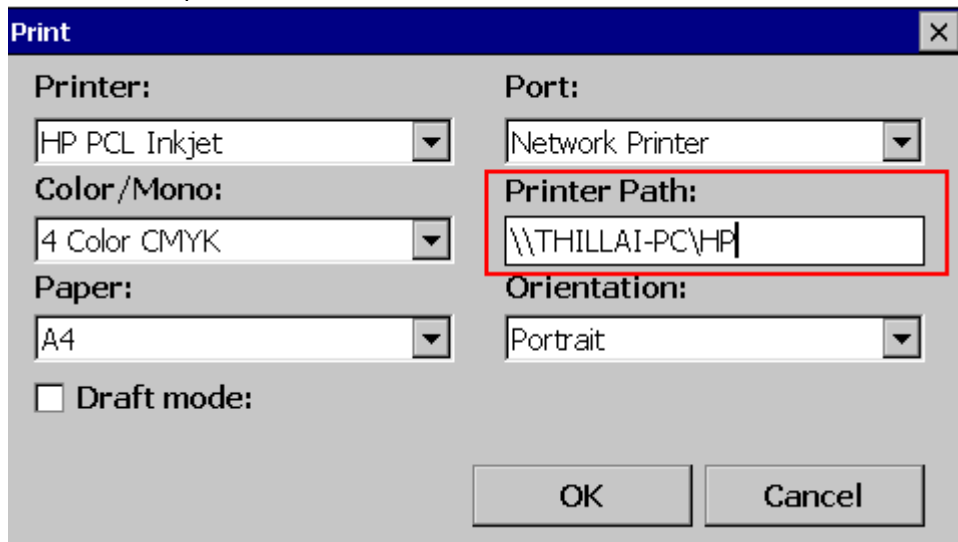

- ❖ For Shard printer set the path as below format
 \PC Name\Printer Share name
 Example: \\THILLAI-PC\HP



4. Press  and then press  soft key to save the configurations. Now the recorder is ready for printer connectivity.
5. Press Menu and Operate to select the print snapshot to test the printer function.

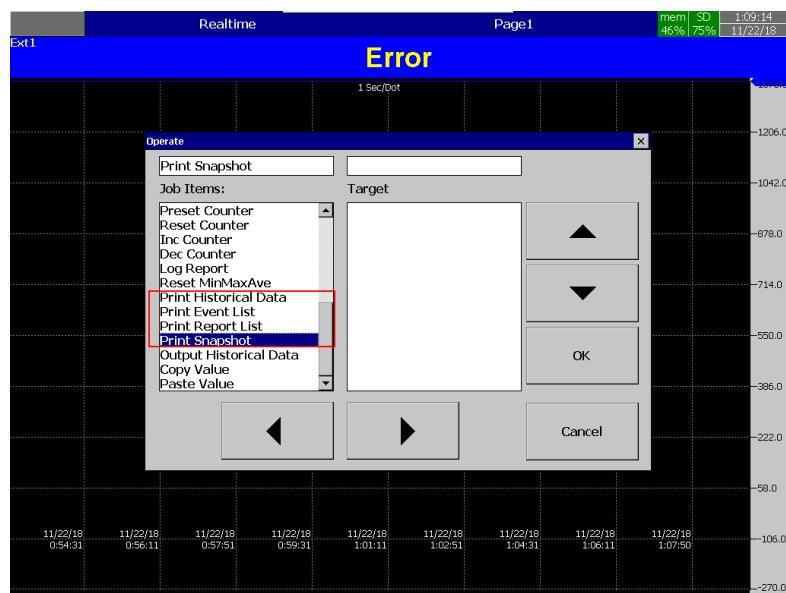
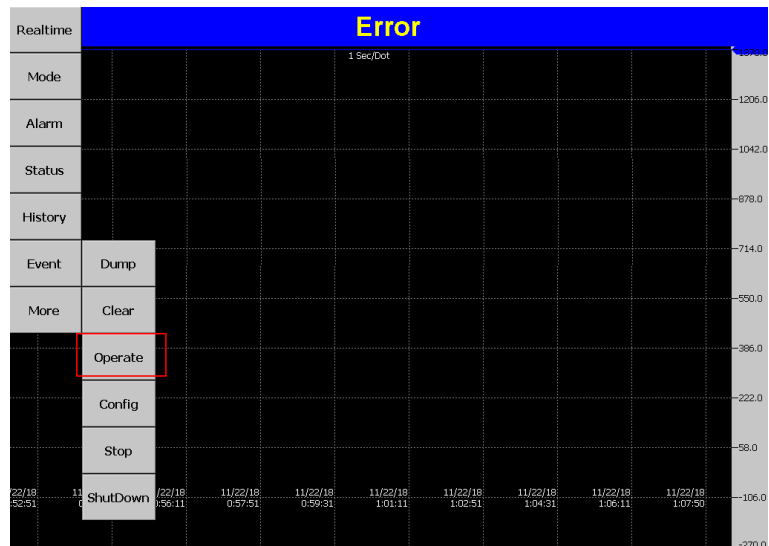



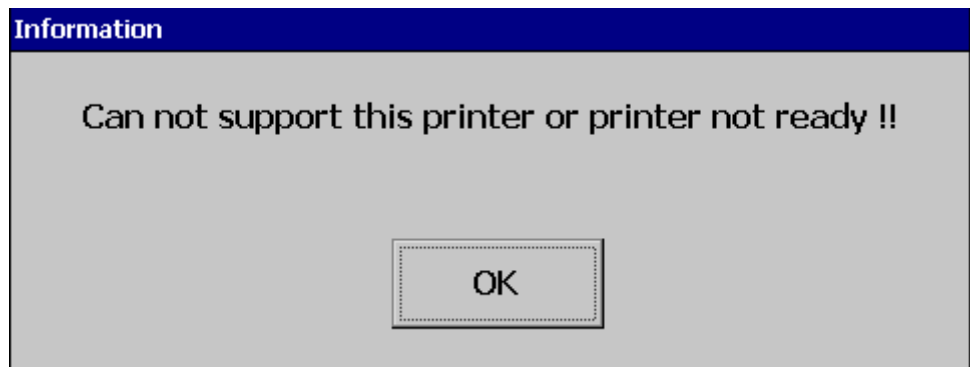

6. If the print job fails to print then the recorder will pop up an error message as below.



5.14 System Information

This will provide the system information for the user like system version, memory information, MAC address, IP address, Connected IO cards in every slots. This page will allow the user to calibrate the touch screen and upgrade the system firmware.

After entering the Configuration menu, select **System Information** then Press the **Enter** key to

get into System Information page. Press directional keys   on the right hand side to move between the information. Press  soft key, then press  soft key to return to main display. All configurations will be saved automatically.

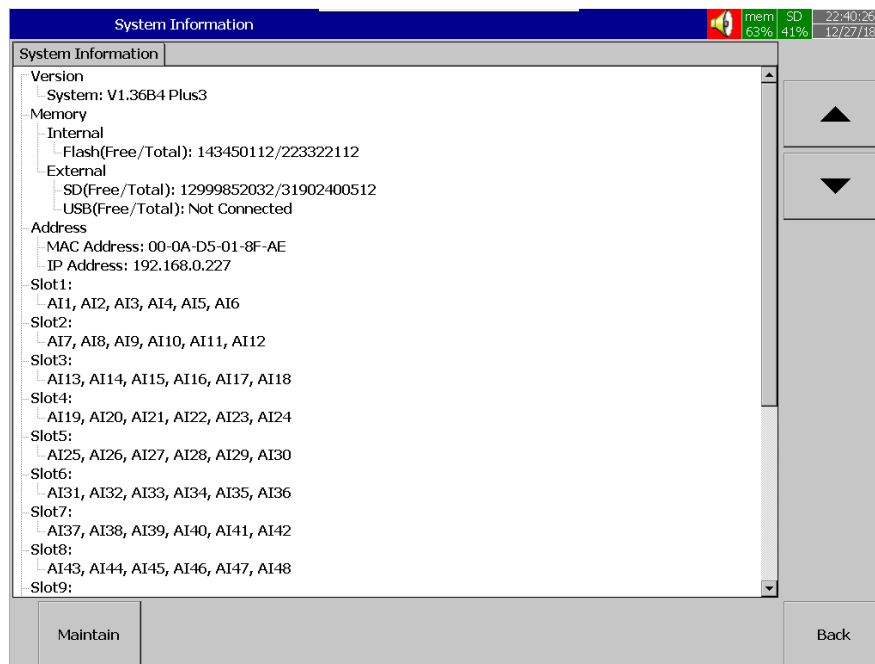

The System Information page contains  soft key to access Touch Screen Calibration and Firmware upgrade Menu.

5.14.1 Firmware Upgrade

The recorder firmware can be updated by using the Update core system option in the maintain menu option. For doing the firmware upgrade follow the below steps.

1. Download the latest firmware from the supplier website.
2. Unzip the file and copy the file Recorder_PV210.Bin file to SD Card or USB Disk as per the selection of External Storage in Instrument menu. The file must be copied to root path of SD Card or USB Disk. The SD Card or USB disk must be formatted to FAT or FAT 32 format.
3. Plug the SD Card or USB Disk to the recorder.
4. After entering the Configuration menu, select **System Information** then Press the **Enter** key to get into System Information page. After entering the System Information Menu, press menu press



key. The system will show the below options to select.

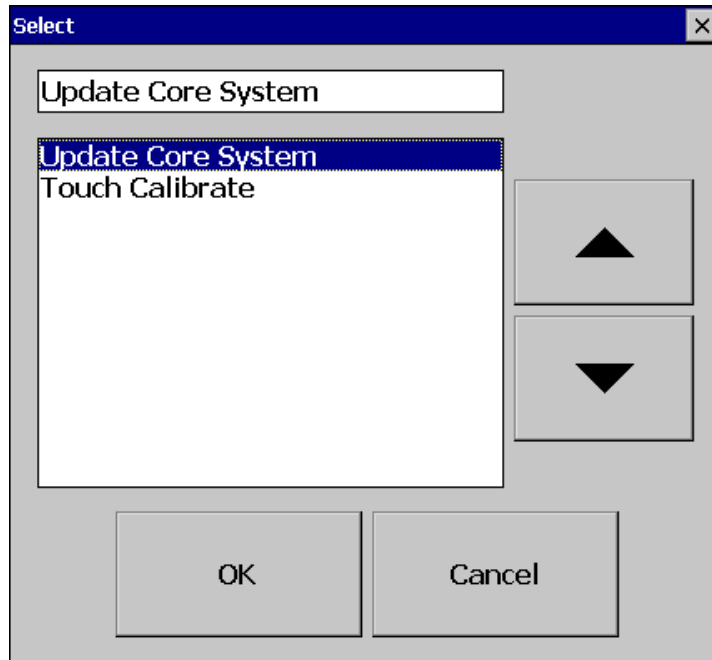

5. Select Update Core System to upgrade the firmware.
6. After the upgrade firmware process is finished the system required to be restarted and do the screen calibration.

Note:

All the data and configuration stored on the recorder will be deleted during the firmware upgrade procedure.

Do not power off the recorder until the upgrade process is finished. Failing to do so may damage the recorder flash memory.

5.14.2 Touch Screen Calibration

After entering the system information menu in configuration menu press  key. The system will show the below options to select.

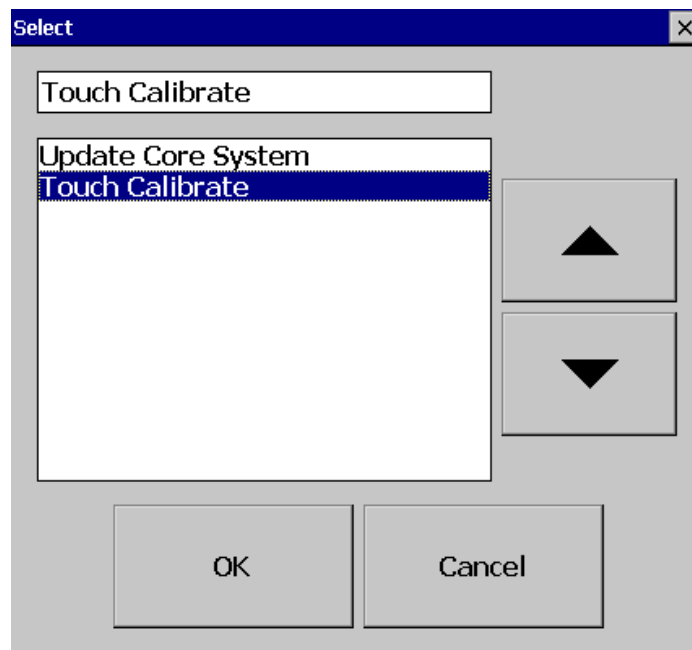

1. Select Touch Calibrate and press OK to do the screen calibration. The below screen will

appear to do the screen calibration.

Carefully press and briefly hold stylus on the center of the target.
Repeat as the target moves around the screen.
Press the Esc key to cancel.



2. A “+” symbol appears in the center of the LCD screen. Carefully press using a stylus or finger on the center of the target.
3. Repeat this procedure as the target moves around the screen. Once the ‘+’ symbol disappears, touch the screen to complete the screen calibration.

By pressing the ESC key from the USB key board connected to the recorder can exit the screen calibration screen. The screen calibration is necessary to achieve proper operation on the screen.

5.14.2.1 Batch Example-1

The operator wants to start a batch every day at 8.00am and stop the batch at 12.00am.

Configuration

Timer1

Type: Daily Action: Enable
Time – Hour: 8 Min: 0 Sec: 1
Job1: Start
Job2: No Action

Timer2

Type: Daily Action: Enable
Time – Hour: 12 Min: 0 Sec: 1
Job1: Pause
Job2: No Action

5.14.2.1.1 How to view batch data in Recorder

Press on  (Menu)-History-Page1

Press “Search”, select required Batch and press “Ok”

Batch details including lot number can be archived by pressing soft key “Batch”

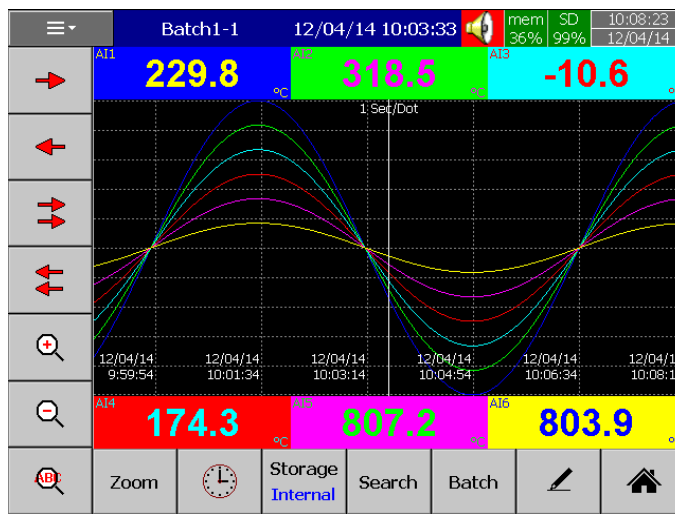
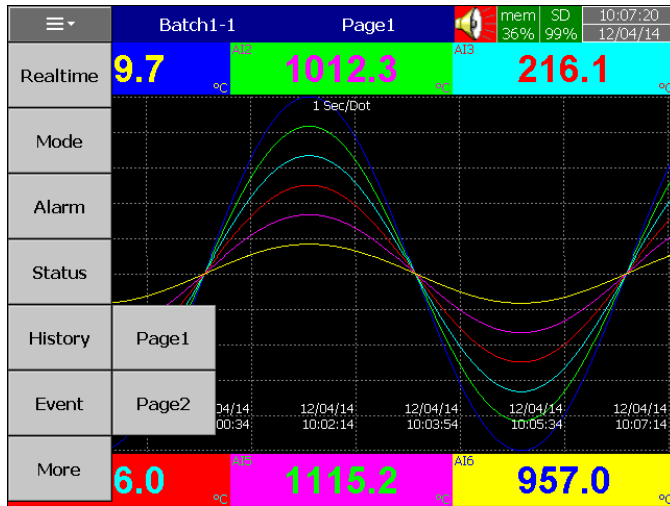

Select (10/20/13 18:55:13) [X]

Batch1-1

Batch1-1

Batch1-2

▲

▼

OK Cancel

5.14.2.1.2 How to Dump Batch data to external USB memory

Press on  (Menu)-More then press on Dump

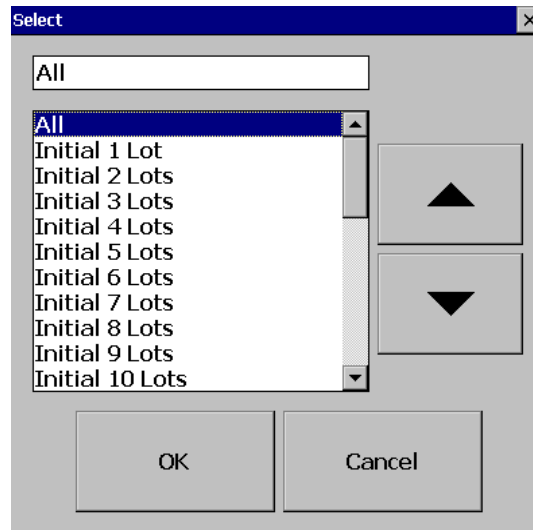

Select "All" or required lots and press "OK"

For ex: Batch 1-1, Batch 1-2, Batch1-3 are available

Initial 1 Lot means, Batch 1-1

Initial 2 Lots means, Batch 1-1 and Batch 1-2

Initial 3 Lots means, Batch 1-1, Batch 1-2 and Batch 1-3

Note: Provision not available to dump only specific lot.

Please refer Instrument->Data Transfer-> Transfer and Remain

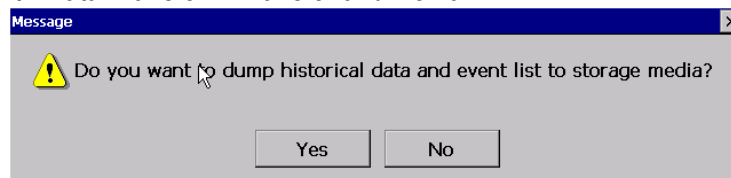

Press on "Yes" to dump data from internal memory to external SD Card or USB memory.

If you have 3 batches, let's say Batch1-1, Batch1-2 and Batch1-3, then you can see three different folders in the external USB memory card after completing of dump

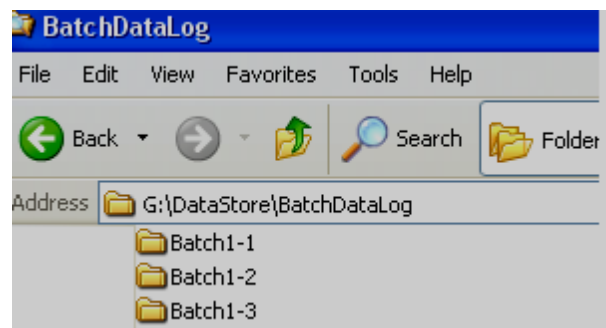



Please note that the data available in USB memory is in a proprietary format to avoid any kind of tampering. You will need PC software to view this data.

5.15 Calibrate

This function is used for calibrating Individual Analog channel. This can be protected by password. After entering the Configuration menu, select **Calibrate** then Press the **Enter** key to get into

Calibration menu. Press directional keys   on the right hand side to select the menu

column. After completing Configuration, press  soft key, then press  soft key to return to main display. All configurations will be saved automatically.

The Calibration must be carried out by a qualified personnel only with proper instruments. The system will show the warning message as shown below when the user is accessing the calibration menu.

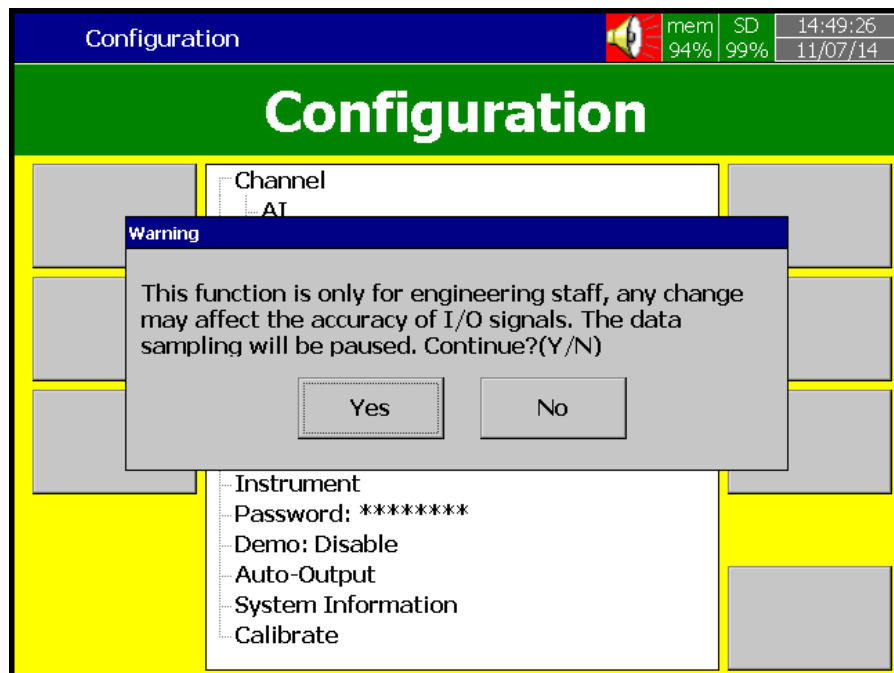

After Entering the calibration menu the screen shows the below screen.

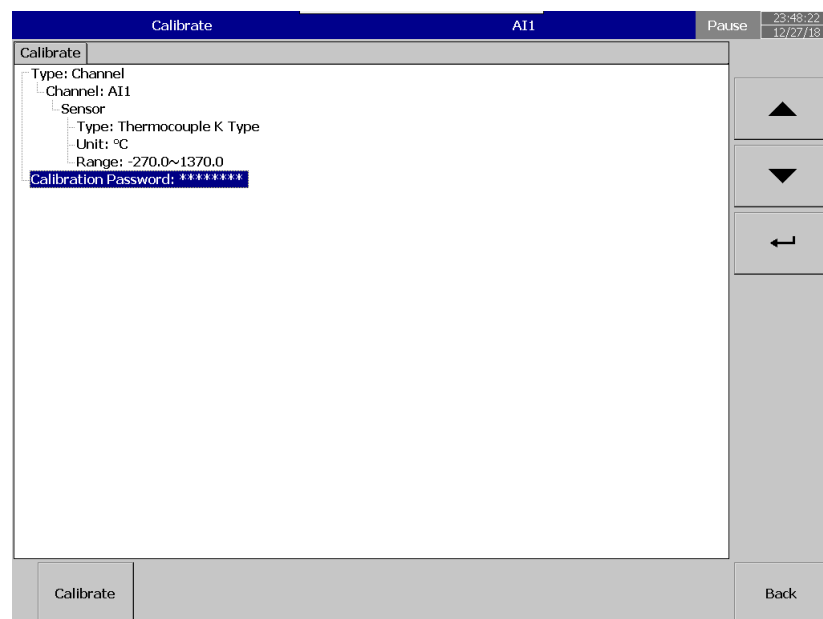

Type: Channel is shown as Type always

Channel: Select the Analog Input or Analog Output Channel from the list to calibrate.

Sensor: Select the input type and its range to be calibrated.

Note:

It is always advisable to do the calibration of 3rd Channel on the card for more accurate calibration.

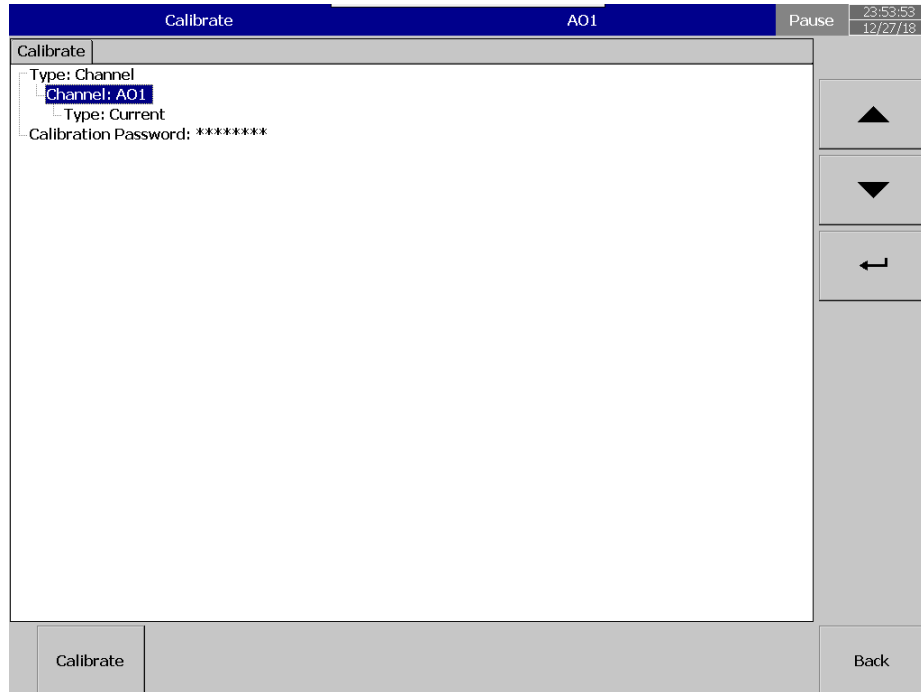

Type: Select the AO type to be calibrated as Voltage or Current.

Note: The AO Card dip switch also need to be set as per the type selection.

Calibration Password: Set Password to access the Calibration parameters.

Note

Channel #3 should be calibrated first in all types of Analog Input cards. An analog temperature sensor is installed in channel # 3. When channel # 3 is calibrating, the cold junction voltage measured by this temperature sensor will be loaded into a register. If channel # 3 is not calibrated, the default value of cold junction voltage will be used for all channels. It does not matter what order you perform calibration after calibrating input 3, there is no need to follow a sequence, and any one of T/C, RTD, mA or VDC can be done independently.

5.15.1 Calibrate an AI with 0-5V

After Entering the Calibration menu, select the channel, input type and range then press calibrate key.

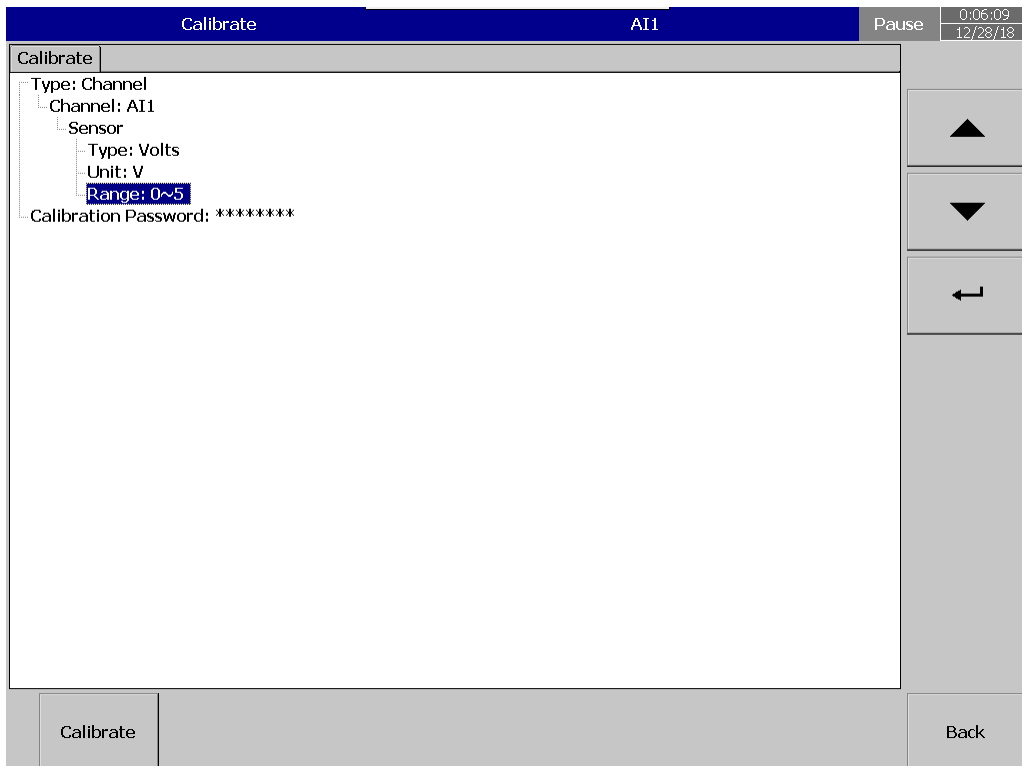

The system will prompt for a user conformation to do the calibration of the channel.

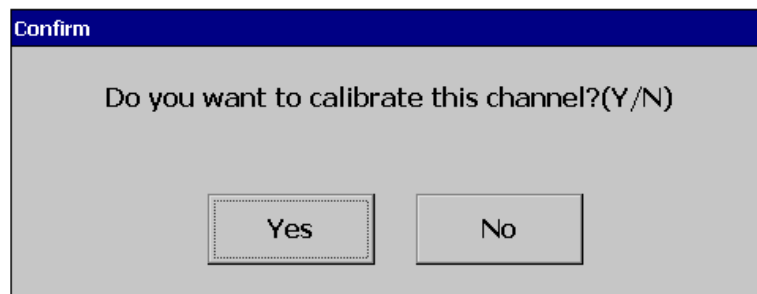

Press Yes to do the Calibration on No to exit. The system will inform the user to input the low value input to the channel.

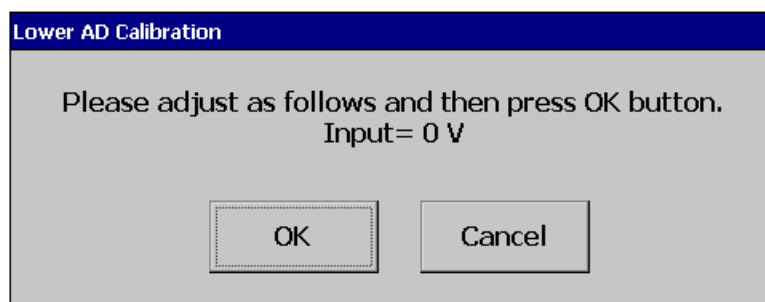

After input 0V, select OK, the user can see the below screen.

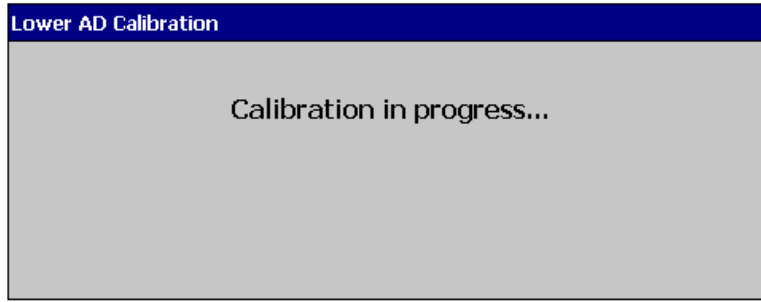

After successful calibration lower AD calibration the system will requests the user to input higher range input to the input channel.

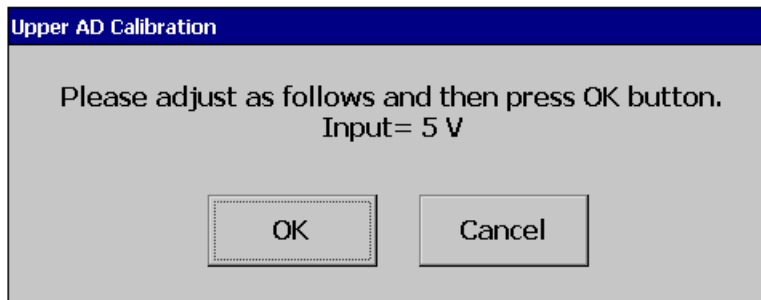

After input 5V, press OK, the user can see the below screen.

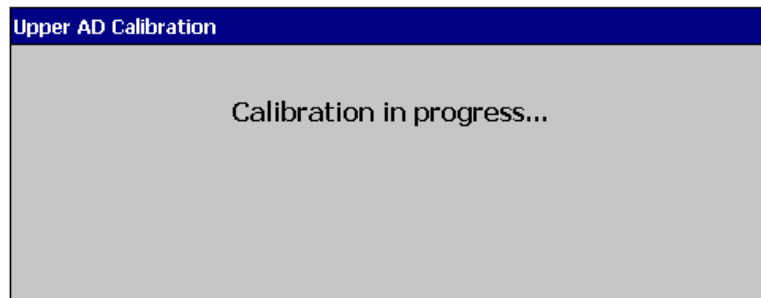

After successful calibration upper AD calibration the system will show the calibration completed message.

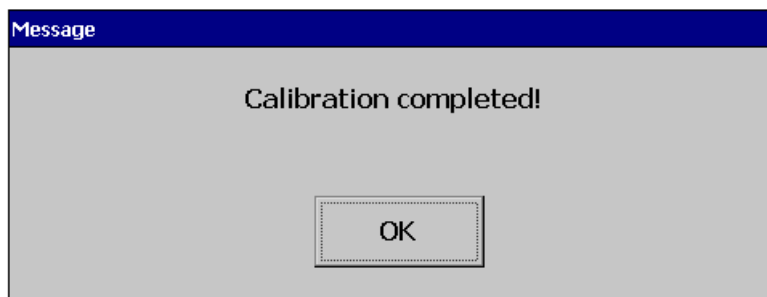

Press Back key to exit the Calibration Menu. The system will prompt the user to save the new calibration or not. Select Yes to apply the new calibration to the channel and No to exit without saving the calibration data.

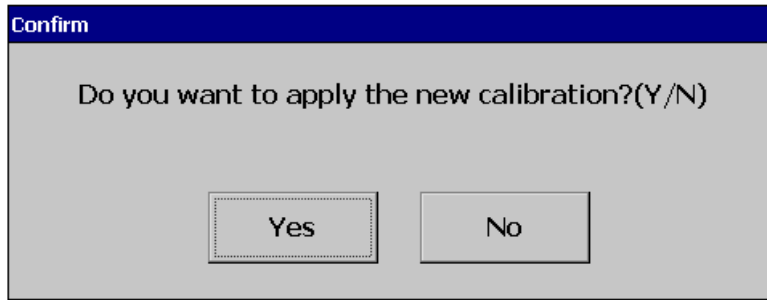

5.15.2 Calibrate an AI with K type Thermocouple

After Entering the Calibration menu, select the channel, input type and range then press calibrate key.

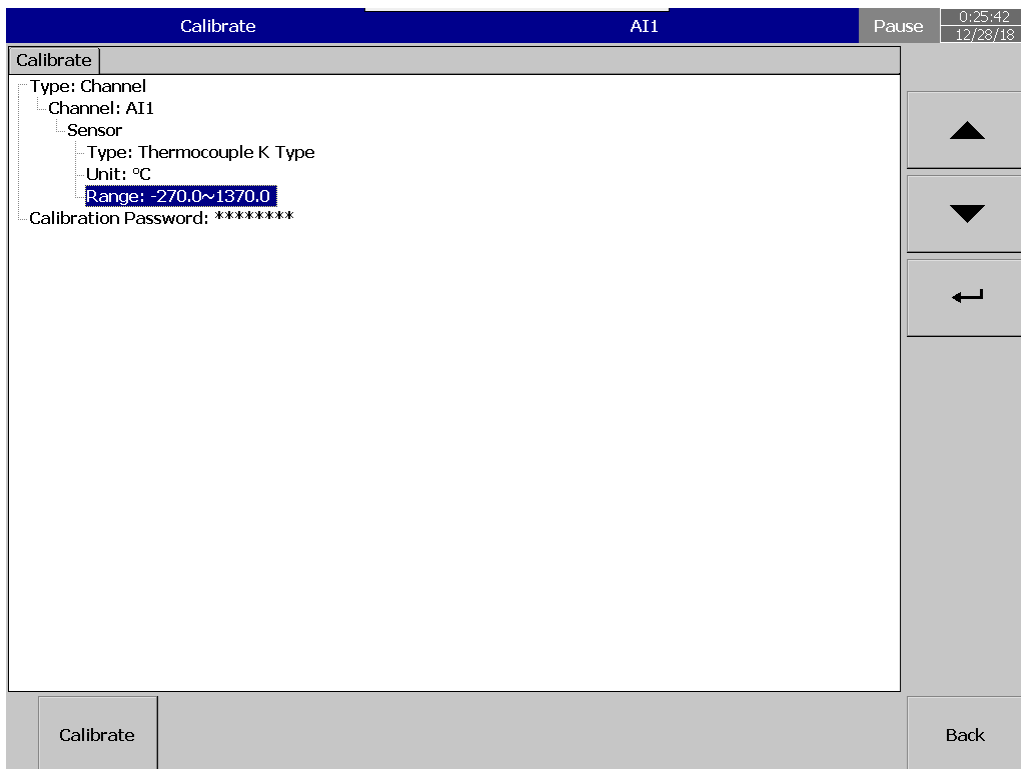

The system will prompt for a user confirmation to do the calibration of the channel.

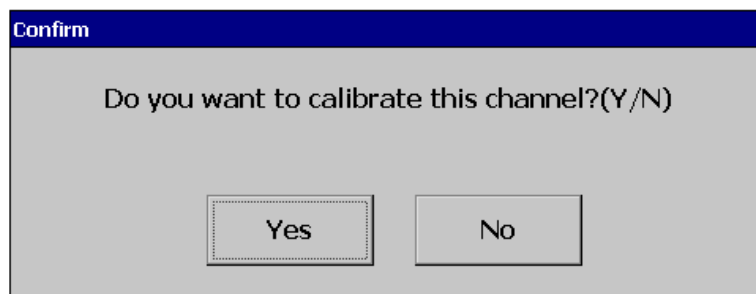

Press Yes to do the Calibration on No to exit. The system will inform the user to input the low value input to the channel.

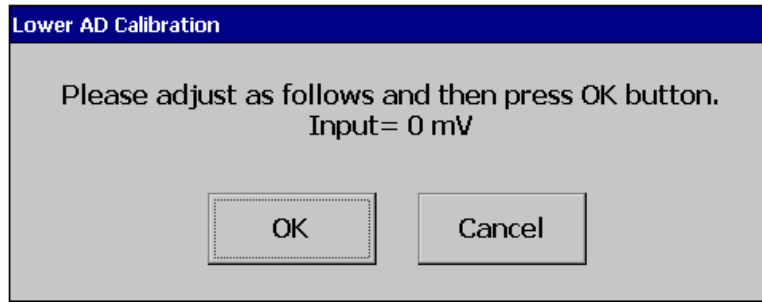

After input 0mV, select ok, the user can see the below screen.

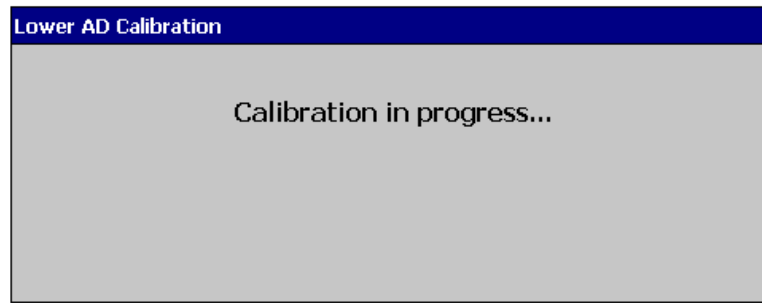

After successful calibration lower AD calibration the system will requests the user to input higher range input to the input channel.

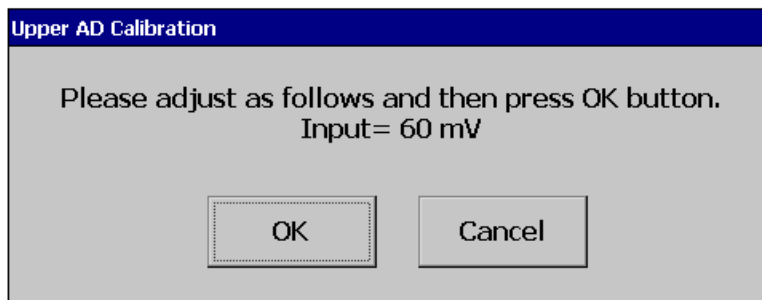

After input 60mV, press OK, the user can see the below screen.

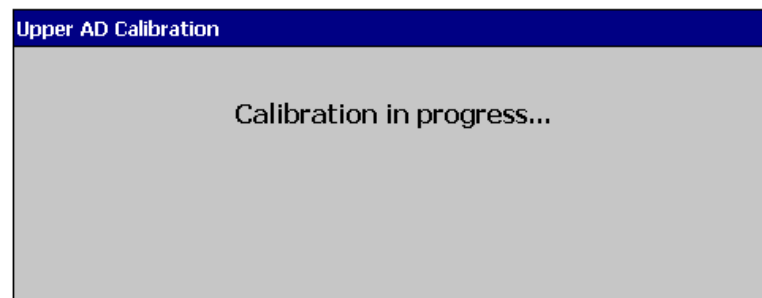

After successful calibration upper AD calibration the system will show the calibration completed message.



Press Back key to exit the Calibration Menu. The system will prompt the user to save the new calibration or not. Select Yes to apply the new calibration to the channel and No to exit without saving the calibration data.

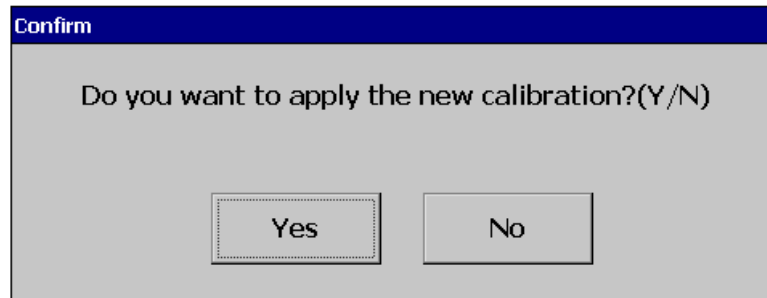

5.15.3 Calibrate an AI with Pt100 RTD

After Entering the Calibration menu, select the channel, input type and range then press calibrate key.

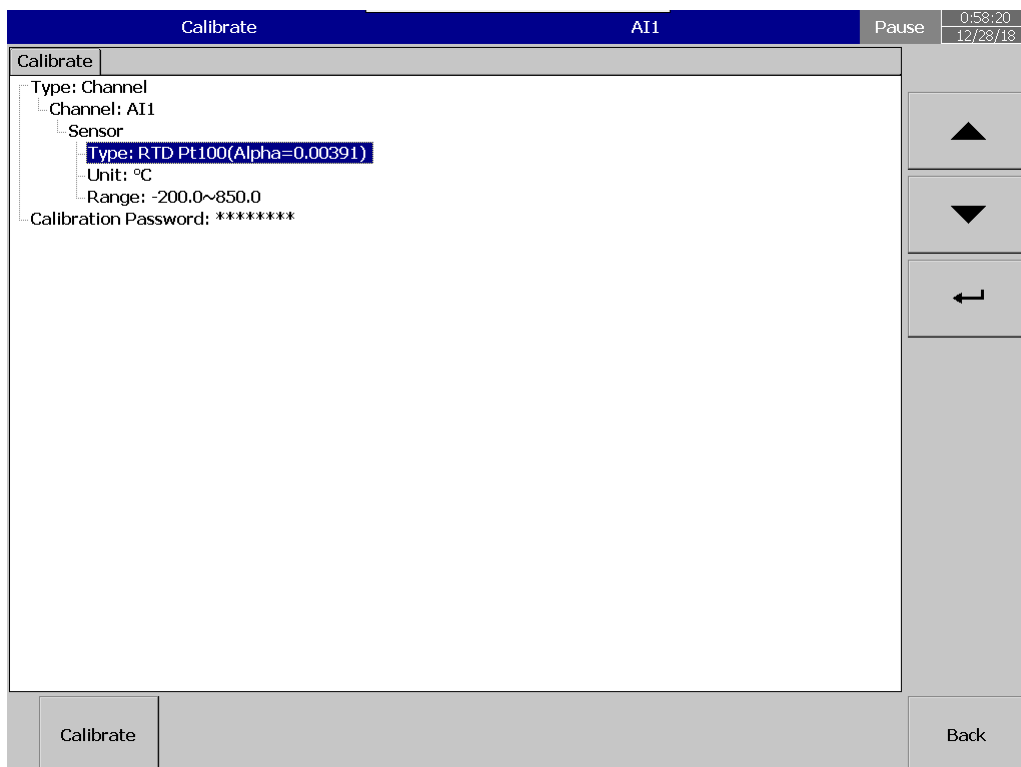

The system will prompt for a user confirmation to do the calibration of the channel.

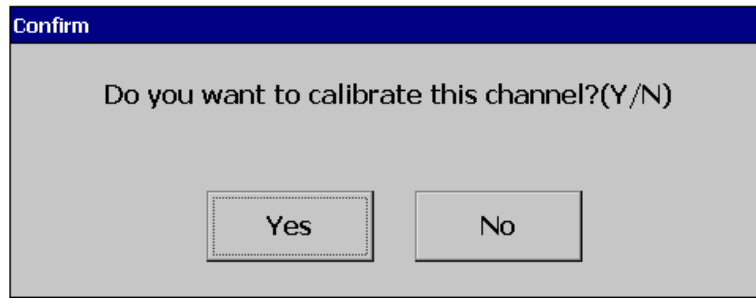

Press Yes to do the Calibration on No to exit. The system will inform the user to input the low value input to the channel.

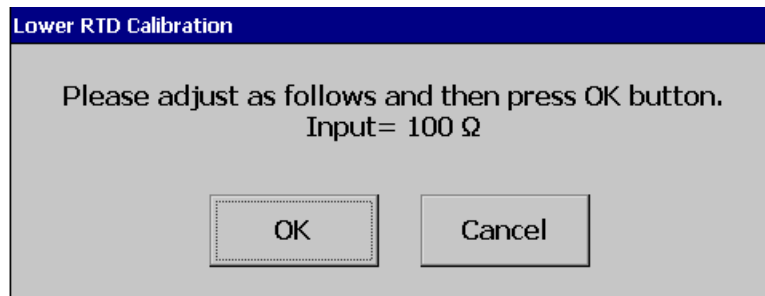

After input 100Ω, select ok, the user can see the below screen.

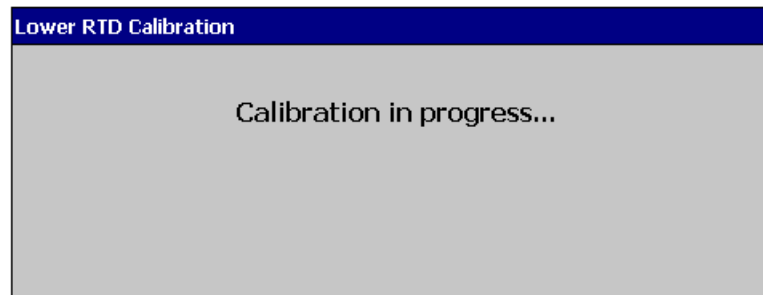

After successful calibration lower RTD calibration the system will requests the user to input higher range input to the input channel.

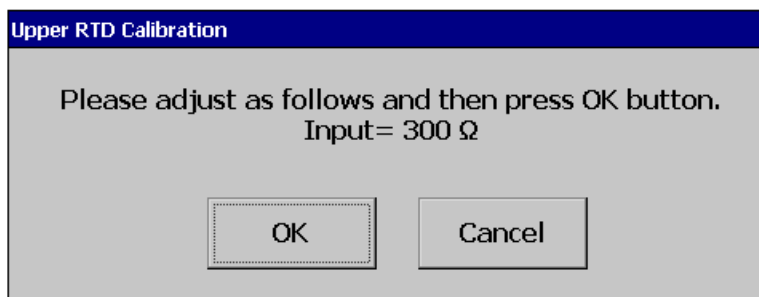

After input 300Ω, press ok, the user can see the below screen.

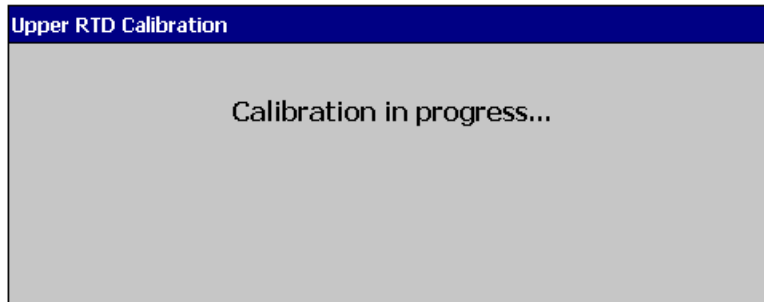

After successful calibration upper RTD calibration the system will show the calibration completed message.

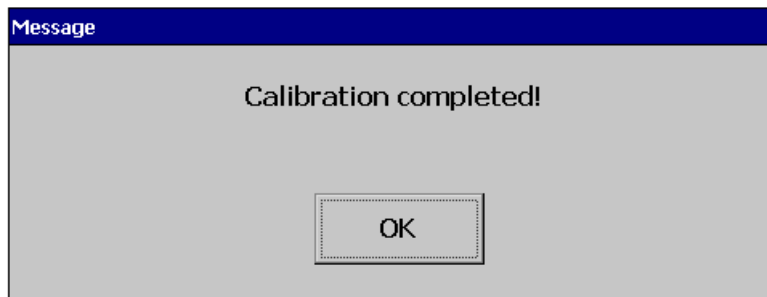

Press Back key to exit the Calibration Menu. The system will prompt the user to save the new calibration or not. Select Yes to apply the new calibration to the channel and No to exit without saving the calibration data.

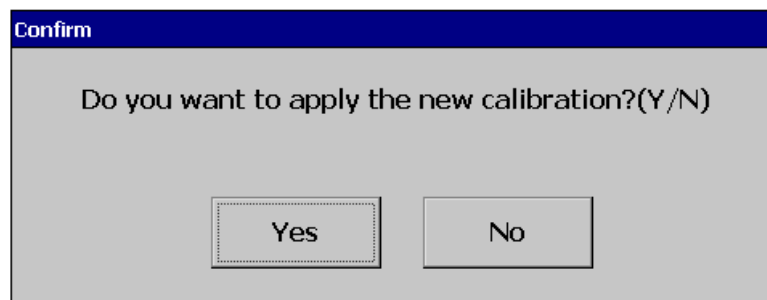

5.15.4 Calibrate an AO with 4 to 20 mA

After Entering the Calibration menu, select the channel, output type then press calibrate key.

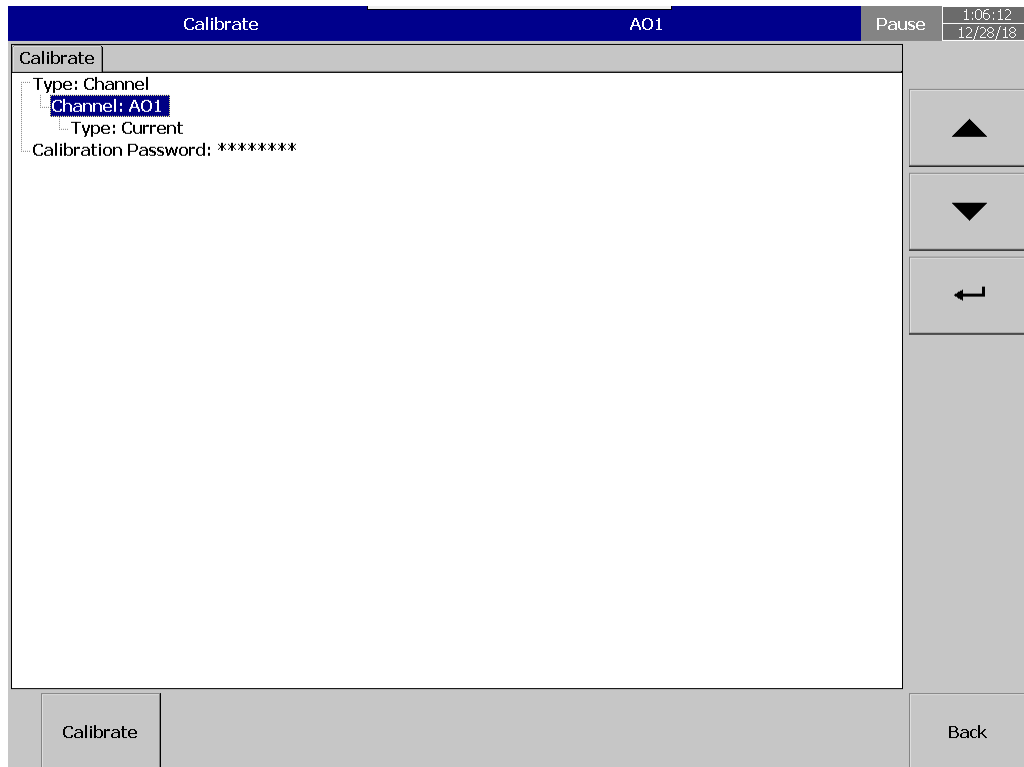

The system will prompt for a user conformation to do the calibration of the channel.

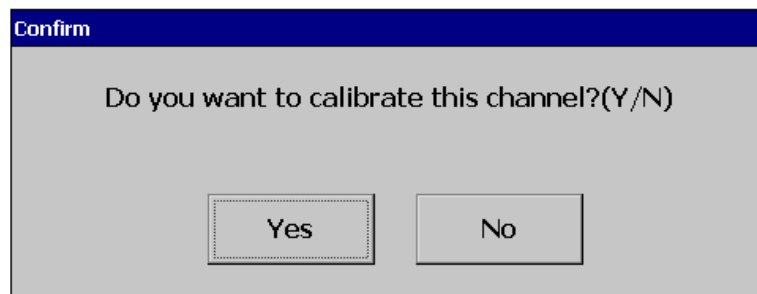

Press Yes to do the Calibration on No to exit.
Connect a Current measuring meter before starting calibration.



The system will inform the user to input the low value input to the channel.

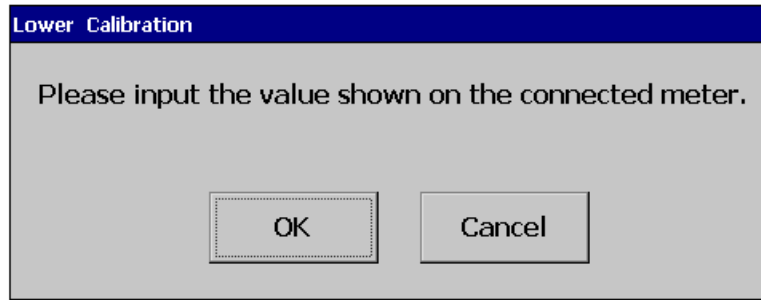

Input the value shown on the meter

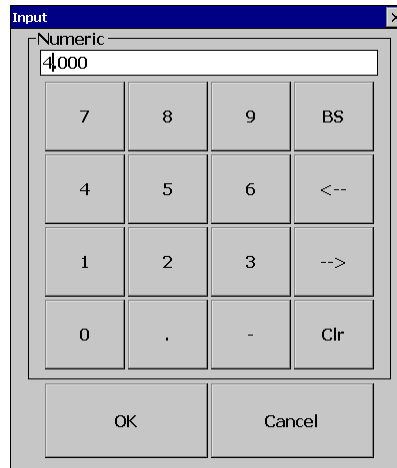

After input the value, the user can see the below screen.

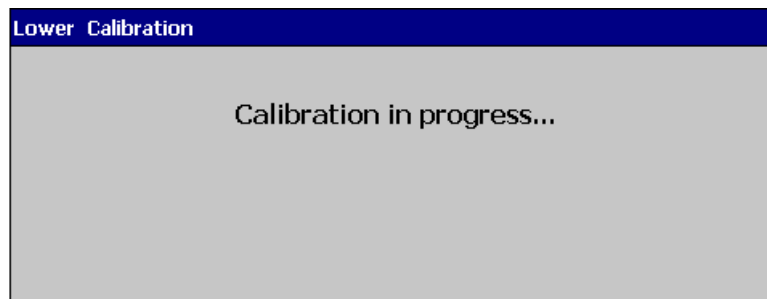

After successful calibration of lower input value the system will requests the user to input higher input to the channel.

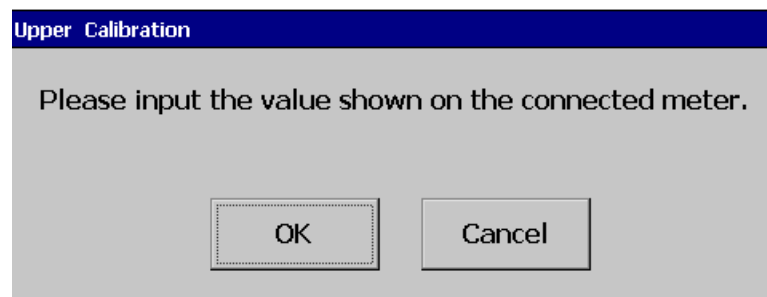

Input the value shown on the meter.

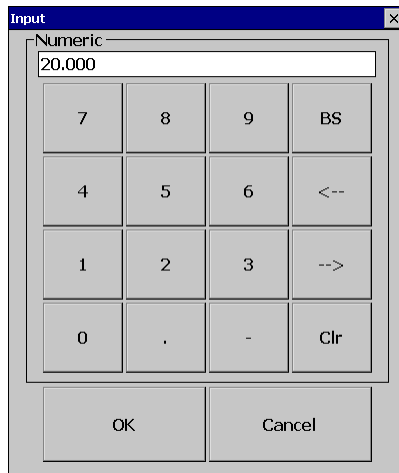

After input the value press OK, the user can see the below screen.

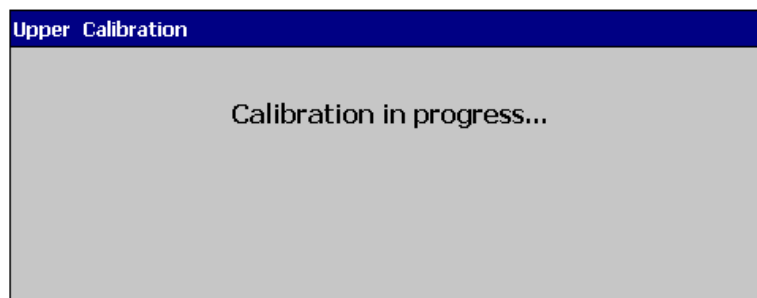

After successful calibration of upper value calibration the system will requests the user to input offset input to the channel.

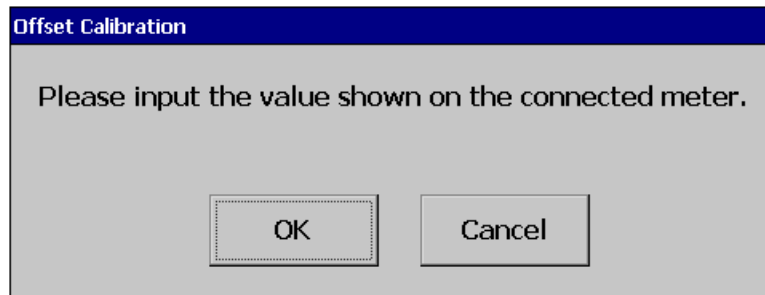

Input the value shown on the meter

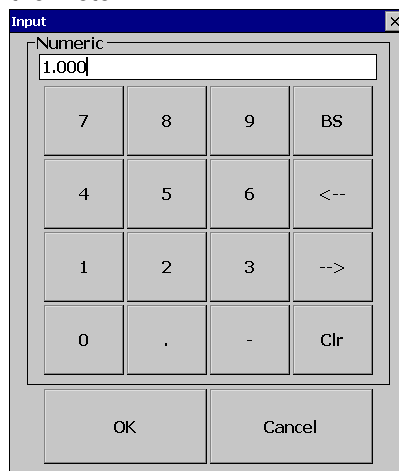

After input the value press ok, the user can see the below screen.

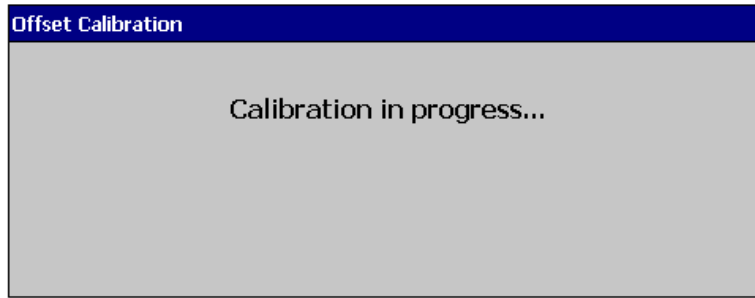

After successful calibration of offset value calibration the system will show the calibration completed message.



Press Back key to exit the calibration Menu. The system will prompt the user to save the new calibration or not. Select Yes to apply the new calibration to the channel and No to exit without saving the calibration data.

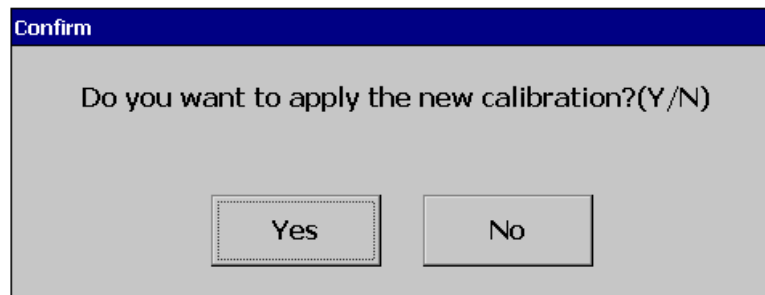

5.15.5 Calibrate an AO with 0 to 10 V

After Entering the Calibration menu, select the channel, output type then press calibrate key.

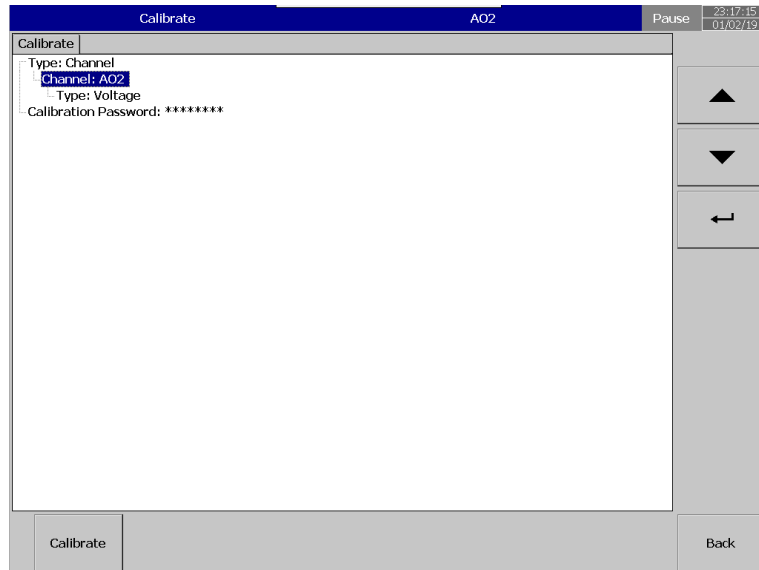

The system will prompt for a user confirmation to do the calibration of the channel.

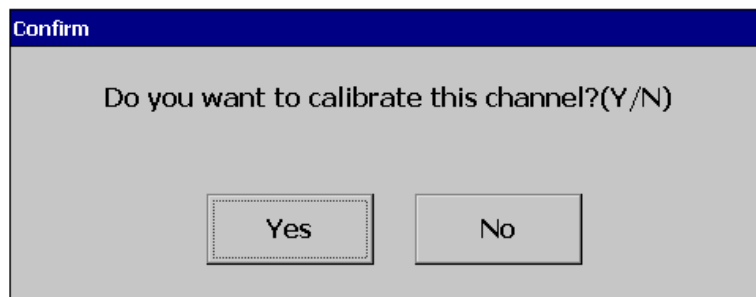

Press Yes to do the Calibration on No to exit.
Connect a Voltage measuring meter before starting calibration.



The system will inform the user to input the low value input to the channel.

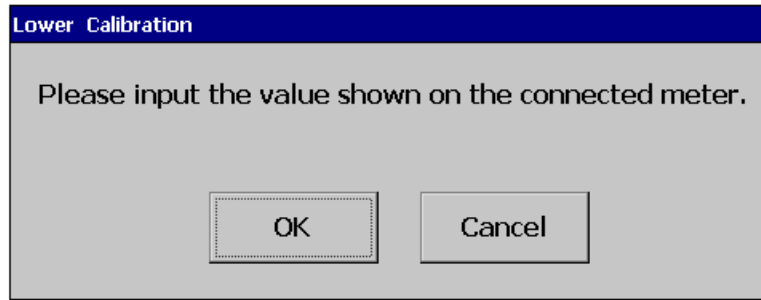

Input the value shown on the meter

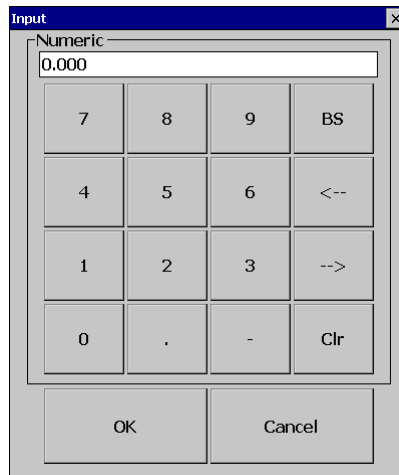

After input the value, the user can see the below screen.

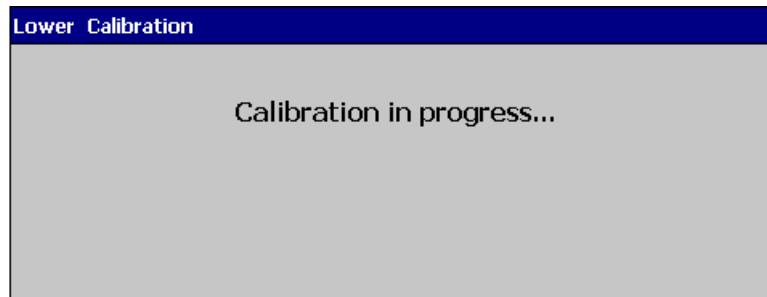

After successful calibration of lower input value the system will requests the user to input higher input to the channel.

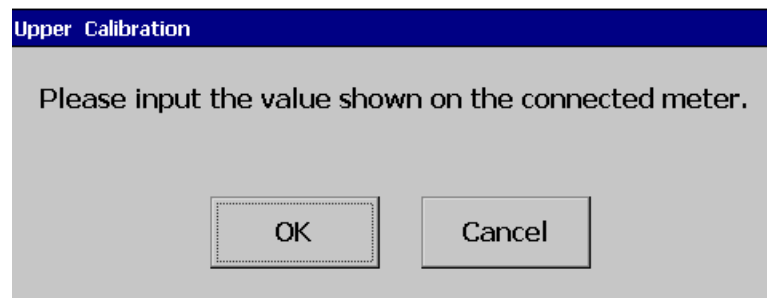

Input the value shown on the meter.

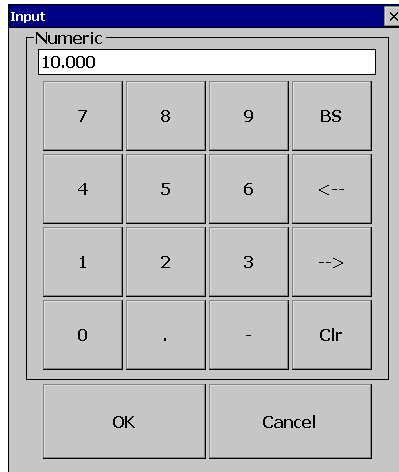

After input the value press OK, the user can see the below screen.

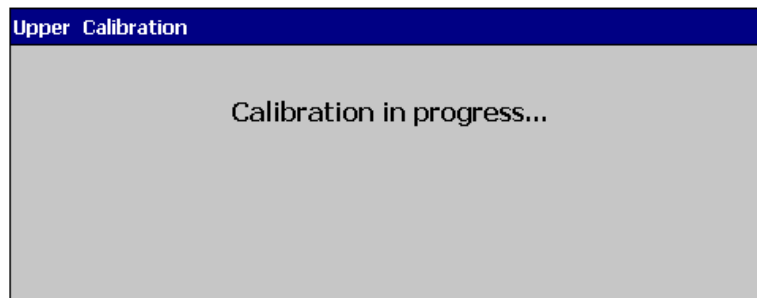

After successful calibration of upper value calibration the system will requests the user to input offset input to the channel.

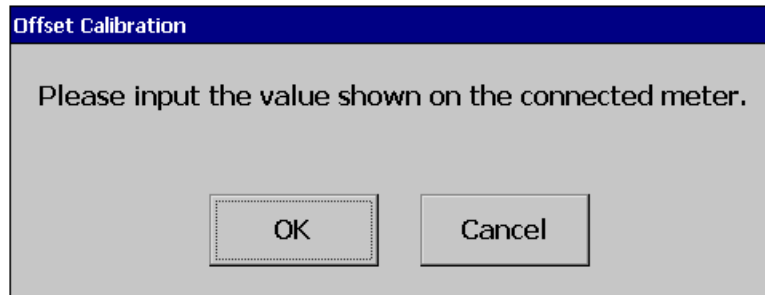

Input the value shown on the meter

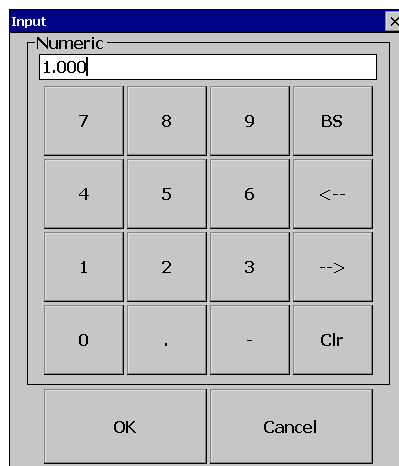

After input the value press OK, the user can see the below screen.

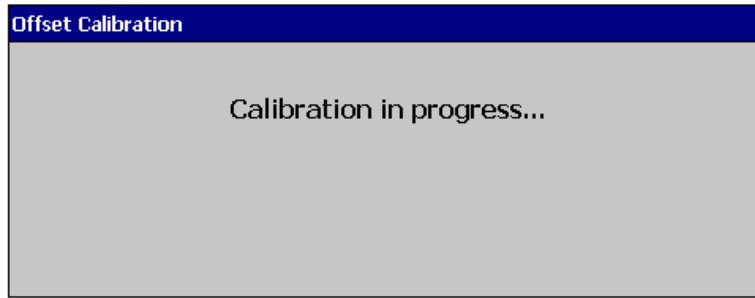

After successful calibration of offset value calibration the system will show the calibration completed message.

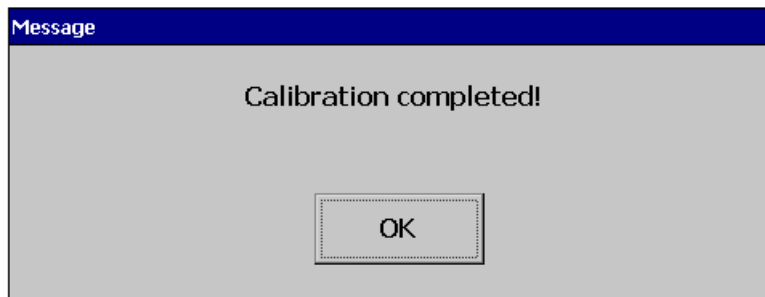

Press Back key to exit the Calibration Menu. The system will prompt the user to save the new calibration or not. Select Yes to apply the new calibration to the channel and No to exit without saving the calibration data.

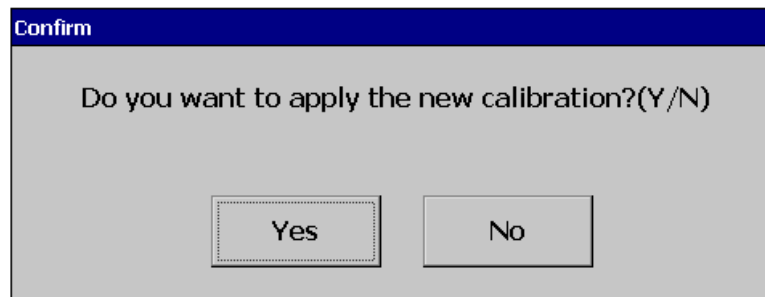

5.16 Procedure to Upgrade and Restore Factory Default Settings

This procedure will allow the user to recover the device when the recorder application is not running or malfunctioning like hanging. The below procedure should be followed to recover the device. Power ON the Recorder while Pressing the Reset Button

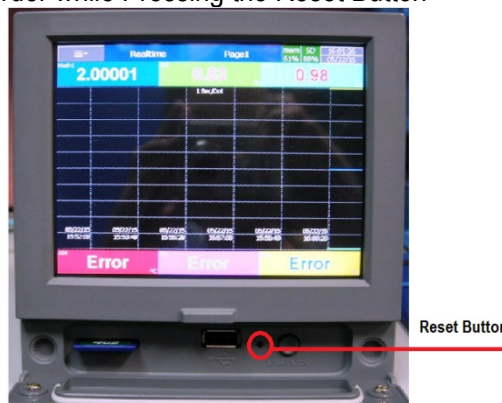

Now the Screen will appear like below

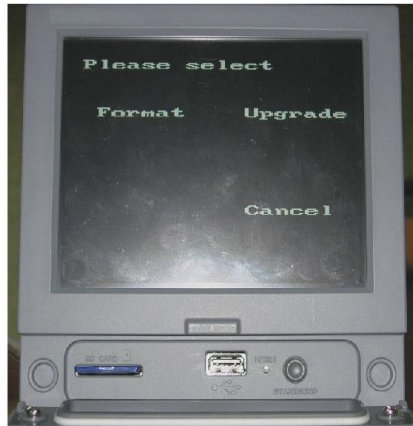
**Format:**

Press the Format Button for at least 3 Seconds to return the Recorder to factory Settings. After the Recorder is done formatting, it will ask for Screen Calibration. Do the Screen Calibration by touching the '+' symbol on the screen. Repeat the step of calibration as long as the symbol '+' moves on the screen. Once the calibration is finished touch the screen to exit. The recorder has now been returned to factory default settings.

Upgrade:

Download the Firmware from the link given. Generally the file will be compressed. The compressed file needs to be unzipped then copy the file Recorder_PV210.BIN to the main path of SD Card. Ensure that the SD card is formatted to FAT32 or FAT. Insert the SD Card to the SD Card Slot on the Recorder. Press Upgrade Button for at least 3 Seconds to upgrade the image from SD Card. Follow the on-Screen instructions.

After the Recorder is done upgrade, it will ask for Screen Calibration. Do the Screen Calibration by touching the '+' symbol on the screen. Repeat the step of calibration as long as the symbol '+' moves on the screen. Once the calibration is finished touch the screen to exit the calibration mode and enter into the recorder application.

6. PC BASED SOFTWARE

The PC Software can be used for configuration of recorder, viewing and analysing of historical data, real time monitoring and logging of data, custom screen development for recorder. There are 4 software available for these functions as listed below.

1. Configuration Viewer- For Configuration
2. Historical Viewer- For analysis and viewing of historical data
3. Real time Viewer-For real time monitoring and logging
4. Panel Studio- For custom screen development

6.1 Free Basic Software

The free basic software provided with recorder consists of Configuration Viewer and Historical Viewer.

6.1.1 Historical Viewer Software Installation

The Historical Viewer software installation will install Historical Viewer and Configuration Viewer on the PC.

6.1.1.1 System Requirements

Item	Minimum Requirements
System	IBM PC compatible computer with Intel Pentium IV or above
Operating System	Windows XP or above
Memory	1 GB
Hard Disk	50 GB Free Space on the hard disk
Communication Ports	RS232 or RS485 or Ethernet Port
Others	USB Port or SD Card Slot

6.1.1.2 Software Installation

The Historical viewer software can be installed by following the below procedure.

1. Download the Historical viewer software form the manufacturer's website.
2. Install latest dot Net software from Microsoft website
3. Install the software by double clicking the setup wizard.exe from Historical Viewer folder.

Historical Viewer				
Name	Date modified	Type	Size	
Historical Viewer Setup	26-11-2018 11:48	File folder		
Microsoft Dot Net	26-11-2018 11:48	File folder		
OEM Tool	26-11-2018 11:48	File folder		
Autorun	19-01-2010 09:17	Setup Information	1 KB	
Background	19-05-2010 08:04	BMP File	5,976 KB	
Setup	07-04-2009 13:46	BMP File	4 KB	
SetupReleaseNote	15-11-2018 13:44	Text Document	2 KB	
SetupWizard	05-06-2017 08:58	Application	7,484 KB	
SetupWizard	13-02-2014 10:09	Configuration sett...	3 KB	

4. Select the language for installation and

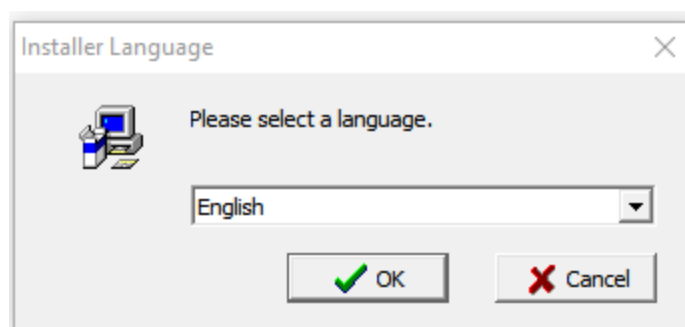

5. Select the software components to be installed and select install

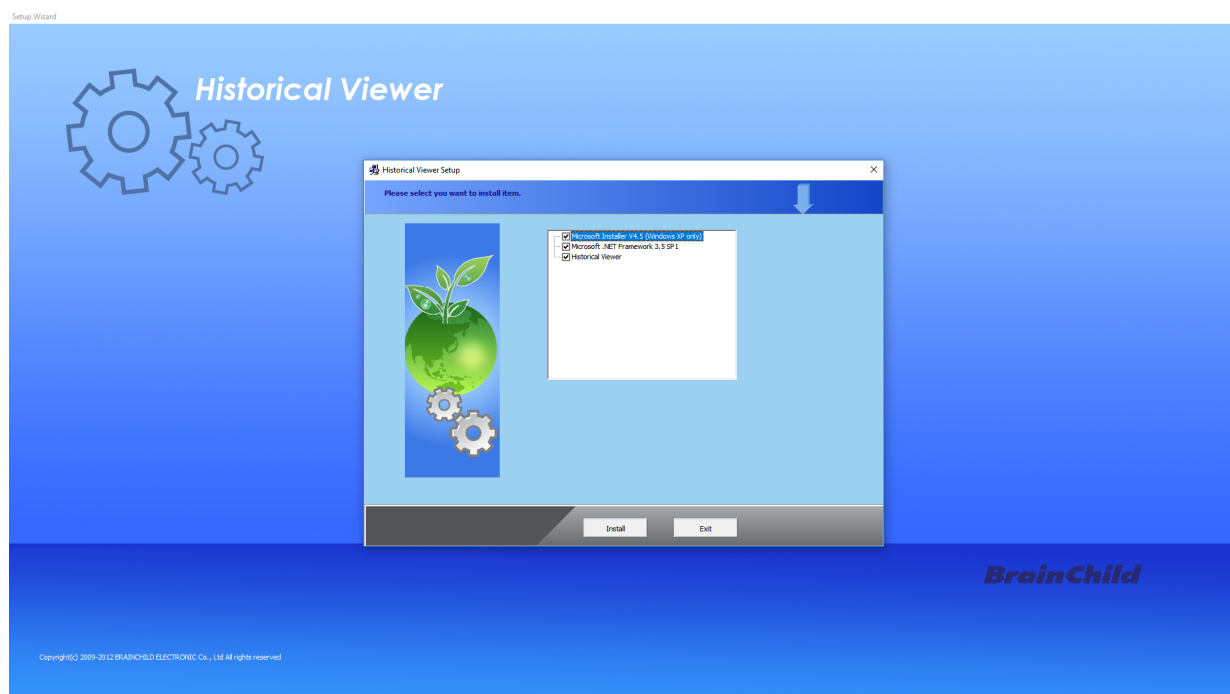

6. Follow on screen instructions to select the installation path and press next to continue the installation.

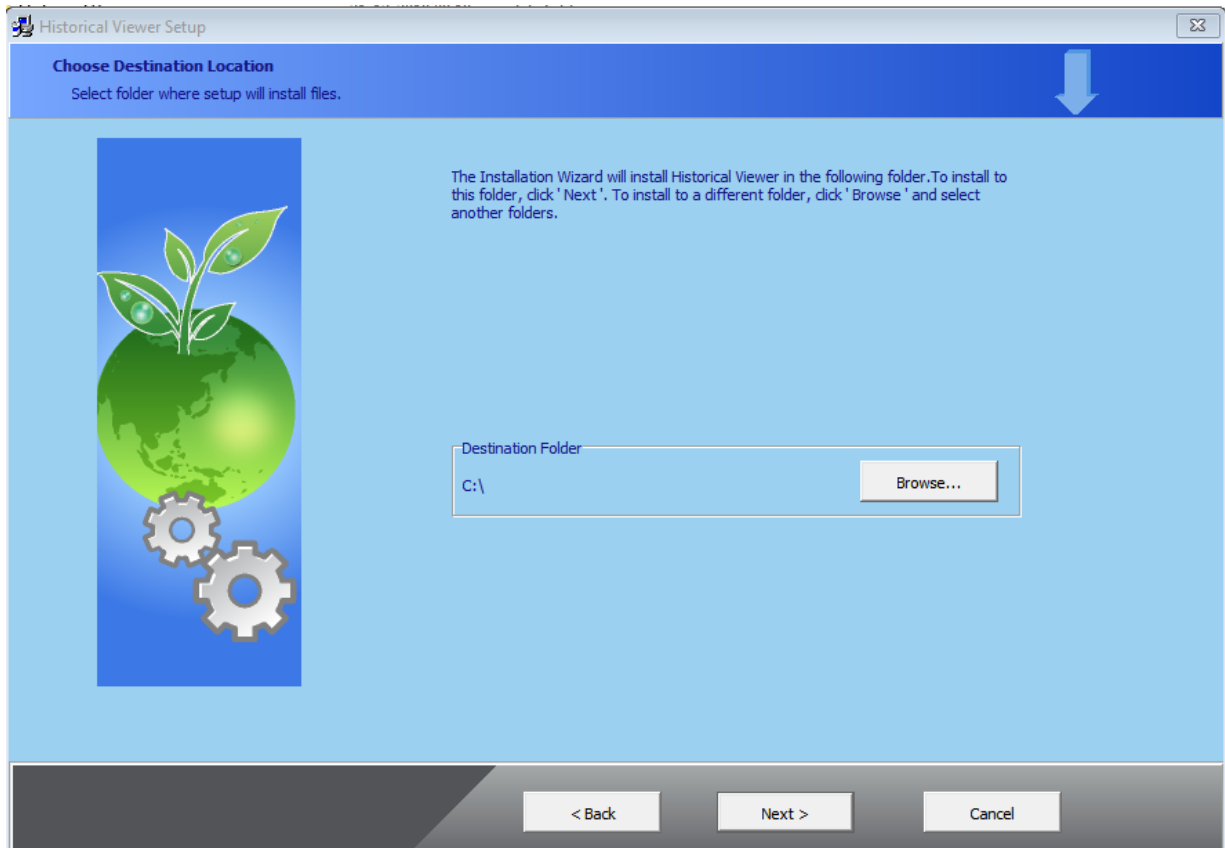

7. Follow onscreen instructions to complete the installation. Once the installation is completed the system will show the installation complete message.

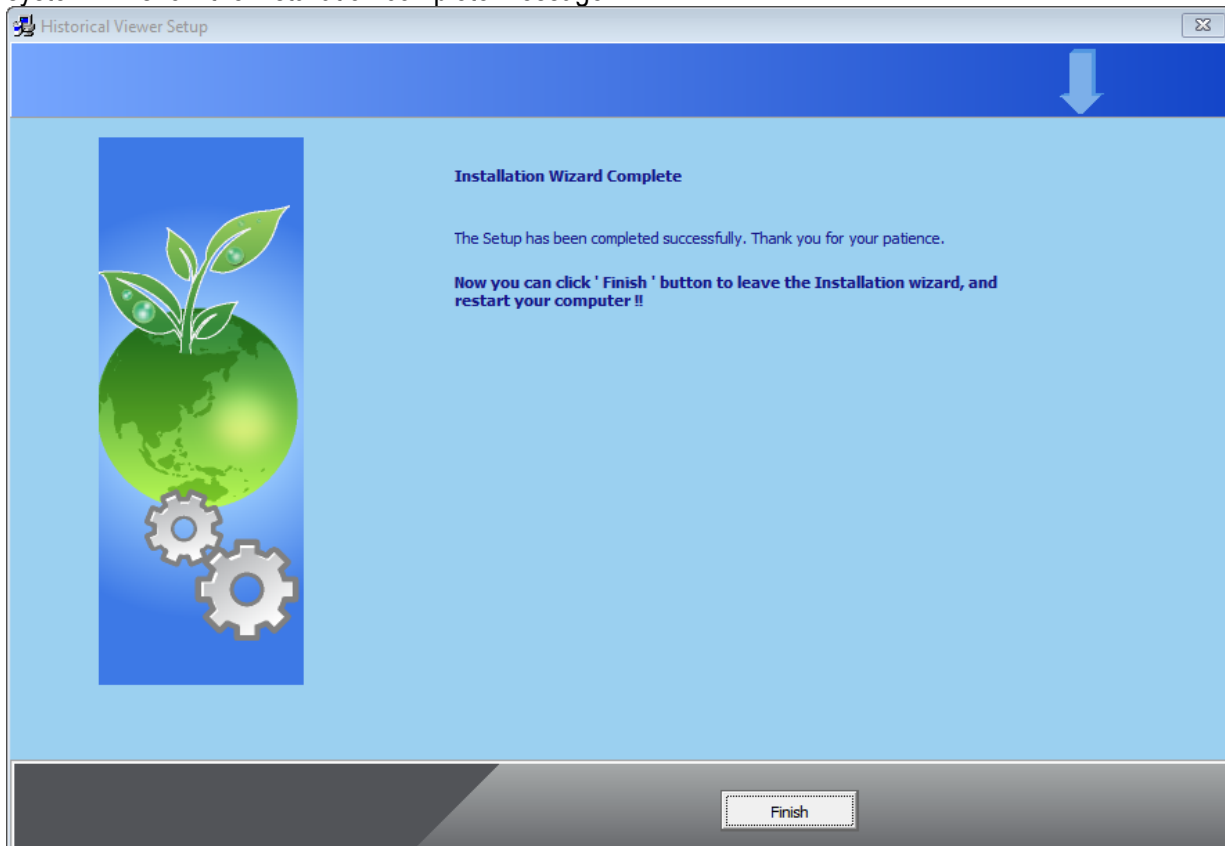

8. After installation is successful, shortcut for Historical viewer software will be created on the desktop.

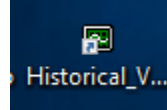

9. The structure of Historical viewer on start menu as below.

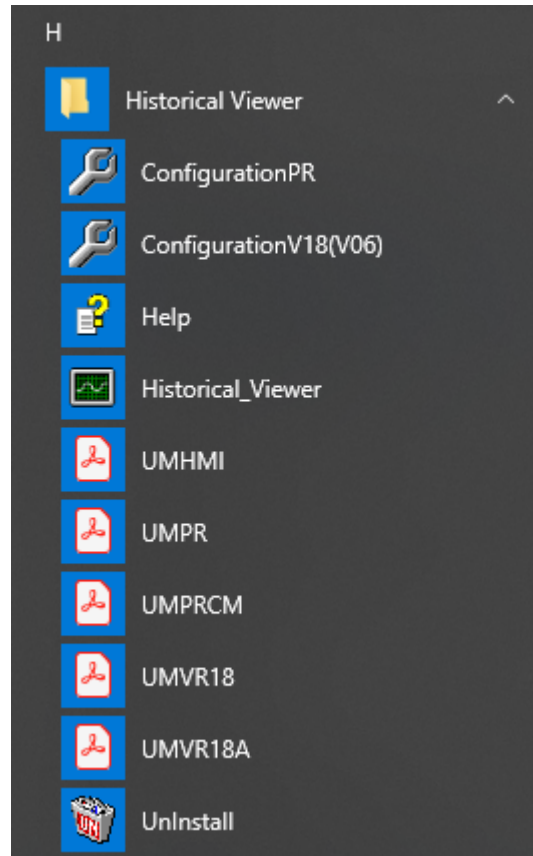

6.1.1.3 Uninstallation of Software

The software can be uninstalled by selecting the uninstall option on the start menu.

6.1.2 Start and Exit

The Historical Viewer program can be start by using the shortcut  on the desktop or selecting the program Historical Viewer from the start menu.

The program can be exit by simply closing the program X symbol on the top right corner of the screen.





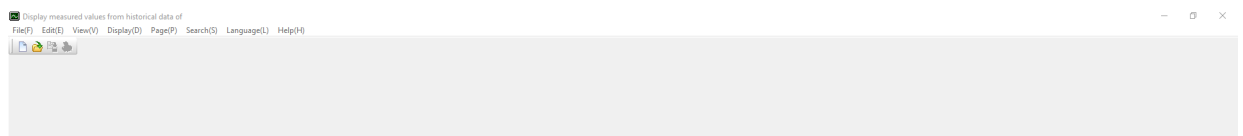























6.1.3 Historical Viewer















When running the program first time the initial screen displays like below.



6.1.3.1 Historical Viewer-Tool Bar

The historical viewer has below tools on the tool bar.

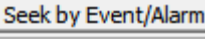
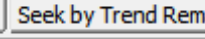
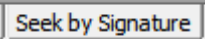
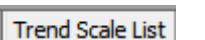
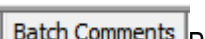
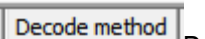
- ✓  New
- ✓  Open
- ✓  Save As
- ✓  Print
- ✓  Trend View
- ✓  Event / Alarm List
- ✓  Report List
- ✓  Value List
- ✓  Manually Export data to Excel
- ✓  Copy Curves to Clipboard
- ✓  Remark
- ✓  Latest Event / Alarm List
- ✓  Manually Export data to Database Format (*.CSV)
- ✓  Snapshot
- ✓  Show Statistics
- ✓  Manually Export data in PDF
- ✓  Search by Specific Time
- ✓  Search by Specific Period
- ✓  Search by Handwrite
- ✓  Fast Backward
- ✓  Backward
- ✓  Forward
- ✓  Fast Forward
- ✓  Zoom In
- ✓  Zoom Out
- ✓  Zoom All
- ✓  Zoom Size
- ✓  Zoom By Time
- ✓  Zoom By Time and Value

- ✓  Select Period (Period A to B)
- ✓  By Horizontally
- ✓  By Vertically
- ✓  White Background
- ✓  Black Background
- ✓  Next Page
- ✓  Manually import measured data
- ✓  Configuration
- ✓  Page Configuration
- ✓  Scale Selection
- ✓  Batch Selection
- ✓  Signature List
- ✓  Logout
- ✓  Seek by Tag Name
- ✓  Seek by Event / Alarm
- ✓  Seek by Trend Remark
- ✓  Seek by signature
- ✓  Trend Scale List
- ✓  Batch Comments
- ✓  Decode Method

6.1.3.2 Historical Viewer-Menu Bar

The menu bar of consists of 8 menus. They are listed as below.

1. File(F)
2. Edit(E)
3. View(V)
4. Display(D)
5. Page(P)
6. Search(S)
7. Language(L)
8. Help(H)

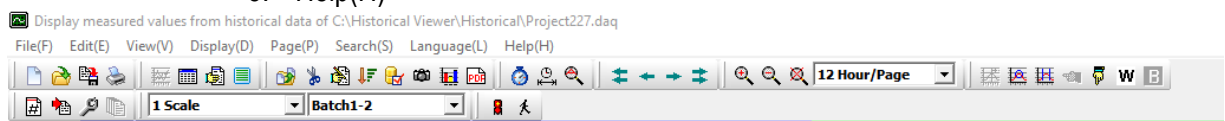

6.1.3.2.1 File (F)

The below are the sub menu options available in File Menu.

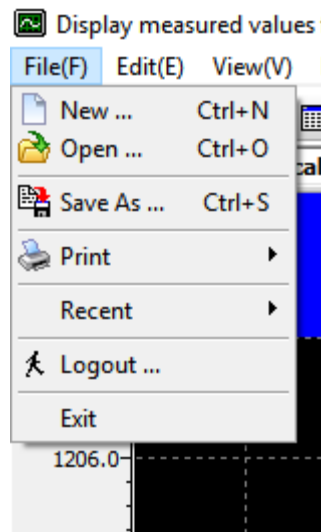

1. **New:** Create a new project.
2. **Open:** Open an existing project.
3. **Save As:** Save the project with a new name.
4. **Print:** Print the data.
5. **Recent:** Open recently opened projects.
6. **Logout:** Log out the current user.
7. **Exit:** Exit the program.

6.1.3.2.2 Edit (E)

The below are the sub menu options available in Edit Menu.

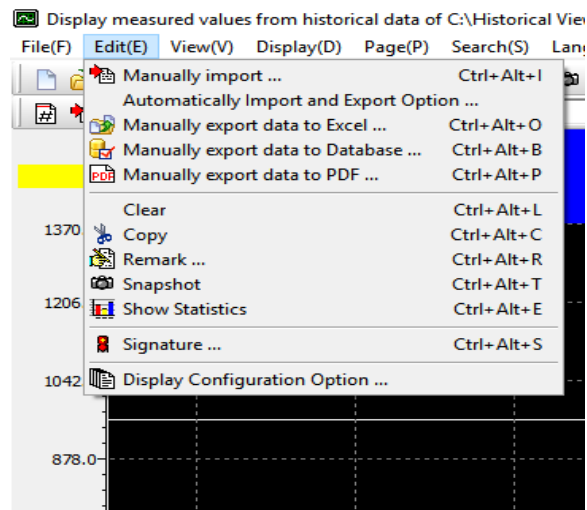

1. **Manually Import:** Manually import the data from the device.
2. **Automatically Import and Export Option:** Automatically import the data from the device and exported to Excel, PDF or Database format
3. **Manually export data to Excel:** Manually export the data to Excel
4. **Manually export data to Database Format:** Manually export the data to the database format .csv

5. **Manually export data to PDF:** Manually export the data to PDF
6. **Clear:** Clear the data from the project for a specific time period or all.
7. **Copy:** Copy the screen
8. **Remark:** Add remark to the data
9. **Snapshot:** Print the snapshot of the trend view.
10. **Show Statistics:** Show the statistical data Min, Max, Ave, P-P, Mean, RMS, Point A, Point B, Difference of point A and point B (A-B) of displayed trend.

Channel	MIN	MAX	P-P	Mean	RMS	A	B	Difference(B-A)
AI1(°C)	-19...	110...	129...	101.4	305.3	0.0	0.0	0.0
AI2(°C)	-18...	128...	147...	123.9	359.9	0.0	0.0	0.0
AI3(°C)	-20...	333.0	535.9	14.7	95.1	0.0	0.0	0.0
AI4(°C)	-10...	639.5	748.9	59.7	177.8	0.0	0.0	0.0
AI5(°C)	0.0	145...	145...	205.1	469.2	0.0	0.0	0.0
AI6(°C)	0.0	130...	130...	192.7	433.3	0.0	0.0	0.0

11. **Signature:** Shows the list of signatures on the data.

No.	Signature	Time	Status	Comment
1	THILLAI	01/04/19 01:21:28	Pass	
2	THILLAI	01/06/19 21:42:54	Pass	

12. **Display Configuration Option:** Select the display configuration as automatically or manually.

6.1.3.2.3 View (V)

The below are the sub menu options available in View Menu.

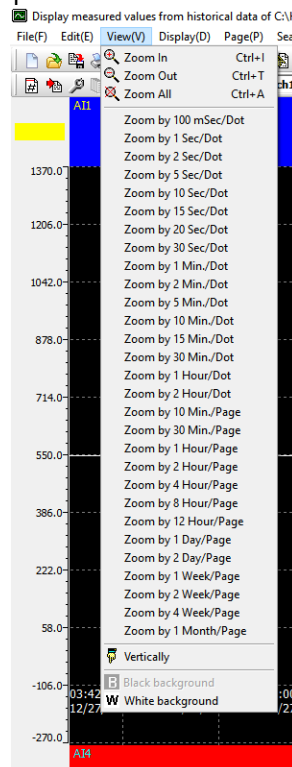

This will allow the user to select the different zoom rate for the data, vertical or horizontal direction of trend and black or white background.

6.1.3.2.4 Display (D)

The below are the sub menu options available in Display Menu.

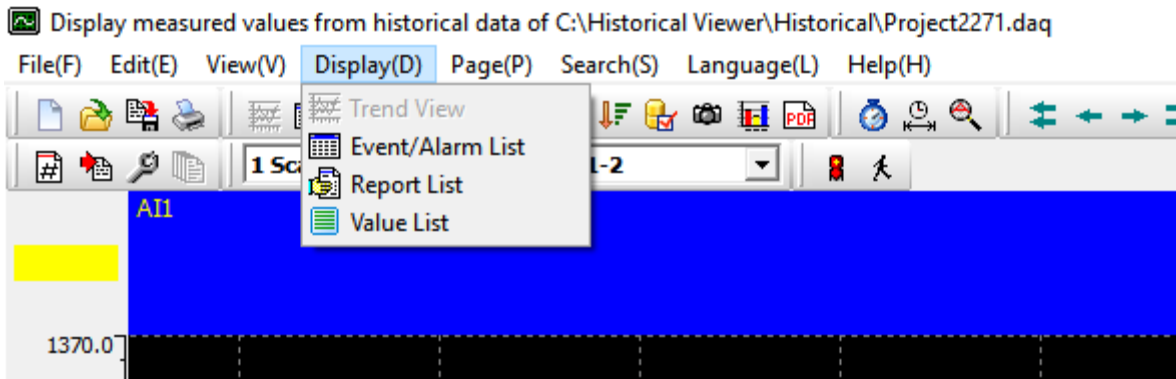

1. **Trend View:** View the data in trend view mode.
2. **Event/Alarm List:** View the Event and alarm List of the data.
3. **Report List:** View the report list of the data.
4. **Value List:** View the data in Value List mode.

6.1.3.2.5 Page (P)

The below are the sub menu options available in Page Menu.

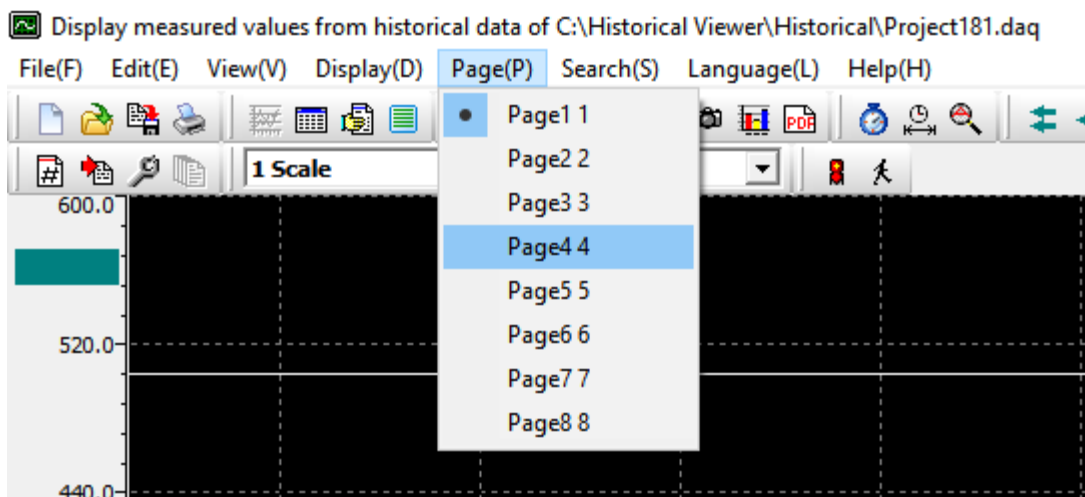

The user can select the display page to be viewed from the shown list.

6.1.3.2.6 Search (S)

The below are the sub menu options available in Search Menu.

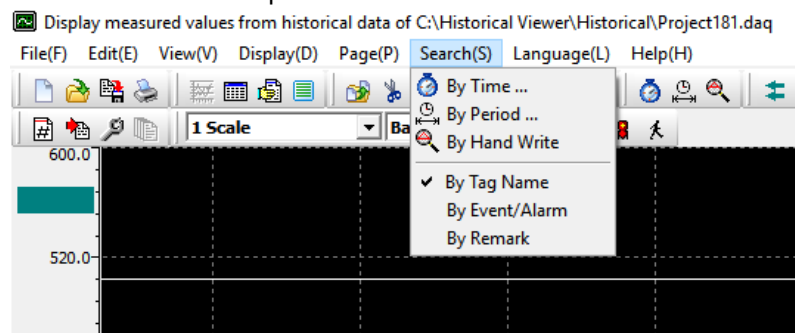

1. **By Time:** Search the data at a particular time.

2. **By Period:** Search the between two periods. Hold the mouse left key and move to select the period A and Period B.

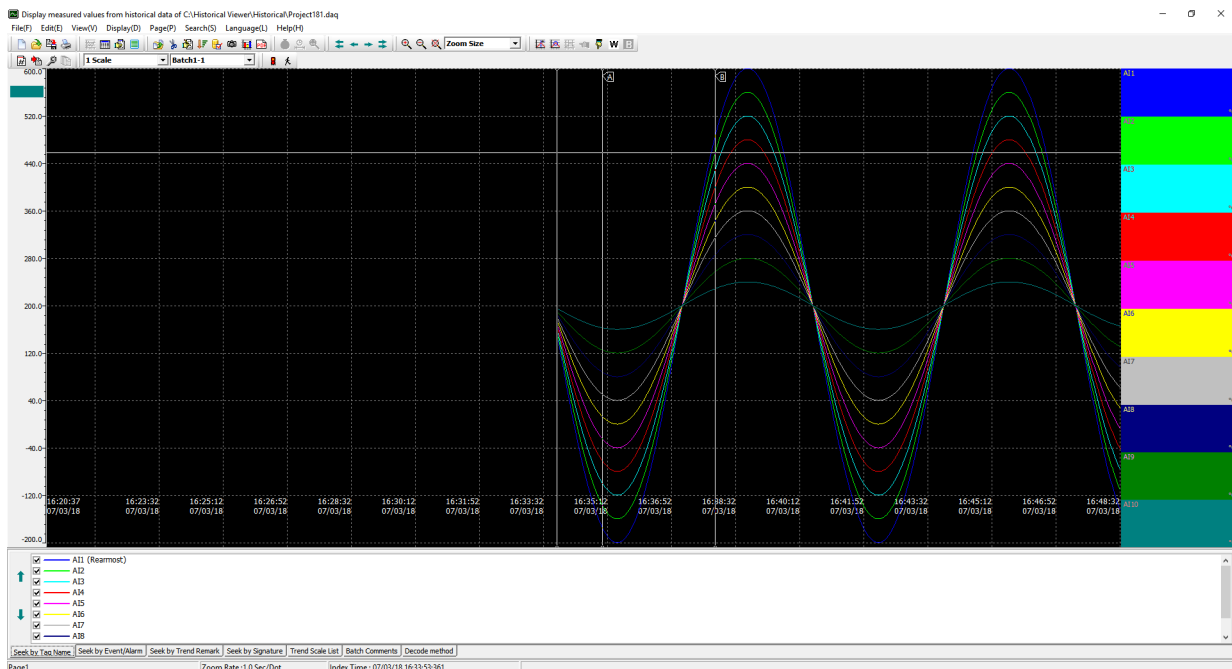
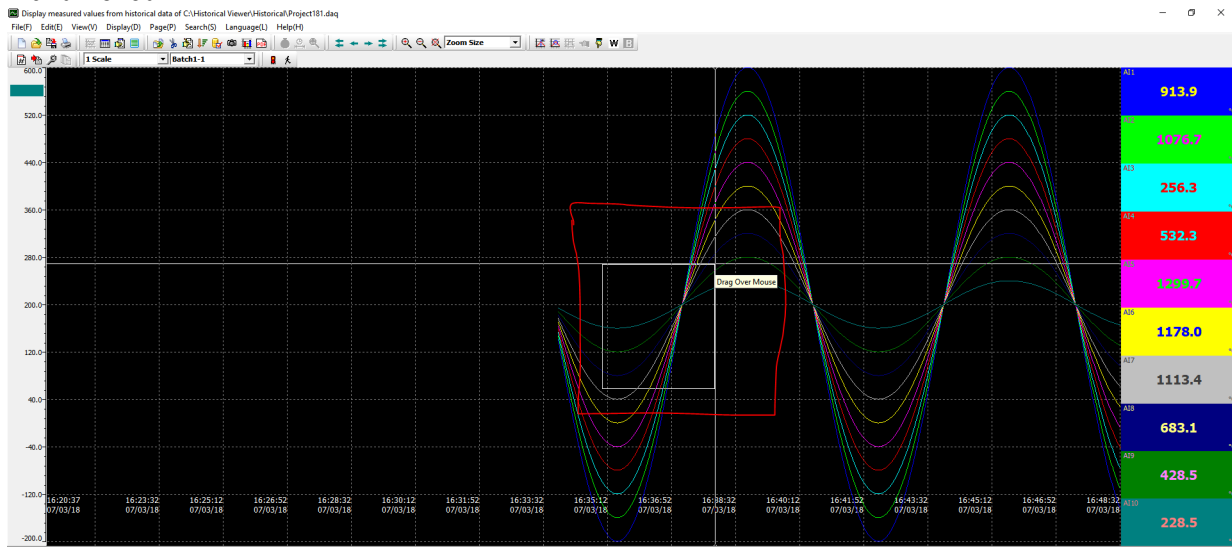

3. **By Handwrite:** Search the data by handwriting.
4. **By Tag Name:** Search the data by tag name.
5. **By Event/Alarm:** Search the data by Event or Alarm.
6. **By Remark:** Search the data by remark.

6.1.3.2.7 Language (L)

The display language of the software can be changed by selecting anyone of the available language from the sub menu.

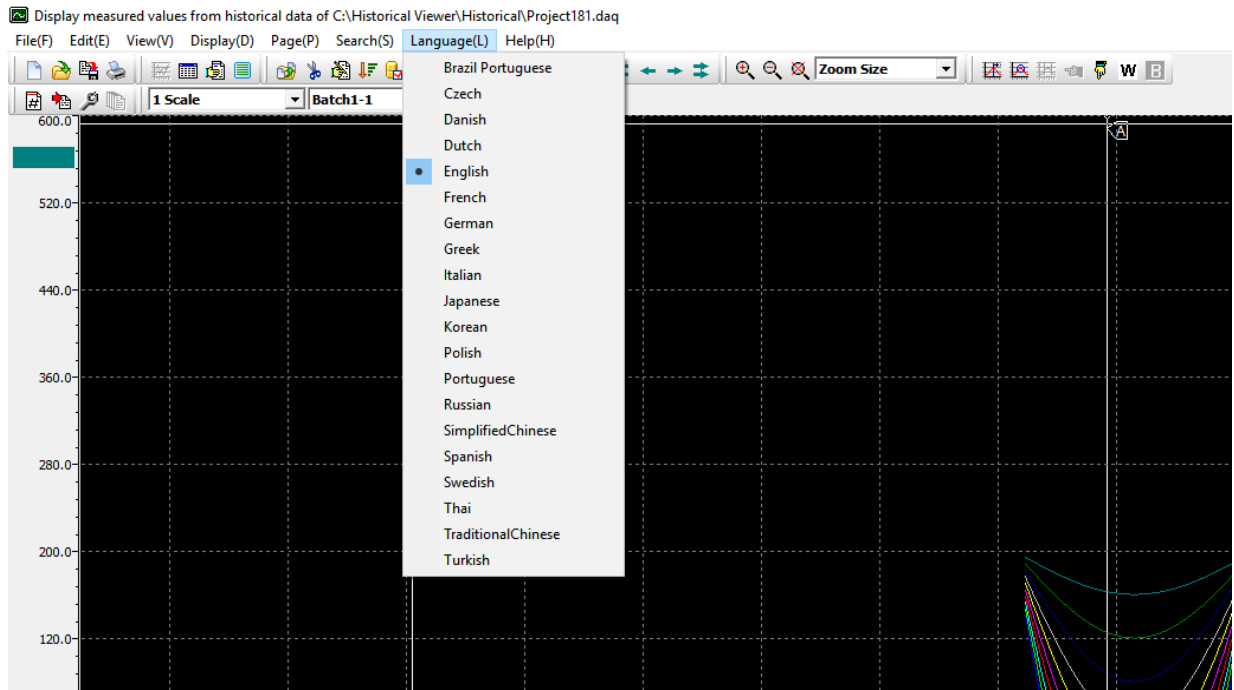

6.1.3.2.8 Help (H)



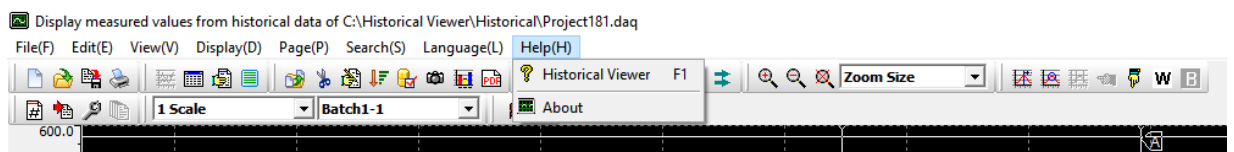







The help menu provide the information about the software and the necessary information.



1. **Historical Viewer:** Open the software help file.
2. **About:** Provides the information about the software like version and other related information.

6.1.3.3 Configuration Viewer-Tool Bar

The tool bar of configuration Viewer consists of the below tools.

- ✓  New
- ✓  Open
- ✓  Save
- ✓  Delete
- ✓  Bank
- ✓  Fast Backward
- ✓  Backward
- ✓  Forward
- ✓  Fast Forward
- ✓  Receive Configuration
- ✓  Send Configuration

6.1.3.4 Configuration Viewer-Menu Bar

The menu bar consists of 8 menus. They are listed as below.

1. File(F)
2. Edit(E)
3. Language(L)
4. Help(H)

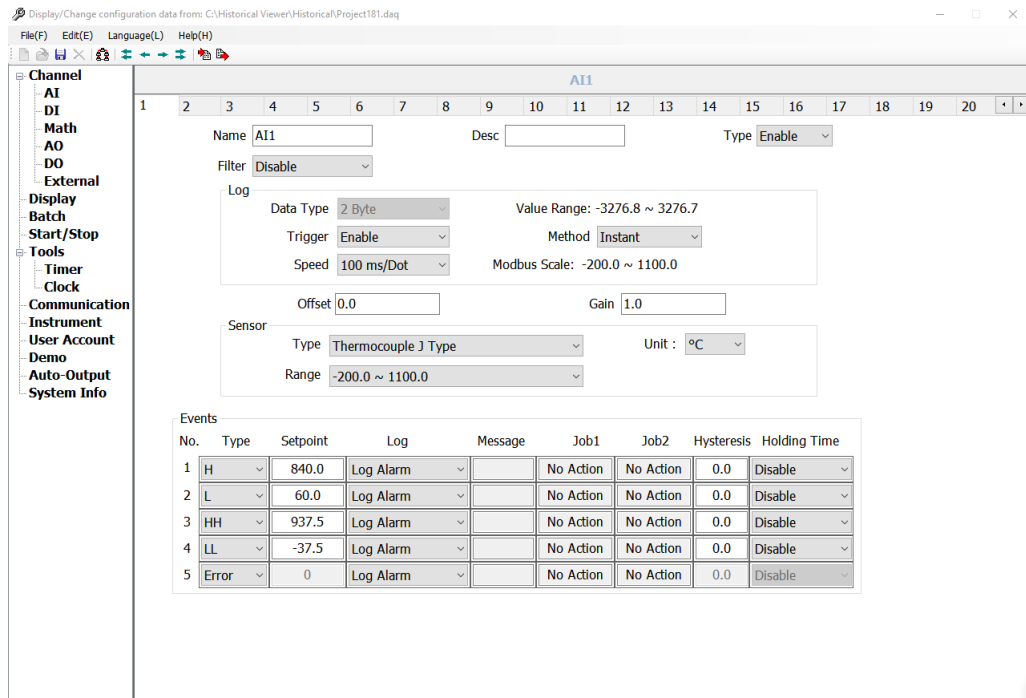

6.1.3.4.1 File (F)

The below are the sub menu options available in File Menu.

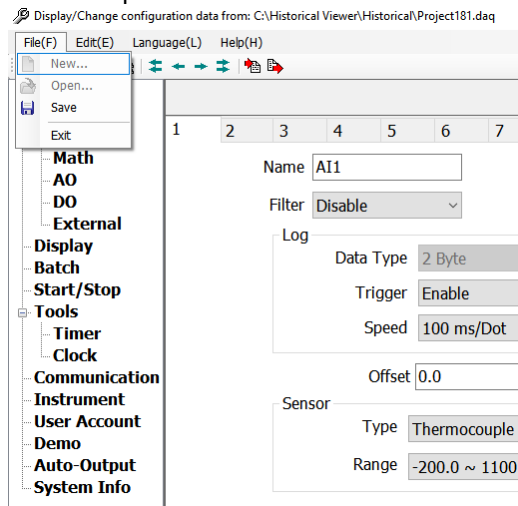

1. **Save:** Save the changed configuration.
2. **Exit:** Exit the program.

6.1.3.4.2 Edit (E)

The below are the sub menu options available in Edit Menu.

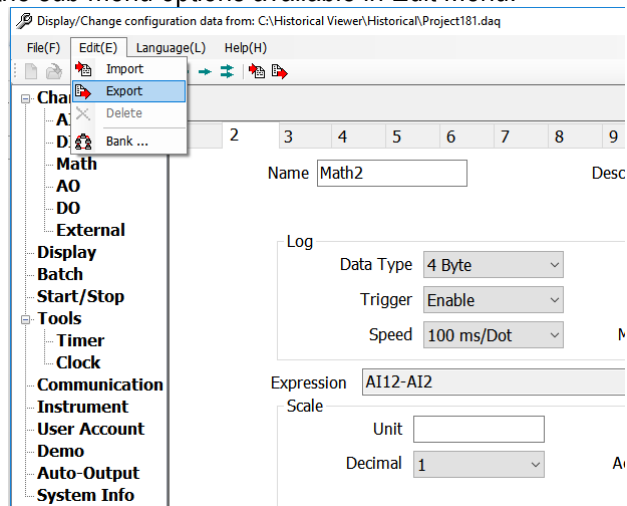

1. **Import:** Import the configuration from the device or storage media.
2. **Export:** Export the configuration to the device or storage media.
3. **Bank:** Change the connection properties for the project.

6.1.3.4.3 Language (L)

The display language of the software can be changed by selecting anyone of the available language from the sub menu.

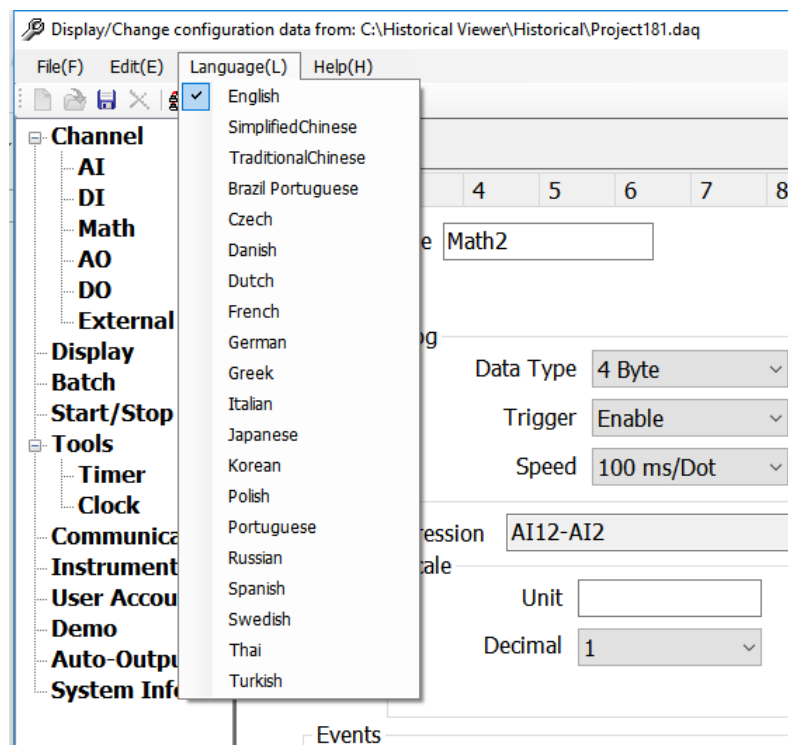

6.1.3.4.4 Help (H)

The help menu provide the information about the software and the necessary information.

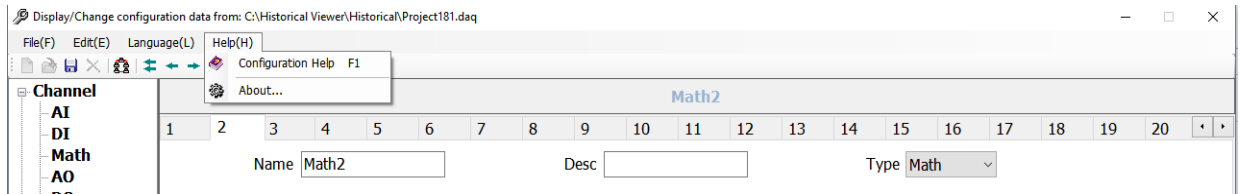

1. **Configuration Help:** Open the software help file.
2. **About:** Provides the information about the software like version and other related information.

6.1.3.5 Create a New Project

To Create a new project follow the below procedure.

1. Click the icon  or select New from File Menu.
2. The software will prompt the user to select the device type. Select Recorder (PR) and click OK to create a new project.

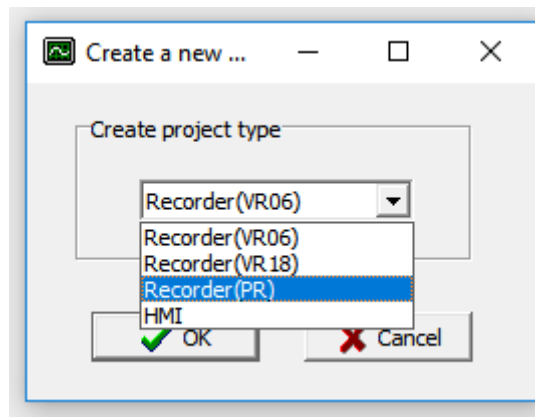

3. The Software will prompt the user to configure the project name and the path for the recorder.

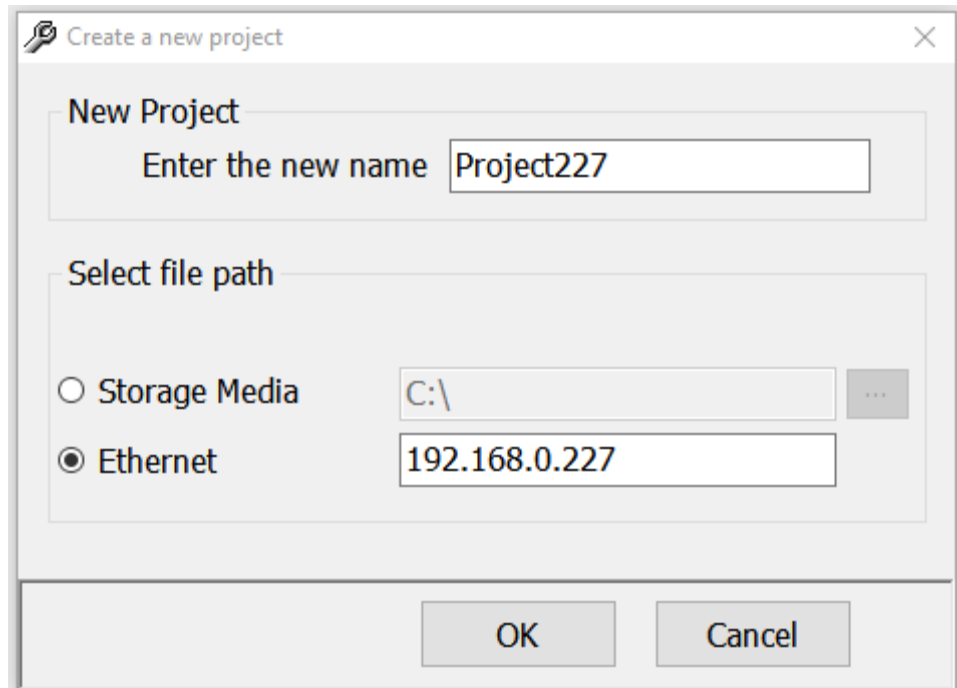

- ❖ Input the project name in the new project name field.
- ❖ If the device is connected to PC via Ethernet then select Ethernet in file path and

input the IP address of the recorder then press OK.

- ❖ If the historical data is dumped to SD Card or USB Disk then remove the SD card or USB disk from the recorder. Insert SD Card or USB disk to the PC then select Storage Media in file path and then select the path then press ok. The same procedure can be followed for the files copied from SD card USB disk on the PC by selecting the file path on the PC.
4. After the successful connection with the assigned path via Ethernet or Storage device the software will display the configuration of the device on the project via configuration viewer. If the security is set for CFR21 then the user login is required.

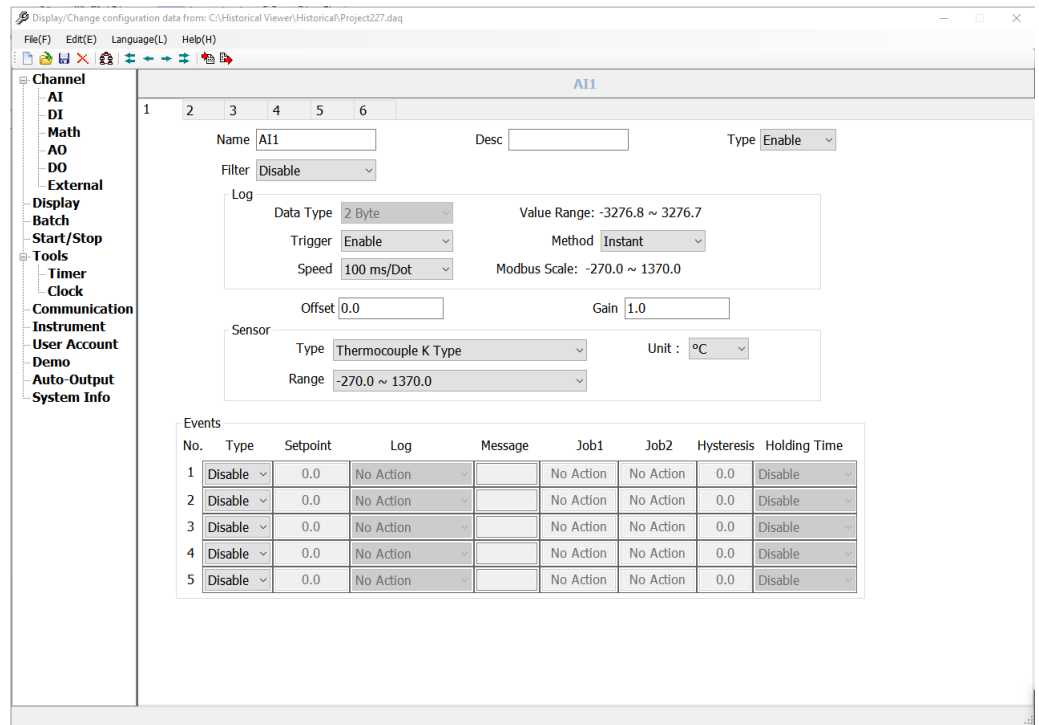

5. After receiving the configuration, close the configuration viewer to automatically import and view the historical trend of historical data. If the security is set for CFR21 then the user login is required.

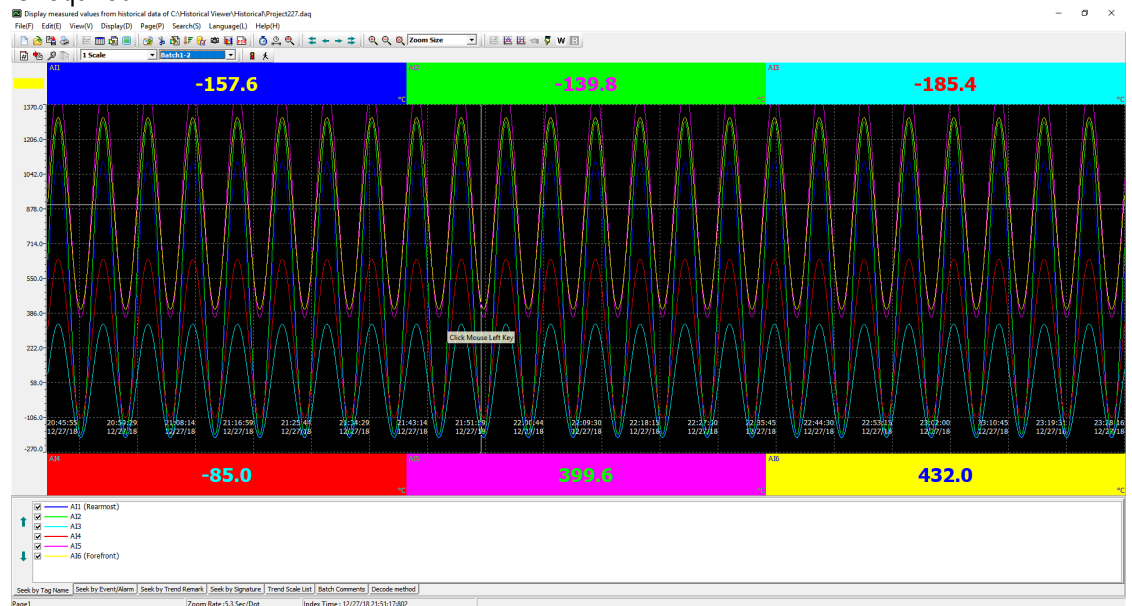

- If the data is import from storage media then the system will prompt the user to delete the data from storage media or not after import.

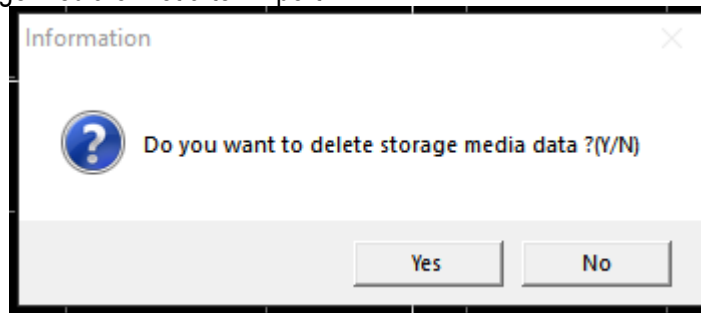

- If the security is configured as CFR21 then it is necessary to sign for imported data before close the project or logout.

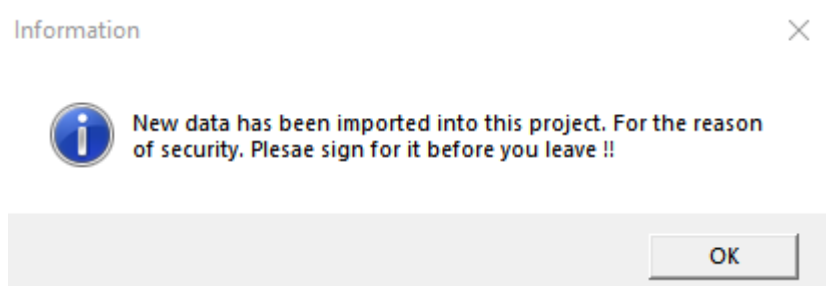

- If connection to the recorder fails then the software will show the error message.

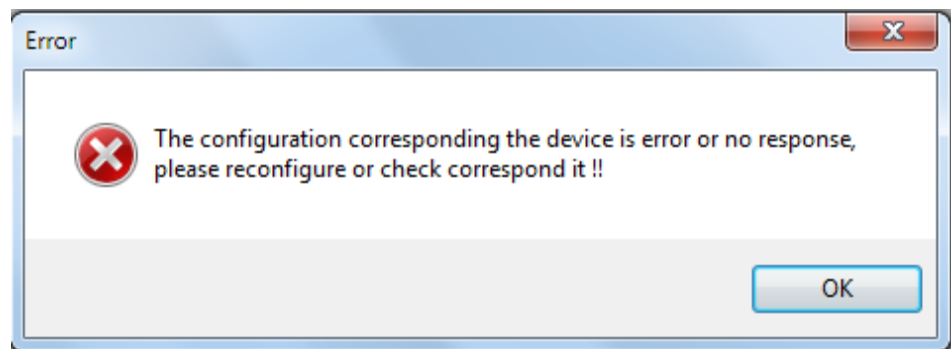

6.1.3.6 Open an Existing Project

To open and upload the new data to an existing project the following procedures to be followed.

- Click the icon  or select Open from File Menu.
- The software will list the projects from the default project path for the user to select.

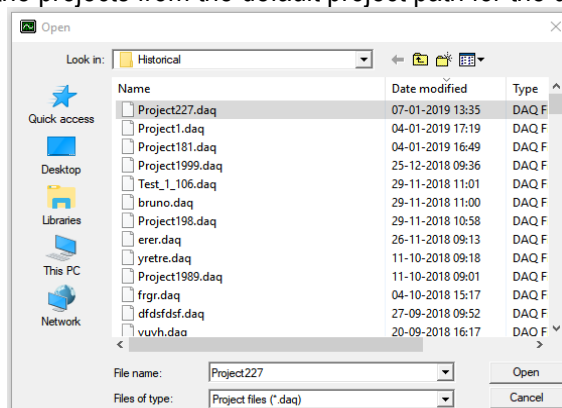

3. Select the project and click open to open the project.

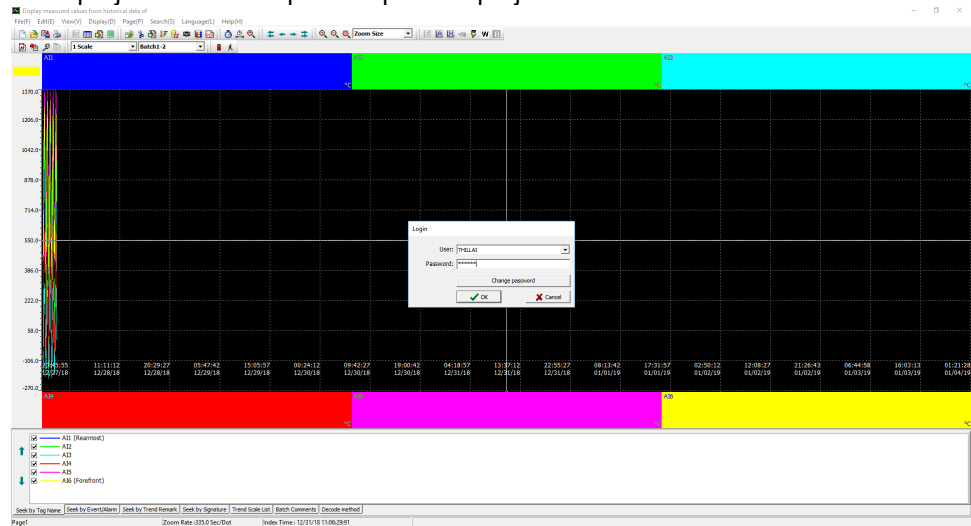

4. The existing data will be displayed along with the login option for CFR21 security.
5. Click  icon or select manually import from Edit menu to manually import the data from the device. The progress will be shown with a progress bar.

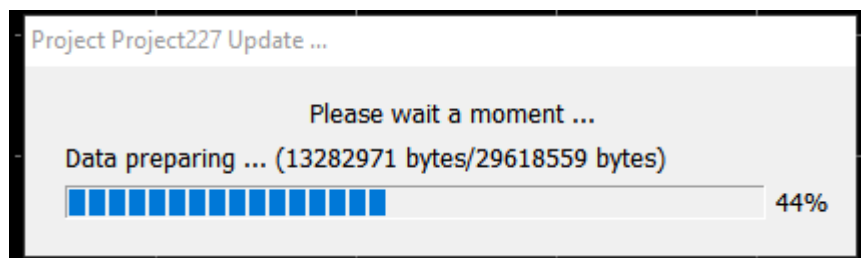

6. After successful import of the data the software will display the data.

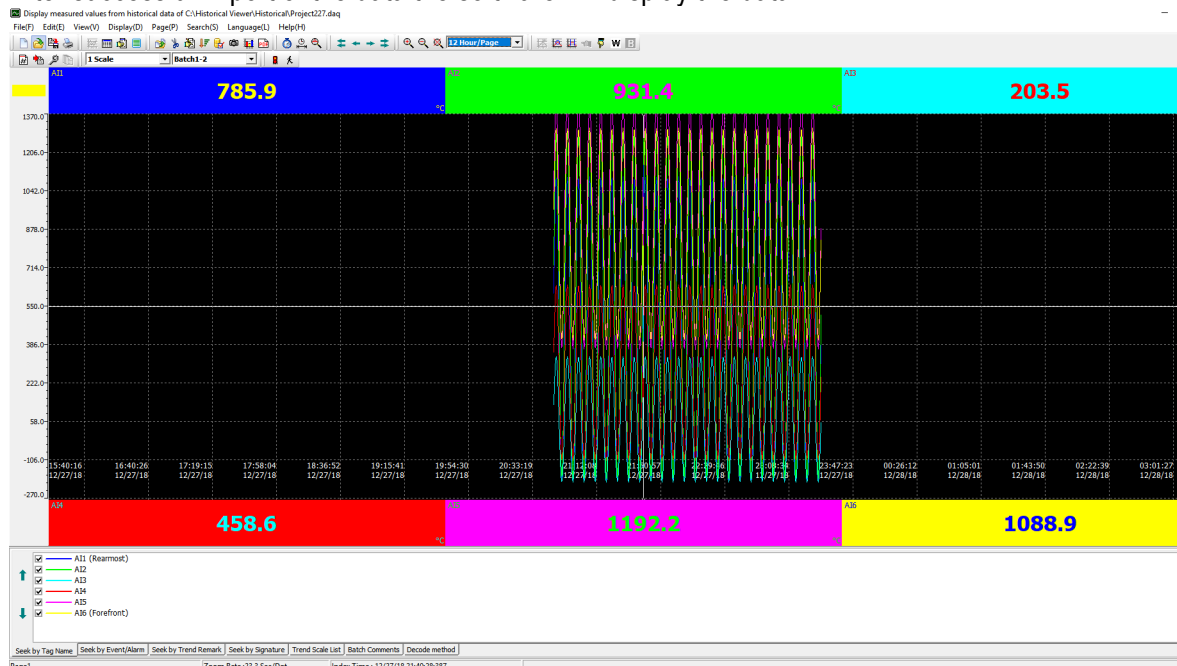

Note: The device configuration must be same as the existing project to upload new data to the project. Otherwise the software will show the warning message to create a new project.

6.1.3.7 Automatic Import of Data

The historical data can be imported automatically from the device in defined interval of time. The following steps to be followed for automatic import.

1. After creating a new project or opening an existing project select automatic import and export option from the Edit menu.
- 2.

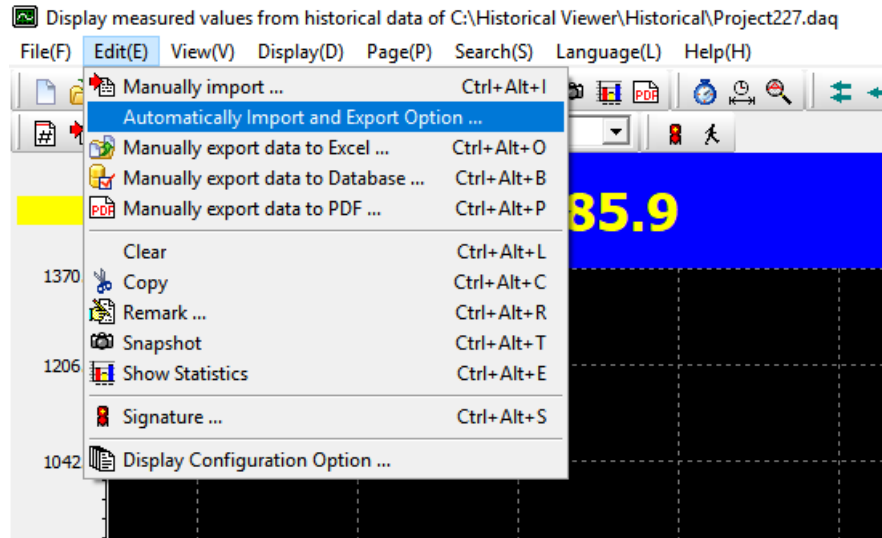

3. Select automatically, set the time interval, File path. The time interval can be set from 1 hour to 24 hours.

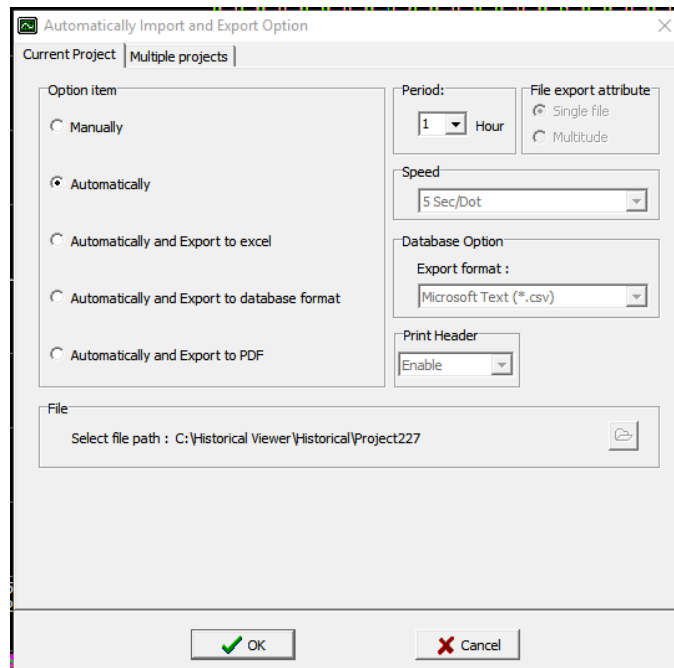

4. Now the software will automatically import the data from the device to the project.

6.1.3.8 Automatic Import and Export of Data

The historical data can be imported automatically and exported to Excel, PDF or Database format.

1. After creating a new project or opening an existing project select automatic import and export option from the Edit menu.

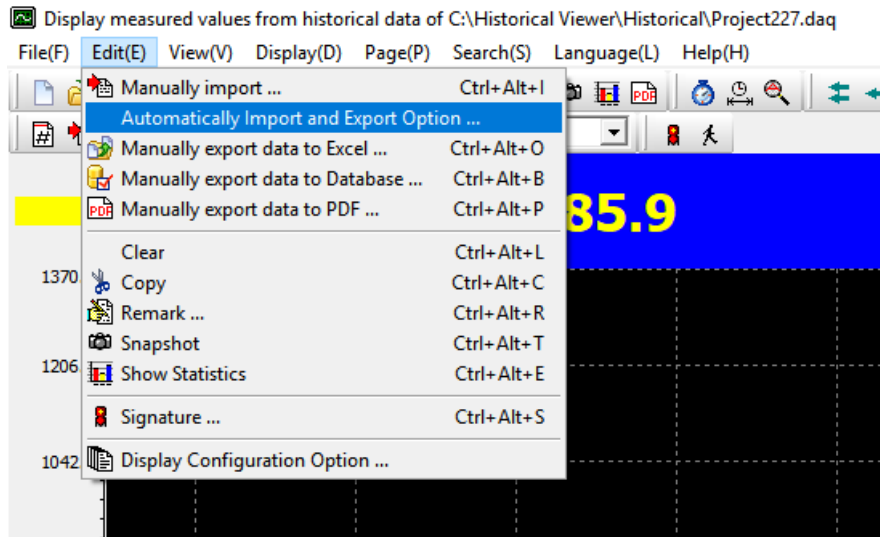

2. Select automatically and export to Excel or automatically and export to database format or automatically and export to PDF, set the time interval, File path and File attributes. The time interval can be set from 1 hour to 24 hours. The file attribute can be written to single file or multitude files.

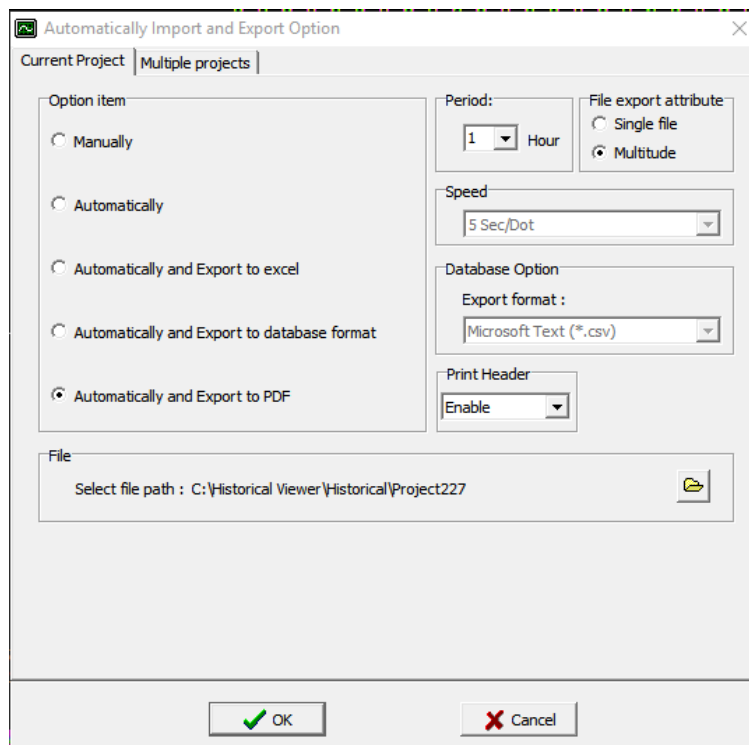

5. Now the software will automatically import the data from the device to the project and export to Excel or PDF or Database format.

6.1.3.9 Multiple Projects Automatic Import and Export of Data

The software supports the import of multiple projects automatically and exported to Excel, PDF or Database format. For doing multiple projects, import the following procedures need to be followed.

1. Create individual projects for individual recorders.
2. Set the export option in current project tab of Automatically Import and Export Option

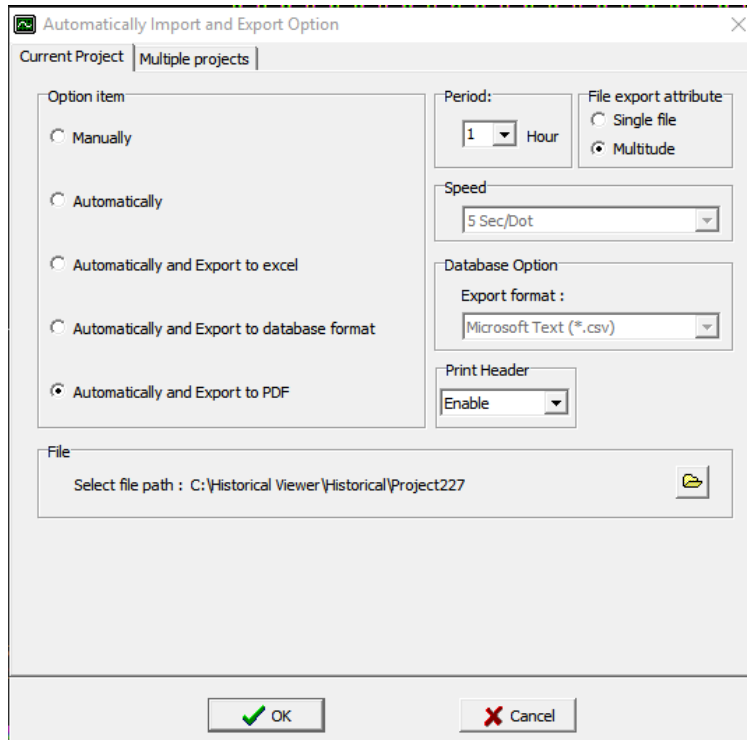

3. Select the project to be imported automatically in multiple project tab.

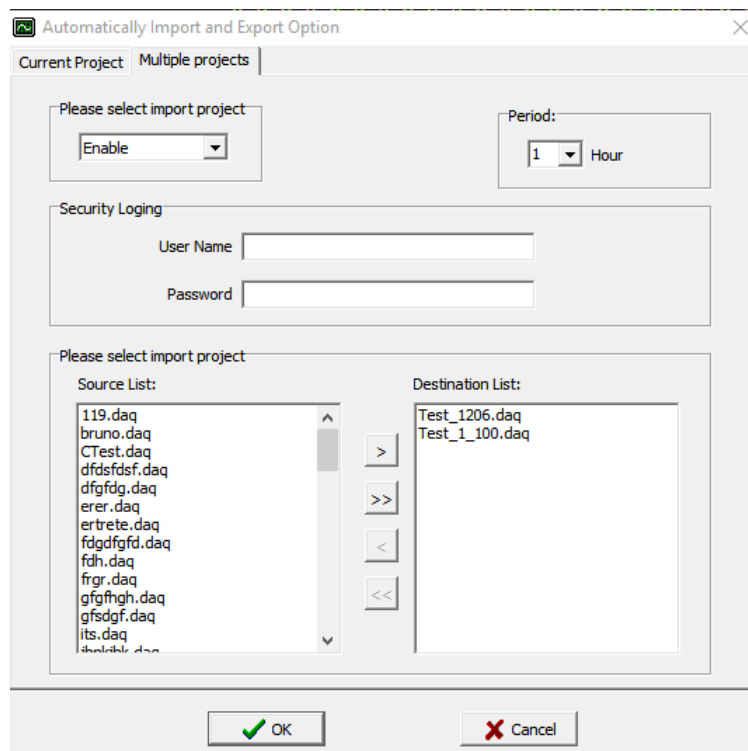

4. Set the login credentials and the import interval. The login credential must be same for all the projects.
5. Now the software will automatically import the data from the device to all the projects and export to Excel or PDF or Database format as per the selection.

6.2 Extensive Software

The extensive software Data Acquisition Studio (DAQ) consists of Real time Viewer, Configuration Viewer and Historical Viewer.

6.2.1 Data Acquisition Studio Software Installation

The Data Acquisition Studio installation will install Real time Viewer, Historical Viewer and Configuration Viewer on the PC.

6.2.1.1 System Requirements

Item	Minimum Requirements
System	IBM PC compatible computer with Intel Pentium IV or above
Operating System	Windows XP or above
Memory	1 GB
Hard Disk	50 GB Free Space on the hard disk
Communication Ports	RS232 or RS485 or Ethernet Port
Others	USB Port or SD Card Slot
Licence	USB Licence Key

6.2.1.2 Software Installation

The Data Acquisition Studio software can be installed by following the below procedure.

1. Download the Data Acquisition Studio software form the manufacturer's website.
2. Install latest dot Net software from Microsoft website
3. Install the software by double clicking the setupwizard.exe from Data Acquisition Studio folder.

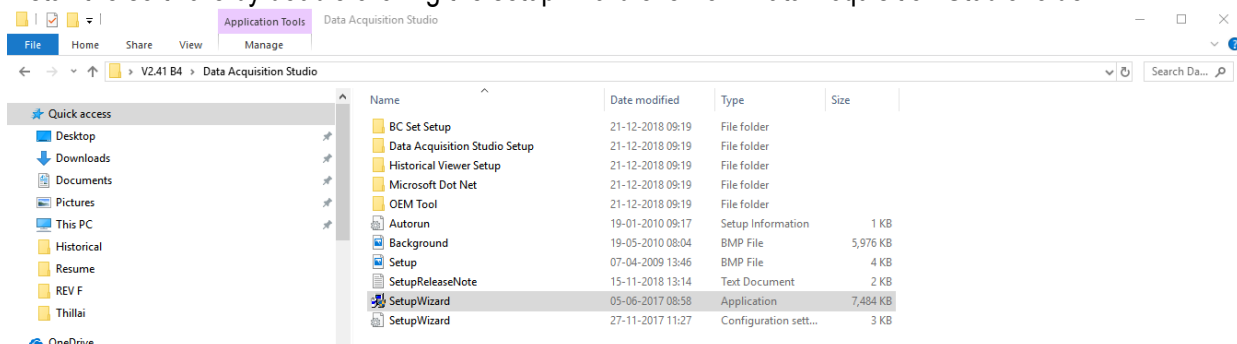

4. Select the language for installation.

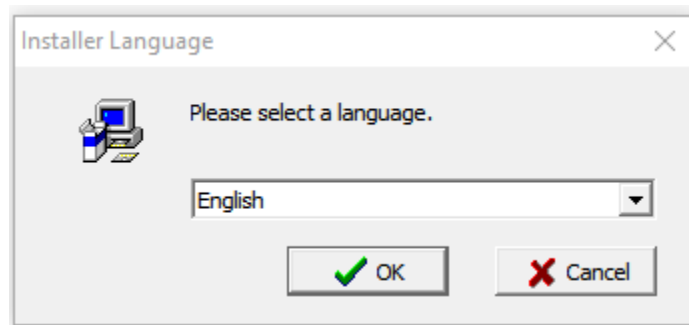

5. Select the software components to be installed and select install

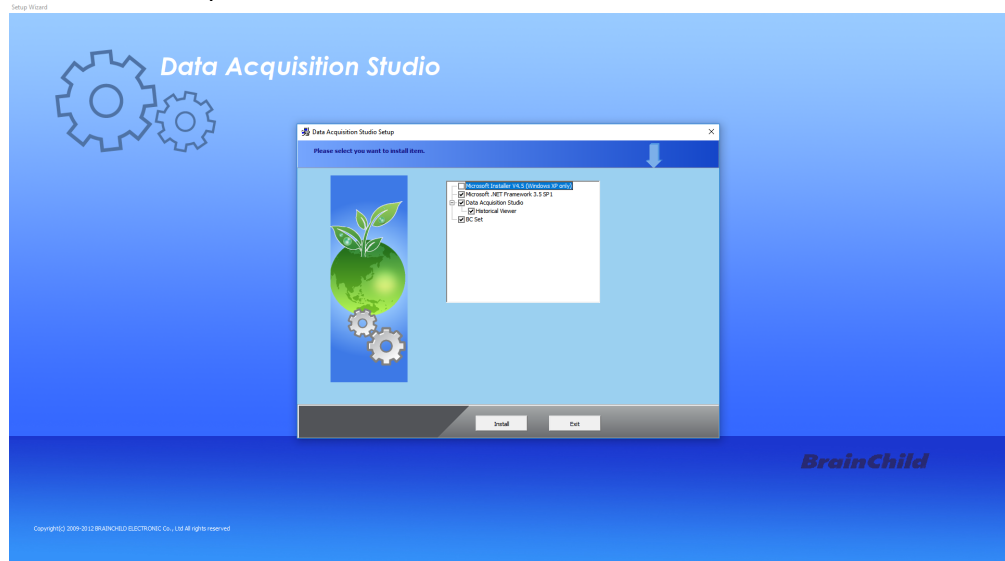

6. Follow on screen instructions to select the installation path and press next to continue the installation.

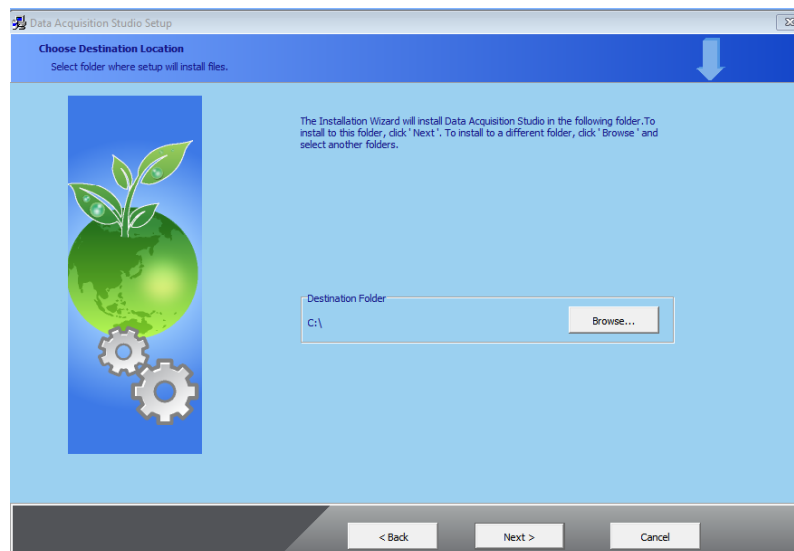

7. Follow onscreen instructions to complete the installation. Once the installation is completed the system will show the installation complete message.

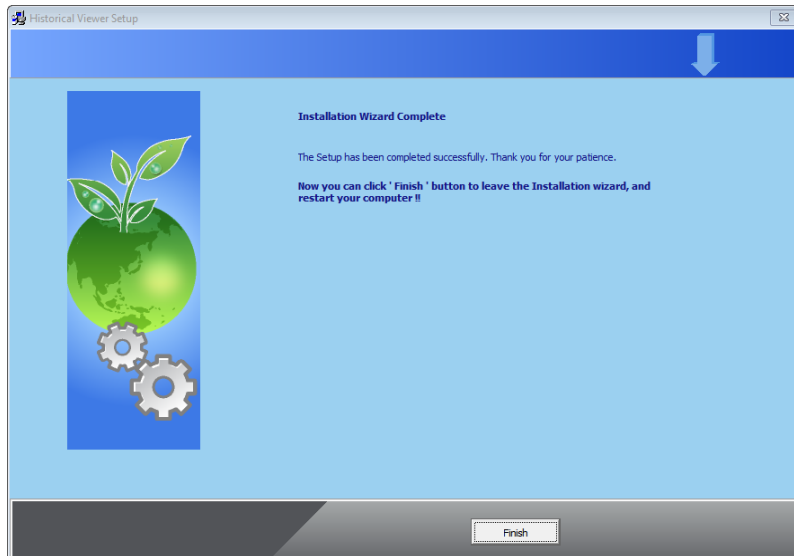

8. After installation is successful, shortcut for Real time Viewer and Historical viewer software will be created on the desktop.

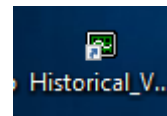
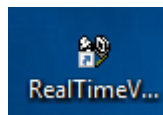

6.2.1.3 Uninstallation of Software

The software can be uninstalled by selecting the uninstall option on the control panel Add or Remove Programs.

6.2.2 Start and Exit

The Real time Viewer program can be start by using the shortcut  on the desktop or selecting the program Real time viewer from the start menu.

The program can be exit by simply closing the program X symbol on the top right corner of the screen.

6.2.3 Real Time Viewer





When running the program first time the initial screen displays like below.



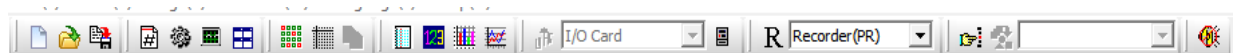













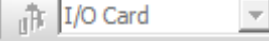

6.2.3.1 Real Time Viewer – Tool Bar

The real time viewer has the following tool bars.

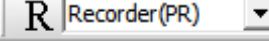

- ✓  New
- ✓  Open
- ✓  Save As
- ✓  Display Page Choice

- ✓  Configuration Data'
- ✓  Measured Data
- ✓  Arrange All (Mixed Mode)
- ✓  All Channel Digital
- ✓  Status
- ✓  Auto Page Mode
- ✓  Show Event/Alarm List
- ✓  Digital Mode Display
- ✓  Bar Graph
- ✓  Trend Mode
- ✓  I/O Card IO Module Configuration (only for IO Modules)
- ✓  Controller Configuration (only for Controllers)
- ✓  Recorder(PR) Recorder Configuration (only for recorders)
- ✓  Manually Operate Jobs
- ✓  Reset Counters of IO Module (only for IO modules)
- ✓  Mute Alarms

6.2.3.2 Real Time Viewer – Menu Bar

The menu bar of consists of 6 menus. They are listed as below.

1. File(F)
2. View(V)
3. Page(P)
4. Window(W)
5. Language(L)
6. Help(H)

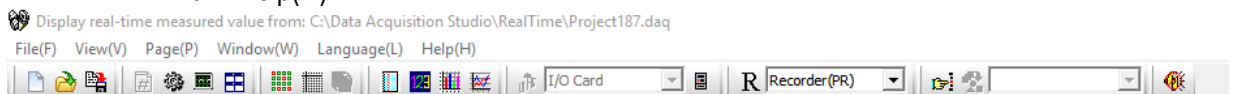

6.2.3.2.1 File (F)

The File menu consists of the below sub menu.

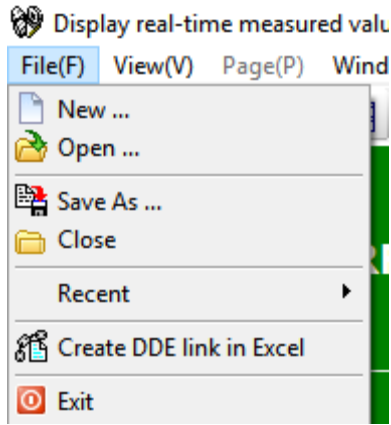

1. **New:** Create a new project.
2. **Open:** Open an existing project.
3. **Save As:** Save the project with a new name.
4. **Close:** Close the current project
5. **Recent:** Open recently opened projects.
6. **Create DDE link in Excel:** Create Dynamic Data Exchange in Excel for real time values.
7. **Exit:** Exit the program.

6.2.3.2.2 View (V)

The View menu consists of the below sub menu.

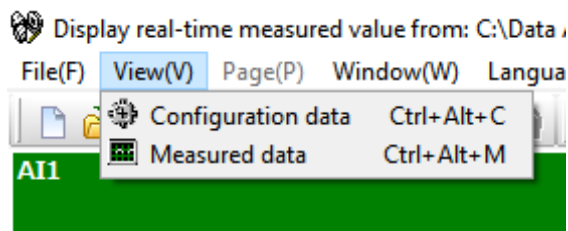

1. **Configuration Data:** Opens the configuration data of the project.
2. **Measured Data:** Opens the historical data of the project via Historical Viewer.

6.2.3.2.3 Page (P)

The Page menu consists of the available display pages to select. The user can select the display page to be viewed from the shown list.

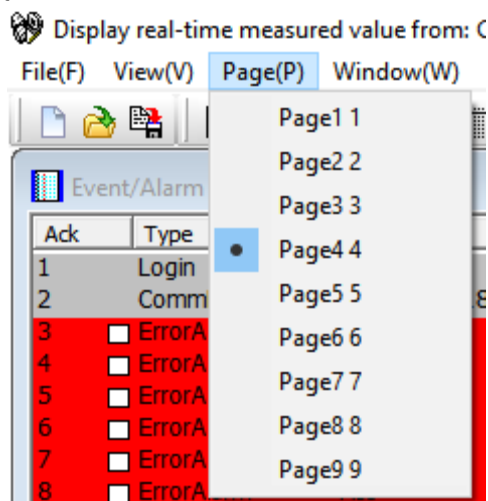

6.2.3.2.4 Window(W)

The Window menu consists of the different display modes to select. The user can select the display mode to be viewed from the shown list.

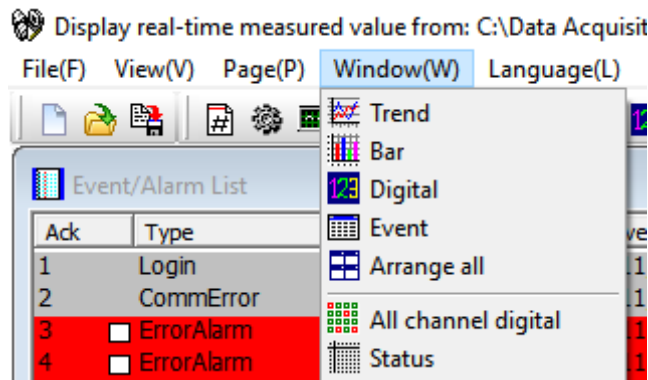

1. **Trend:** Shows the display page in trend mode.
2. **Bar:** Shows the display page in bar graph mode.
3. **Digital:** Shows the display page in digital display mode.
4. **Event:** Shows the Event/ Alarm List display.
5. **Arrange All:** Shows the display page with Trend, Bar Graph, Digital Display and Event/Alarm List.
6. **All Channel Digital:** Shows all the configured channels in digital mode as overview.
7. **Status:** Shows the status of counters and Totalizers.

6.2.3.2.5 Language (L)

The display language of the software can be changed by selecting anyone of the available language from the sub menu.

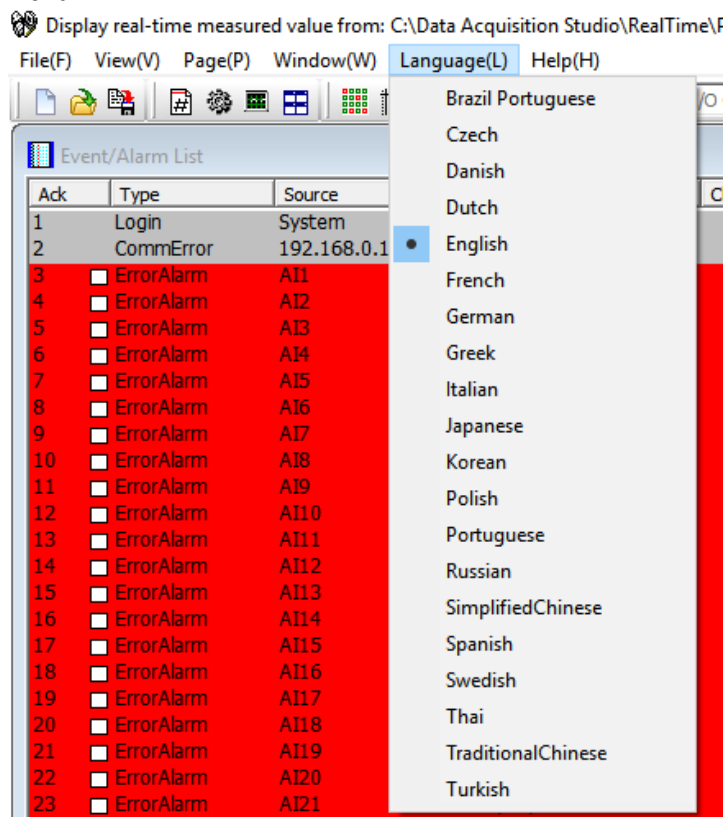

6.2.3.2.6 Help (H)

The help menu provide the information about the software and the necessary information.

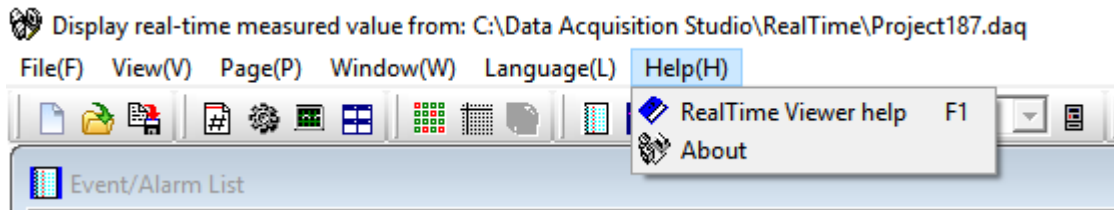

1. **Real-time Viewer:** Open the software help file.
2. **About:** Provides the information about the software like version and other related information.

6.2.3.3 Real-time Configuration Viewer-Tool Bar

The real time configuration has the following tools on the tool bar.

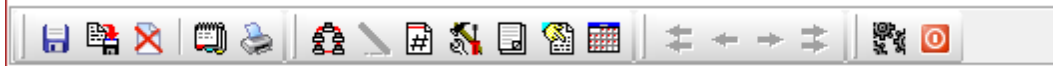

- ✓ Save
- ✓ Backup the configuration
- ✓ Delete the project
- ✓ Option
- ✓ Print
- ✓ Bank
- ✓ Channel Configuration
- ✓ Display Page Configuration
- ✓ Tools
- ✓ Comment
- ✓ Setup Controller (only for Controllers)
- ✓ Setup all Display pages in Digital Mode Overview display.
- ✓ Fast Backward
- ✓ Backward
- ✓ Forward
- ✓ Fast Forward
- ✓ Project Auto configure
- ✓ Close and return to main program.

6.2.3.3.1 Option

The Option menu of real time configuration has the following options.

1. Share
2. Email
3. Communication
4. Format
5. Display

6. Print auto-output
7. User Manage
8. The display of AI serial for IO Modules (only for IO Modules)
9. Auto start project

1. Share

The share menu will allow the user to configure for share or not to share the data with others.

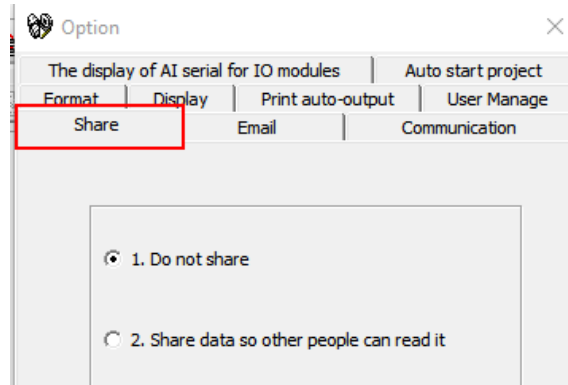

Share/do not share options are available for user selection. If share option is selected, then historical data available in the computer can be shared from other computers. On selection of this share data, shared folder will be created and following message will be shown



For example, the recorder is connected to PC with real time viewer and wish to analyse historical data at different computer. While opening project in the second computer, directly link to the project file available under **C:\Data Acquisition Studio** through network configuration. This will minimize the data transfer between Modbus slaves and the computers and make it more efficient by using available resources through network Configurations.

2. Email

The Email menu will allow the user to configure the email server to send email on an event or alarm. The default Port number 25 is used to send email from SMTP server. If network administrator configured different port in LAN for accessing internet/email, then the user has to modify the port number accordingly.

To send an email for any event, the procedure is as follows.

- ❖ Set SMTP server details as below. Please contact system or network administrator for the server details if the computer is connected in LAN.
- ❖ Host, Port, User name,
- ❖ From: Sender email address
- ❖ To: Receiver email address (Max.10 email addresses can be selected)

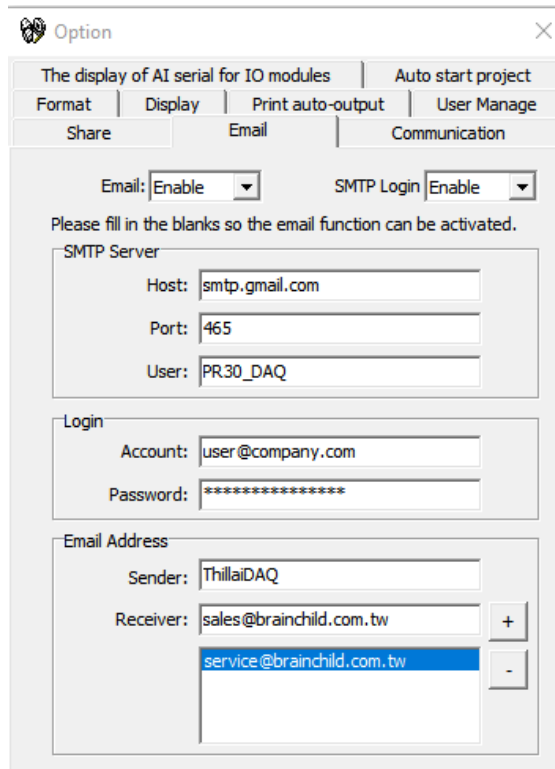

- ❖ In case, email is successful, it delivers as follows
 - Type: HI Alarm
 - Source: Tag1
 - Active Time: 05/08/09, 13:31:04
 - Value: 50
 - Comment: Level high
- ❖ If Email is failed to deliver, then it prompts the following error message. In this case, it requires to check all the email settings



3. Communication

The communication menu will allow the user to configure the communication parameters for the project.

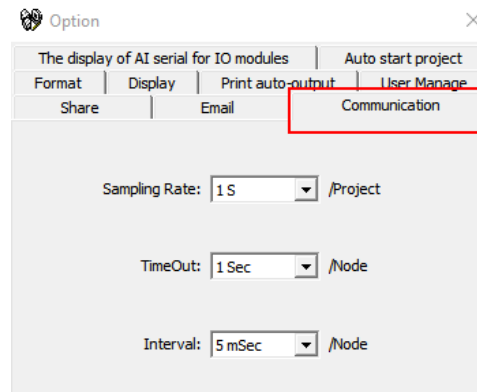

Sampling rate: It is used to set data display time for Real-Time Viewer. User can select one from the following for real time monitoring.

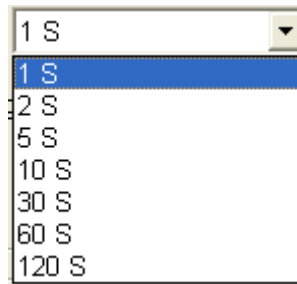

Time out: This is time set for generating time out errors related to real time viewer Communication.

For example, if Recorder and PC with data acquisition software are located at different places connected through Ethernet across different gateways, and then user can adjust sampling rate and time out settings to avoid errors in communication. When real time Viewer is running, please observe the following taskbar at the bottom side of the screen.



Here, scan time should always be less than sampling rate. Otherwise, communication errors will occur. If PC and Modbus slave devices are connected by long distance network, then there might be chances that scan time gets increased. So check this and set sampling-rate more than scan time. Also user can set time out settings to generate communication failure errors. Maximum time out settings possible is 60 sec. For example, scan time is adjusted and time out setting = 30 sec. This means, if scan time is more than sampling rate for more than 30 sec, then communication errors will be generated.

4. Format

The Format menu will allow the user to configure the date time format and set the name for the software on the PC.

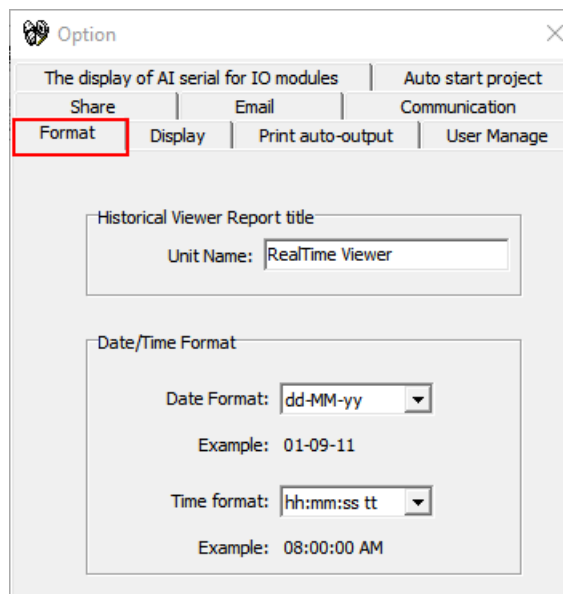

5. Display

The Display menu will allow the user to configure the display properties for communication error, latest event/alarm list, auto page scrolling and screen display for alarm action.

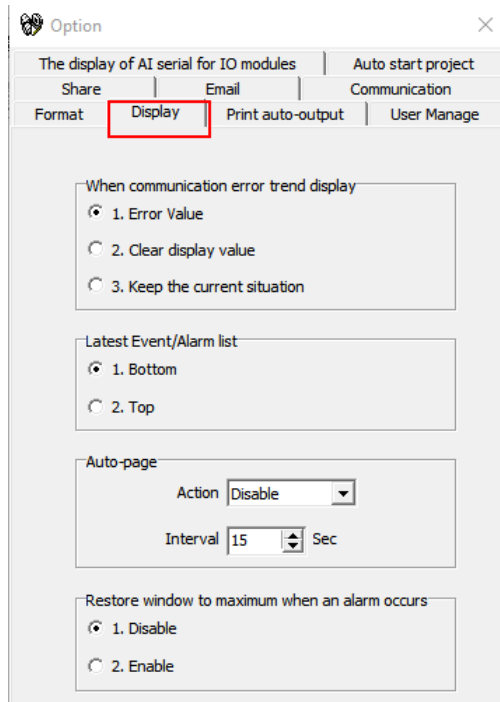

Auto-page:

The Auto page function is to rotate pages at set time interval. If this option is enabled and time is set, then, display pages in Real Time Viewer will be rotated cyclically as per set time

Action: Enable, Disable options are available

Interval: This is time interval and max. 60 sec. is possible

6. Print Auto-output

The Print auto-output menu will allow the user to configure to do the automatic printing of historical data from the PC in pre-defined interval.

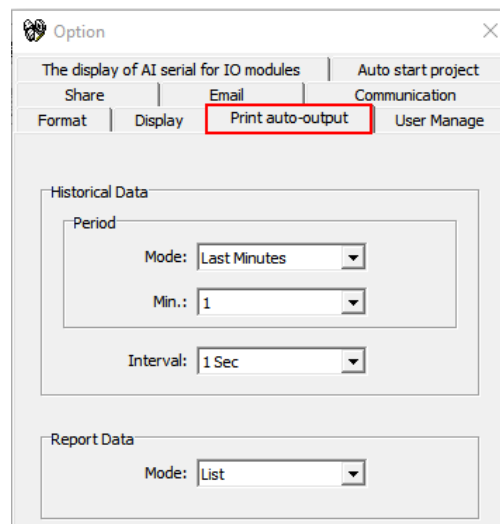

7. User Manage

The User Manage menu will allow the user to configure the user security for the project. The user can set the password and auto logout time.

Disable: The security function will be disabled.

Set Password: Set password only for the user security.

User Security Level: The user can set password and auto logout time for security.

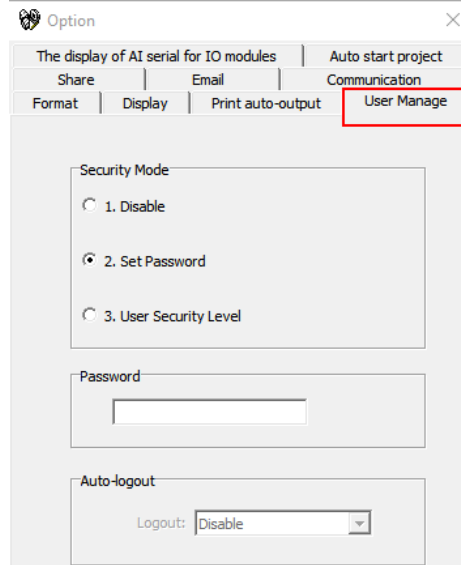

8. The display of AI serial for IO modules

This is applicable only for IO module. If the IO module is connected with real time viewer then this option will allow the software check the input status of the IO module and display according to the selection in this tab.

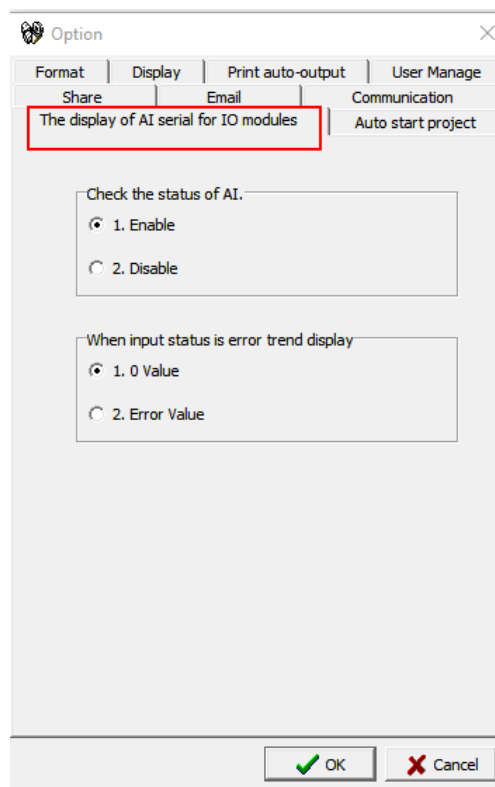

9. Auto start project

This tab will allow the user to configure the last project to be started when the software started.

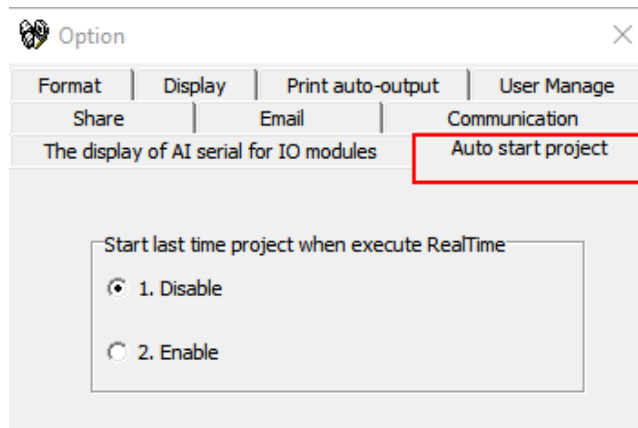

6.2.3.3.2 Bank Configuration

There are four banks are available in real time viewer configuration to configure for the devices to connect with the software. All the four banks will utilize different communication ports for the communication. The Ethernet and serial communication ports can be used for communication.

1. Ethernet Bank Configuration

The Ethernet port can be configured with port no as 502 and protocol as Modbus_TCP

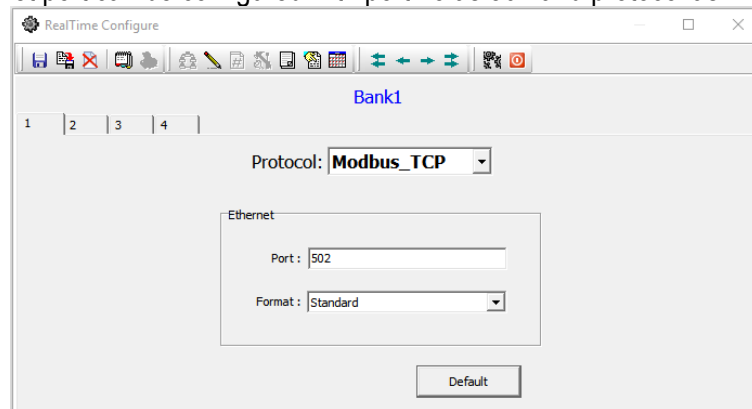

1. RS232/RS485 Bank Configuration

The serial RS232 or RS485 ports can be configured with Protocol as Modbus_RS232 and other communication parameters such as com port no, Baud Rate, Parity, Data Bits and Stop Bits as per the connection.

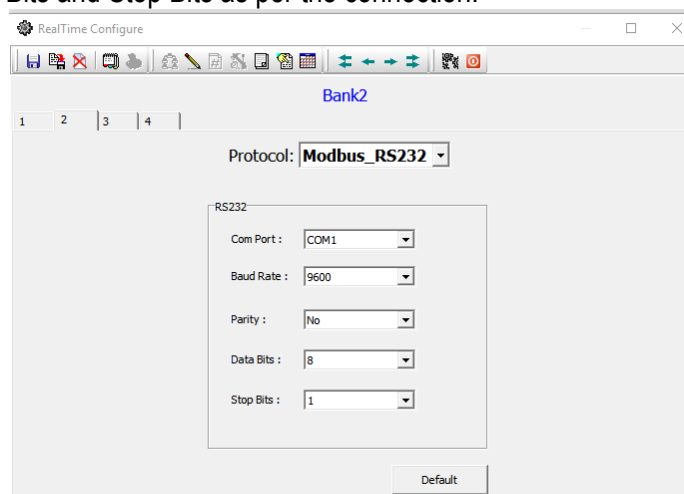

Note: It is possible to connect more than one device with the software with different mode of connection. For example one device can be connected via Ethernet and another device can be connected via RS485 or RS232.

6.2.3.3.3 Channel Configuration

The channels are auto configured with all the configured tags from the recorder by the software. The configured tags channels can be viewed by selecting the channel configuration icon  in real-time configuration. It will display the configured device and channel information.

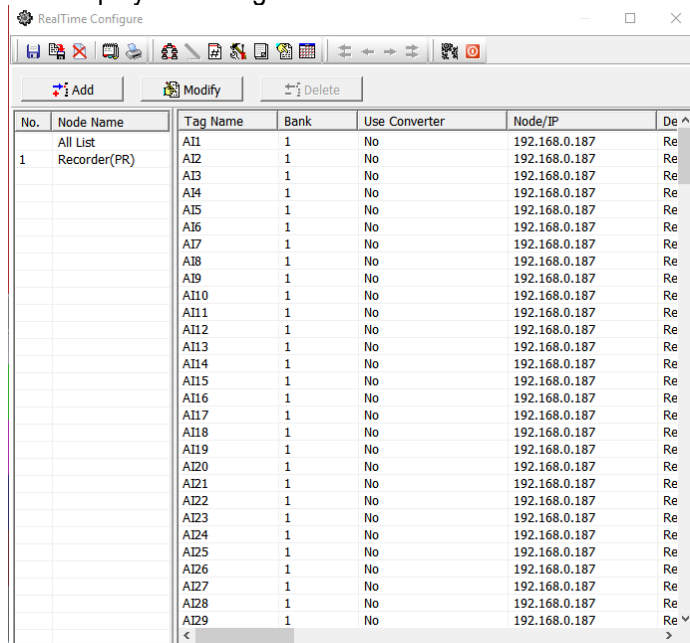

No.	Node Name	Tag Name	Bank	Use Converter	Node/IP	De
1	All List	AI1	1	No	192.168.0.187	Re
	Recorder(FR)	AI2	1	No	192.168.0.187	Re
		AI3	1	No	192.168.0.187	Re
		AI4	1	No	192.168.0.187	Re
		AI5	1	No	192.168.0.187	Re
		AI6	1	No	192.168.0.187	Re
		AI7	1	No	192.168.0.187	Re
		AI8	1	No	192.168.0.187	Re
		AI9	1	No	192.168.0.187	Re
		AI10	1	No	192.168.0.187	Re
		AI11	1	No	192.168.0.187	Re
		AI12	1	No	192.168.0.187	Re
		AI13	1	No	192.168.0.187	Re
		AI14	1	No	192.168.0.187	Re
		AI15	1	No	192.168.0.187	Re
		AI16	1	No	192.168.0.187	Re
		AI17	1	No	192.168.0.187	Re
		AI18	1	No	192.168.0.187	Re
		AI19	1	No	192.168.0.187	Re
		AI20	1	No	192.168.0.187	Re
		AI21	1	No	192.168.0.187	Re
		AI22	1	No	192.168.0.187	Re
		AI23	1	No	192.168.0.187	Re
		AI24	1	No	192.168.0.187	Re
		AI25	1	No	192.168.0.187	Re
		AI26	1	No	192.168.0.187	Re
		AI27	1	No	192.168.0.187	Re
		AI28	1	No	192.168.0.187	Re
		AI29	1	No	192.168.0.187	Re

The channel configuration can be modified or deleted by selecting Modify or Delete options. There are additional channels can be added by selecting Add option in the software. The available channels are as below.

1. Recorder Channels from Recorder
2. Controller Channels from Controller
3. IO Module Channel from IO Modules
4. Math channels for Math operation

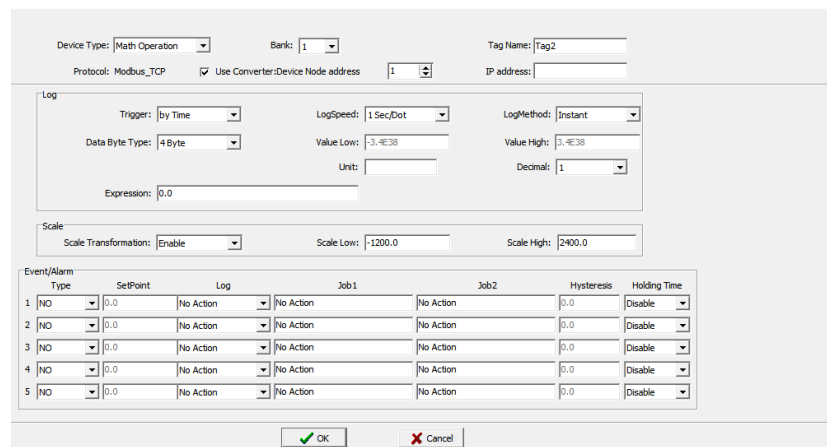

Device Type: Math Operation Bank: 1 Tag Name: Tag2

Protocol: Modbus_TCP Use Converter: Device Node address 1 IP address:

Log

Trigger: By Time LogSpeed: 1 Sec/Dot LogMethod: Instant

Data Byte Type: 4 Byte Value Low: -3.4E+38 Value High: 3.4E+38

Expression: 0.0 Unit: Decimal: 1

Scale

Scale Transformations: Enable Scale Low: -1200.0 Scale High: 2400.0

Event/Alarm Type	SetPoint	Log	Job1	Job2	Hysteresis	Holding Time
1 NO	0.0	No Action	No Action	No Action	0.0	Disable
2 NO	0.0	No Action	No Action	No Action	0.0	Disable
3 NO	0.0	No Action	No Action	No Action	0.0	Disable
4 NO	0.0	No Action	No Action	No Action	0.0	Disable
5 NO	0.0	No Action	No Action	No Action	0.0	Disable

OK Cancel

5. Linear Channels for 3rd party Modbus slave devices to connect via Modbus protocol.

Device Type: Linear Bank: 1 Tag Name: Tag3
 Protocol: Modbus_TCP Use Converter:Device Node address 1 IP address:

Log
 Trigger: by Time LogSpeed: 1 Sec/Dot LogMethod: Instant
 Data Byte Type: 4 Byte Value Low: -3.4E38 Value High: 3.4E38
 Gain: 1.0 Offset: 0.0 Decimal: 1

Device
 Register Type: Input Register (3000x) Data Type: IUINT16 Starting Address: 0
 Unit: Inverse: Disable

Conversions
 Type: Enable Engineering Low: -1999.9 Engineering High: 4553.6
 RAW Low: 0 RAW High: 65535

Event/Alarm	Type	SetPoint	Log	Job 1	Job 2	Hysteresis	Holding Time
1	NO	0.0	No Action	No Action	No Action	0.0	
2	NO	0.0	No Action	No Action	No Action	0.0	
3	NO	0.0	No Action	No Action	No Action	0.0	
4	NO	0.0	No Action	No Action	No Action	0.0	
5	NO	0.0	No Action	No Action	No Action	0.0	

OK Cancel

6. Simulate Channels to simulate the input signals by the software

Device Type: Simulate Bank: 1 Tag Name: Tag3
 Protocol: Modbus_TCP Use Converter:Device Node address 1 IP address:

Log
 Trigger: by Time LogSpeed: 1 Sec/Dot LogMethod: Instant
 Data Byte Type: 4 Byte Value Low: -3.4E38 Value High: 3.4E38
 Gain: 1.0 Offset: 0.0 Decimal: 1

Simulation
 Wave Type: Sine WaveCycle/Sec: 400 Wave Amplitude: 1120
 Wave Offset: 440

Scale
 Scale Transformation: Disable Scale Low: -120.0 Scale High: 1000.0

Event/Alarm	Type	SetPoint	Log	Job 1	Job 2	Hysteresis	Holding Time
1	H	776.0	No Action	No Action	No Action	0.0	Disable
2	L	104.0	No Action	No Action	No Action	0.0	Disable
3	HH	860.0	No Action	No Action	No Action	0.0	Disable
4	LL	20.0	No Action	No Action	No Action	0.0	Disable
5	Error		No Action	No Action	No Action	0.0	Disable

OK Cancel

All the channel configurations are similar to recorder channel configuration. Every channel can be configured with 5 different types of events or alarms similar to recorder and each event can be configured with two jobs.

Device Type: Display channel source

Bank: Display current Bank number

Tag Name: It is to define the name for each channel in maximum 9 characters

Auto-Update: If you wish to modify Tag name and modify configuration, deselect it

Use Gateway-Device Node address: It is address of selected device type

IP address: Display current gateway IP address

Log Type: Enable/Disable. Select disable while a specific channel is not required at this time. Select enable while a specific channel is required

Log Speed: It is the logging speed (recording speed) of measured data. Select LogSpeed column, then choose 1, 2, 5, 10, 15, 20, 30 seconds, 1, 2, 5, 10, 15 Minutes, 1 Hour, 2 Hour.

Log Method: The method of logging measured data. Select the column, and then choose the Log method of Instant, Average, Minimum or Maximum data

Instant: logging in the last measured data at the sampling interval

Average: logging in averaged measured data at the sampling interval

Minimum: logging in minimum measured data at the sampling interval
Maximum: logging in maximum measured data at the sampling interval
Trigger: Select various types like “by time” or “by change” or disable
By Time: Data log based on Log Speed and Log Method
By Change: Depends on Tolerance setting. Log speed and Log Method is disabled if this option is selected and if this option is selected sampling rate is fixed at 1 sec. This option is selected to save memory in PC. If data logging is required in set log speed (fixed time interval), select Trigger as by timer. If data logging is required only when there is change in process value, then select Trigger as by change. This will save memory
Tolerance: This is enabled if “by change” is selected at Trigger Type. For ex: If tolerance is set at 0.5, then if the new process value is more than or less than 0.5, then only the new sample will be logged
Data Byte Type: Choose 2 or 4 or 8 byte
Range Low: Range low for specific channel in selected device, ex: 4.00 mA
Range High: Range high for specific channel in selected device, Ex: 20.00 mA
Decimal: Select one of the options - 0, 1, 2, 3 or 4
Gain: It is a multiplier to correct the sensor error. The correct value = (the process value + offset) x gain
Offset: It is offset value to correct the sensor error
Unit: The engineering unit of input
Sensor: It displays input type automatically as per the type of IO card selected
Scale Low: Defines the low scale with decimal if necessary. For instance, input 0-10 V, the Scale Low can be set up with value 0.00 to be correspondent to low range 0 V.
Scale High: Defines the high scale with decimal if necessary. For instance input 0-10 V, the Scale High can be set up with value 100.00 to be correspondent to high range 10 V.

6.2.3.3.4 Event

The Event is frequently used for Alarm purpose. Event can also be used for digital output: DO, Timer, Totalizer, Counter or Report.

Type: There are various types of H, L, HH, LL, R, r or Error to be selected for job or Alarm purpose.

H: High limit. When the process is over high limit, the alarm or job is actuated.

L: Low limit. Any the process is lower than low limit, the alarm or job is actuated

HH: High high limit, to set up another limit higher than high limit for double warning.

LL: Low low limit, to set up another limit lower than low limit for double warning.

R: Increasing rate of change. The job or alarm is actuated when the rate of increasing process value is greater than the specified rate time interval. For example, when the Setpoint is set to 100_1S, if the process is increasing greater than the value 100 in 1 second, then job or alarm will be actuated.

r: Decreasing rate of change. The job or alarm is actuated when the rate of decreasing process value is greater than the specified rate time interval. For example, when the Setpoint is set to 50_2S if the process is decreasing greater than the value 50 in 2 seconds, then job or alarm is actuated.

Dev+: It is deviation + event. This event will be triggered on the positive deviation of process value. The job or alarm is activated when the process value is deviated by the value higher than set point from the previous process value.

For example,

Set point = 10

At 10.00.01 Hrs, Tag1 = 40

At 10.00.02 Hrs, Tag1 = 51

Then, job or alarm is activated

Dev-: It is deviation - event. This event will be triggered on the negative deviation of process value. The job or alarm is activated when the process value is deviated by the value lower than set point from the previous process value.

For example,

Set point = 10

At 10.00.01 Hrs, Tag1 = 40

At 10.00.02 Hrs, Tag1 = 29

Then, job or alarm is activated.

Error: If there is error in channel input, then alarm or job is actuated

Set point: To set up the process value for actuating Job1 and /or Job2

Hysteresis: To avoid job have been activated too often, option available to set for no reaction in 0.1% to 10% of full span (Low Scale to High Scale).

Job1, Job2: When an event occurs, the task to be performed is called the job. A typical example is to trigger sound buzzer in event of high temperature. Each pen can accept five events (or alarms) and each event can create two jobs. Various types of jobs can be selected.

6.2.3.3.5 Jobs

The following jobs are available for configuration to be executed on an event

No Action: Do nothing

Log Alarm (Auto Ack): Record alarm with acknowledgement automatically

Log Alarm: Record alarms

Log Event: Record events

Send Email: Send email if it is configured on an event

Sound Buzzer: Sound the buzzer on an event

DO Latch On: Set digital output / relay on, and then select Target say DO 1. The relay is latched when it is activated. Digital Output relays will be shown if digital output IO module is configured and available in database

DO Latch Off: Set digital output / relay off, and then select Target say DO 1. The relay is latched when it is activated. Digital Output relays will be shown if digital output IO module is configured and available in database

DO Process: Set digital output / relay on for process high or low, and then select Target from DO 1 to DO 6. The relay is not going to be latched when it is activated. Digital Output relays will be shown if digital output IO module is configured and available in database

Enable Timer: Start the timer, and then select Target from Timer1 to Timer 100 or all Timers

Disable Timer: Stop the timer, and then select Target from Timer1 to Timer 100 or all Timers

Preset Totalz: Start the totalizer with a preset value, and then select Target from Tolz 1 to Tolz 50. It requires configuring totalizer via tools and enabling it to appear totalizer number in the jobs after selecting Preset Totalizer

Reset Totalz: Reset totalizer into zero, and then select Target from Tolz 1 to Tolz 50. It requires configuring totalizer and enabling it to appear totalizer number in the jobs after selecting Preset Totalizer

Enable Totalz: Start the totalizer, and then select Target from Tolz 1 to Tolz 50. It requires configuring totalizer and enabling it to appear totalizer number in the jobs after selecting Preset Totalizer

Disable Totalz: Stop the totalizer, and then select Target from Tolz 1 to Tolz 50. It requires configuring totalizer and enabling it to appear totalizer number in the jobs after selecting Preset Totalizer

- Preset Counter:** Start the Counter with a preset value, and then select Target from Cont 1 to Cont 50. It requires configuring Counter via tools to appear counter number after selection of Preset counter in the jobs
- Reset Counter:** Resets the counter into zero, and then select Target from Cont 1 to Cont 50.
- Inc Counter:** Increase the counter, and then select Target from Cont 1 to Cont 50
- Dec Counter:** Decrease the counter, and then select Target from Cont 1 to Cont 50
- Log Report:** Make the report for Counter and Totalizer
- Reset MinMaxAve:** In Report function, after logging the Min/Max/Ave data of AI and Math channels for one day for example, then reset historical data in order to logging new data for the next day
- Log Message:** Log customized comments for alarm as messages on an event. A total of 100 messages available for customer customization
- Print Historical Data:** Prints the historical data as per print auto output configuration.
- Print Event List:** Prints the event list as per print auto output configuration.
- Print Report List (Min/Max/Ave):** Prints the report list as per print auto output configuration.
- Print Snapshot:** Prints the snapshot of the screen.
- Output Historical Data:** Output historical data to csv format as per print auto-output configuration.
- Log Report (Instant):** Log the report with instant values.

6.2.3.3.6 Display Page Configuration

The display page configuration will allow the user to configure the display pages as per the requirement. The display pages will be auto configured along with the auto channel configuration. The user can modify the channel and pages as per their requirement. There are 200 display pages available in Total with 24 pens/page.

- Mode:** This is for page enable or disable.
- Page Marks:** This is the name for specific page. Ex: Section Kiln. Maximum 38 characters are allowed
- Speed:** This is real time trend display resolution. Select one of the options in 1 sec/dot, 2 sec/dot, 5 sec/dot, 10 sec/dot, 15 sec/dot, 20 sec/dot, 30 sec/dot, 1 min/dot, 2 min/dot, 5 min/dot, 10 min/dot, 15 min/dot, 1 hour/dot, 2 hour/dot, 10 min/page, 30 min/page, 1 hr/page, 2 hrs/page, 4 hrs/page, 8 hrs/page, 12 hour/page, day/page and week/page. If you wish to see both Real time and historical combined, then, select say day/page at the display. Then, the Real time trend in screen will be for the last 24 hrs update dynamically
- Direction:** Selects the trend direction horizontal or vertical.
- Background:** Defines the background color of Trend mode in black or white
- Pen:** Defines a specific channel as a drawing pen, its color, width, Display Hi and Display Low.
- Channel:** Selects a specific analog input AI or Mathematics Math, or selects Disable if a specific channel is not required.
- Color:** Selects the color for each pen.
- Width:** Selects the width of trend, 1-thin, 2-medium, 3-wide.
- Low:** Defines the low scale for a pen on the display.
- High:** Defines the high scale for a pen on the display.
- Forward / backward button:** It is to navigate to next/earlier 8 sets of pens for display configuration

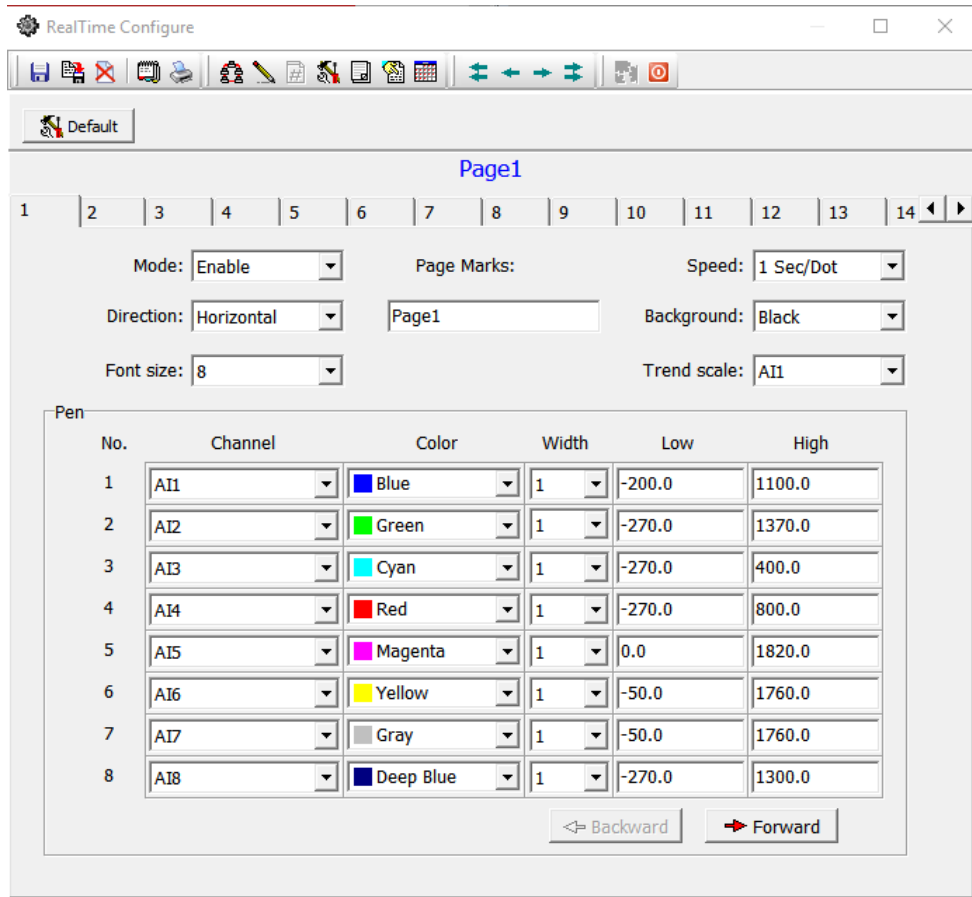

6.2.3.3.7 Tools Configuration

The real time viewer has Timers, counters, Totalizers as tools for the user to use as per the application requirement.

1. Timers

Maximum 100 timers available for configuration

Type: Countdown, Repeat Countdown, Daily, Weekly or Monthly.

Countdown: Defines the interval of time, e.g. days, hours, minutes and seconds. (Not Real Time clock)

Repeat Countdown: Repeats the previous countdown.

Daily, Weekly or Monthly: The timer works in selected interval of Real Time clock

Action: Disables or enables the timer.

Job1, Job2: various jobs as described in jobs for each timer.

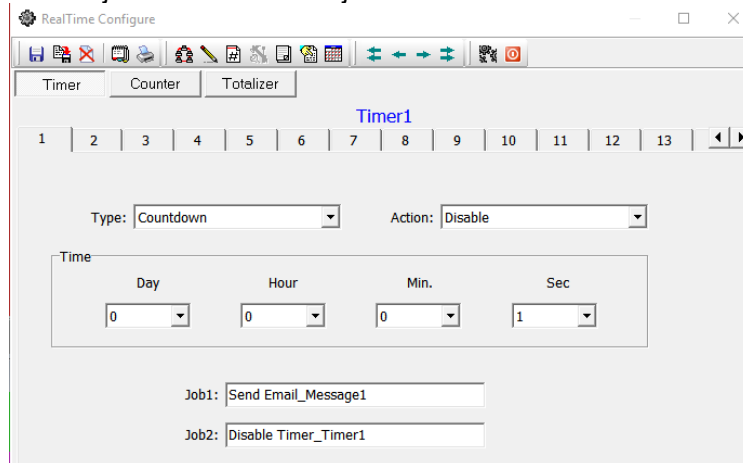

2. Counters

Maximum 50 counters are available.

Name: Defines the name of counter.

Desc: Defines the description for a specific counter on the display.

Unit: Defines the unit of counter

Preset: Defines the preset value for the counter. The counter starts from a preset value.

Event: Defines the type, set point, Job1 or Job2.

Type: Select one of three options: None, Process Hi, Process Low

Set point: Defines the set point of process value to trigger the counter.

Job1, Job2: various jobs as described in jobs for each counter

No.	Type	SetPoint	Log	Job1	Job2
1	NO	100	Log Alarm(AutoAck)	No Action	No Action
2	NO	100	Log Alarm(AutoAck)	No Action	No Action

3. Totalizers

Maximum 50 Totalizers are available.

Name: Defines the name of the totalizer.

Desc: Defines the description for a specific totalizer on the display.

Source: Select a specific analog input or Math input to be used for totalizing.

Action: Disables or enables the totalizer.

Decimal: Defines the decimal point for the totalizer.

Period: Selects second, minute or hour used for the totalizer.

Unit: Defines the unit of totalizing

Preset: Defines the preset value for the totalizer. The totalizer starts from a preset value.

Low Cut: If Source channel has below this setting, then value is skipped from Totalizing

Event: Defines the type, set point, Job1 or Job2.

Type: Select one of three options: None, Process Hi, Process Low

Set point: Defines the set point of process value to trigger the totalizer.

Job1, Job2: various jobs as described in jobs for each totalizer.

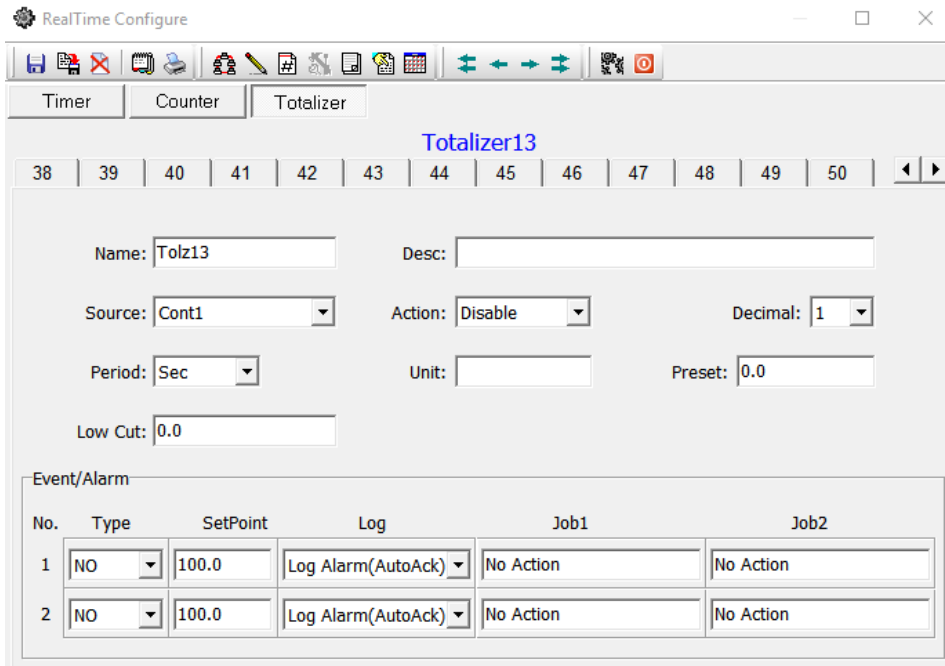

6.2.3.3.8 Comments

There are 100 comments available to customize the alarm messages. The user can select one comment from this list when log message or send Email jobs are configured. Each comment can accept maximum of 50 characters.

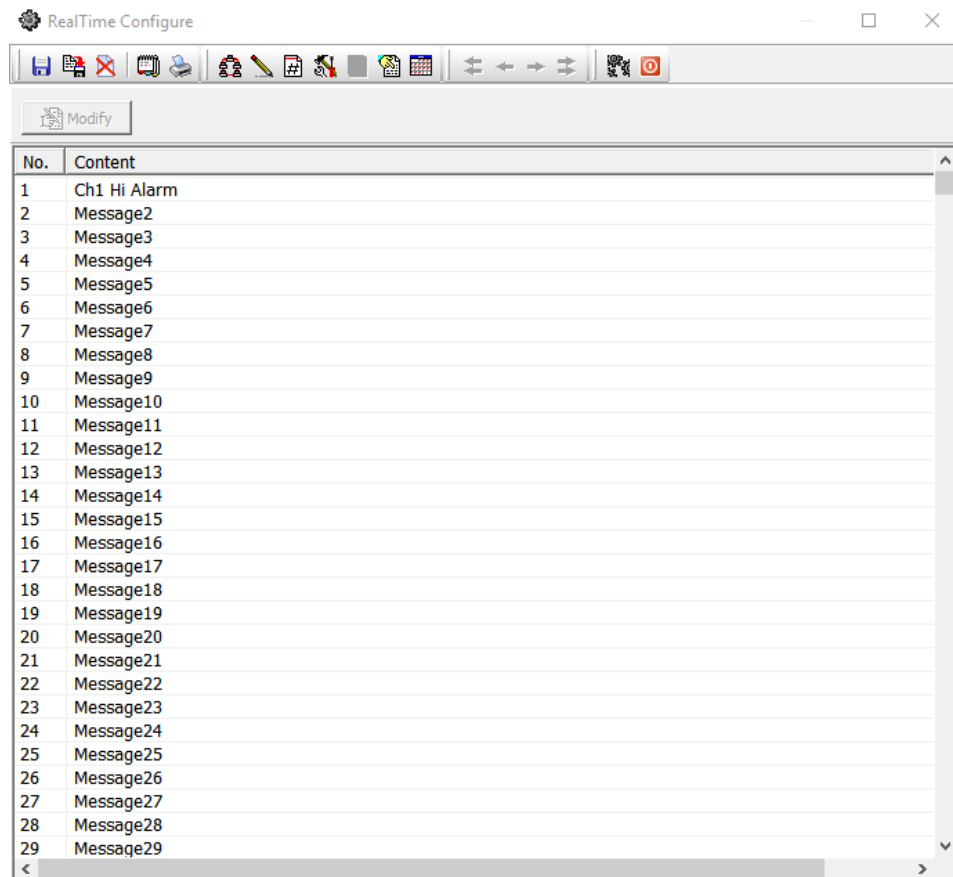

6.2.3.3.9 Auto Configuration

The Auto configuration will automatically configure the tags from recorder, IO Module and controllers. This will simplify the project setup procedure.

Device type: Select Recorder (PR) for addition of Recorder into network

Bank: Select bank from 1 to 4 as per bank configuration

Auto-update: Select if it is required to acquire data base of Recorders and give tag name for the channels automatically

IP Address: IP address of the Recorder. After entering the IP address press '+' to add to IP List.

IP List: IP List of the Recorders. If any recorder needs to be removed from the list then select the IP address from the list then press '-' to remove the IP from the list.

Use Converter: Device Node Address: If the device is connected to PC via PC-E converter then select this option and enter the node address of the device.

From: Start address of device in RS485 network.

To: End address of device in RS485 network. This is not applicable for Recorders.

Click on "OK" to add all the Recorders into network configuration

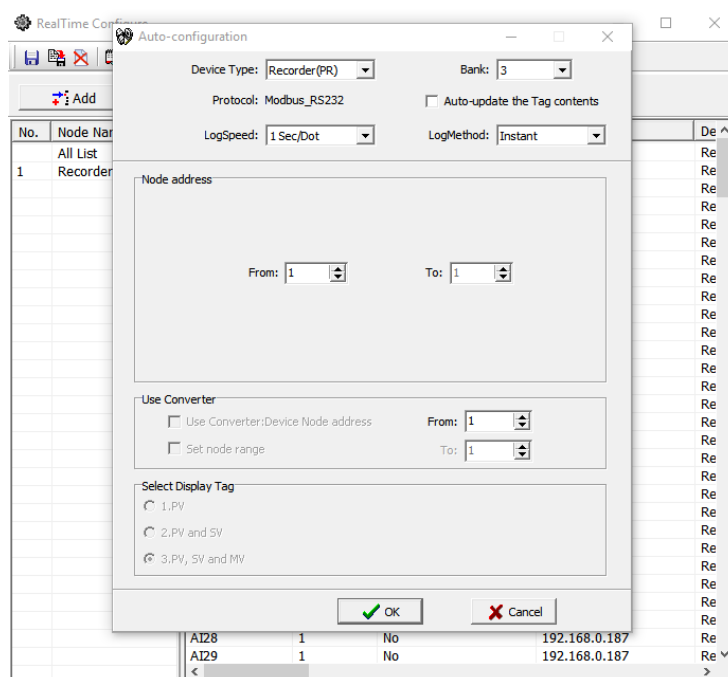
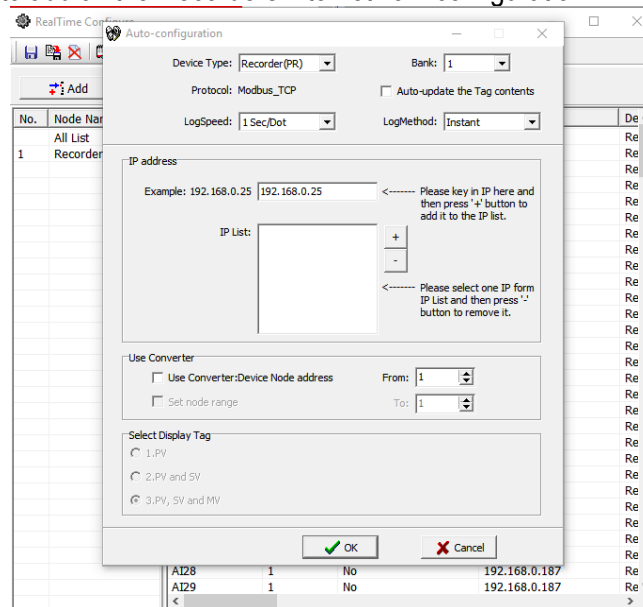

6.2.3.4 Create a New Project

To create a new project follow the below steps.

1. Click the icon  or select New from File Menu.
2. Set a name for the project

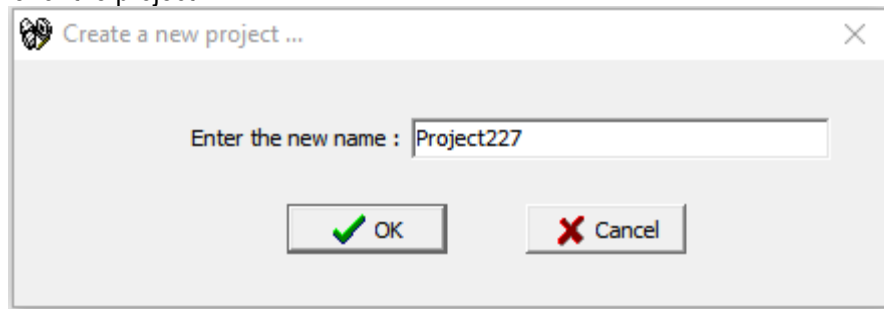

3. The Software requests the user for auto configuration. Press No to configure the communication banks.

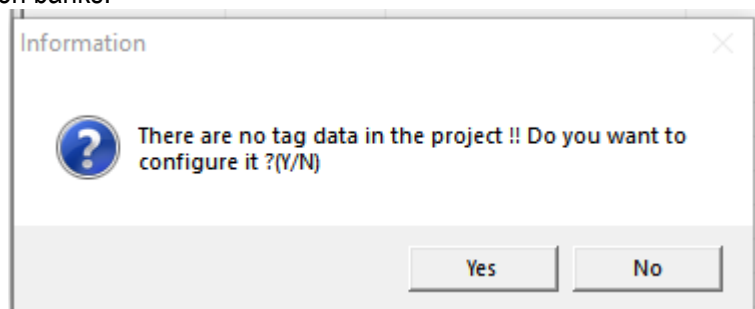

4. Click Bank icon  to configure communication bank.

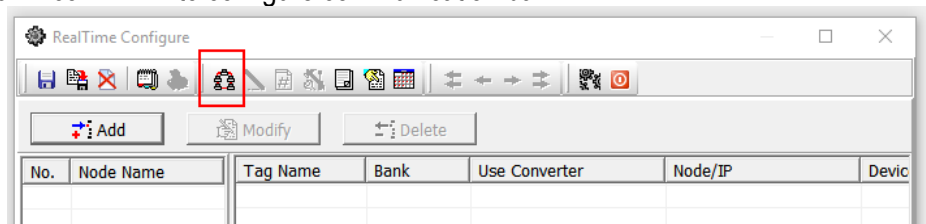

5. There are 4 different banks are available for the user to configure. It will allow the software to read the data from different communication networks like RS232, RS485, and Ethernet.
 - 5.1. If the device is connected to PC via Ethernet port then configure the bank with Protocol as Modbus_TCP and port no as 502.

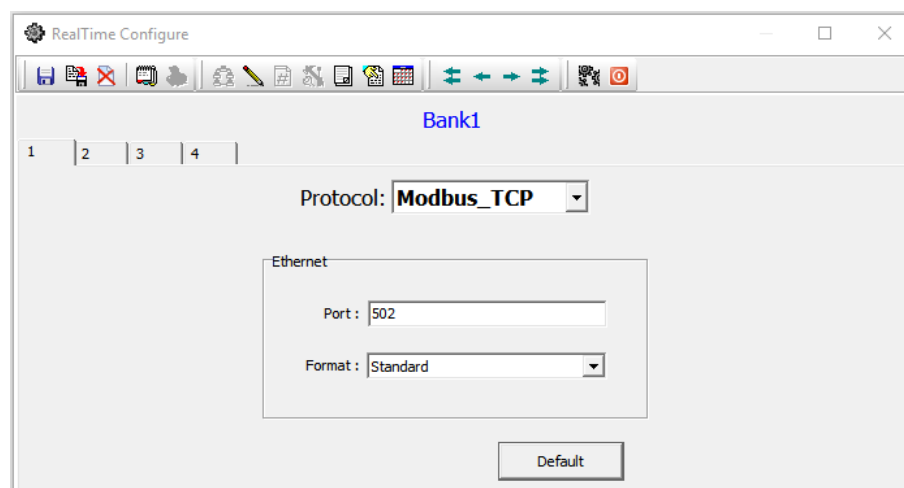

- 5.2. If the device is connected to PC via RS232 or RS485 port then configure the bank with Protocol as Modbus_RS232 and other communication parameters such as com port no, Baud Rate, Parity, Data Bits and Stop Bits as per the connection.

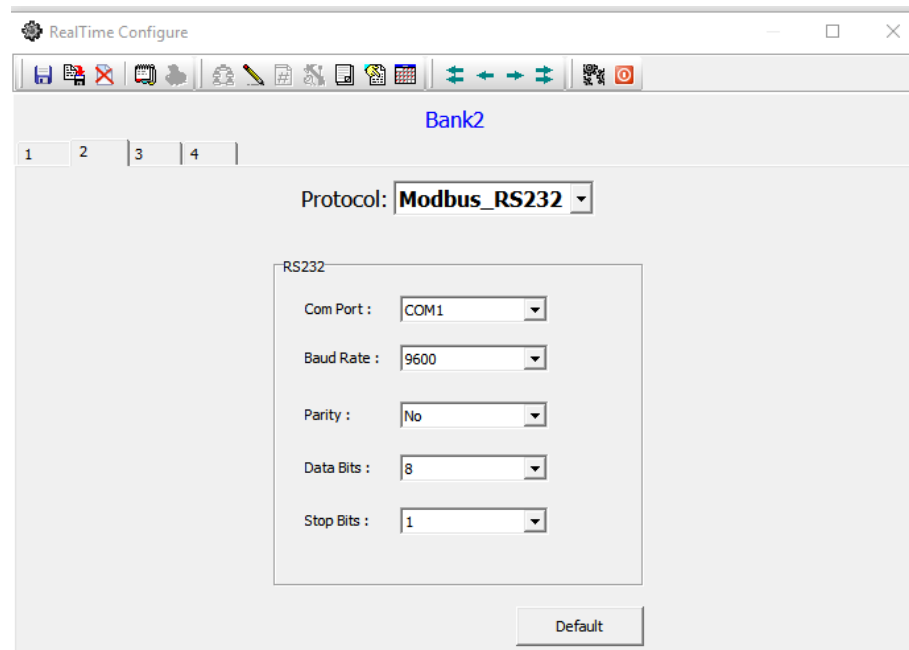

- 5.3. After configuring the banks, close the configuration viewer and restart the program.

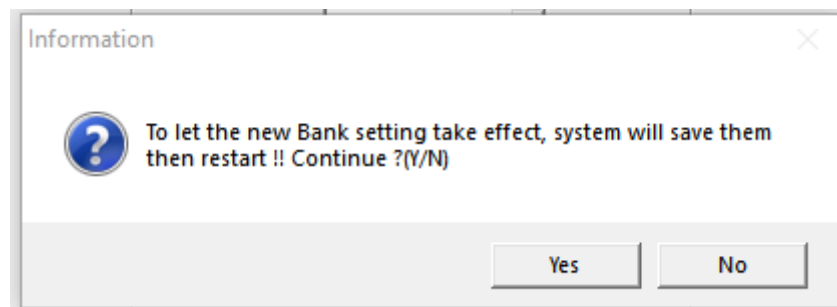

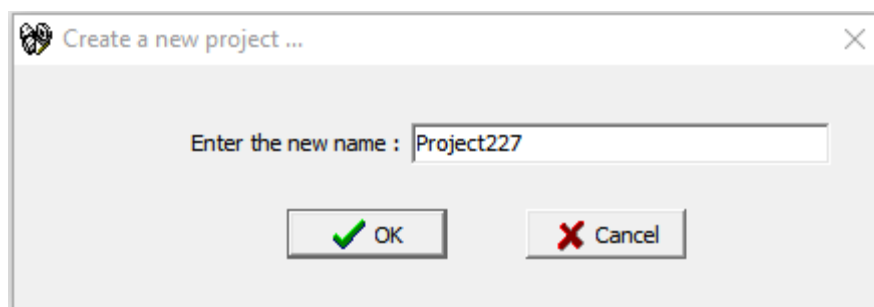

6. Click the icon  or select New from File Menu.
7. Set a name for the project

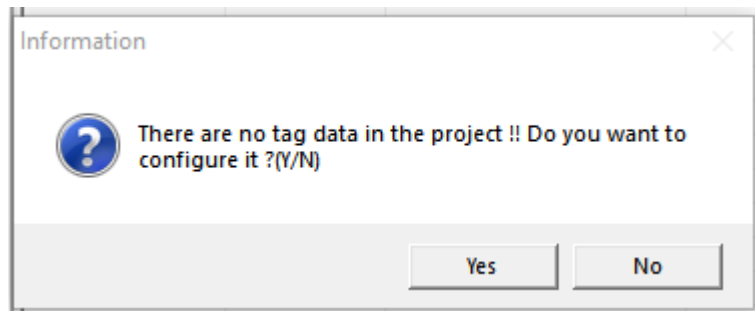

8. The Software requests the user for auto configuration. Press yes to configure the tags of the device automatically by the software.



9. Add the device to the project as per the connection.
 - 9.1. Select Recorder (PR) as device type to read the data from PPS series Recorder.
 - 9.2. Select the Bank as per the connection and select the check box of Auto-update Tag contents to update the tags automatically.
 - 9.3. Configure the log speed and log method
 - 9.4. Enter the IP address and press  key to add the device to the project. If there are any existing devices in the list and needs to be removed then select the IP address and press  key to remove.

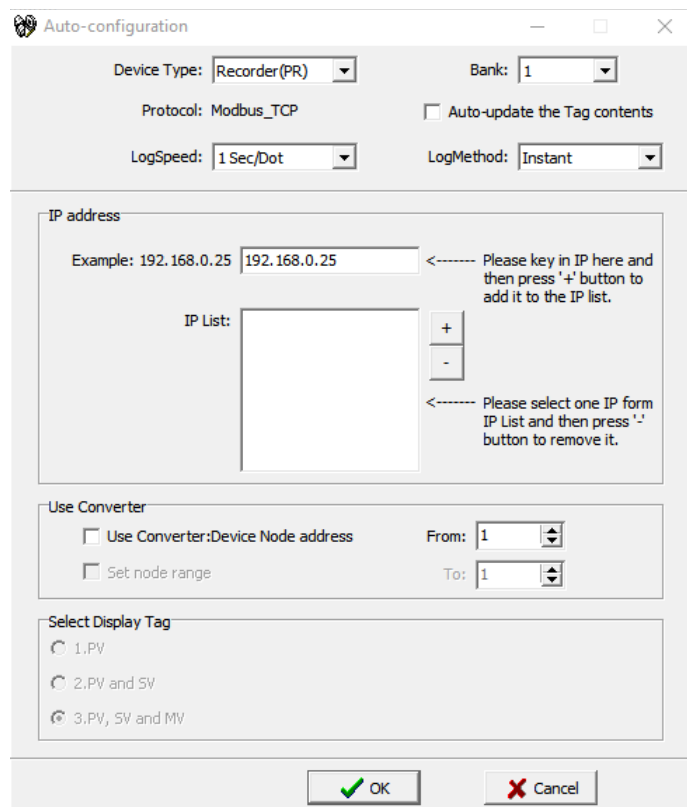

- 9.5. If the device is connected via Ethernet to RS485 converter PC-E then select the check box use converter: Device Node Address and enter the node address of the device. If multiple devices are connected via PC-E Converter then select the Set node range check box and enter the starting and end node addresses.
- 9.6. Press OK to establish the communication and auto update the tags from the recorder.

No.	Node Name	Tag Name	Bank	Use Converter	Node/IP	Devic
	All List	A11	1	Yes	1 / 192.168.0.227	Recon
1	Recorder(PR)	A12	1	Yes	1 / 192.168.0.227	Recon
		A13	1	Yes	1 / 192.168.0.227	Recon
		A14	1	Yes	1 / 192.168.0.227	Recon
		A15	1	Yes	1 / 192.168.0.227	Recon
		A16	1	Yes	1 / 192.168.0.227	Recon
		DI1	1	Yes	1 / 192.168.0.227	Recon
		DI2	1	Yes	1 / 192.168.0.227	Recon
		DI3	1	Yes	1 / 192.168.0.227	Recon
		DI4	1	Yes	1 / 192.168.0.227	Recon
		DI5	1	Yes	1 / 192.168.0.227	Recon
		DI6	1	Yes	1 / 192.168.0.227	Recon
		AO1	1	Yes	1 / 192.168.0.227	Recon
		AO2	1	Yes	1 / 192.168.0.227	Recon
		AO3	1	Yes	1 / 192.168.0.227	Recon
		AO4	1	Yes	1 / 192.168.0.227	Recon
		AO5	1	Yes	1 / 192.168.0.227	Recon
		AO6	1	Yes	1 / 192.168.0.227	Recon
		DO1	1	Yes	1 / 192.168.0.227	Recon
		DO2	1	Yes	1 / 192.168.0.227	Recon
		DO3	1	Yes	1 / 192.168.0.227	Recon
		DO4	1	Yes	1 / 192.168.0.227	Recon
		DO5	1	Yes	1 / 192.168.0.227	Recon
		DO6	1	Yes	1 / 192.168.0.227	Recon

9.7. If there are more than one device is added to the project then the tag configuration of all the devices will be listed as below.

No.	Node Name	Tag Name	Bank	Use Converter	Node/IP	Devic
	All List	A1_2	1	No	192.168.0.107	Recon
1	Recorder(PR)	A2_2	1	No	192.168.0.107	Recon
2	Recorder(PR)_2	A3_2	1	No	192.168.0.107	Recon
		A4_2	1	No	192.168.0.107	Recon
		Math1_2	1	No	192.168.0.107	Recon
		Totalizer1_2	1	No	192.168.0.107	Recon
		CG2-MV1_2	1	No	192.168.0.107	Recon
		CG2-PV_2	1	No	192.168.0.107	Recon
		CI_PV_2	1	No	192.168.0.107	Recon
		CI_SV_2	1	No	192.168.0.107	Recon
		CI_ALM_2	1	No	192.168.0.107	Recon
		CI_EROR_2	1	No	192.168.0.107	Recon
		CI_ProfileERR...	1	No	192.168.0.107	Recon

No.	Node Name	Tag Name	Bank	Use Converter	Node/IP	Devic
	All List	A11	1	No	192.168.0.227	Recon
1	Recorder(PR)	A12	1	No	192.168.0.227	Recon
2	Recorder(PR)_2	A13	1	No	192.168.0.227	Recon
		A14	1	No	192.168.0.227	Recon
		A15	1	No	192.168.0.227	Recon
		A16	1	No	192.168.0.227	Recon
		DI1	1	No	192.168.0.227	Recon
		DI2	1	No	192.168.0.227	Recon
		DI3	1	No	192.168.0.227	Recon
		DI4	1	No	192.168.0.227	Recon
		DI5	1	No	192.168.0.227	Recon
		DI6	1	No	192.168.0.227	Recon
		AO1	1	No	192.168.0.227	Recon
		AO2	1	No	192.168.0.227	Recon
		AO3	1	No	192.168.0.227	Recon
		AO4	1	No	192.168.0.227	Recon
		AO5	1	No	192.168.0.227	Recon
		AO6	1	No	192.168.0.227	Recon
		DO1	1	No	192.168.0.227	Recon
		DO2	1	No	192.168.0.227	Recon
		DO3	1	No	192.168.0.227	Recon
		DO4	1	No	192.168.0.227	Recon
		DO5	1	No	192.168.0.227	Recon
		DO6	1	No	192.168.0.227	Recon

10. Close the Real time configuration viewer to update the tag contents and logging the data from the configured devices to PC. The configuration Viewer can be closed by pressing the X key on the right side top or  key.

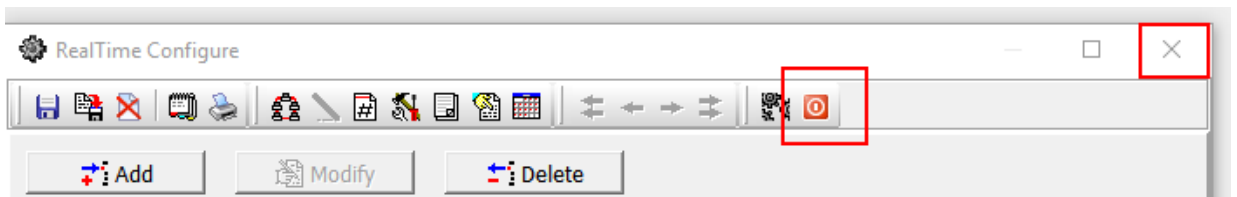

11. Press yes to apply the new settings to the project.

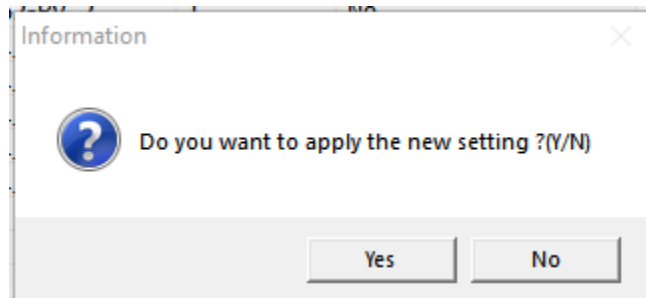

12. If the USB Licence key is not plugged to the USB port of the PC then the Software will show the warning message and start the demo mode. The software will stop working after the demo period.

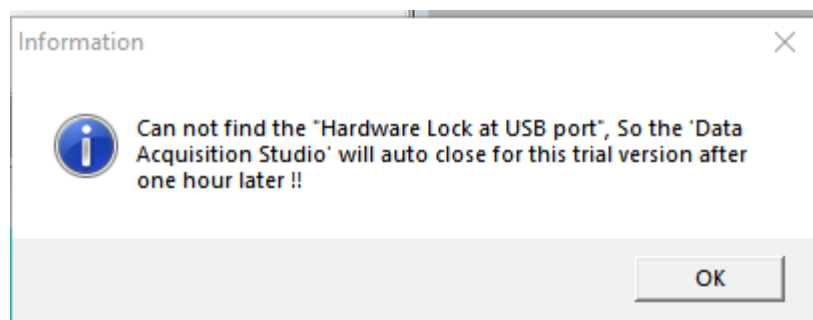

13. Press OK to start in demo mode.

14. If the USB Licence key is plugged in to the USB Port of the PC then the software will start reading the data from the devices and log the data to the PC.

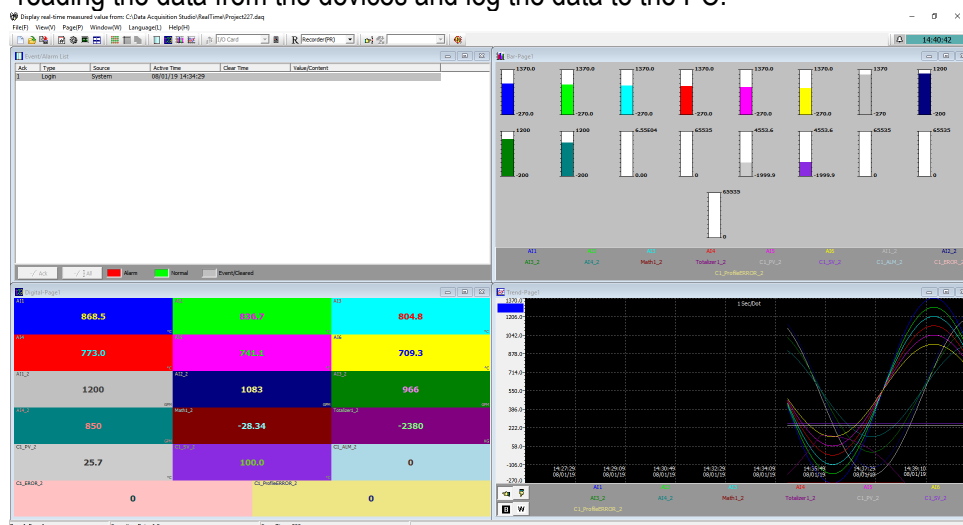

6.2.3.5 Open an Existing Project

To open an existing project the following procedures to be followed.

1. Click the icon  or select Open from File Menu.
2. The software will list the projects from the default project path for the user to select.

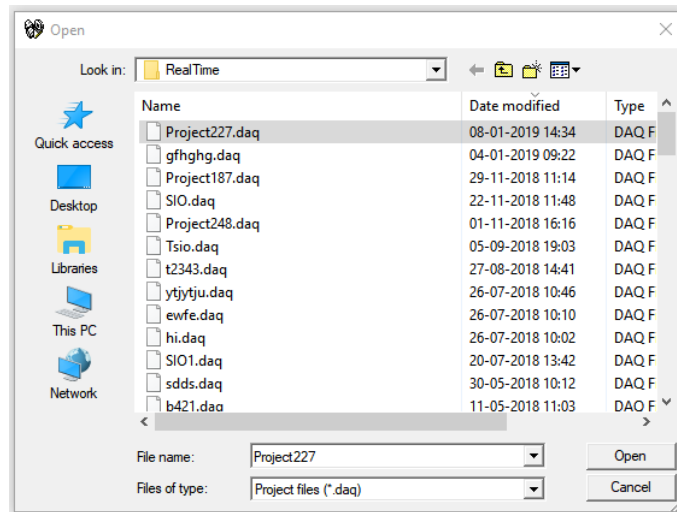

3. Select the project and click Open to open the project.
4. If the USB Licence key is not plugged to the USB port of the PC then the Software will show the warning message and start the demo mode. The software will stop working after the demo period.

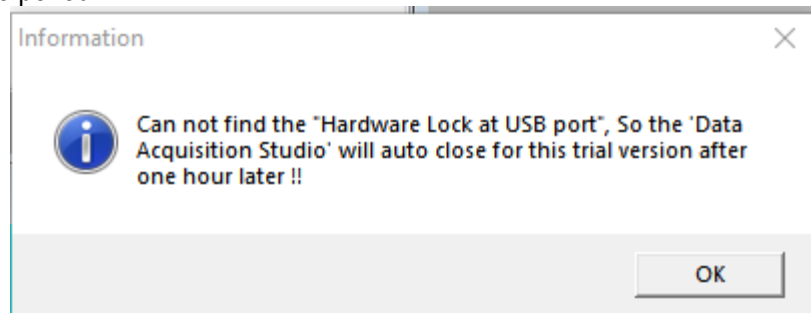

5. Press OK to start in demo mode.
6. If the USB Licence key is plugged in to the USB Port of the PC then the software will start reading the data from the devices and log the data to the PC.

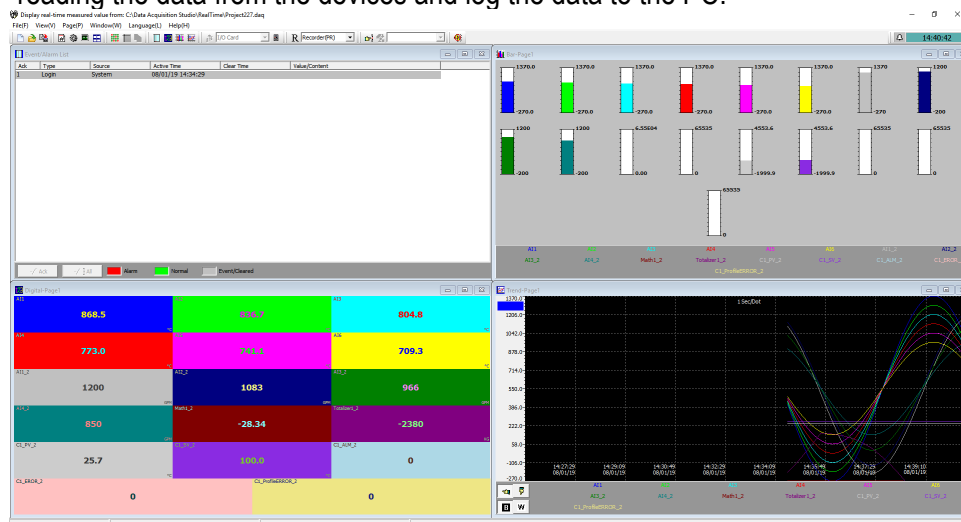

6.2.3.6 Add a Device to the Existing Device

It is possible to add a device to the existing project and log the data. For adding the device to the existing project follow the procedure as follows.

7. Open the project by using Open project option as explained above.
8. Go to Configuration by using Configuration data in the View menu or  icon on the Tool bar.

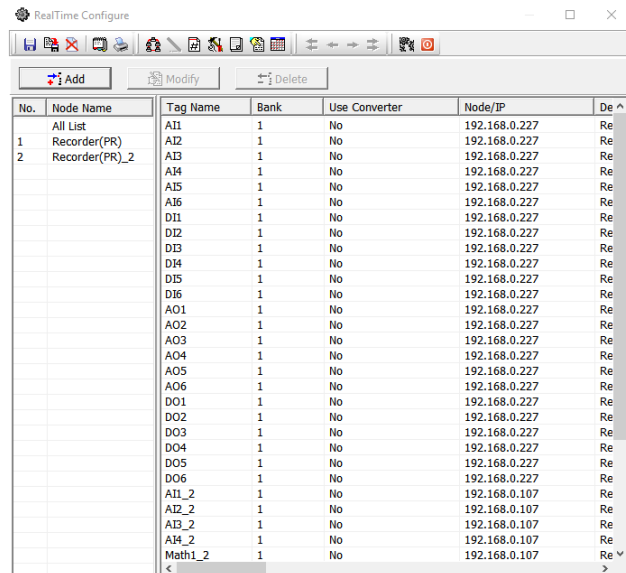

No.	Node Name	Tag Name	Bank	Use Converter	Node/IP	De ^
	All List	AI1	1	No	192.168.0.227	Re
1	Recorder(PR)	AI2	1	No	192.168.0.227	Re
		AI3	1	No	192.168.0.227	Re
2	Recorder(PR)_2	AI4	1	No	192.168.0.227	Re
		AI5	1	No	192.168.0.227	Re
		AI6	1	No	192.168.0.227	Re
		DI1	1	No	192.168.0.227	Re
		DI2	1	No	192.168.0.227	Re
		DI3	1	No	192.168.0.227	Re
		DI4	1	No	192.168.0.227	Re
		DI5	1	No	192.168.0.227	Re
		DI6	1	No	192.168.0.227	Re
		AO1	1	No	192.168.0.227	Re
		AO2	1	No	192.168.0.227	Re
		AO3	1	No	192.168.0.227	Re
		AO4	1	No	192.168.0.227	Re
		AO5	1	No	192.168.0.227	Re
		AO6	1	No	192.168.0.227	Re
		DO1	1	No	192.168.0.227	Re
		DO2	1	No	192.168.0.227	Re
		DO3	1	No	192.168.0.227	Re
		DO4	1	No	192.168.0.227	Re
		DO5	1	No	192.168.0.227	Re
		DO6	1	No	192.168.0.227	Re
		AI1_2	1	No	192.168.0.107	Re
		AI2_2	1	No	192.168.0.107	Re
		AI3_2	1	No	192.168.0.107	Re
		AI4_2	1	No	192.168.0.107	Re
		Math1_2	1	No	192.168.0.107	Re

9. Click Add and configure the device information to add additional device to the project.

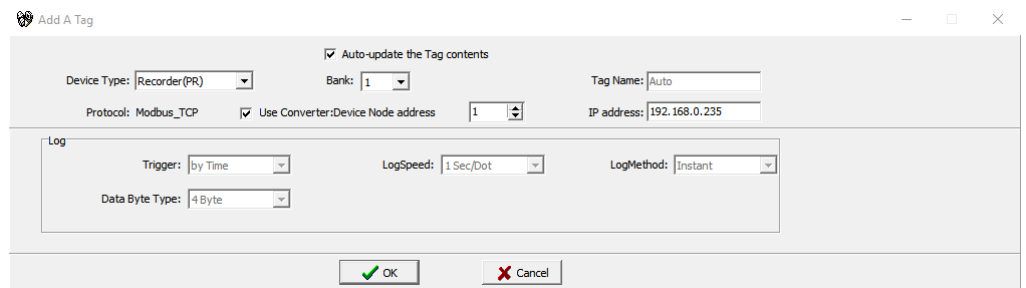

Auto-update the Tag contents
 Device Type: Recorder(PR) Bank: 1 Tag Name: Auto
 Protocol: Modbus_TCP Use Converter:Device Node address IP address: 192.168.0.235
 Log
 Trigger: by Time LogSpeed: 1 Sec/Dot LogMethod: Instant
 Data Byte Type: 4 Byte

10. Now the real time configuration will update the tags with new device information.

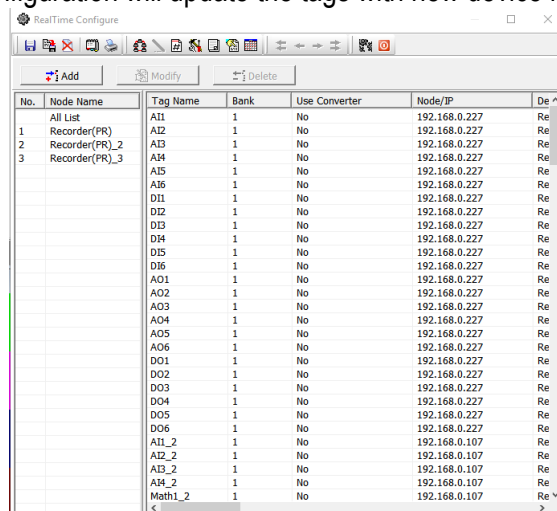

No.	Node Name	Tag Name	Bank	Use Converter	Node/IP	De ^
	All List	AI1	1	No	192.168.0.227	Re
1	Recorder(PR)	AI2	1	No	192.168.0.227	Re
		AI3	1	No	192.168.0.227	Re
2	Recorder(PR)_2	AI4	1	No	192.168.0.227	Re
		AI5	1	No	192.168.0.227	Re
3	Recorder(PR)_3	AI6	1	No	192.168.0.227	Re
		DI1	1	No	192.168.0.227	Re
		DI2	1	No	192.168.0.227	Re
		DI3	1	No	192.168.0.227	Re
		DI4	1	No	192.168.0.227	Re
		DI5	1	No	192.168.0.227	Re
		DI6	1	No	192.168.0.227	Re
		AO1	1	No	192.168.0.227	Re
		AO2	1	No	192.168.0.227	Re
		AO3	1	No	192.168.0.227	Re
		AO4	1	No	192.168.0.227	Re
		AO5	1	No	192.168.0.227	Re
		AO6	1	No	192.168.0.227	Re
		DO1	1	No	192.168.0.227	Re
		DO2	1	No	192.168.0.227	Re
		DO3	1	No	192.168.0.227	Re
		DO4	1	No	192.168.0.227	Re
		DO5	1	No	192.168.0.227	Re
		DO6	1	No	192.168.0.227	Re
		AI1_2	1	No	192.168.0.107	Re
		AI2_2	1	No	192.168.0.107	Re
		AI3_2	1	No	192.168.0.107	Re
		AI4_2	1	No	192.168.0.107	Re
		Math1_2	1	No	192.168.0.107	Re

11. Close the Real time Configuration Viewer to update the project with the new device.

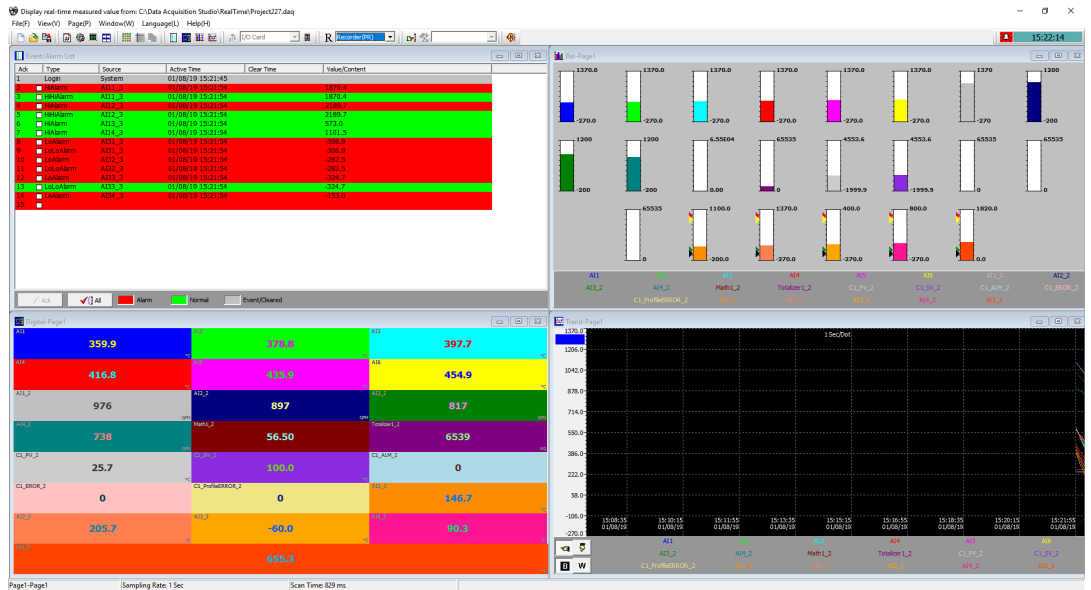

6.2.3.7 PR-DAQ RS485 Communication

The recorder can be connected to real time viewer software using RS232 or RS485 port of recorder and PC by following the below procedure.

1. Save the PR Configuration to the SD card or USB Disk depends on the selection of External Storage in Instrument Menu.
2. Press the Save Button on the Configuration page to Save the PR Configuration to the SD card or USB Disk.

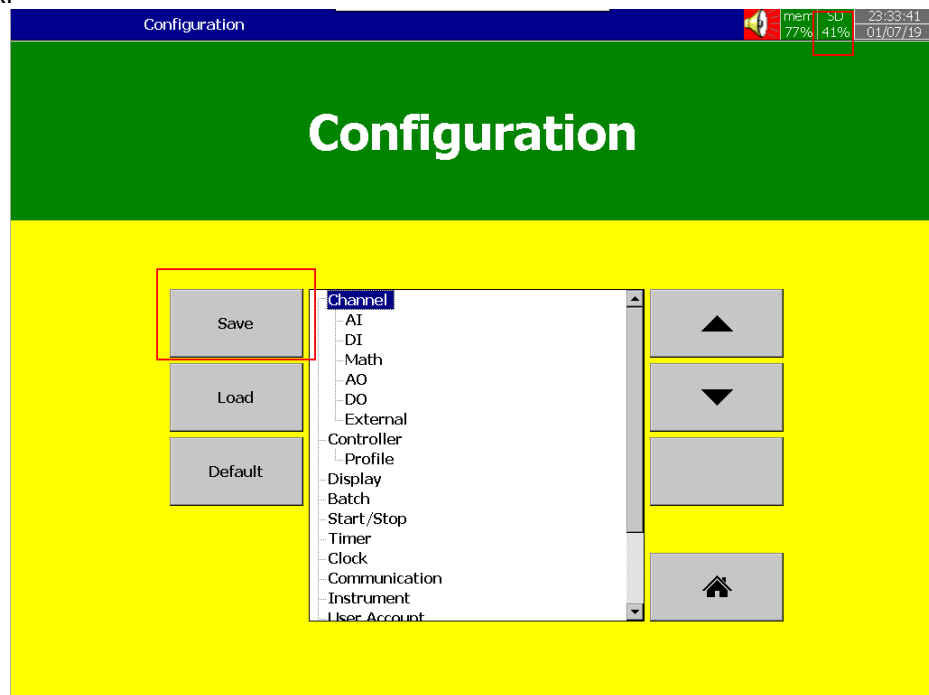

3. Remove SD card or USB Disk from PR
4. Connect the SD Card or USB Disk to PC.
5. Open Real time Viewer in DAQ Software
6. Set the Bank and PR Communication Parameter properly for RS485 Communication.

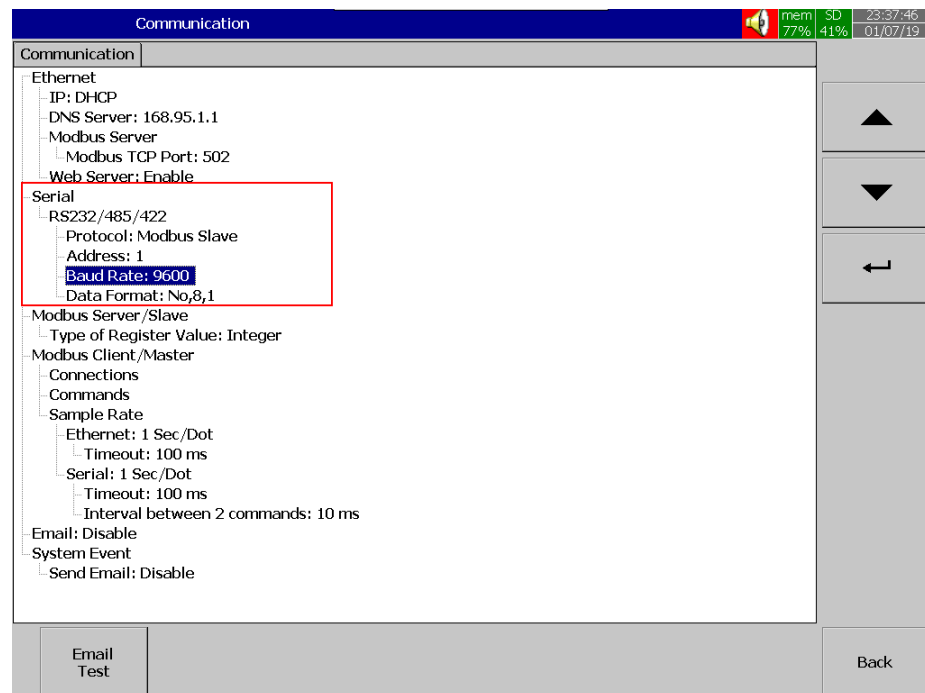
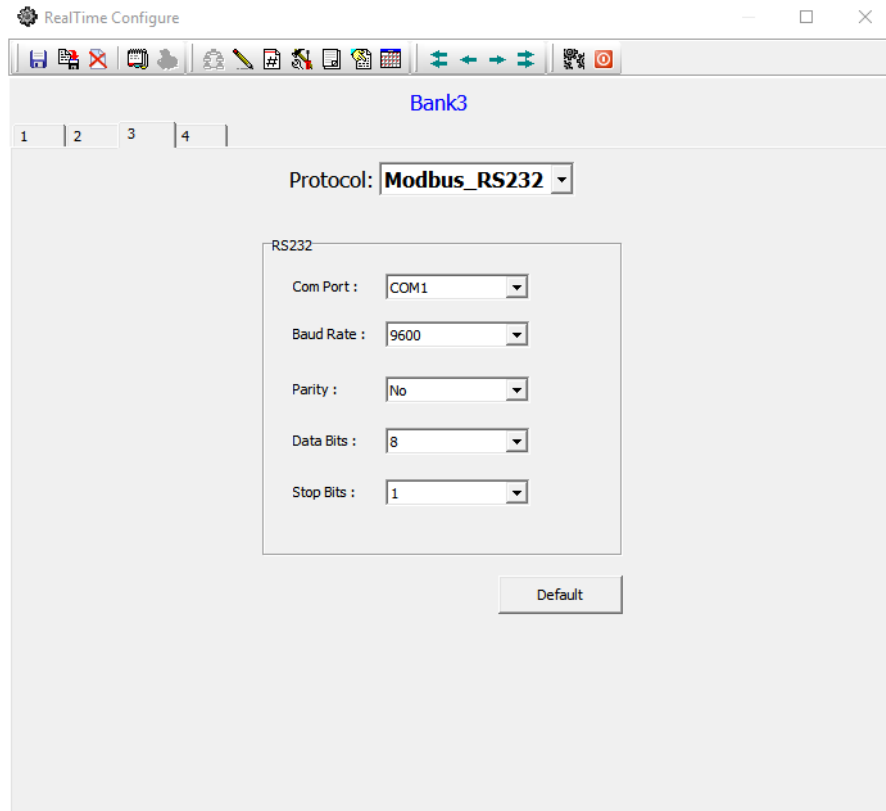

7. Create a new project
8. Select Device Type as PR and select the Bank related to RS485 setting

No.	Node Name	Tag Name	Bank	Use Converter	Node/IP	De
	All List	A11	3	No	1	Re
1	Recorder(PR)	A12	3	No	1	Re
		A13	3	No	1	Re
		A14	3	No	1	Re
		A15	3	No	1	Re
		A16	3	No	1	Re
		A17	3	No	1	Re
		A18	3	No	1	Re
		A19	3	No	1	Re
		A110	3	No	1	Re
		A111	3	No	1	Re
		A112	3	No	1	Re
		A113	3	No	1	Re
		A114	3	No	1	Re
		A115	3	No	1	Re
		A116	3	No	1	Re
		A117	3	No	1	Re
		A118	3	No	1	Re
		A119	3	No	1	Re
		A120	3	No	1	Re
		A121	3	No	1	Re
		A122	3	No	1	Re
		A123	3	No	1	Re
		A124	3	No	1	Re
		A125	3	No	1	Re
		A126	3	No	1	Re
		A127	3	No	1	Re
		A128	3	No	1	Re
		A129	3	No	1	Re

- Close the Real time configuration viewer to update the tag contents and logging the data from the configured devices to PC. The configuration Viewer can be closed by pressing the X key on the right side top or  key.

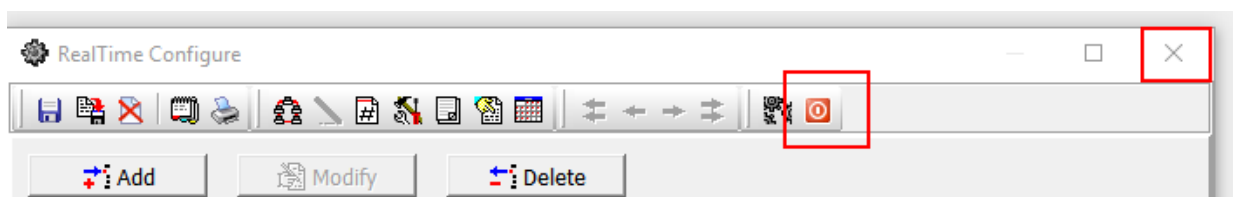

- Press yes to apply the new settings to the project.

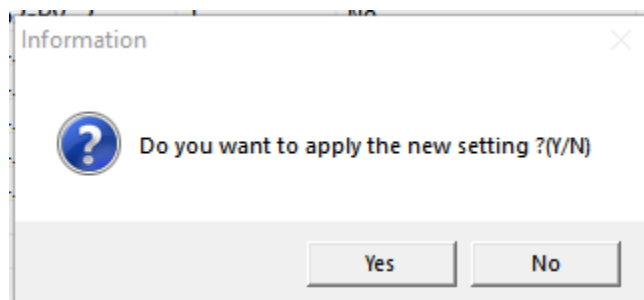

- If the USB Licence key is not plugged to the USB port of the PC then the Software will show the warning message and start the demo mode. The software will stop working after the demo period.

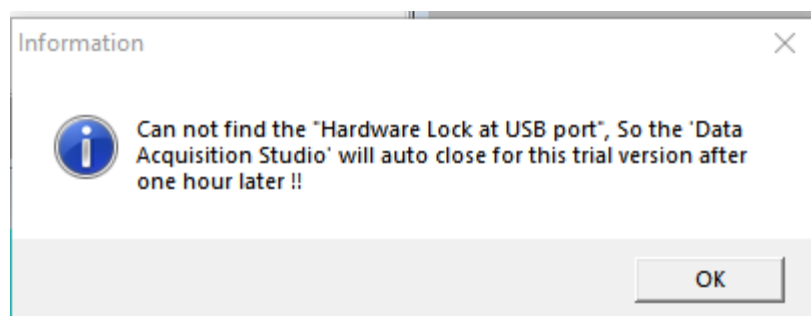

14. Press OK to start in demo mode.
15. If the USB Licence key is plugged in to the USB port of the PC then the software will start reading the data from the devices and log the data to the PC.

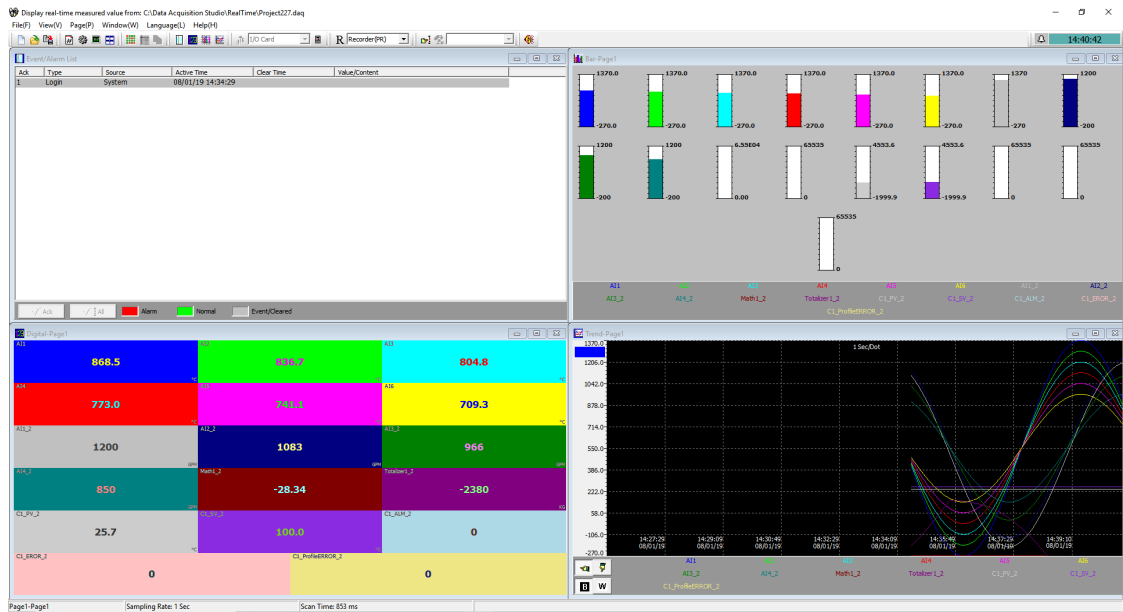



6.2.3.8 PR-DAQ Ethernet Communication

The recorder can be connected to real time viewer software using Ethernet port of recorder and PC by following the below procedure.

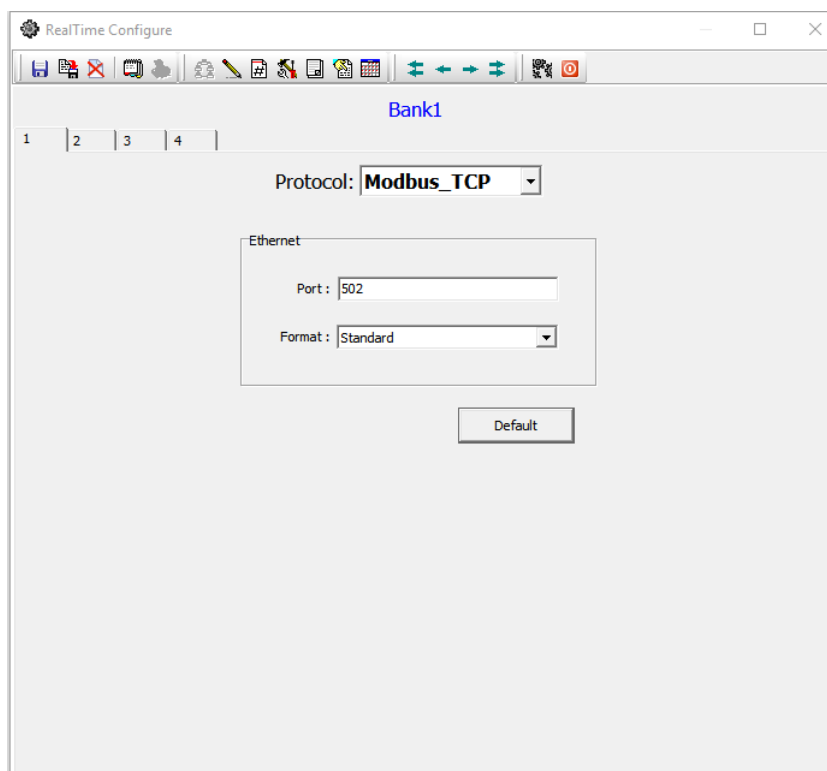
1. Open Real Time Viewer in DAQ Software
2. Set the Bank and PR Communication Parameter properly for Ethernet Communication.

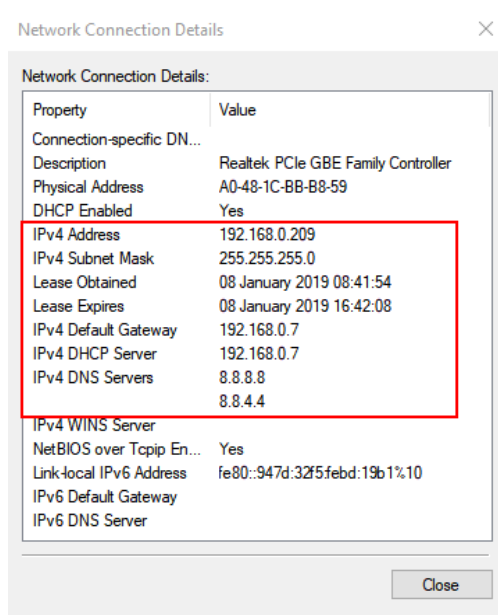
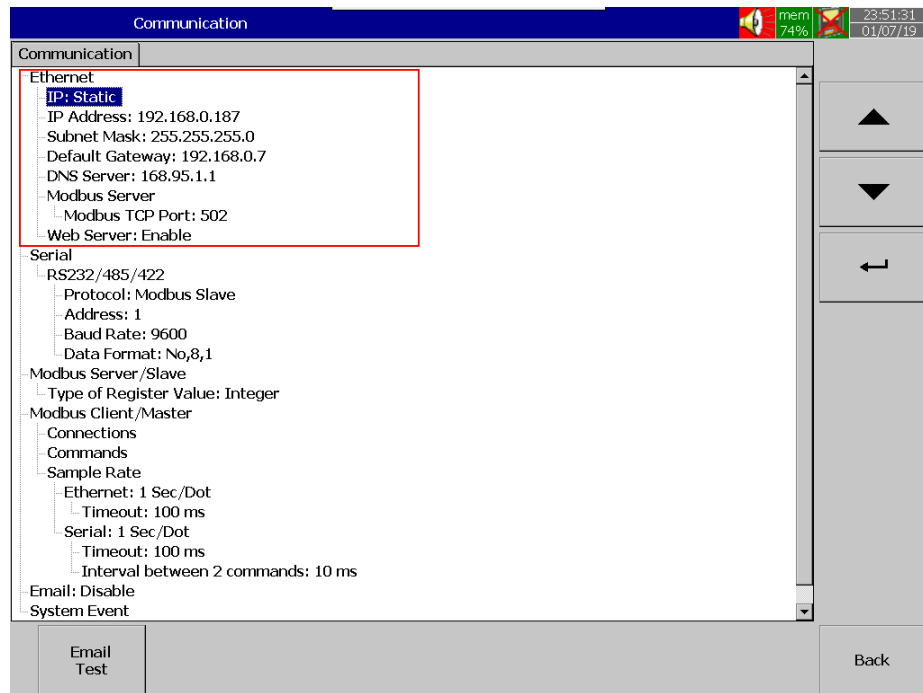



3. Create a new project
4. Select Device Type as PR and select the Bank related to Ethernet setting. Enter the IP address and press  key to add the device to the project. If there are any existing devices in the list and needs to be removed then select the IP address and press  key to remove.

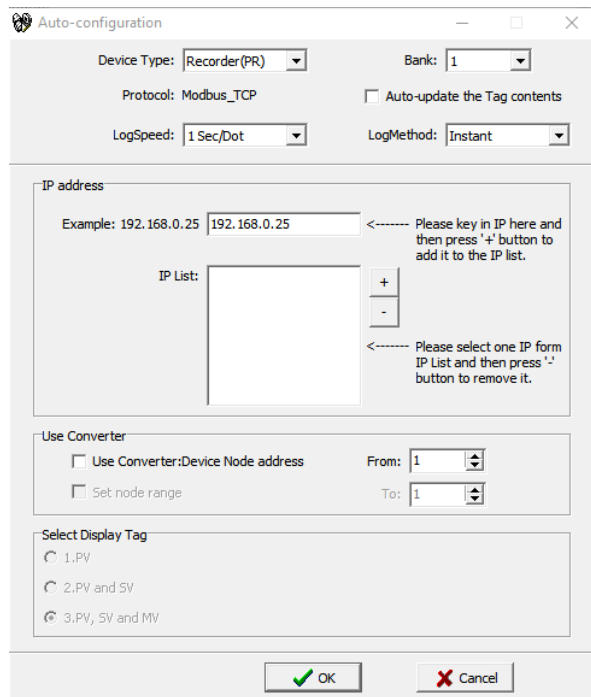

5. If the device is connected via Ethernet to RS485 converter PC-E then select the check box use converter: Device Node Address and enter the node address of the device. If multiple devices are connected via PC-E Converter then select the Set node range check box and enter the starting and end node addresses.
6. Press OK to establish the communication and auto update the tags from the recorder.

No.	Node Name	Tag Name	Bank	Use Converter	Node/IP	Devic
1	Recorder(PR)	AI1	1	Yes	1 / 192.168.0.227	Recor
		AI2	1	Yes	1 / 192.168.0.227	Recor
		AI3	1	Yes	1 / 192.168.0.227	Recor
		AI4	1	Yes	1 / 192.168.0.227	Recor
		AI5	1	Yes	1 / 192.168.0.227	Recor
		AI6	1	Yes	1 / 192.168.0.227	Recor
		DI1	1	Yes	1 / 192.168.0.227	Recor
		DI2	1	Yes	1 / 192.168.0.227	Recor
		DI3	1	Yes	1 / 192.168.0.227	Recor
		DI4	1	Yes	1 / 192.168.0.227	Recor
		DI5	1	Yes	1 / 192.168.0.227	Recor
		DI6	1	Yes	1 / 192.168.0.227	Recor
		AO1	1	Yes	1 / 192.168.0.227	Recor
		AO2	1	Yes	1 / 192.168.0.227	Recor
		AO3	1	Yes	1 / 192.168.0.227	Recor
		AO4	1	Yes	1 / 192.168.0.227	Recor
		AO5	1	Yes	1 / 192.168.0.227	Recor
		AO6	1	Yes	1 / 192.168.0.227	Recor
		DO1	1	Yes	1 / 192.168.0.227	Recor
		DO2	1	Yes	1 / 192.168.0.227	Recor
		DO3	1	Yes	1 / 192.168.0.227	Recor
		DO4	1	Yes	1 / 192.168.0.227	Recor
		DO5	1	Yes	1 / 192.168.0.227	Recor
		DO6	1	Yes	1 / 192.168.0.227	Recor

7. If there are more than one device is added to the project then the tag configuration of all the devices will be listed as below.

No.	Node Name	Tag Name	Bank	Use Converter	Node/IP	Devic
	All List	A11	1	No	192.168.0.227	Recor
1	Recorder(PR)	A12	1	No	192.168.0.227	Recor
2	Recorder(PR)_2	A13	1	No	192.168.0.227	Recor
		A14	1	No	192.168.0.227	Recor
		A15	1	No	192.168.0.227	Recor
		A16	1	No	192.168.0.227	Recor
		D11	1	No	192.168.0.227	Recor
		D12	1	No	192.168.0.227	Recor
		D13	1	No	192.168.0.227	Recor
		D14	1	No	192.168.0.227	Recor
		D15	1	No	192.168.0.227	Recor
		D16	1	No	192.168.0.227	Recor
		AO1	1	No	192.168.0.227	Recor
		AO2	1	No	192.168.0.227	Recor
		AO3	1	No	192.168.0.227	Recor
		AO4	1	No	192.168.0.227	Recor
		AO5	1	No	192.168.0.227	Recor
		AO6	1	No	192.168.0.227	Recor
		DO1	1	No	192.168.0.227	Recor
		DO2	1	No	192.168.0.227	Recor
		DO3	1	No	192.168.0.227	Recor
		DO4	1	No	192.168.0.227	Recor
		DO5	1	No	192.168.0.227	Recor
		DO6	1	No	192.168.0.227	Recor

- Close the Real time configuration viewer to update the tag contents and logging the data from the configured devices to PC. The configuration Viewer can be closed by pressing the X key on the right side top or  key.

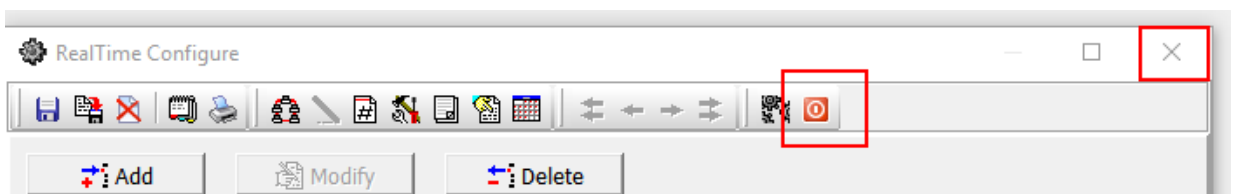

- Press yes to apply the new settings to the project.

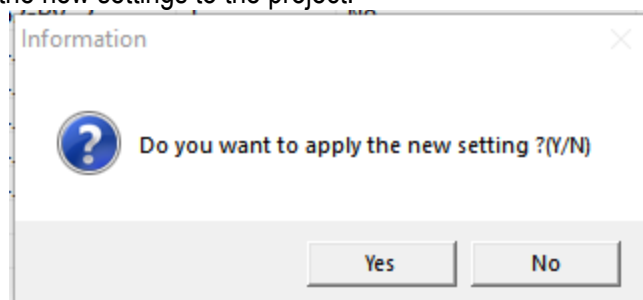

- If the USB Licence key is not plugged to the USB port of the PC then the Software will show the warning message and start the demo mode. The software will stop working after the demo period.

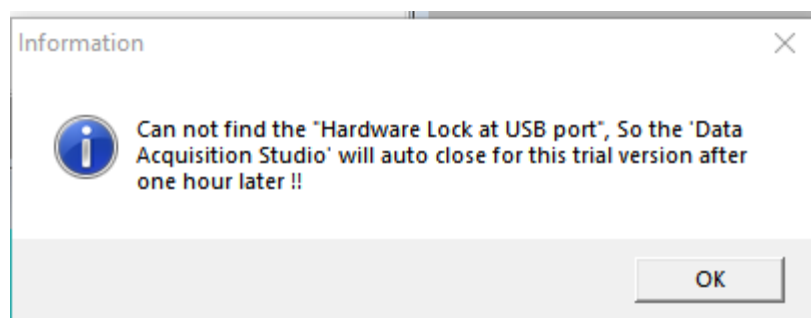

- Press OK to start in demo mode.

- If the USB Licence key is plugged in to the USB port of the PC then the software will start reading the data from the devices and log the data to the PC.

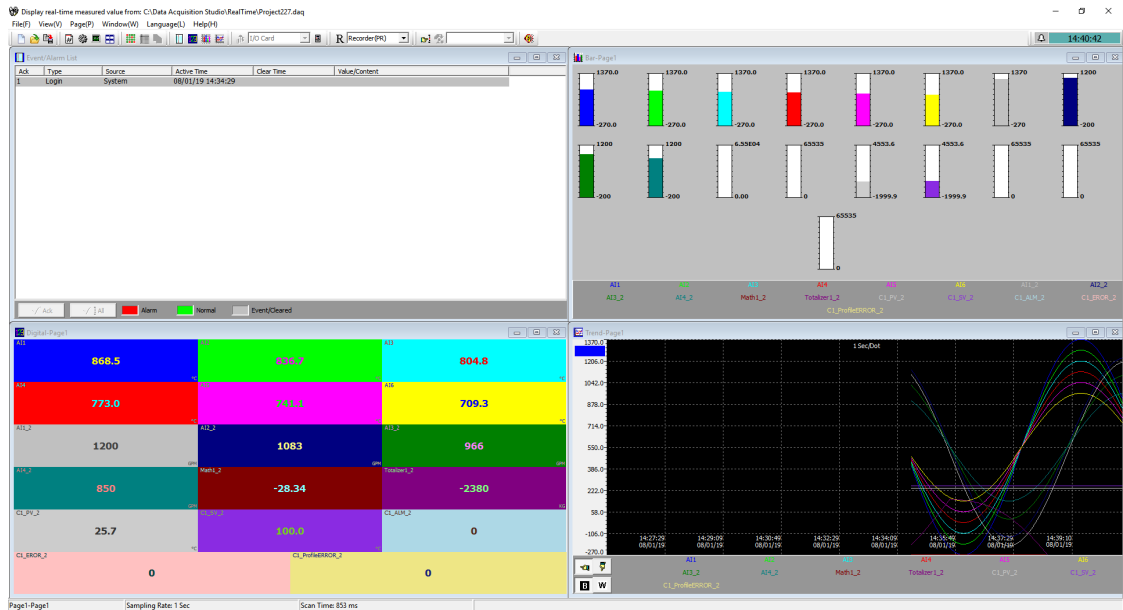

6.2.4 Dynamic Data Exchange (DDE)

Dynamic Data Exchange (DDE) is a standard inter-application communication protocol built into Microsoft Windows operating systems and supported by many applications that run under Windows. DDE takes data from one application and gives it to another application. It allows Windows programs that support DDE to exchange data between themselves.

Data from DAQ software can be exchanged with Excel on DDE link. After completion of all network configuration (adding of all Modbus slaves), then open Data acquisition studio software – Real-time viewer. Open the existing project or create a project then go to File Menu in Real time Viewer then select Create DDE Link in Excel.

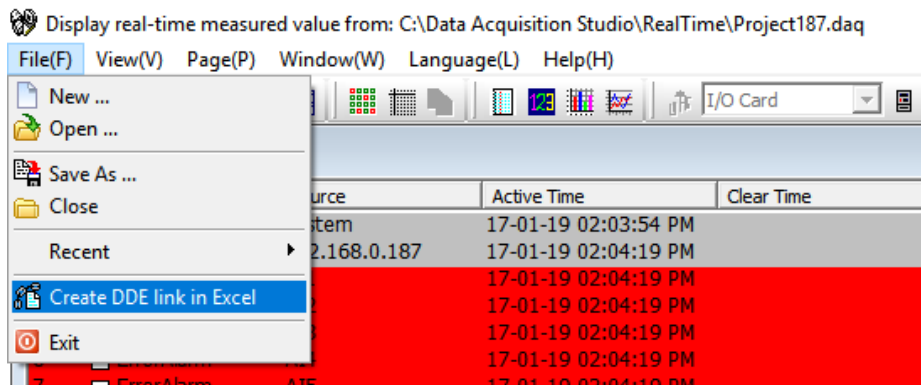

Specify the path and file name as follows. By default the file name will start with DDE and the project name with underscore. Save the file name in PC at selected path as above to proceed further.

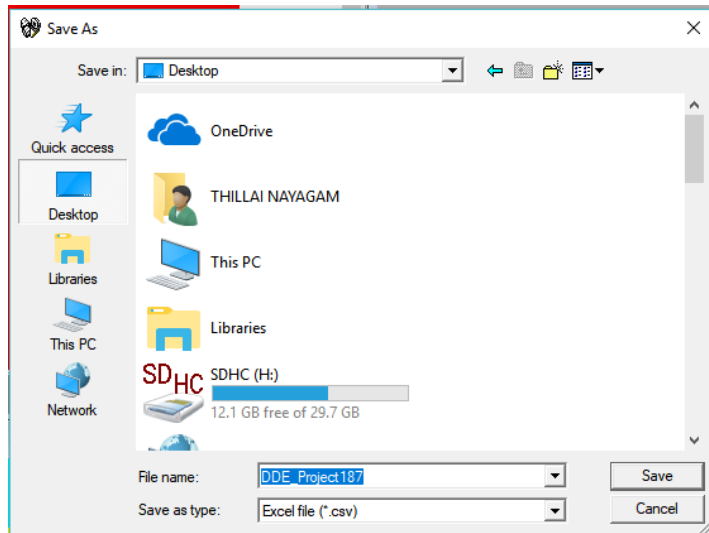

For example, if Desktop is selected in the path, then Excel file should be available in Desktop. If the MS Office is not installed in the PC, then you cannot open the Excel file created in the above procedure. Please contact your system administrator to install MS office software in the PC. Now try to open the file from Desktop created for using DDEapplication with the recorder through Real-time viewer Software.

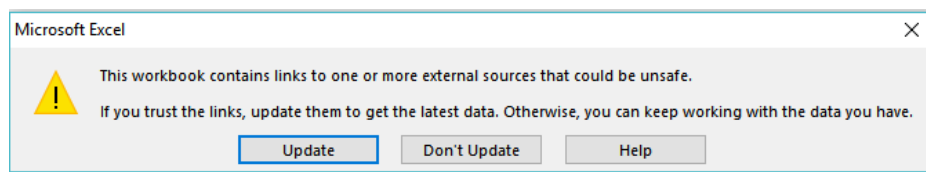

Click on update to activate DDE between DAQ software and Excel application. If the DDE is successful, then real time data of the channels should be updated in Excel file as shown in sample screen.

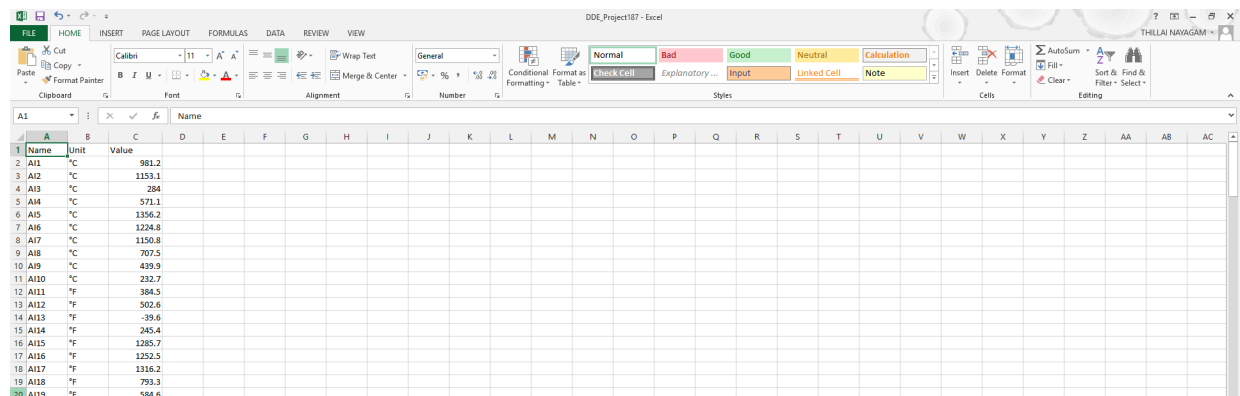

DDE expression format to get real time data from the Real time Viewer software is as follows.

=RealTime_Viewer|TagService!_TagN

Where N = 1,2,3.....

Application = RealTime_Viewer

Topic = Tag Service

Tag name = _Tag1 (Please observe underscore before the tag number)

It is possible to exchange data related to AI, DI, DO, Counters and Totalizers between DAQ software and third party applications running under windows operating systems via DDE.

6.2.4.1 Procedure to find the tag number for the tag name to use in DDE applications

- ❖ Create DDE link from Real time viewer.
- ❖ Open Excel file. Three columns appear in the Excel file as Name, Unit and Value as shown in the Excel file.
 - **Name:** This is tag name actually defined in the channel configuration
 - **Unit:** This is unit for the tag name defined in the channel configuration
 - **Value:** This is the specific cell where, process value for the tag will appear in real time.
- ❖ To find the DDE format for any tag in channel configuration, for a specific tag, double click at "Value" column for the corresponding tag defined at Name. For ex: For Name= AI1 is at R2C1, double click at cell R2C3 to see DDE format for AI1. Click on Esc button at the key board to see process value at the cell from displaying DDE format.

	A	B	C	D	E	F	G
1	Name	Unit	Value				
2	AI1	°C	-194.5				
3	AI2	°C	-181.7				
4	AI3	°C	-200.7				
5	AI4	°C	-106.3				
15	AI14	°F	453				
16	AI15	°F	1588.4				
17	AI16	°F	1503.4				
18	AI17	°F	1516.9				
19	AI18	°F	923.8				
20	AI19	°F	645.6				
21	AI20	°F	386				
22	AI21	°C	-60				
23	AI22	°F	-32.8				
24	AI23	%	20				
25	AI24	%	30				

- ❖ If any "Error" appears in any cell at Excel, possible reasons is no data available at selected tag. Check the channel configuration and make sure value is available.
- ❖ If any "NAME" text appears in the Excel file, it indicates that particular tag is not configured properly. Tag name may not available at DAQ software.

Note:

If Excel file is not opening from the selected path, then check the following:

- ✓ RAM size in the PC is very less. Restart the computer and then create the DDE link once again and open the Excel file.
- ✓ Increase virtual memory in the PC. Please contact system administrator to check the virtual memory settings at the PC.
My computer-properties-advanced-performance settings –advanced virtual memory.

6.2.4.2 DDE with 3rdparty applications

Once the data is available at Excel at particular cell, then data can be exchanged with the 3rd party applications like PLC, SCADA, and Visual Basic etc. If data is to be exchanged with PLC, then PLC programmer can write Visual basic macro in Excel from the following link

Excel – Tools – macro

For the source code examples, PLC programmer may check the PLC manuals for DDE sample macros. It is also possible to exchange data from recorder to SCADA applications through DDE.

6.2.5 Configuration of Recorder

There are three ways to configure the recorder. They are listed as below.

1. On the Recorder
2. Software via Ethernet port
3. Removable media

6.2.5.1 On the Recorder

It is possible to configure the recorder directly on the device using the touch screen interface. Press  (**Menu**), then **More** and then **Config** soft key to enter Configuration mode. The user can directly configure all the parameters on this page. Refer [chapter 5](#) for more details.

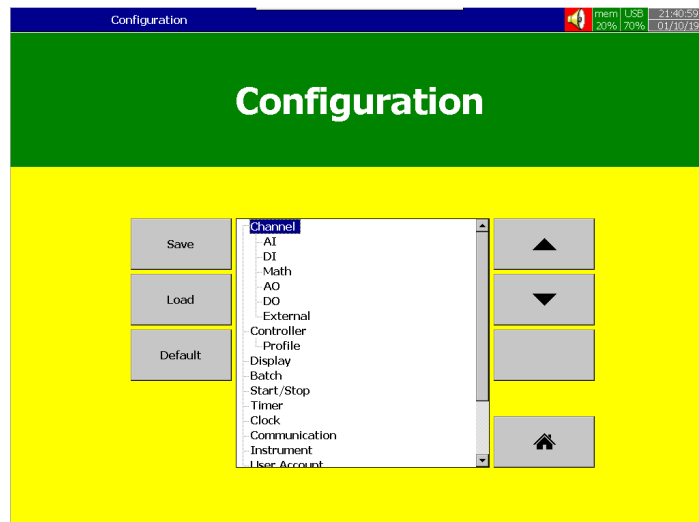

6.2.5.2 Software via Ethernet port

The below steps to be followed to configure via software using Ethernet port of the recorder.

1. Connect Recorder to PC via cross over or straight Ethernet cable
2. Check IP address of PC. Make sure to set IP address of Recorder in the same domain as PC

For ex: IP address of PC: 192.168.0.200

IP address of Recorder: 192.168.0.11

3. Use "Ping" from DOS command prompt and check the communication quality. If there is no response, check the cable or IP address configuration of PC or IP address configuration of the recorder

```
Microsoft Windows [Version 10.0.17134.523]
(c) 2018 Microsoft Corporation. All rights reserved.

C:\Users\thill>ping 192.168.0.187

Pinging 192.168.0.187 with 32 bytes of data:
Reply from 192.168.0.187: bytes=32 time<1ms TTL=128
Reply from 192.168.0.187: bytes=32 time<1ms TTL=128
Reply from 192.168.0.187: bytes=32 time<1ms TTL=128
Reply from 192.168.0.187: bytes=32 time<1ms TTL=128

Ping statistics for 192.168.0.187:
    Packets: Sent = 4, Received = 4, Lost = 0 (0% loss),
    Approximate round trip times in milli-seconds:
        Minimum = 0ms, Maximum = 0ms, Average = 0ms

C:\Users\thill>
```

4. Double click the historical viewer icon at desktop and follow on-screen instructions to create a new project.

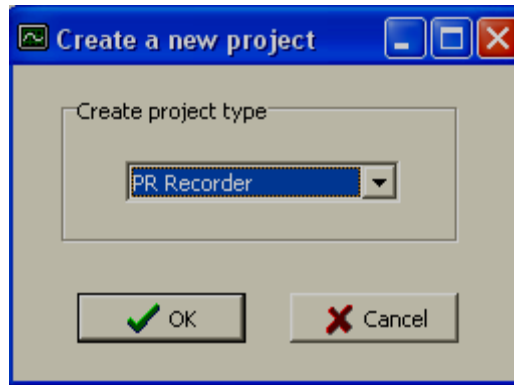

5. Click the icon  or select New from File Menu.
6. The software will prompt the user to select the device type. Select Recorder (PR) and click ok to create a new project.

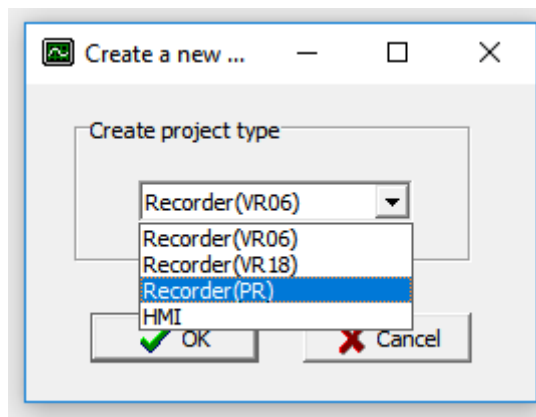

7. The Software will prompt the user to configure the project name and the path for the recorder.

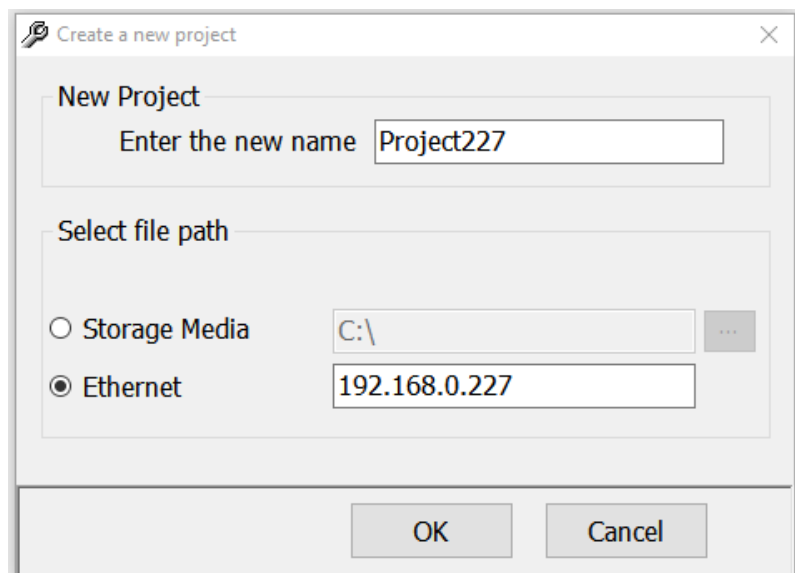

8. Click "OK".

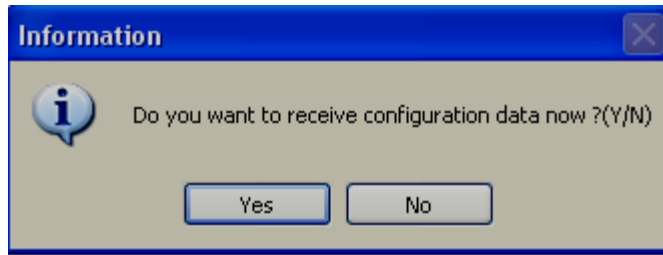

9. Click “Yes”. It will open Recorder configuration screen

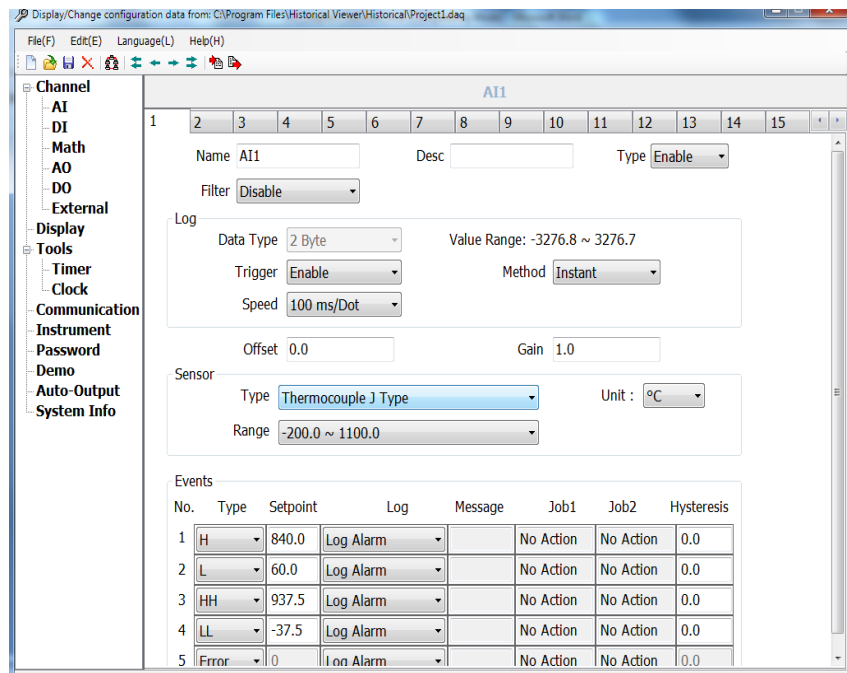

Note: The configuration screen is the same as the screen available directly in recorder. Refer [chapter 5](#) for more details.

10. Do the required changes in the configuration. Click at Send configuration icon 

11.

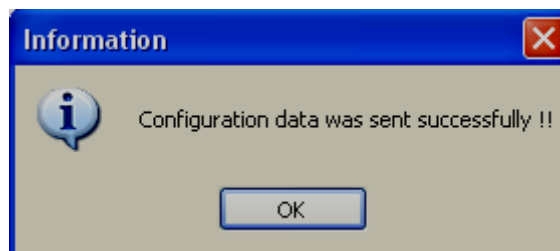

12. Now the recorder configuration has been updated with the new configuration.

6.2.5.3 Removable Media

The recorder can be configured via removable media by following the steps given below.

1. In recorder, insert an empty SD card or USB disk.
2. In the recorder, Press  (**Menu**), then **More** and then **Config** soft key to enter Configuration mode. In the configuration menu press **Save** to save the configuration to the removable media. The removable media can be selected by external storage option in the Instrument menu. The default selection for external storage is SD Card.

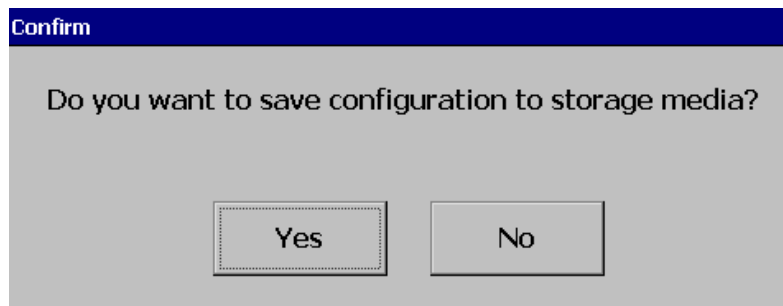
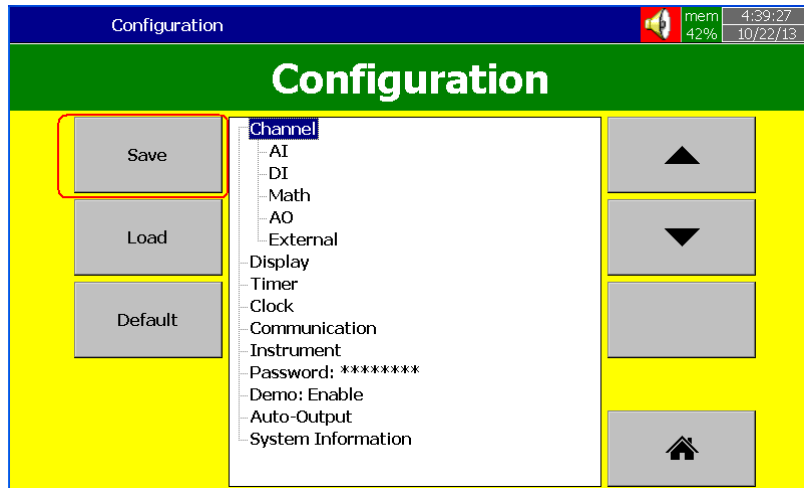

3. Press "Yes" to save the configuration to storage media.
4. Remove the removable media from the recorder. Insert into PC
5. Check contents of storage media. It should have the following files.

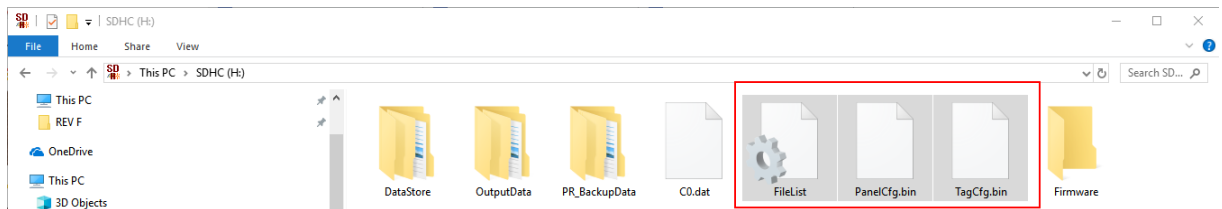

6. Double click the historical viewer icon  at desktop and follow on-screen instructions to create a new project.

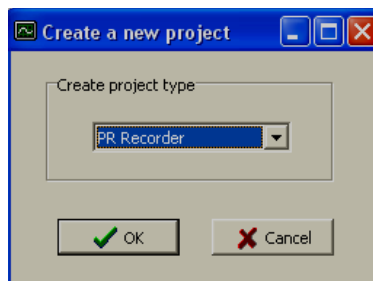

7. Select PR Recorder. Click "OK"

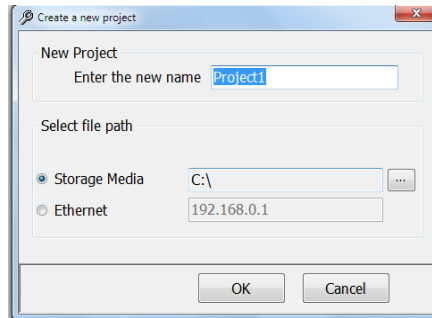

8. Select “Storage Media”. Then enter the path to the Recorder files in USB stick or SD card. Click “OK”

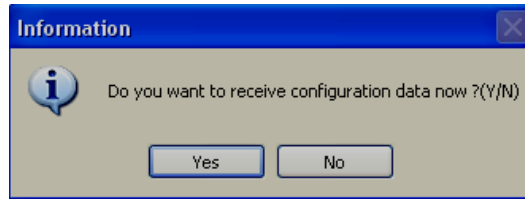

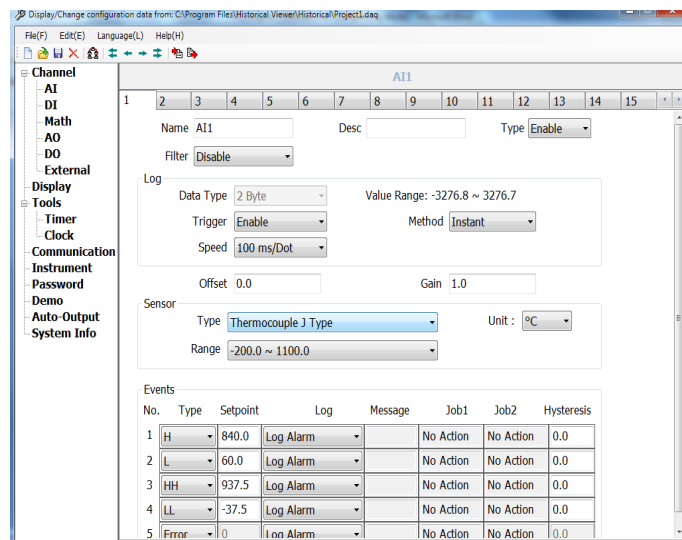

9. Click “Yes”. It will open Recorder configuration screen

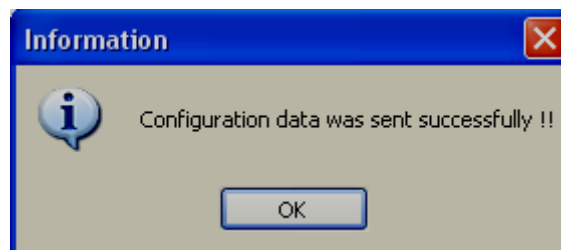

Note: The configuration screen is the same as the screen available directly in recorder. Refer [chapter 5](#) for more details.

10. Do the required changes in the configuration. Click at Send configuration icon 
- 11.



12. In the recorder, Press  (Menu), then More and then Config soft key to enter Configuration mode. In the configuration menu Press “Load”

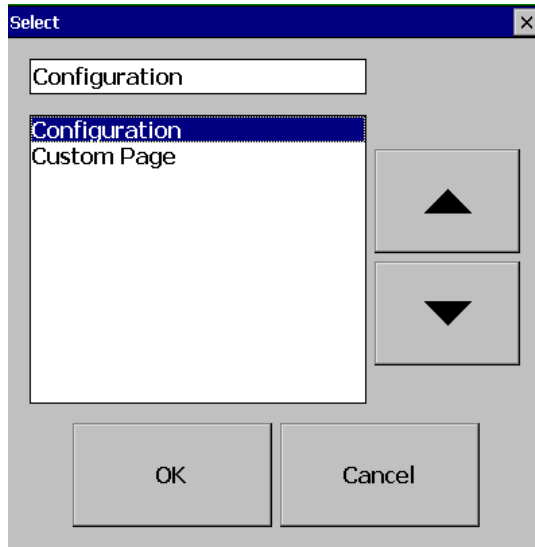
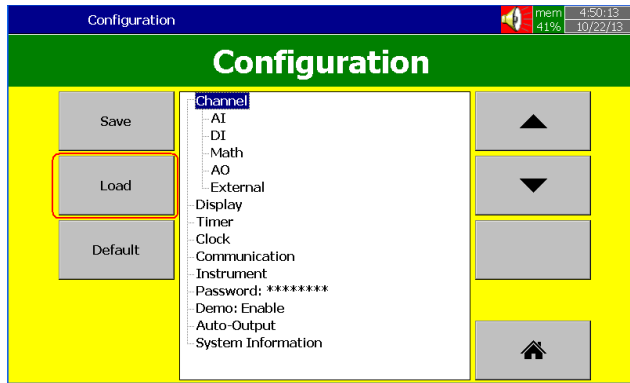

13. Press "OK"

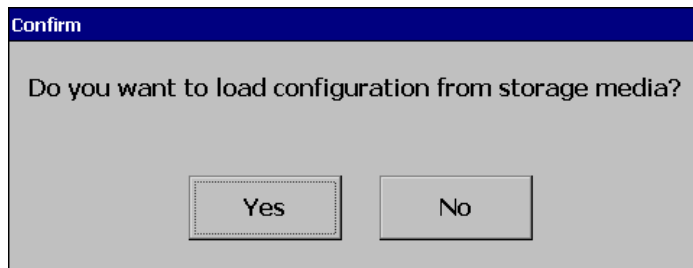

14. Press "Yes"

15. Now the recorder configuration has been updated with the new configuration.

6.3 Custom Screen Editing Software - Panel Studio

Using this software the user can develop custom screens for custom display same as HMI and SCADA. All the graphics developed on the screens can also be configured for animations.

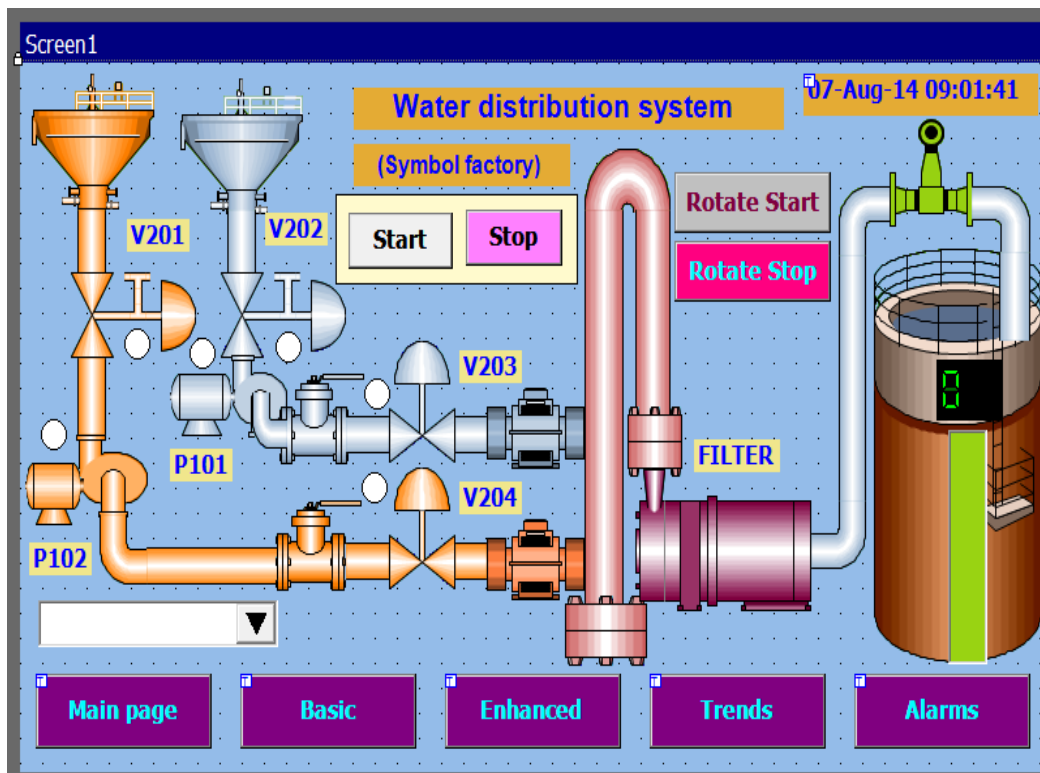
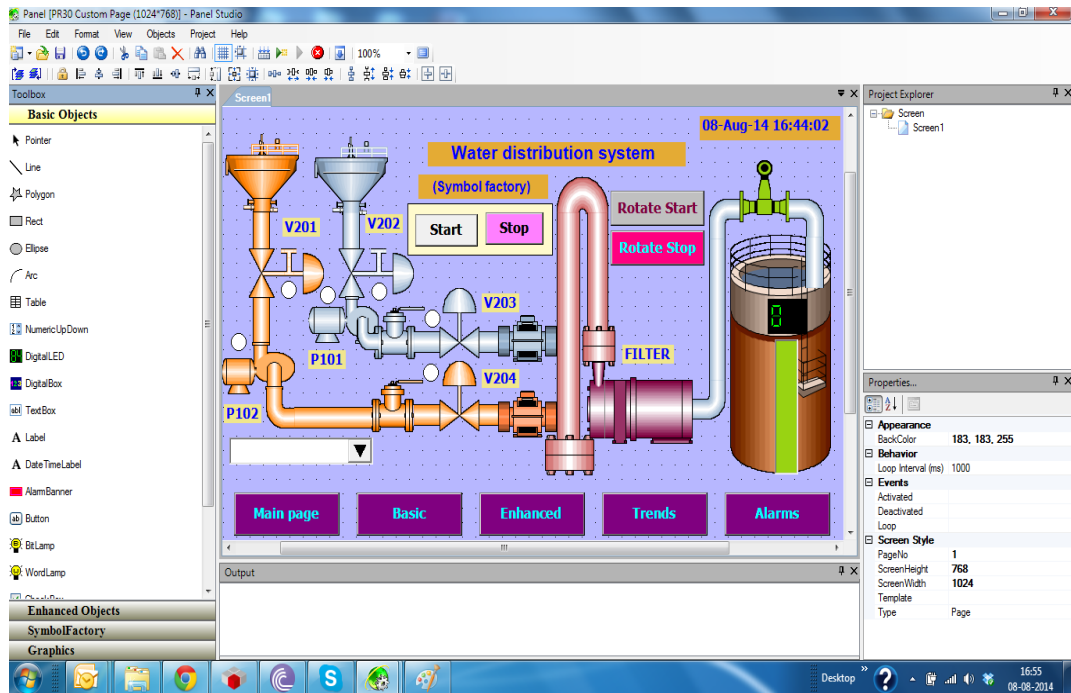

Use this editing software to develop custom screens on the Recorder. It is mainly used for application development for operator interface in industrial applications such as display real time value of process parameters like temperature, flow, pressure, visualize process data in meaningful ways such as bar graphs, dial, meter, level, digital LED, animation like visibility control, blinking, horizontal movement, vertical movement etc.

6.3.1 Panel Studio Software Installation

The panel studio Software will install the following components on the PC.

- Microsoft installer V3.1
- Microsoft.Net frame work V3.5 SP1
- Panel Studio Custom Screen Editing Software
- OPC server (Only Required for HMI)
- Demo projects (Only Required for HMI)
- Historical viewer
- HMI Remote viewer (Only Required for HMI)

6.3.1.1 System Requirements

Item	Minimum Requirements
System	IBM PC compatible computer with Intel Pentium IV or above
Operating System	Windows XP or above
Memory	1 GB
Hard Disk	50 GB Free Space on the hard disk
Communication Ports	Ethernet Port
Others	USB Port
Licence	Optional USB Licence Key for Symbol Factory

6.3.1.2 Software Installation

The Panel Studio software can be installed by following the below procedure.

1. Download the Panel Studio software form the manufacturer's website.
2. Install latest dot Net software from Microsoft website
3. Install the software by double clicking the setupwizard.exe from Panel Studio folder.

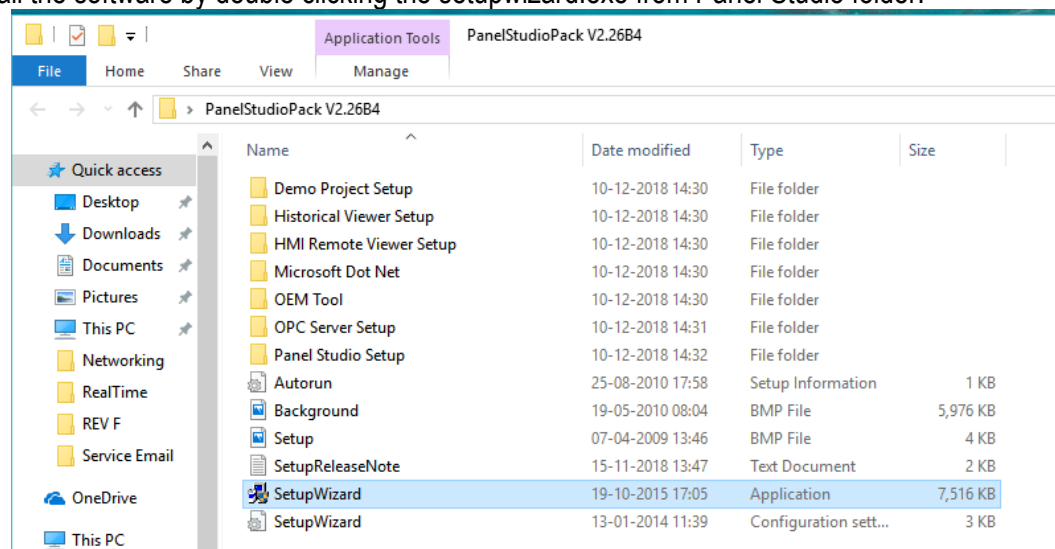

4. Select the required Software needs to be installed on the PC and press Install key to continue installation.

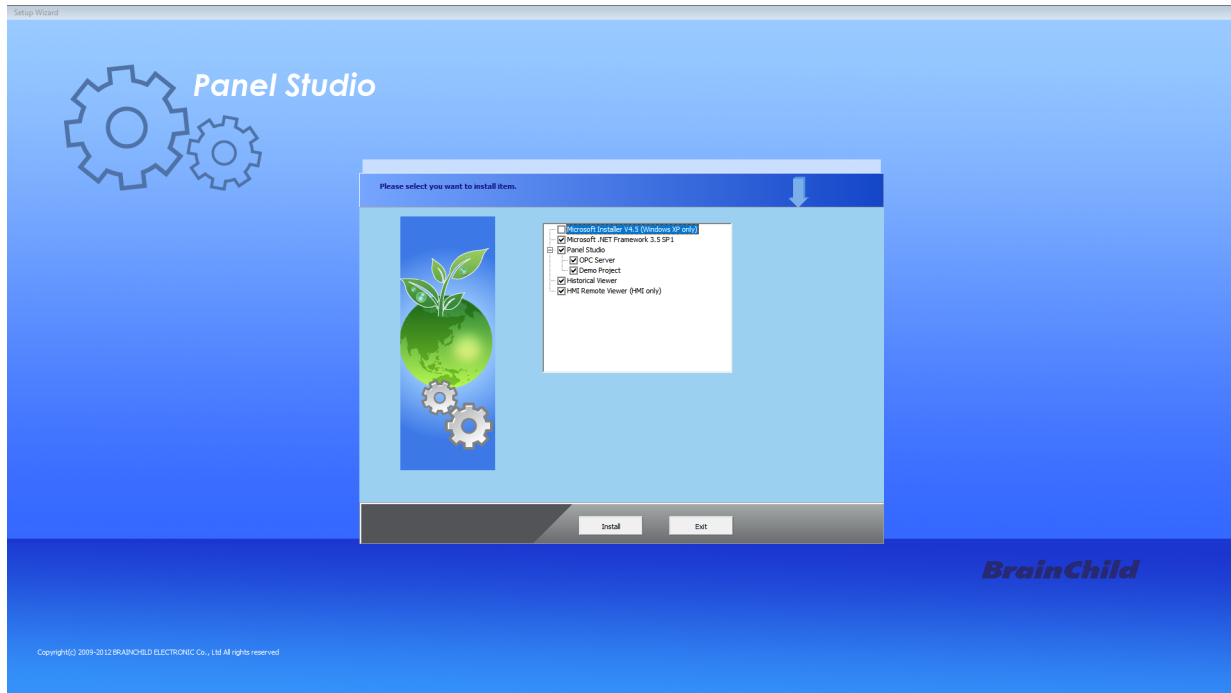

5. Follow onscreen instructions to complete the installation. Once the installation is completed the system will show the installation complete message.

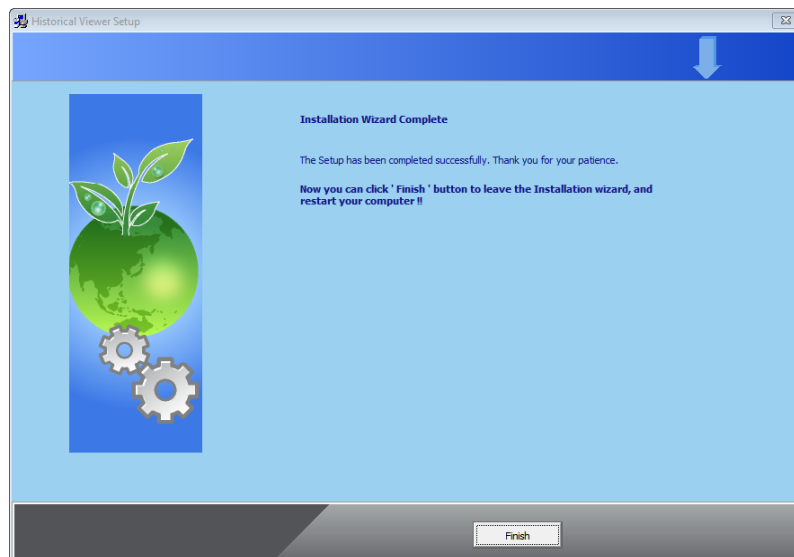

6. After installation is successful, shortcut for Panel Studio, Historical Viewer and HMI Remote Viewer will be created on the desktop.

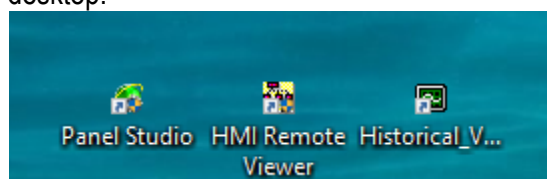

6.3.1.3 Uninstallation of Software

The software can be uninstalled by selecting the uninstall option on the control panel Add or Remove Programs.

6.3.2 Start and Exit

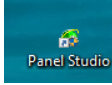
The Panel Studio program can be start by using the shortcut  on the desktop or selecting the program Panel Studio from the start menu.

The program can be exit by simply closing the program X symbol on the top right corner of the screen.

6.3.3 Project status

During design time, it is possible to check current status of resources being used

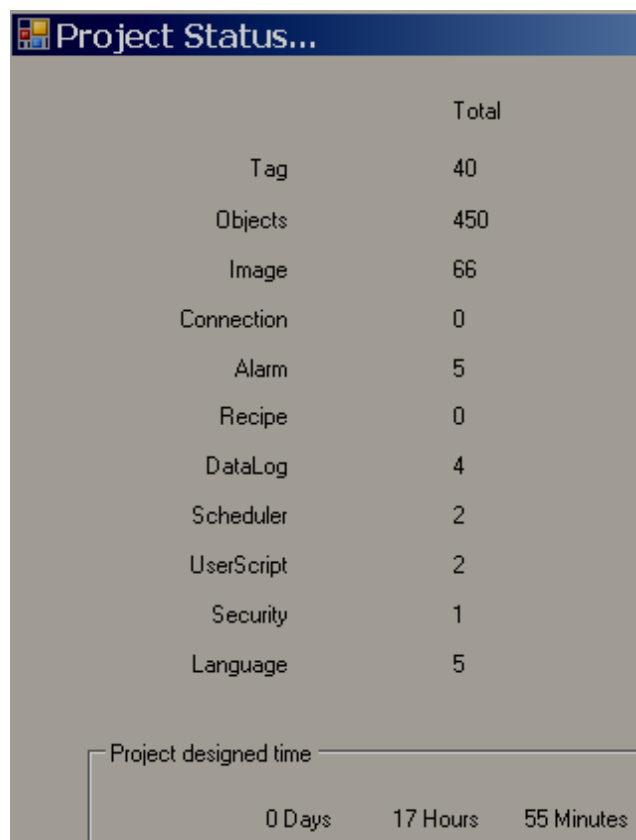
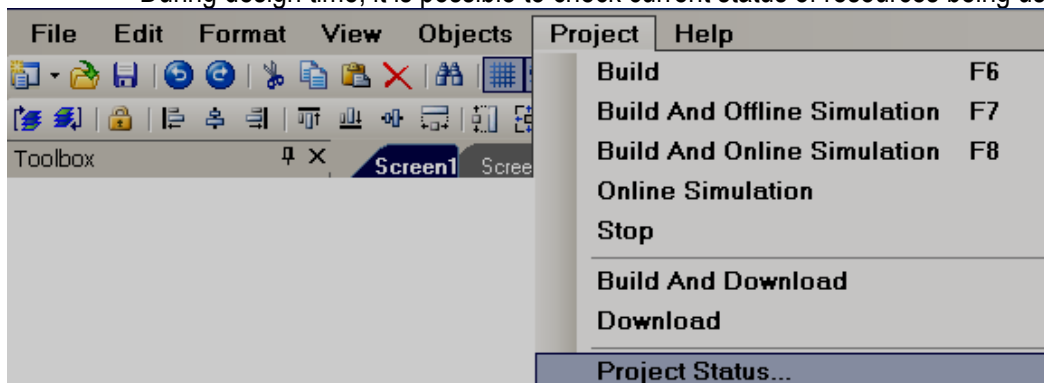

A screenshot of the 'Project Status...' dialog box. It displays a table of resource counts and a section for 'Project designed time'.

	Total
Tag	40
Objects	450
Image	66
Connection	0
Alarm	5
Recipe	0
DataLog	4
Scheduler	2
UserScript	2
Security	1
Language	5

Project designed time
0 Days 17 Hours 55 Minutes

“Image” means symbols used from graphics and symbol factory. These symbols are also considered objects, so, if you add symbols, it also updates quantity in objects.

For example, if user add 2 symbols and one rectangle object. Then, Images = 2, Objects = 3

6.3.4 Create new project

Open Panel Studio Software and select create a new project to create a new project.

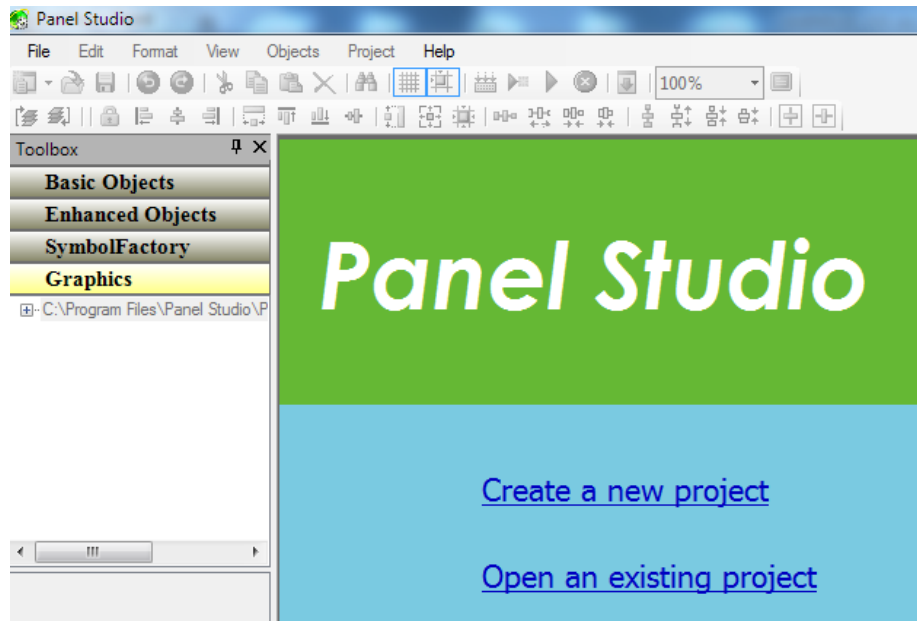

Name Location ...

Model v

Width Height

Author Version

Password ...

Comment

OK Cancel

Name: It is Name of the Project. For ex: Custom Screen_PR

Location: It is path for project file storage.

Model: Select the Recorder Model No from the list. For ex: PPS-2000

Width: It is pixels, resolution in dots available on X-axis

Height: It is pixels, resolution in dots available on Y-axis

Author: Write author name/system integrator name for future reference

Version: It is for version management

Password: It is for user security of the project. The Project can be protected by assigning a password to open the project.

Comments: It is for project management

After entering all the above details, click “OK” to create a new project.

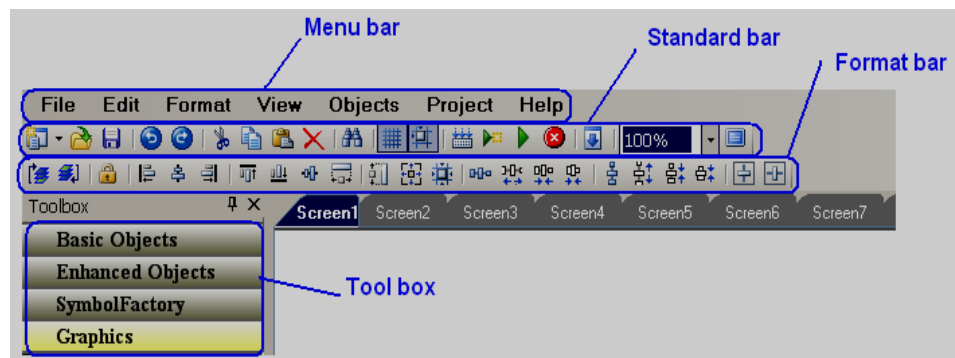
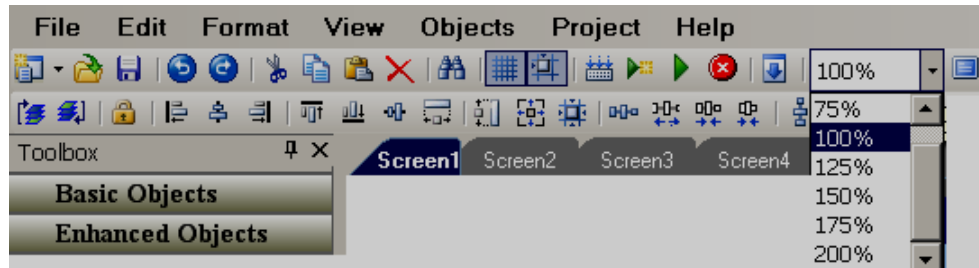

6.3.5 Menu bar

The menu bar has below menus.

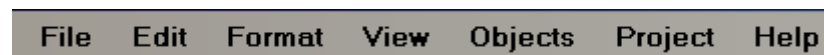

6.3.5.1 File

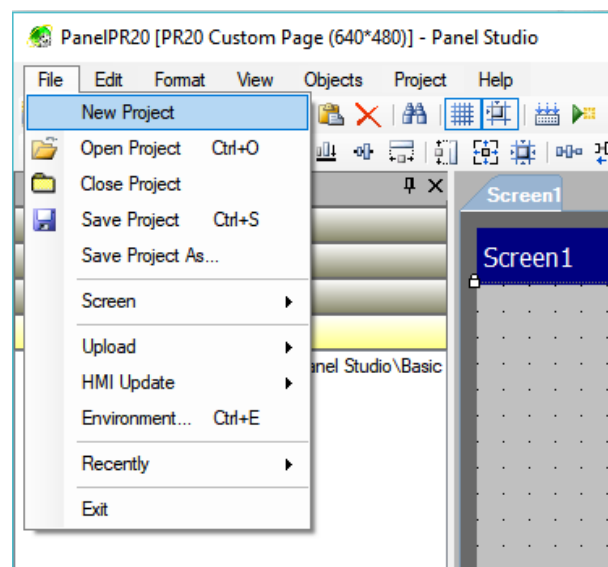

1. **New Project:** To create a new project
2. **Open Project:** To open existing project

3. **Close Project:** To close present project
4. **Save Project:** To save Project in default path
5. **Save Project As:** Saves project in selected path other than default path specified while creating a new project settings.
6. **Screen:** Create a new screen on the project.
7. **Upload:** To upload project from Recorder back to PC
8. **HMI Update:** This function will allow the user to update the clock, firmware, language on the HMI. This function is available only for HMI.
9. **Environment:** This will allow the user to modify the project environment configurations.
10. **Recently:** It is to open recently opened projects
11. **Exit:** To exit from current project

6.3.5.1.1 Environment

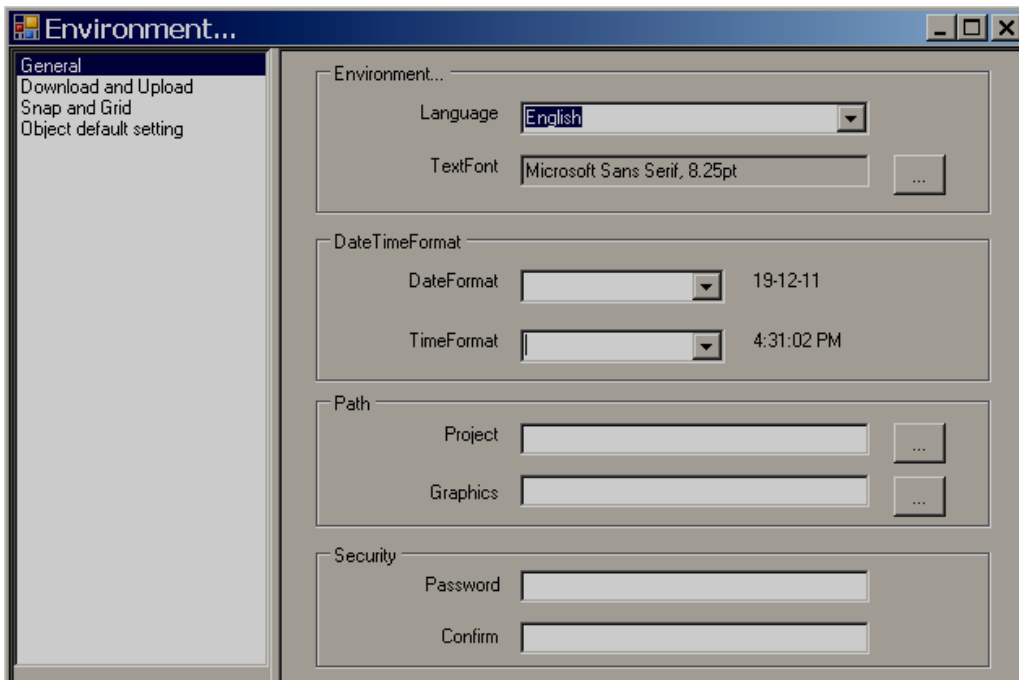

6.3.5.1.1.1 General

1. **Language:** Select the Language for project environment. 20 languages are supported by Panel Studio Software including English, Simplified Chinese, Traditional Chinese, Japanese, French, German, Italian, Polish, Spanish, Portuguese, Brazil Portuguese, Russian, Thai, Czech, Danish, Dutch, Korean, Swedish, Turkish and Greek.
2. **Environment font:** Select font required for design time environment. Example: Menu, Tool Box, Project explorer, function editor etc.
3. **Project Path:** Location to storage of project files. Default project path: C:\Program Files\Panel Studio\Demo Project
4. **Graphic Path:** Location of default basic Symbols. Default graphic path: C:\Program Files\Panel Studio\Panel Studio\Basic Symbols
5. **Security:** This is to protect opening the software in specific Personal computer (Not for project). Once password is entered, it is required to enter password correctly to open the software for the current session. This is useful in factory environment to prevent un-authorized users to open the software.

Note: If user need a password for a specific project, click “Settings” in the project explorer, select “General” tab, and then enter the Password.

 In general, it is preferred to back up project files regularly in other standard storage media like CD, DVD etc. It is recommended to store project files in separate folders on the D: drive instead of C: drive. Developers may make a hard disk partition and save all project files in drives other than location of operating system in the event that if there are problems with Operating system, it is still possible to retrieve project files.

6.3.5.1.2 Download and Upload

Please refer to section “Project tools” for more detailed information.

6.3.5.1.3 Snap and Grid

Used to define grid behaviour in the design time environment.

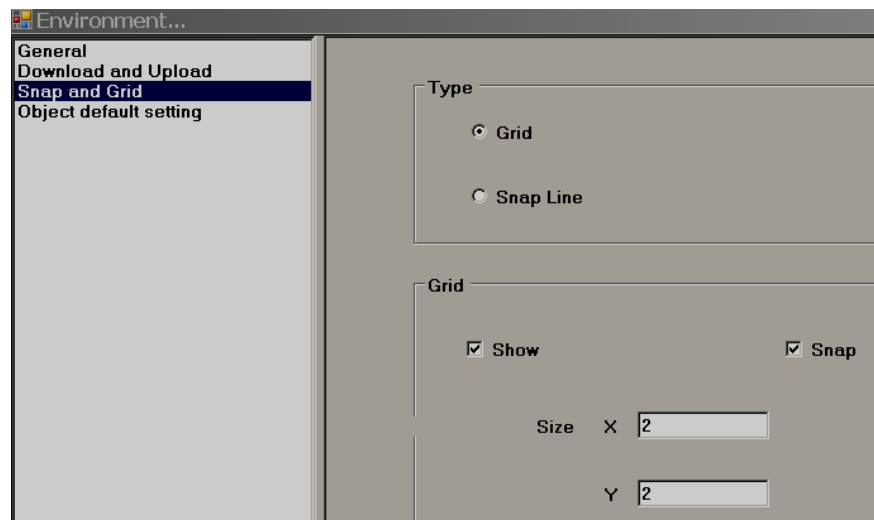

1. **Grid:** Select this option and select “Show grid” if grids are to be appeared in screen at design time.
2. **Snap lines:** Select this option if grids are not required to appear in screen at design time.
3. **Snap:** Select this option if component coordinates should within grids all the time.

6.3.5.1.4 Object default setting

Define default font size, Fill color, Back color and Fore color for the properties of most of the objects (label, Check box, Rectangle, Ellipse, Pie, Table, Dial, Level, Meter, Slider, Thermometer etc.).

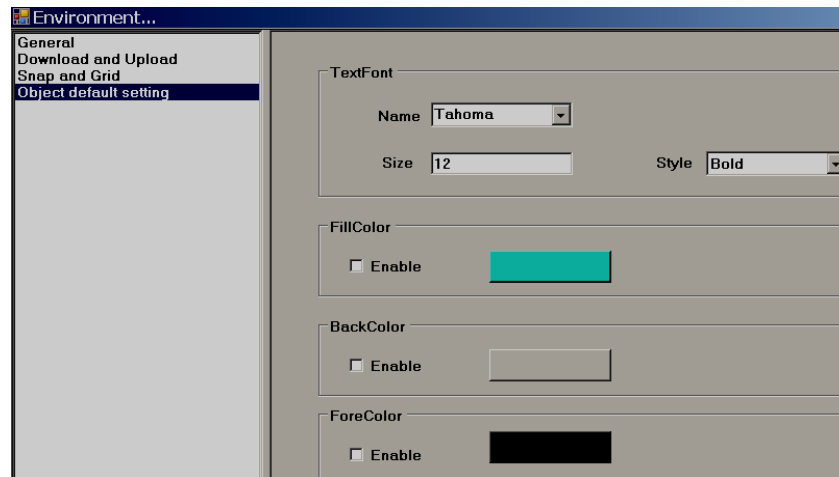

6.3.5.2 Edit

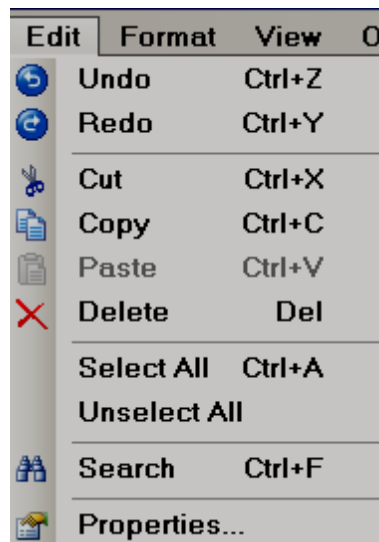

6.3.5.3 Format

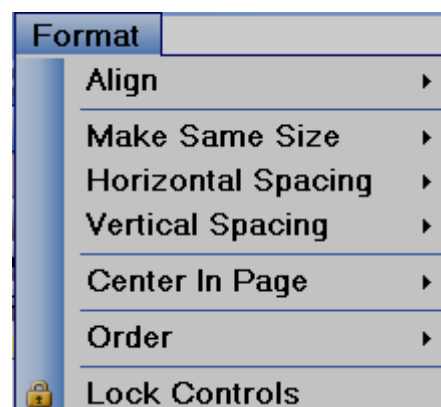

- 1. Align:** Used to align selected components, objects etc. for adjusting their position precisely in the screen layout. Available options for selection are Center, Right, Left, Top, middle & Bottom.
Example: Align two Labels to the left in Recorder screen.

Assume both labels are created in Screen1. Select both labels first using mouse. Alternatively, select first label by left clicking the mouse, then press "Ctrl" on the keyboard and select the second label by left clicking the mouse. Now, in Menu, click "**Format**", then select "**Align**", then select "**Left**".

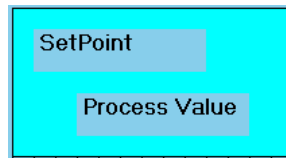

Before Align adjustment

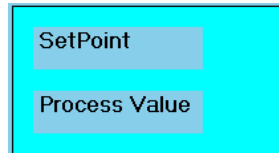

After Left Align adjustment

2. Make Same Size: To adjust different objects to the same Width, Height, Both width and height, Size to grid etc.

Example: Adjust five buttons to same size i.e., height and width.

Create five buttons first. Then, select all these buttons via Mouse, then click “**Format**”, then select “**Make same size**”, then select “**Both**”

Before size adjustment



After Same Size adjustment

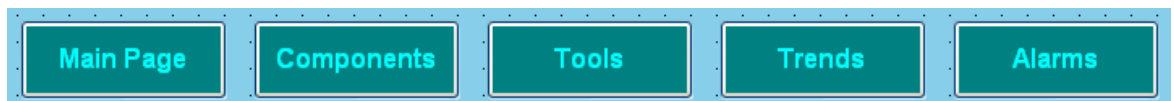

3. Horizontal spacing: It allows adjustment of horizontal spacing between any objects to make Equal/Increase/Decrease/Remove.

For example: There are 3 buttons located at bottom area of a page. Spaces between these buttons are not equal and screen does not looking good. Select all the 3 buttons via Mouse or using “**Ctrl**” on the keyboard along with mouse. Then in Menu bar, click “**Format**”, then select “**Horizontal spacing**”, then select “**Make equal**”. Now, space between all these buttons with have an equal distance.

Before Spacing adjustment



After Horizontal spacing adjustment



4. **Vertical spacing:** It allows adjustment of vertical spacing between any objects to make Equal/Increase/Decrease/Remove

Before Spacing adjustment

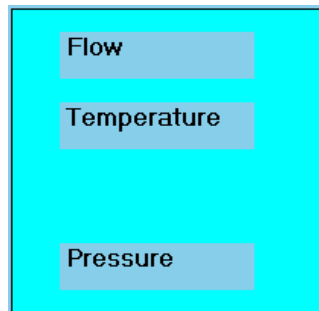

After vertical spacing adjustment

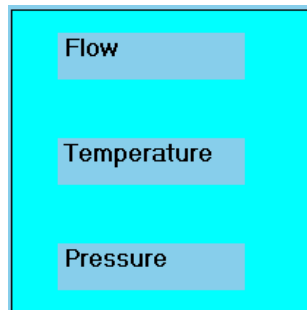

5. **Center in Page:** It allows adjustment of objects to center of the page horizontally and vertically
For ex: There are 3 buttons located at screen. You wish to locate them in the center of the page horizontally. Select these buttons and apply this feature to adjust buttons as per requirement.

Before Center adjustment



AfterCenter adjustment

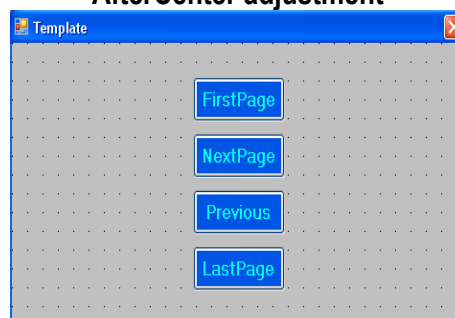

6. **Order**

- ❖ **Bring to back:** Moves objects to the back

❖ **Bring to Front:** Moves objects to the front

For example: There is Rectangle box and a label with different colors. If you wish to keep label text in front of the Rectangle, select the Rectangle, choose the option, “Bring to Back” and for the label, choose the option “Bring to Front”, such that both are visible at same time allowing overlapping of two objects for clear display.

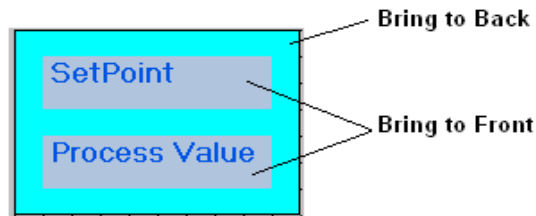

7. Lock Controls: It is to lock control for further development. Apply this for a second time to unlock the control.

6.3.5.4 View

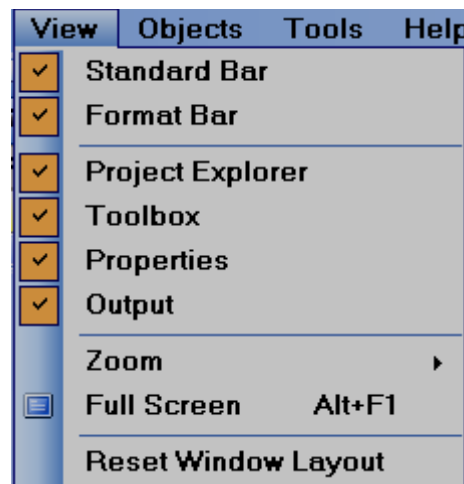

Select the required items to view in window layout.

1. Properties

If “properties” is checked as shown above, in the right side bottom of screen layout, the properties box will appear showing all the properties for the component/object that is selected.

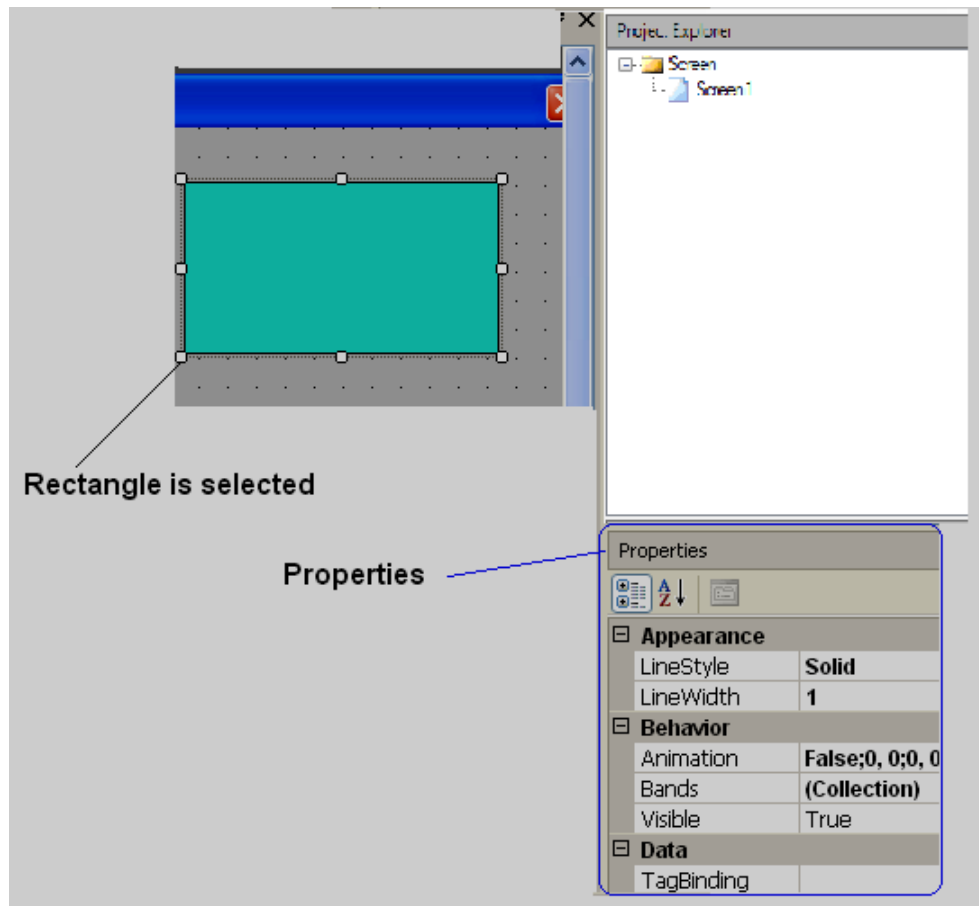

In above example, a rectangle is drawn, and once it is selected, the right side bottom corner will show all the properties for this specific rectangle if “properties” is checked in the View drop-down menu. It is possible to modify properties of the rectangle from property grid. Alternatively, if you double click on the rectangle, you will see a pop-up window where you can edit properties.

2. Output

If output is selected in the view drop-down menu, this window appears just below the screen working area. This window will display any errors that appear during compilation of project.

In Menu, click “Tools”, then “Build”, or alternatively, on the “standard” bar, click the icon  to prepare the build for the application. The project will then compile. A summary is shown in the output window as shown below.

```

Output
Screens preparing...
Check automatic of scan....
Screen1 images 0 / 0 objects 1 / 1
Conversion checking...
UserScripts checking...
Objects checking...
Alarms checking...
Scheduler checking...
Datalogs checking...
Recipes checking...
Build started....
Build succeeded.

```

3. Zoom

It is used to Zoom the current screen to various %, and it is useful during screen editing, particularly if screen size of PC screen is small. If 200% is used and if PC screen size is small, then horizontal and vertical slider will appear automatically in screen to navigate to other areas of screen easily.

4. Full screen

It is to display full screen. After selection, the screen layout will be as shown below. To go back, in menu, click at “View” and then “Full screen” again.

5. Reset window layout

Used to display the default screen layout showing the screen working area, tool box, project explorer, output window etc.



Ex: If user deselects the “project explorer” in the View drop-down menu, then it will not show the Project explorer at the right side of the window layout. In this case, the user may select Project explorer again in the View drop-down menu. Alternatively, in Menu, click “View”, then “Reset Window Layout”, then it will reset all the view selections and show default window layout.

6.3.5.5 Objects

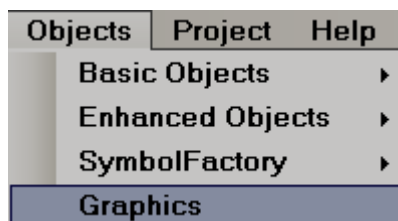

More details about Basic objects, Enhanced objects, Symbol factory and Graphics are explained in section “Tool Box”

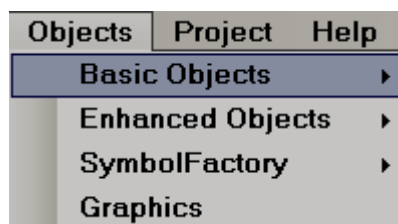

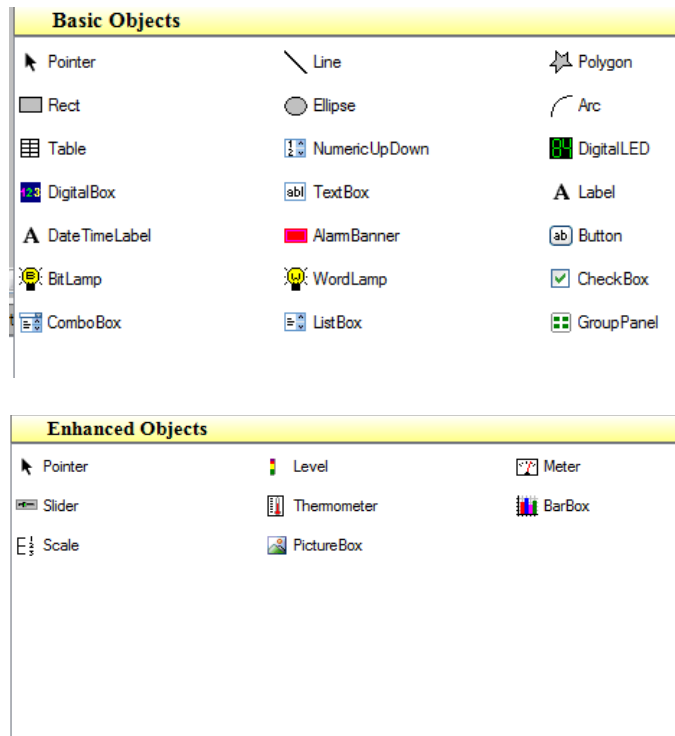

If you would like to increase font size in Menu bar, then, in menu, click File, then click “Environment” and then set font settings.

6.3.5.6 Project

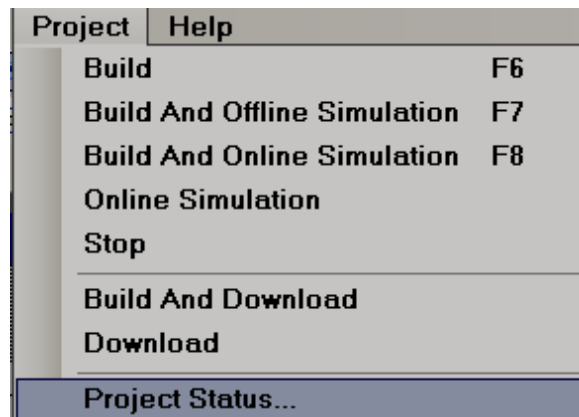

















Above details are explained at section “Project Tools”

6.3.6 Standard bar

The standard bar has below tools.



























- ✓  Open Project
- ✓  Save Project
- ✓  Undo
- ✓  Redo
- ✓  Cut
- ✓  Copy
- ✓  Paste
- ✓  Delete
- ✓  Search
- ✓  Show Grid
- ✓  Align to Grid
- ✓  Build
- ✓  Offline Simulator
- ✓  Online Simulator
- ✓  Stop simulation
- ✓  Download
- ✓ Zoom Size
- ✓  Full screen

6.3.7 Format bar

The Format bar has below tools.



- ✓  Bring to Front
- ✓  Bring to Back
- ✓  Lock the control
- ✓  Group
- ✓  Ungroup
- ✓  Align left
- ✓  Align center
- ✓  Align right
- ✓  Align Top
- ✓  Align bottom
- ✓  Align middle
- ✓  Make same width
- ✓  Make same height
- ✓  Make same size
- ✓  Size to grid

- ✓  Make horizontal spacing equal
- ✓  Increase horizontal spacing
- ✓  Decrease horizontal spacing
- ✓  Remove horizontal spacing
- ✓  Make vertical spacing equal
- ✓  Increase vertical spacing
- ✓  Decrease vertical spacing
- ✓  Remove vertical spacing
- ✓  Center vertically
- ✓  Center Horizontally

6.3.8 Project Explorer

The project explorer has the below options on the right side of the screen in software.

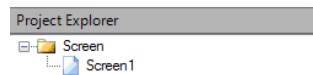

6.3.8.1 Screen

This is to add new screen to the project. It is possible to set screen into the following types

1. **Page**
2. **Template**
3. **Popup**

When a new project is created, screen1 (Page type) is created by default. It is not possible to change screen1 to either template or popup. Screen1 (start page) should be "Page" type only.

How to add a new page

In Project Explorer, select "Screen1", then right click your mouse. It will show the screen below. Click "Add", and Screen2 will be created and will appear as shown below.

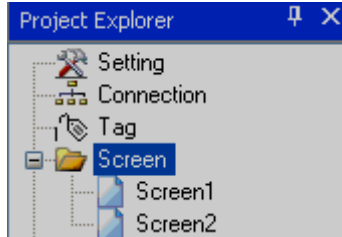
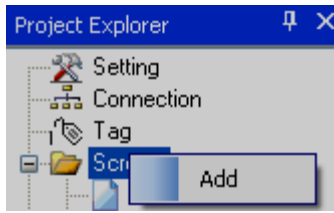

Now, Select Screen1, then check its properties. For example: It is possible to change the background color of a screen from the page properties

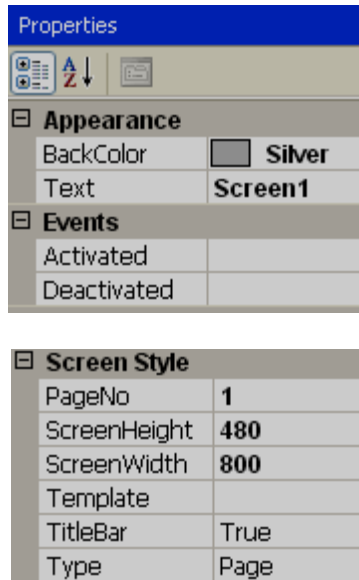

Right click mouse keeping the pointer on any page, then, user can edit screen properties via the wizard.



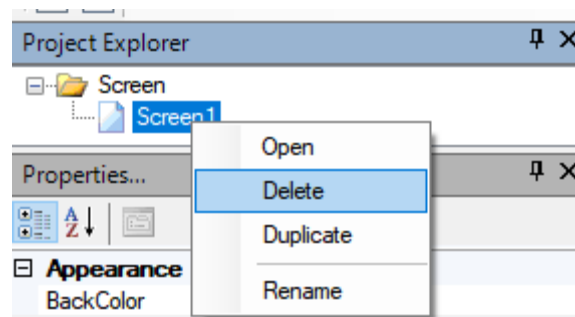
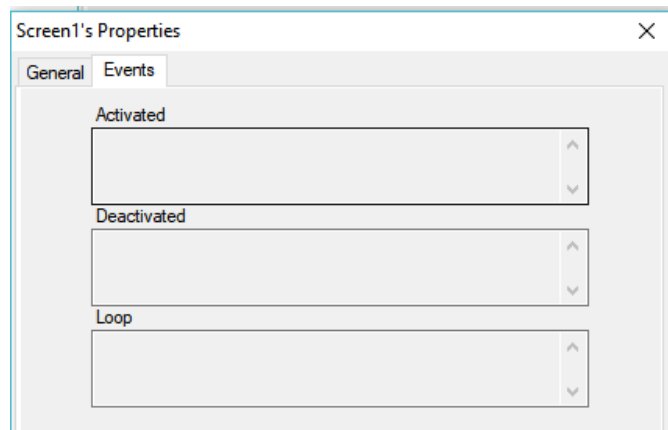
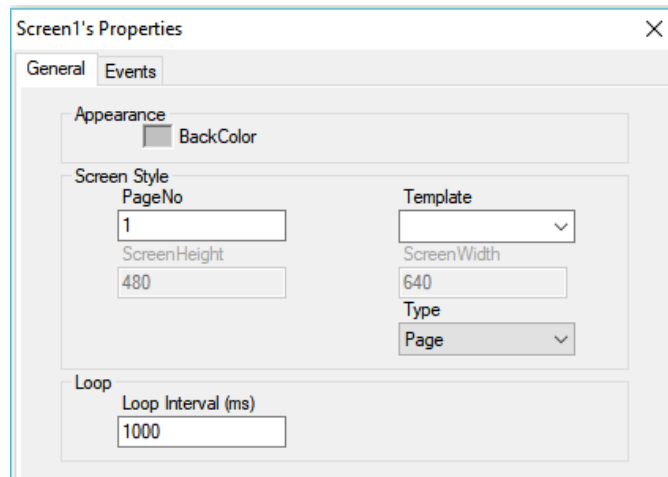

It is possible either to open, delete or rename a screen. Select the appropriate screen in the project explorer, then “Right click” the mouse to show the above Screen dialog.

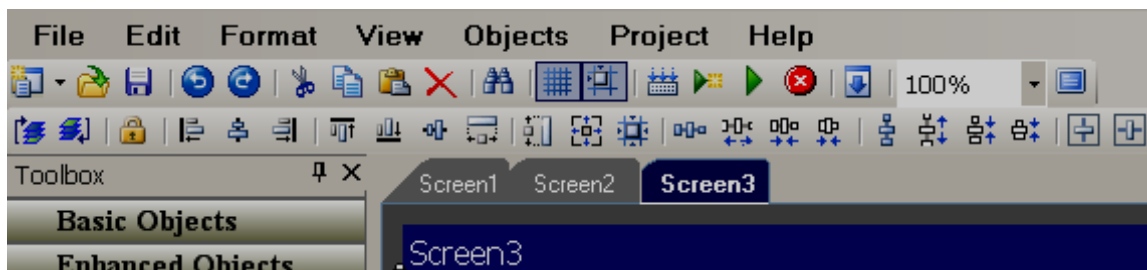

Note: These screen display names are the same as those available at project explorer. These are different from title bar (Text) defined for screen.

❖ **Properties**

Back Color: Defines the background color of a component.

❖ **Events**

Activated: Defines tasks to be executed before opening a Screen.

Deactivated: Defines tasks to be executed before closing a Screen.

❖ **Screen Style**

Page No: Displays current page number.

Screen Height: Defines/Displays current screen height.

Screen Width: Define/Display current screen width.

Template: Select the Template page for this screen.

Type: Defines the type of screen. Available options include Template, Page and Popup.

6.3.9 Tool box

These can be accessed from menu bar also from objects.

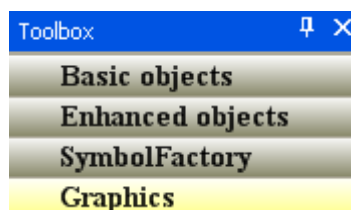

6.3.9.1 Basic Objects

It is to draw simple shapes in the screen, data entry, data display, alarms view etc.

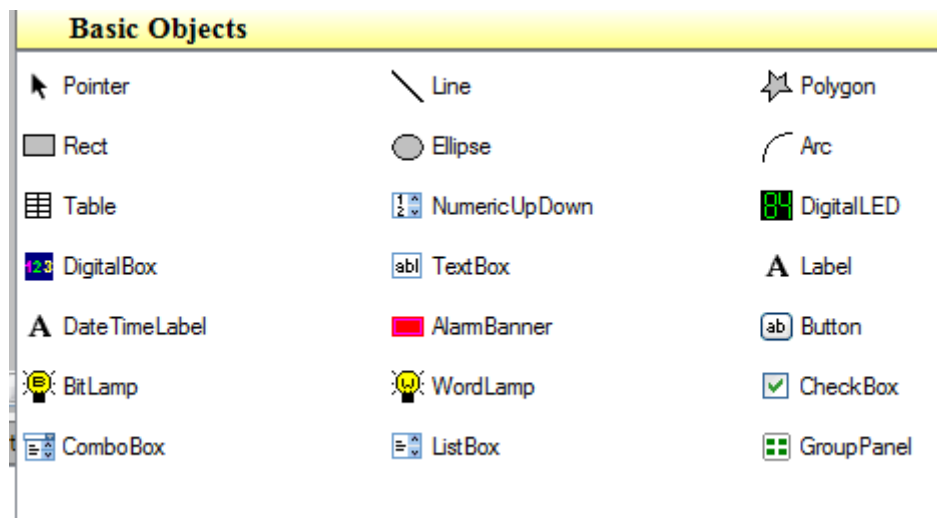

There are three ways to insert the above objects into the screen.

- i) Drag and drop.
- ii) Select the object, say a line, then use the mouse to draw a line on screen.
- iii) Select the object, then double click (mouse left click) quickly by keeping pointer on selected object. Then, the object will appear on screen. For example, select "line" and Double click it 3 times by keep mouse pointer on line, you can see 3 lines appear on the screen.

After inserting object to screen, it is possible to edit its properties either by Graphical User Interface (GUI) dialog or editing properties directly in property grid.

How to edit via GUI dialog

Insert any object in a screen. Select the object, right click the mouse, and then select properties.

Or

Insert any object in a screen. Double click on the Object. A GUI dialog will open automatically.

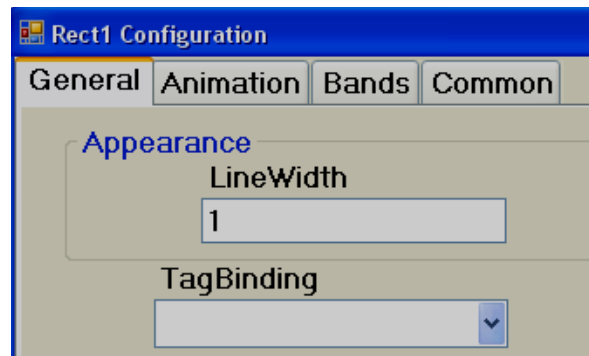

How to edit via Property grid

By default, the property grid will appear at the bottom-right area of the screen editor. If it is not available, click on the "View" drop-down menu, then click "Reset Window Layout". The property grid will appear at bottom right side of the screen editor just below the Project Explorer.

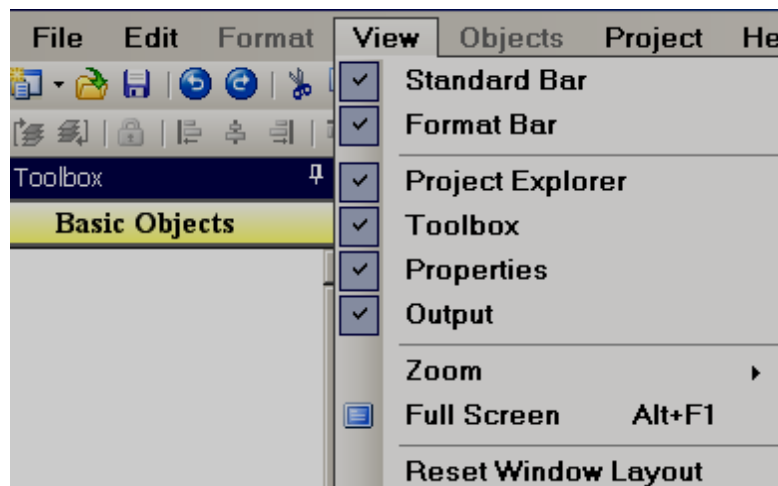

Property grid

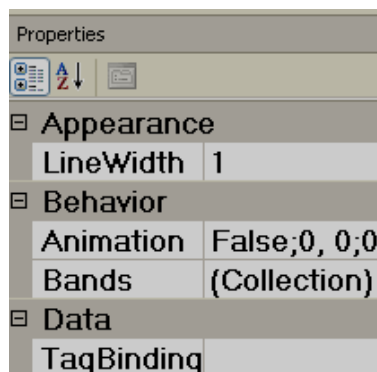

Before placing any objects in screens, check the section File - Environment and set default font size, fill color, fore color and back color for the objects as shown below.

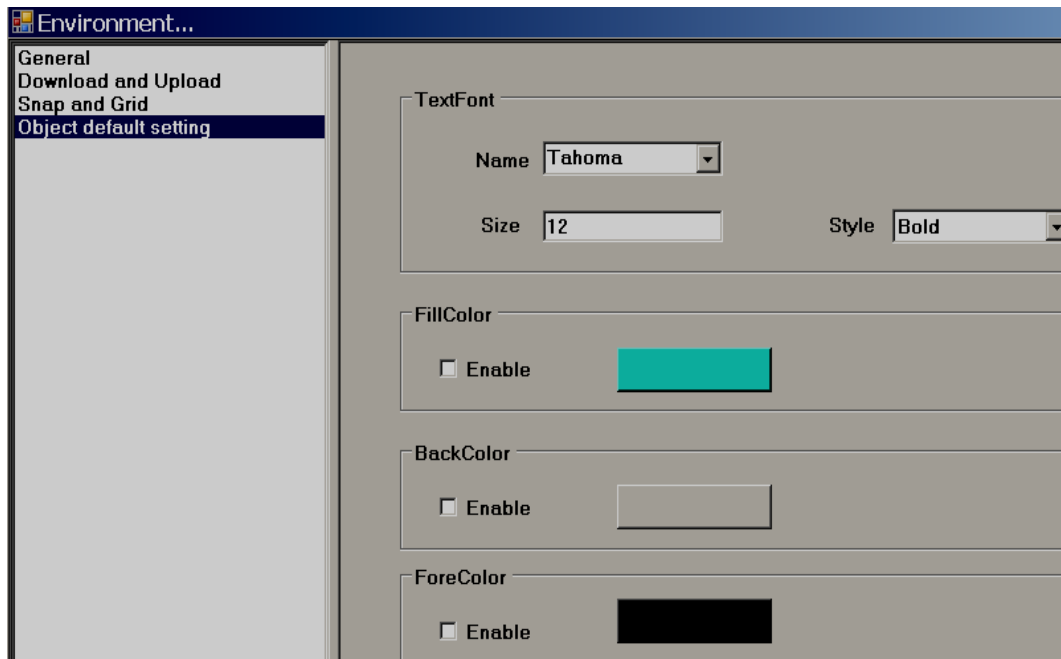

6.3.9.1.1 Common Properties

Appearance

Back Color: Sets the background color of the component.

Fore Color: Sets the Fore color of the component.

Bevel: Used to set the border including inner border, outer border and style of border.

Inner Border: True/False

Outer Border: True/False

Style

9 styles are available. They are None, Flat, Single, Double, Raised, Lowered, Double Raised, Double Lowered, Frame Raised, and Frame Lowered

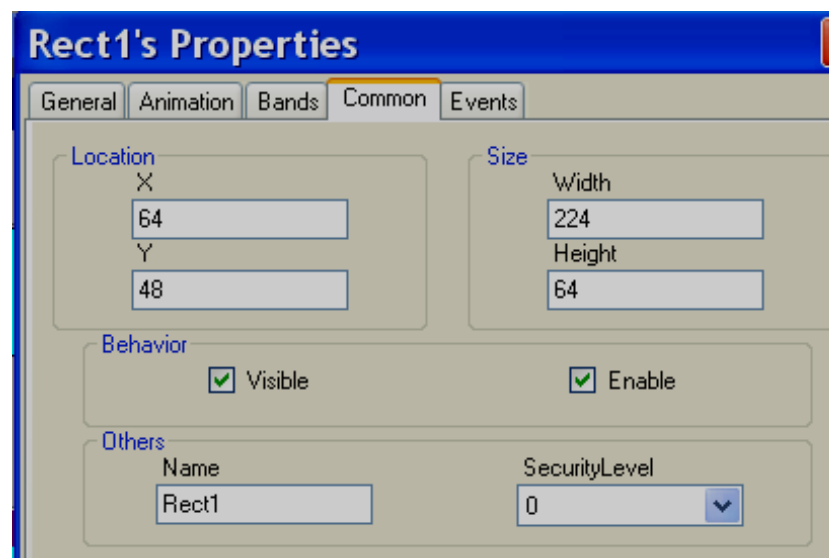

Behaviour

Visible: True/False, determines whether component/control is visible or hidden

Enable: This is for event control. If linked with a Digital tag, when the tag value =1 in run time, events configured for the object will be executed. If the tag value = 0, events will be not executed

Data

Tag Binding: Select the Tag of the desired process value

Write design time value: If selected, it writes the value available at "Text" in design time and in run time replacing the default value defined at Tag database.

Design

Name: It is the name of the component.

Security level: Define the security level for the component.

Locked: True/False: It is to Move or Resize the component.

Layout

Dock: Defines which borders of the control are bound to the container.

Location: The coordinates of the upper-left corner of the component relative to upper-left corner of the container. Set X and Y position in screen in pixels.

Size: Size of the component in pixels. Set height and width of component in pixels.

Pointer: It is to deselect the tool selection.

6.3.9.1.2 Function editor

This is very useful to select different functions to execute based on operator actions. During Run time, this provides an easy way for an application developer to use a ready-made macro instead of writing scripts. Insert a Button into any screen and configure events. The following functions are supported.

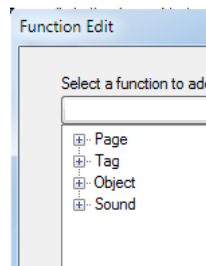

Page Control functions

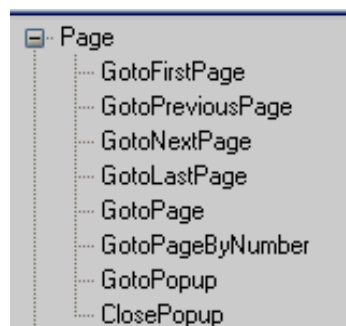

Every screen has a screen number. The pointer will be the screen number for navigation.

GotoFirstPage: It is used to navigate from current screen to first screen

GotoPreviousPage: Used to navigate from current screen to previous screen

GotoNextPage: Used to navigate from current screen to next screen

GotoLastPage: Used to navigate from current screen to Last screen

GotoPage: Used to navigate from current screen to specific screen by name

GotoPageByNumber: Used to navigate from current screen to specific page by number

GotoPopUp: Used to open specific pop up screens by name

ClosePopUp: Used to close pop up screens by name

Tag functions

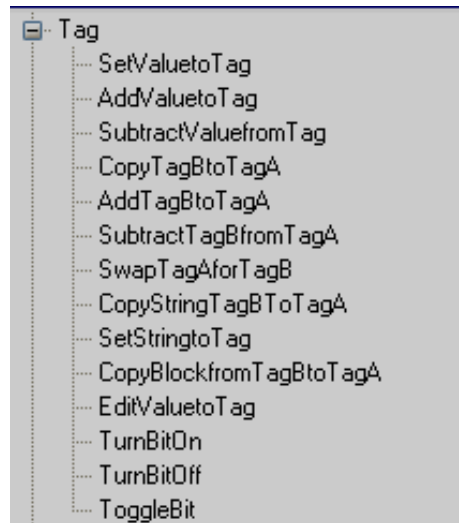

SetValueetoTag: Writes a value to a tag

Example: Set 90 to TagA when operator presses on a button during run time.

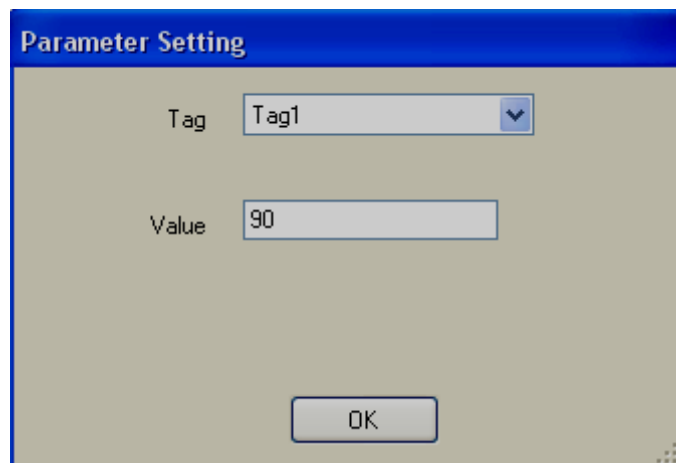

AddValuetoTag: Used to add value to Tag

SubtractValuefromTag: Used to subtract value from Tag

CopyTagBtoTagA: Used to copy TagB value to TagA

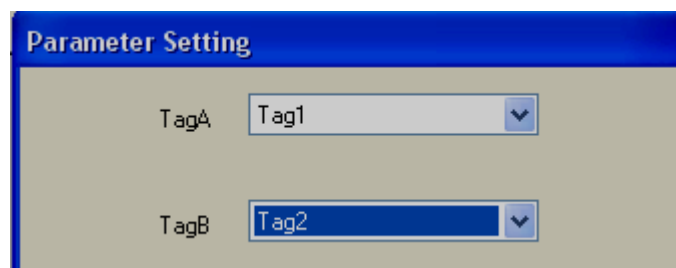

AddTagBtoTagA: Used to add TagB to TagA and store result in TagA

SubtractTagBfromTagA: Used to subtract TagB from TagA and store the result in TagA.

SwapTagAforTagB: Used to swap TagB data with TagA

CopyStringTagBtoTagA: Used to copy the string type of TagB to TagA

SetStringtoTag: Used to write a string to a String type Tag

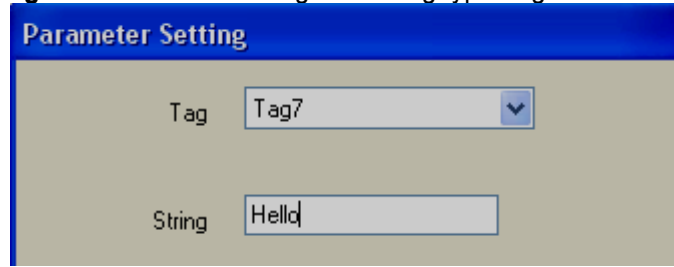

CopyBlockfromTagBtoTagA: Used to copy a block of tags from TagB to Tag1

For example: Copy 4 continuous tags from Tag5 to a target location starting with Tag1. Tag5 is copied to Tag1, Tag6 is copied to Tag2, and so on.

Note: Maximum block size is limited to 80 tags

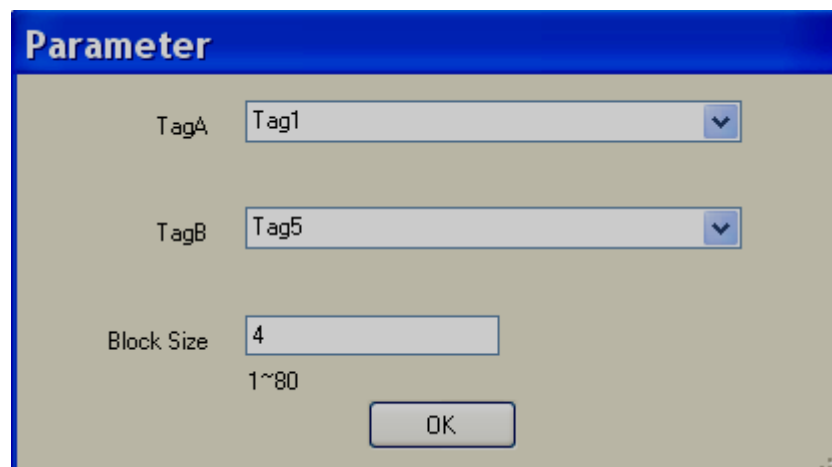

EditValuetoTag: Used to edit tag value during run time from a keypad. For example, if this function is called from button “clicked” event, then, a keypad will open during run time and the user can enter a set point.

TurnBitOn: Used to turn on a bit.

If a momentary Turn on is required, then in “Clicked” action, select Turn On, then, in “Released” action, select “Turn OFF”.

TurnBitOFF: Used to turn off a bit

Togglebit: Used to toggle the bit

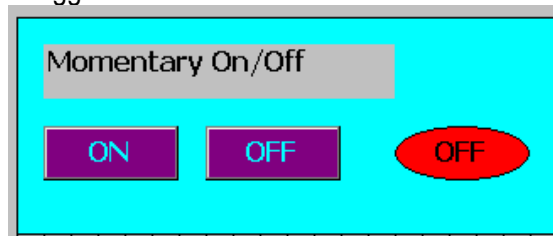

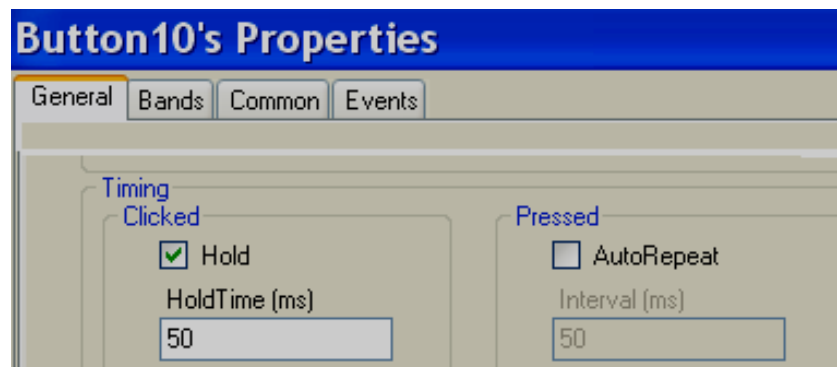
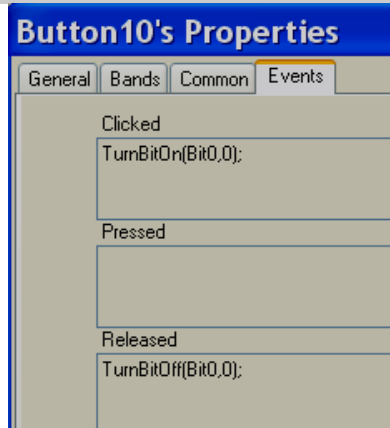
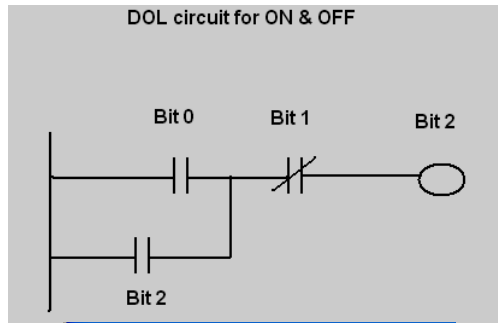

If a button is not switching properly at the PLC, then, in the "General" Tab, select the "Hold" check box and enter the hold time. Default value is 50 msec. If required, adjust this to 100 msec. and check again if the button is switching properly.

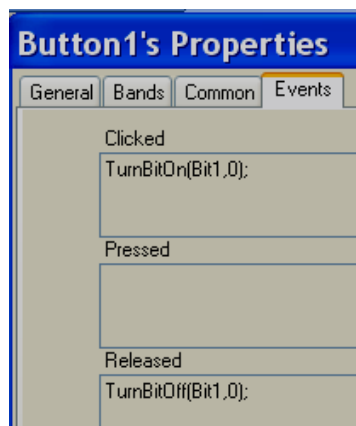

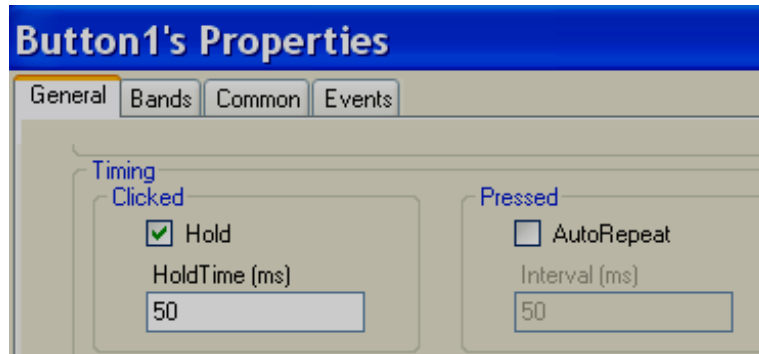

If button is not switching properly at PLC, then, in General Tab, select “Hold” check box and enter the hold time. Default value is 50 msec. If required, adjust this to 100 msec. and check again.

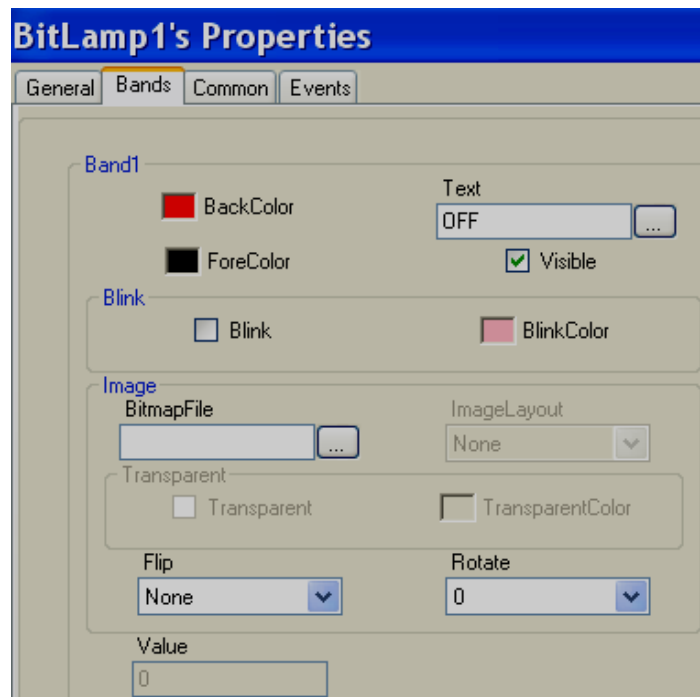
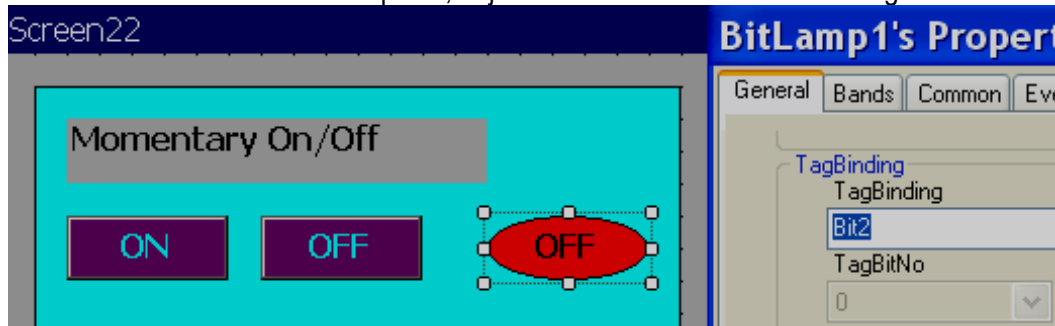

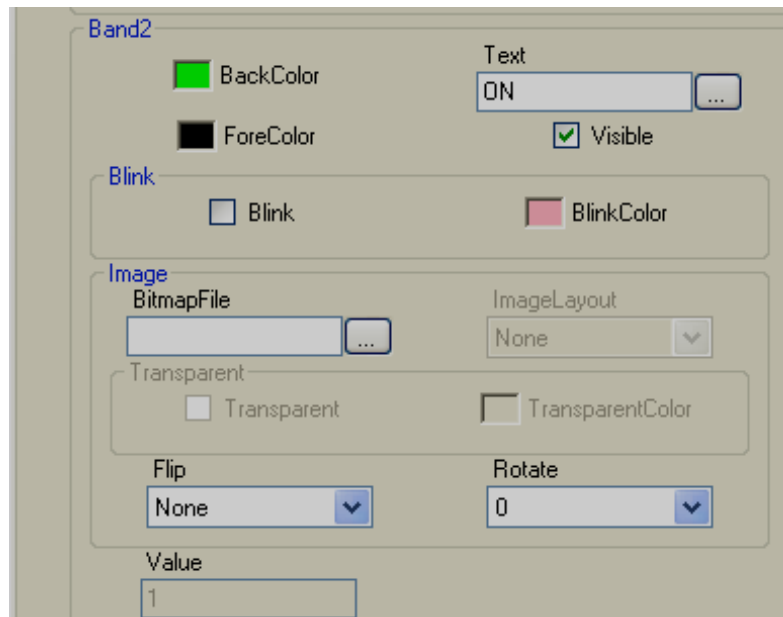

6.3.9.1.3 Line

Line: An object used to draw a line and do animation in Run time when linked with a Tag.
 User can edit properties via GUI dialog or property grid. After drag/drop of object to a screen, double click the object to open the GUI dialog, or, select the object and directly enter properties via the property grid available at bottom right corner of screen editor.

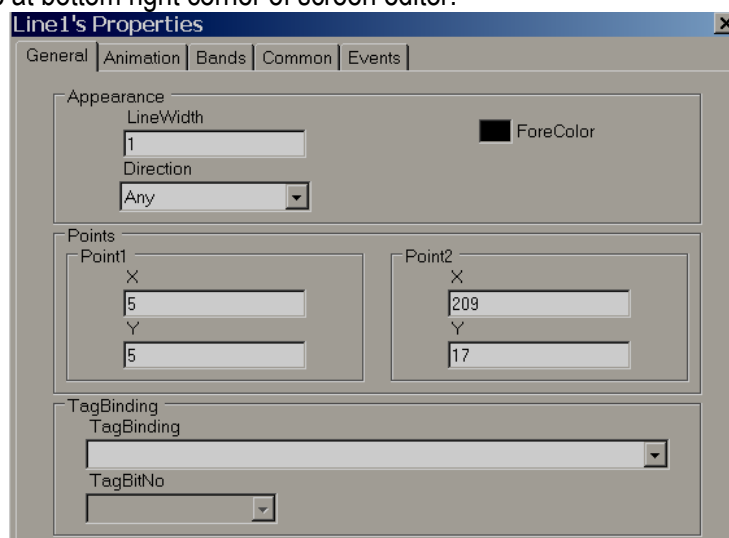

General Appearance

Line Width: Define Line width
Direction: Horizontal or Vertical

Points

Point1: Define X and Y coordinate for line starting point and they show current position.
Point2: Defines the X and Y coordinates for the line end point and shows the current position.

Tag Binding

Select a Tag to be linked with this line. This is useful if animation is required.

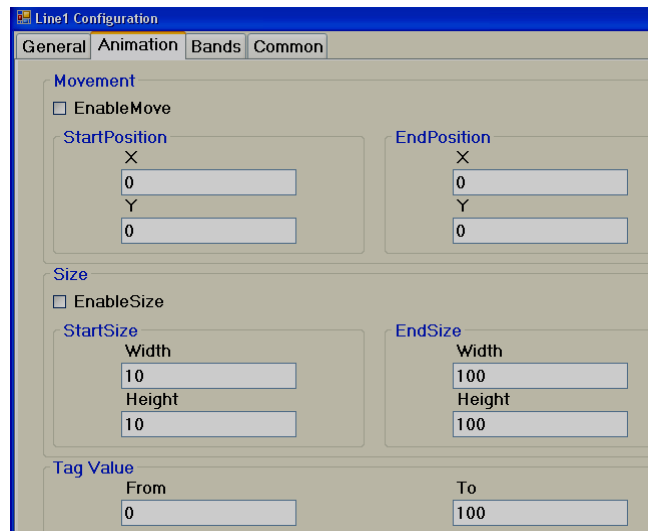

Animation

This is to do animation on line in Run Time

Movement

Select "Enable Move" check box if movement animation is required during Run time.

Start Position: Defines X and Y coordinates for the start position when tag value is at its minimum during Run Time.

End Position: Define X and Y coordinate for end position when tag value is at its max. During run time.

The X position indicates movement from Left to Right, this is Horizontal movement. The Y position indicates movement from Top to Bottom, this is Vertical movement.

For example: Recorder 7" (High Performance) project, 800 X 480 pixels, Normal installation, Horizontal (Left to Right) = 800 pixels, Vertical (Top to Bottom) = 480 pixels

Enable move: Selected

Start position X = 0, Y = 0

End position X = 800, Y = 0

Tag Value, From = 0, Tag Value To = 100

Now, in Run time, when the Tag value = 0, the line will be at the Top left. When the Tag value = 100, the position of the line will be at the Top Right

Size

Select "Enable Size" check box to enlarge/decrease size of component during Run time.

Start Size: Defines X and Y coordinates for the starting size when the tag value is at its minimum during Run time.

End size: Define X and Y coordinate for end size when tag value is max. Run time.

Tag Value

Select a Tag to be linked with this line. This is useful if animation is required to be done on the line.

Bands

This is to select various bands as part of an animation during Run Time

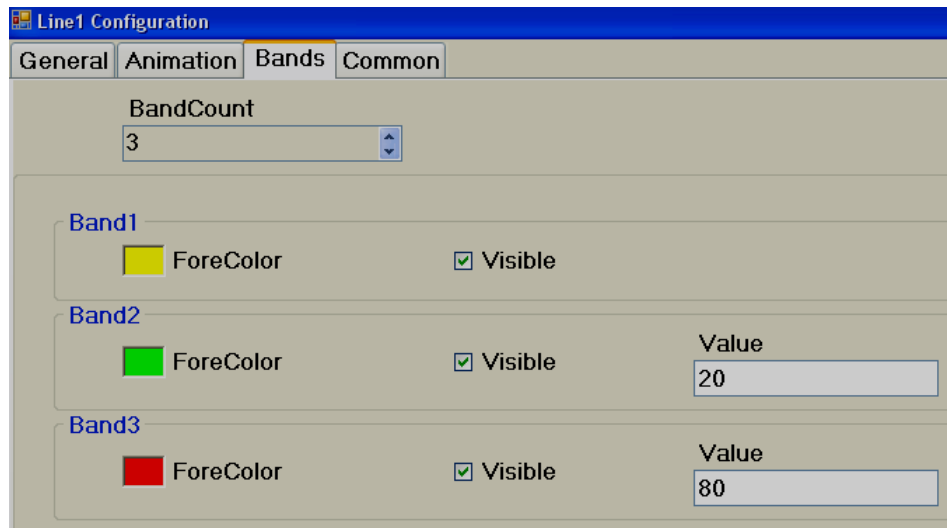

Band Count

A maximum of 32 bands are available.

For example: In the above sample,

If the Tag value is 0 to 20, the line will be Yellow

If the Tag value is 21 to 80, then, line color = Green

If the Tag value is above 80, line color = Red

6.3.9.1.4 Polygon

★ **Polygon:** Used to draw a polygon. After finishing drawing, double left-click the polygon using the mouse to complete the Polygon. It is also possible to link a polygon to a tag and define some user friendly animation to appear during Run time.

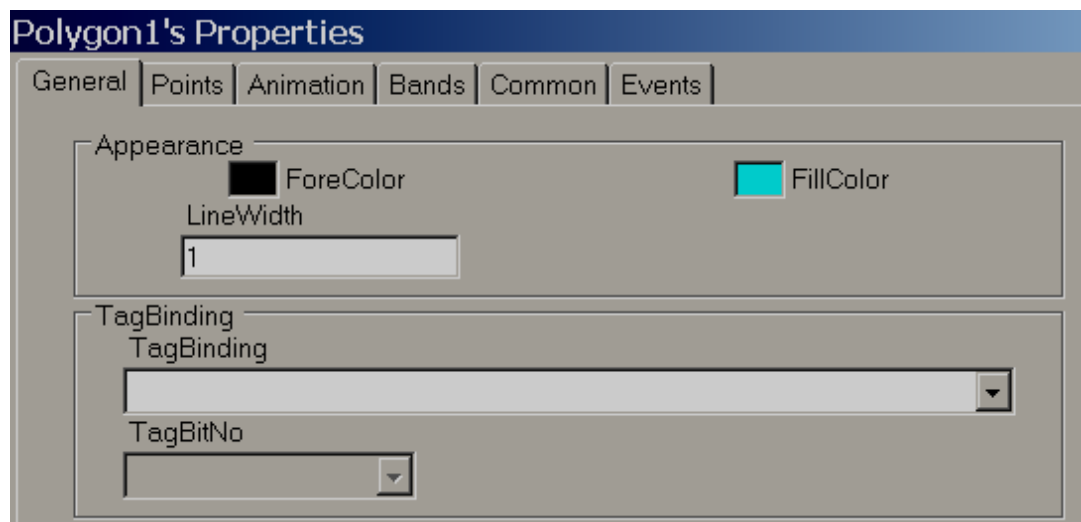

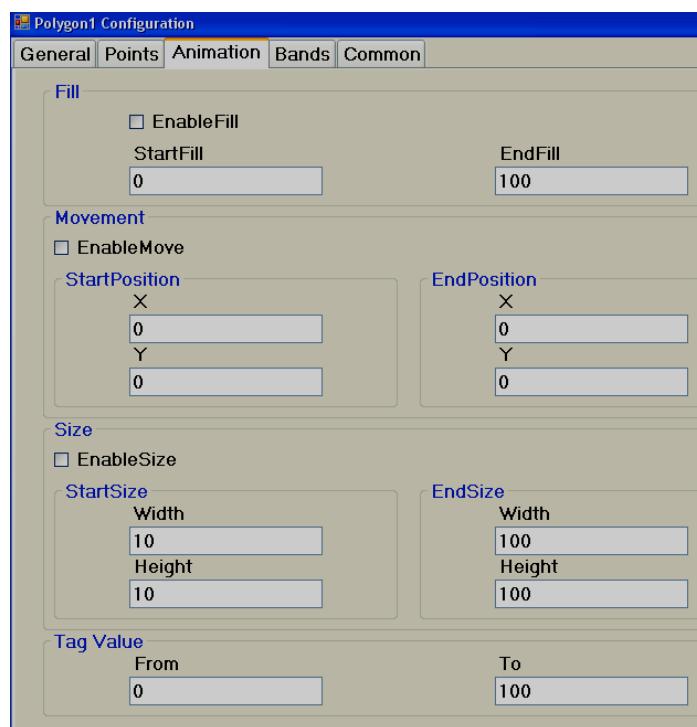
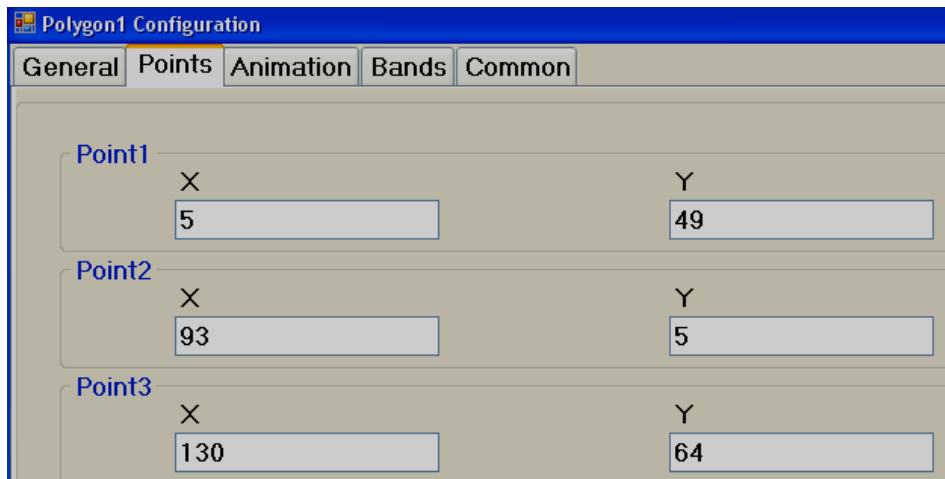

Animation

This is to do animation with a Polygon in Run Time

Fill

Select "Enable Fill" if filling animation is required on a Polygon object during Run time. When a tag value changes during Run time, it shows the polygon filling with a defined color inside the Polygon object. It's like a bar graph where the filling is within the polygon shape.

Start Fill: Defines a Start value for Fill

End Fill: Defines an End value for Fill

Movement

Used to define a movement position. This is the same as previously explained for the Line object earlier.

Size

Used to define the amount of size increase/decrease. This is the same as previously explained for the Line object earlier.

Tag Value

Select a Tag to be linked with the Polygon object. This is useful if animation is required to be done with the Polygon.

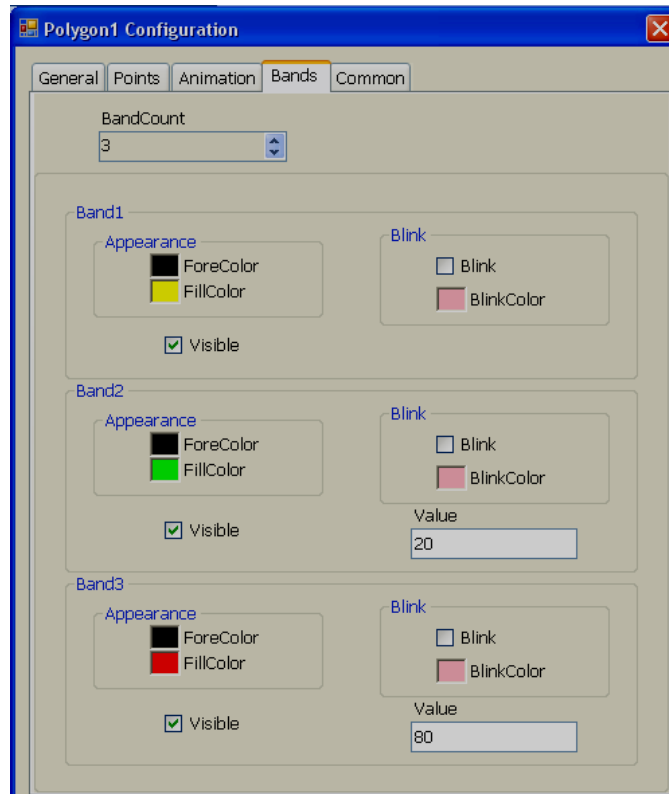

Band editor

A maximum of 32 bands are available.

For example: In the above sample,

If the Tag value is 0 to 20, Polygon fill color = Yellow

If the Tag value is 21 to 80, then, Polygon fill color = Green

If Tag value is above 80, Polygon fill color = Red

If required, it is also possible to configure the blink property and set blink color for any band.

6.3.9.1.5 Rectangle

 **Rectangle:** Used to draw a Rectangle and do animation during Run time when linked with a Tag.

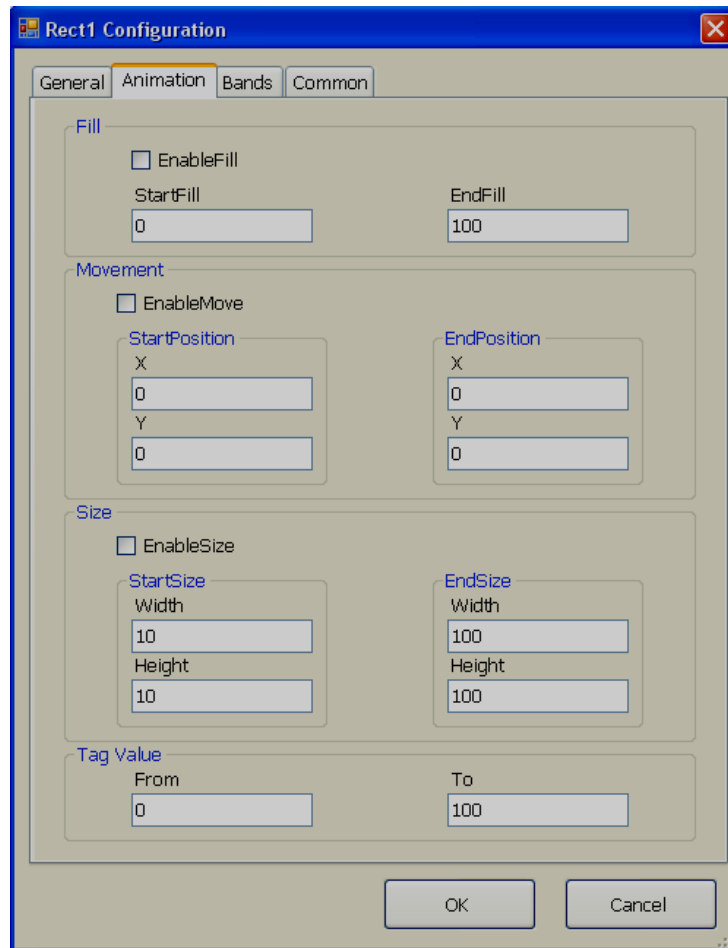
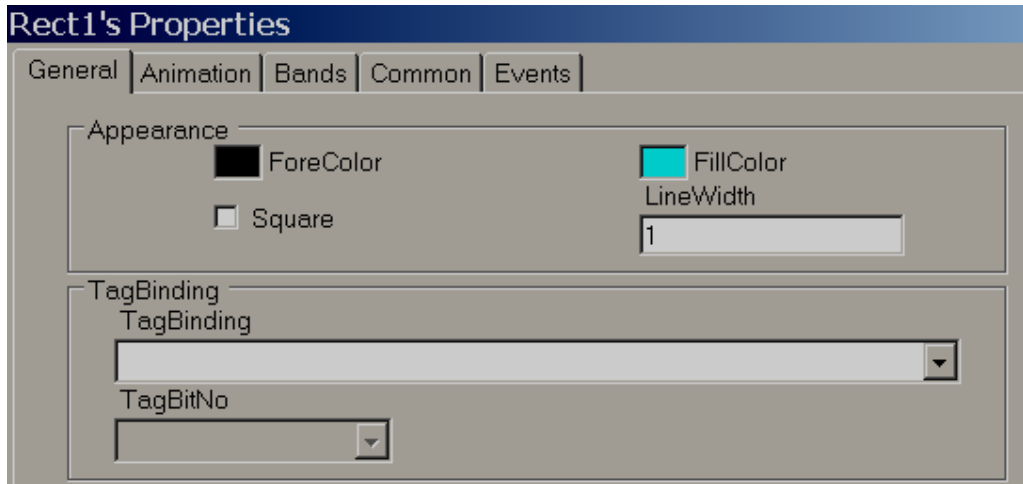

Animation Supported: Fill, Movement and Size

The above features are same as explained for Line and Polygon objects

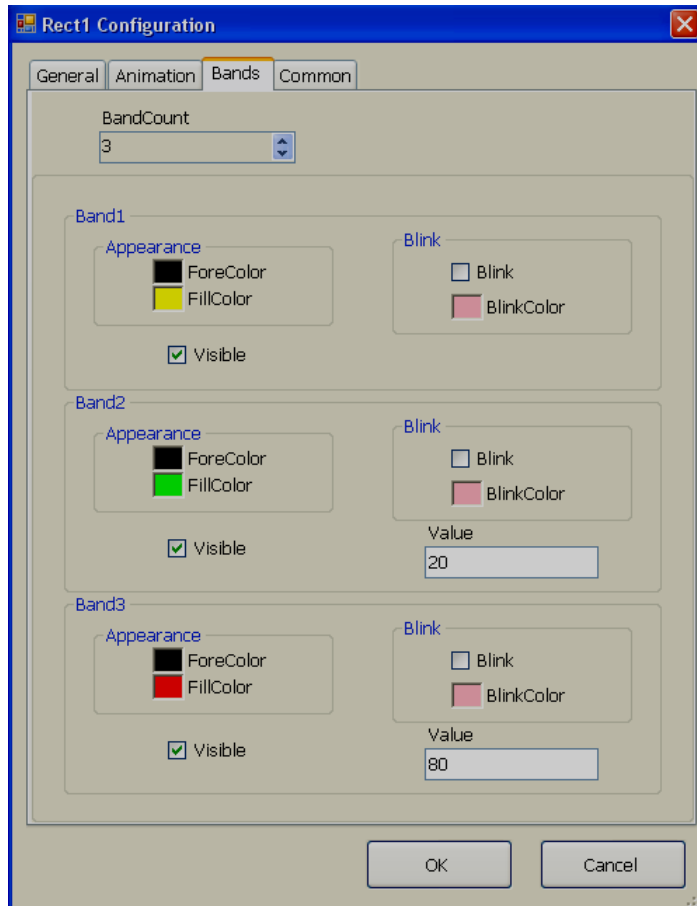

Band editor

A maximum of 32 bands are available.

For example: In the above sample,

If the Tag value is 0 to 20, Rectangle fill color = Yellow

If the Tag value is 21 to 80, then, Rectangle fill color = Green

If the Tag value is above 80, Rectangle fill color = Red

If required, it is also possible to configure blink property and set blink color for any band.

6.3.9.1.6 Ellipse

Ellipse: Used to draw an Ellipse or a circle and do animation during Run time when linked with a Tag.

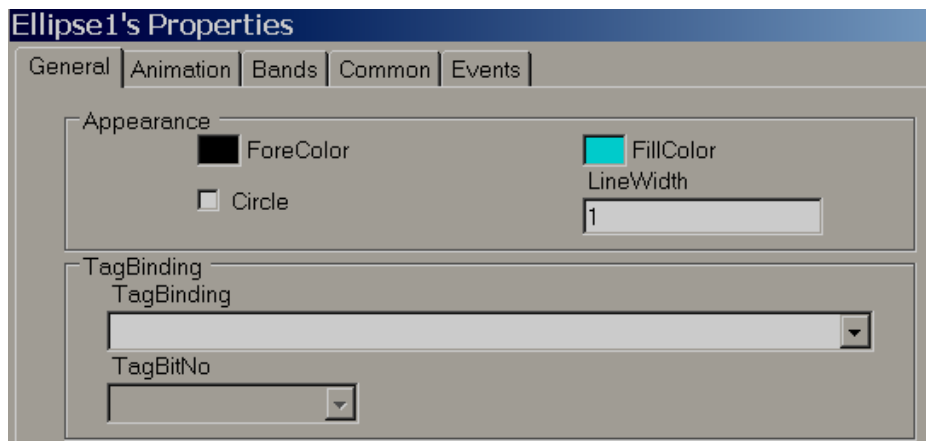

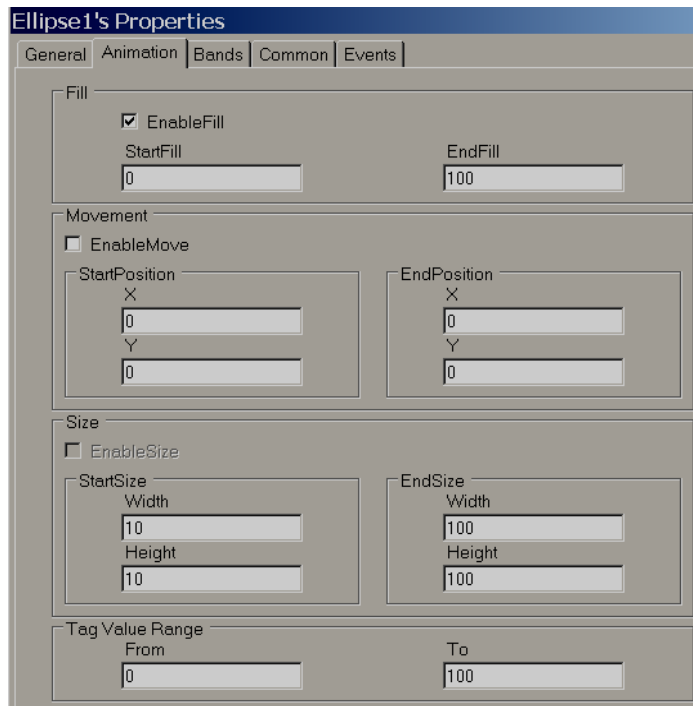

Animation Supported: Fill, Movement and Size

The above features are the same as explained for Line and Polygon objects.

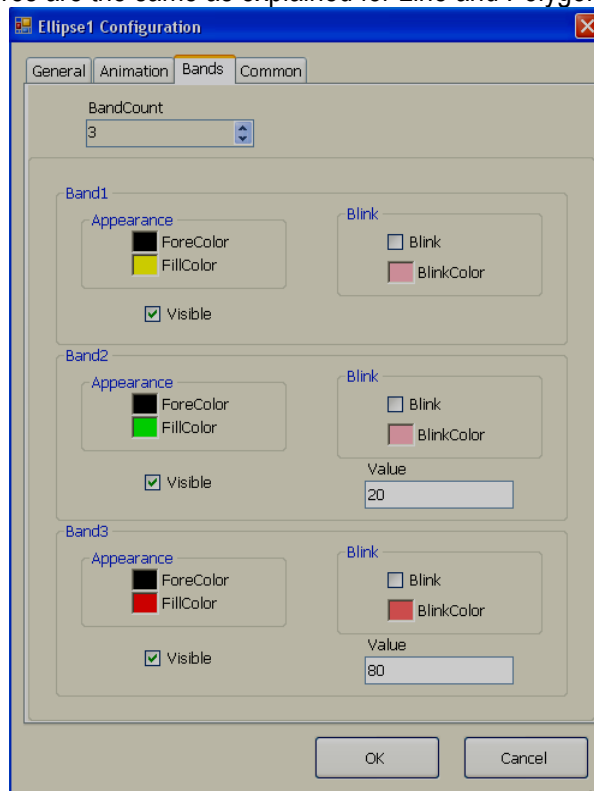

Band editor

A maximum of 32 bands are available.

For example: In above the sample,

If the Tag value is 0 to 20, Ellipse fill color = Yellow

If the Tag value is 21 to 80, then, Ellipse fill color = Green

If the Tag value is above 80, Ellipse fill color = Red

If required, it is also possible to configure blink property and set blink color for any band.

6.3.9.1.7 Arc

Arc: Used to draw an Arc and do animation during Run time when linked with a Tag.

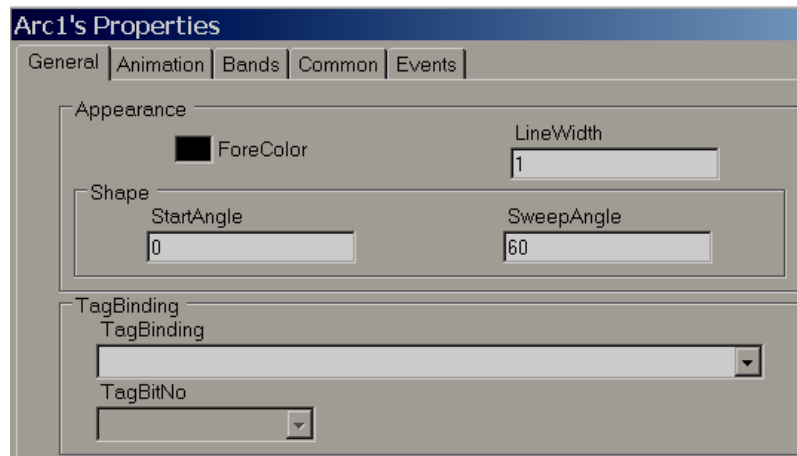

Start Angle: Defines the start angle.

Sweep angle: Defines the end angle

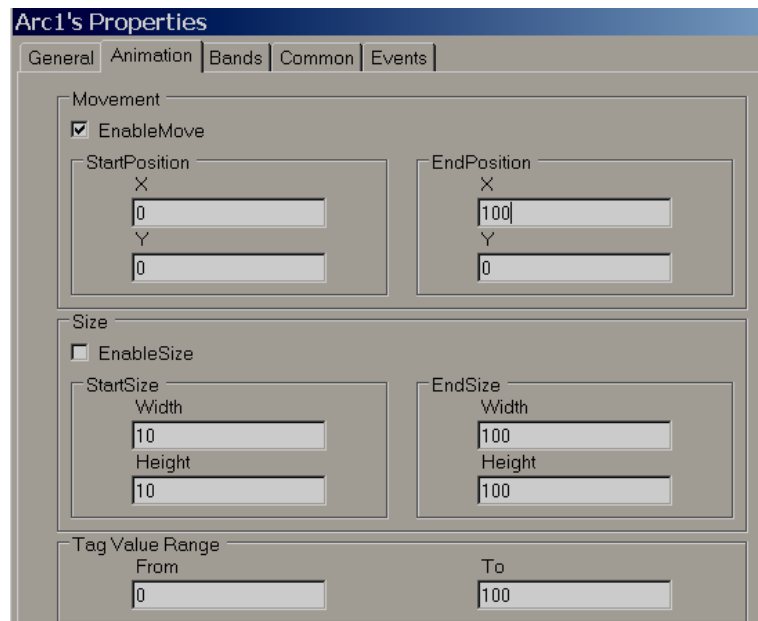

Supported Animation: Movement and Size

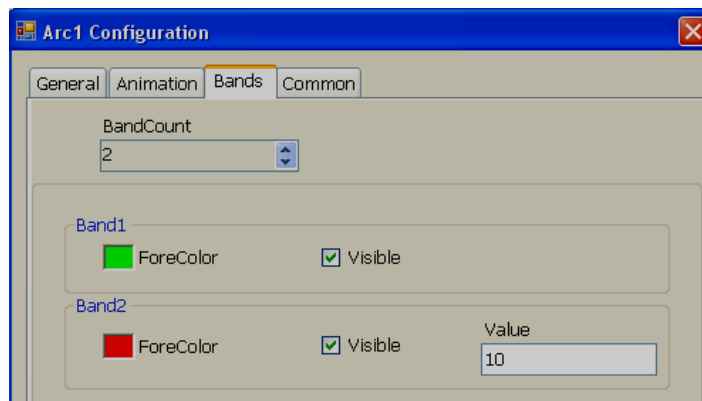

Band editor

A maximum of 32 bands are available. Band editor for “Arc” is the same as explained for the “Line” object earlier.

6.3.9.1.8 Table

It is used to draw a table during design time by specifying number of rows & columns. All rows/columns will have an equal width and height. It is possible to place labels on rows (Linked with Tags) for displaying process values to appear like a tabular column. User can edit properties via the GUI dialog or Property grid as per convenience. After dragging/dropping the object to the screen, double click on the object to open GUI dialog.



While working with a Table, in page properties, select Snap to Grid = False so that it will be easy to place labels/textboxes in required positions easily.

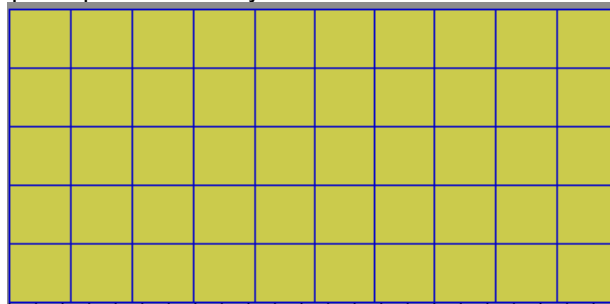

Drag and Drop Table from Basic objects to the screen, then double click on Table. The following screen will open.

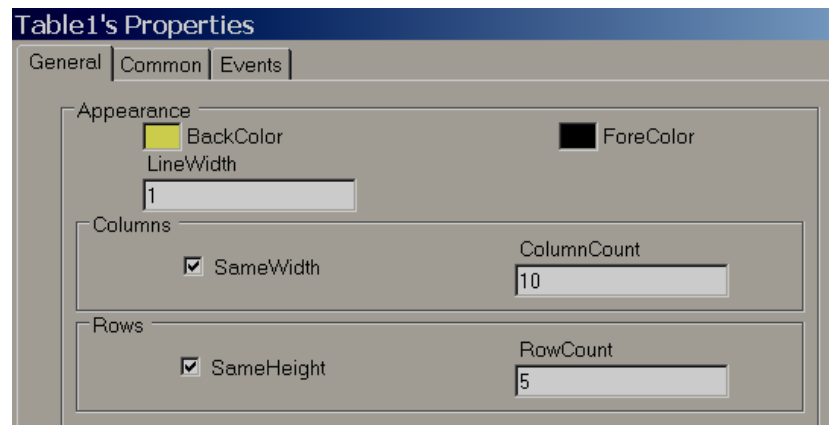

Note: Deselect “Same Width” to adjust Column width in the Table

Note: Deselect “Same Height” to adjust Row height in the Table

Property grid

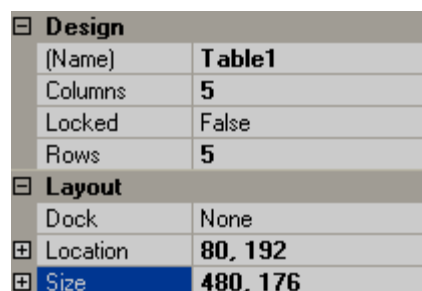
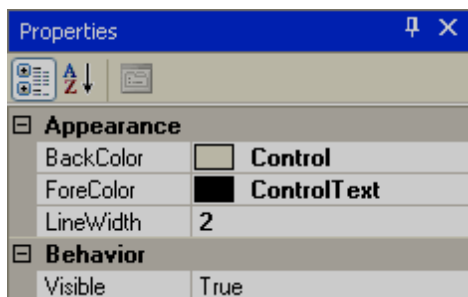

Properties

Back Color: It is the back color of the table

Fore Color: It is the color for the lines of the table

Line Width: It is the width of the lines of the table

Columns: Defines the number of columns in the table

Rows: Defines number of rows in the table

Name: The unique name for the table in a specific page

Locked: Used to determine if table is locked for further moving and resize in design time and user can set this in property grid.

6.3.9.1.9 Numeric Up/Down

Numeric Up/Down is a Graphical User Interface widget that allows the user to increase or decrease the value of a tag by pressing up or down arrows during Run time, or to enter a numeric value directly via a keypad. Users can edit properties via GUI dialog or Property grid for convenience. After drag/drop of a numeric up/down object to the screen, double click on the object to open GUI dialog.

Every Numeric Up/Down button should be linked with an **Analog** Tag.



Except the Up/Down arrow, if a user presses another area of the Numeric Up/Down component in the recorder during Run time, a numeric keypad will open. The user can then enter a numeric value directly. The numeric keypad will not appear in the PC during Online/Offline simulation, user can use the keyboard directly to enter a numeric value.

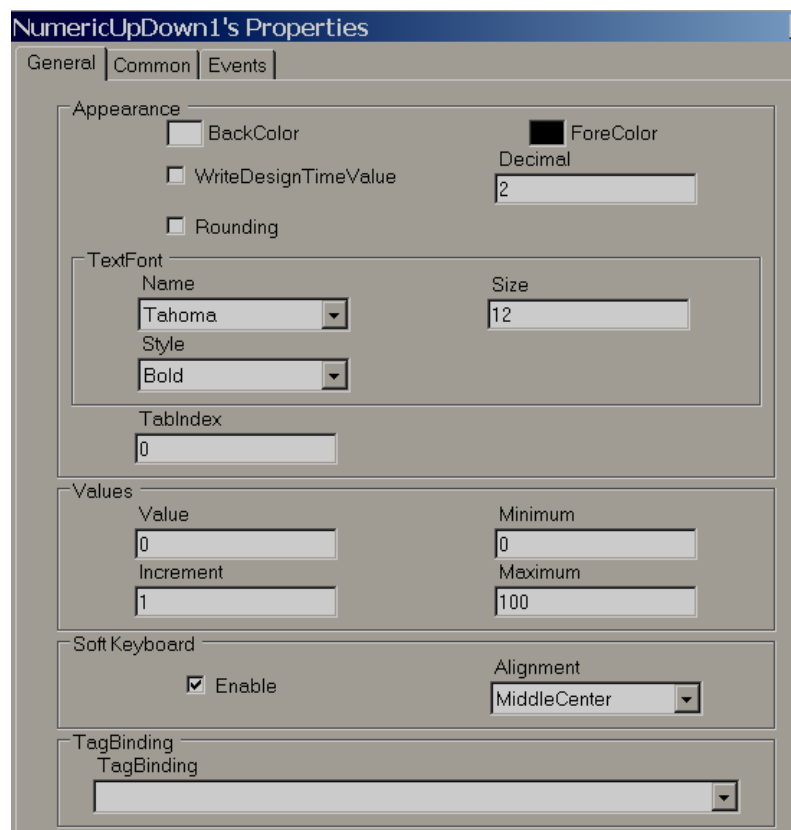

Increment

Select the value to be incremented/ decremented each time when the up/down arrow is pressed during Run time.

Properties

Write design time value: If selected, it writes value available at "Text" during design time and also during run time replacing the default value defined in the Tag data base.

Rounding: Rounds to nearest value

Decimal: Enter the number of decimal points

Value: Current Tag value. It is used to enter a value during design time and to check how a value is displayed during Run time.

Increment: Value to be incremented during Run time after pressing Up/Down button.

Minimum: Defines the minimum value

Maximum: Defines the maximum value

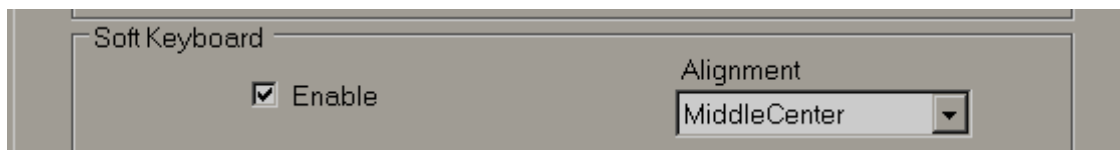

Soft keyboard

If enabled, it is possible to control the keypad appearance during run time. For example, if alignment is selected as Middle center, then, when keypad appears in run time, it will be located to Middle center in screen

Events

Defines events to be executed when the operator presses the Up/Down arrow and changes the value during Run time.

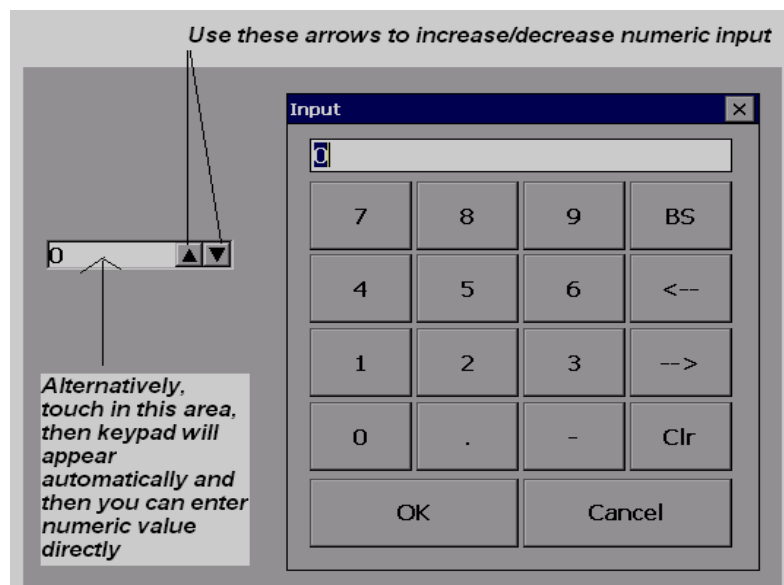

6.3.9.1.10 Digital LED

This object is used to view a process value in a digital format. Generally, it is linked with an analog type tag (example: an analog input tag at a PLC, which is received as 4-20 mA signals from field transmitters to define things like Temperature, Pressure, Flow, Level, Position etc.)

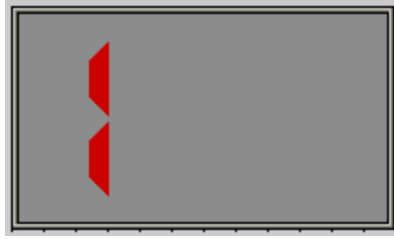

For common properties like Back Color, Bevel, etc., please refer section “Common Properties

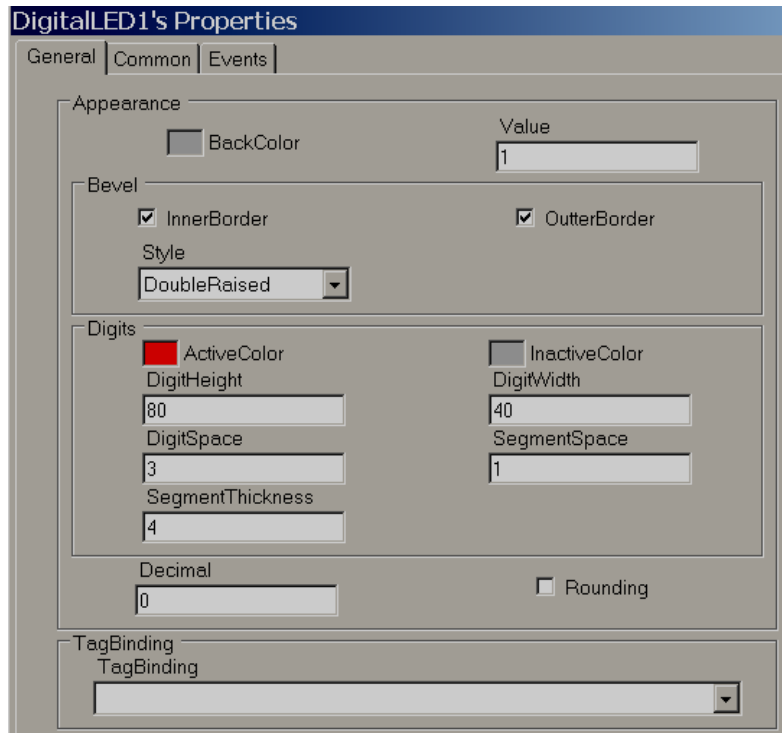

Property grid

Digits		Red,80,3,40,Color [Silver]
ActiveColor		Red
DigitHeight		80
DigitSpace		3
DigitWidth		40
InactiveColor		Silver
SegmentSpace		1
SegmentThickness		10

Properties

Back Color: Defines background color for the component

Inner border: Select if inner border is required for the component

Outer border: Select if outer border is required for the component

Style: Defines border style. Available options are Single, Double, Raised, Lowered, Double Raised, Double Lowered, Frame Raised and Frame Lowered

Active Color: Defines Active Color of Segment for Digits

Inactive Color: Defines color of inactive segments. In the seven-segment LED display, some segments may be active and some other segments may be inactive depending on numeric values.

Digit Height: Defines height of digits

Digit Width: Define width of digits

Digit Space: Defines the space between digits

Segment Space: Defines the space between segment to segment for digits

Segment Thickness: Defines thickness of segments for digits

Decimals: Defines the number of decimal points

Tag Binding: Selects the Analog Tag of process value

6.3.9.1.11 Digital Box

Digital Box is a Graphical User Interface widget that displays a digital tag value along with four predefined labels as attributes for the process value in Run time.

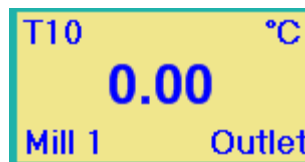
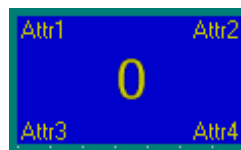

Digital Boxes are normally used with **Analog** tags to display process values like Temperature, Pressure, and Flow etc. They also allow 4 different labels as attributes for displaying tag related information.

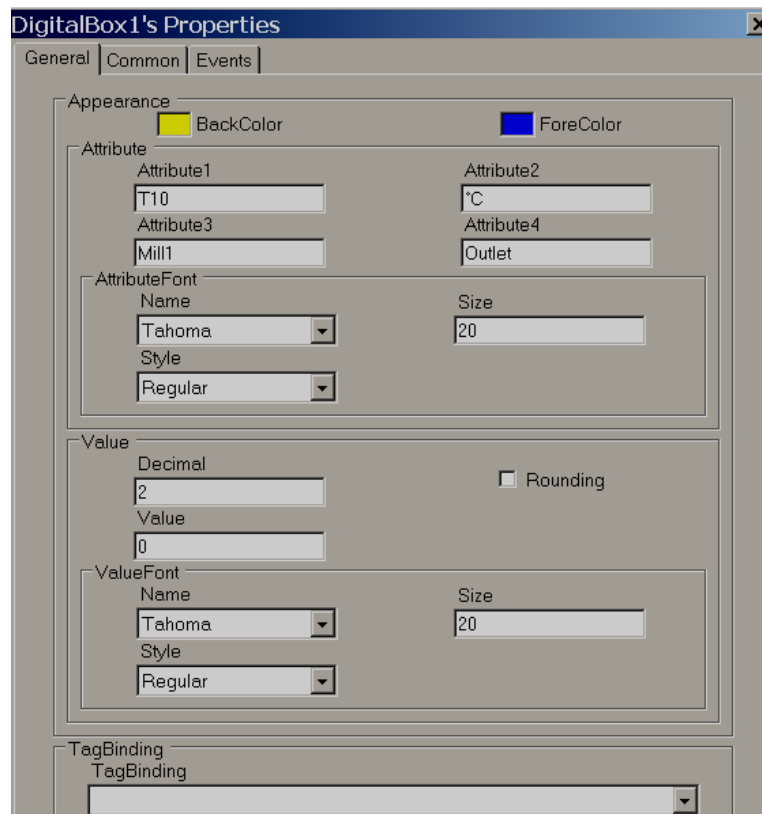

Appearance	
Attribute1	T10
Attribute2	*C
Attribute3	Mill 1
Attribute4	Outlet
AttributeFont	Microsoft Sans Serif
BackColor	Khaki
Decimal	2
ForeColor	Blue
ValueFont	Arial,20,Bold

Behavior	
Value	0
Visible	True
Data	
TagBinding	Tag3
Design	
(Name)	DigitalBox1
Locked	False
Layout	
Dock	None
Location	176, 224
Size	256, 112

Properties

Attribute1: attribute to be displayed at Top left side of Digital Box

Attribute2: attribute to be displayed at Top Right side of Digital Box

Attribute3: attribute to be displayed at Bottom Left side of Digital Box

Attribute4: attribute to be displayed at Bottom Right side of Digital Box

Attribute font: Define font for attribute, select type font, and size of font and style of font. Styles include Regular, Bold, Italic, Underline, and Strike out.

Back color: Defines background color

Fore Color: Define fore-color for the font

Decimal: Defines number of decimal places for the value to be displayed

Value font: Used to adjust the size of the display process value font, select type of font, size of font and style of font. Styles include Regular, Bold, Italic, Underline and Strike out.

6.3.9.1.12 Text box

Used to Read/Write Alpha numeric text in Run time. It can be linked with any type of tag.

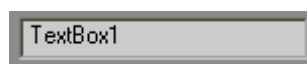

If the object is linked with String type tag, an alpha-numeric keypad opens during Run time if a user touches the object. If the object is linked with an Analog or Digital tag, a numeric keypad opens during Run time if a user attempts to touch the object. If a digital tag is used, make sure “decimal” is set to 0.

Alpha numeric keypad

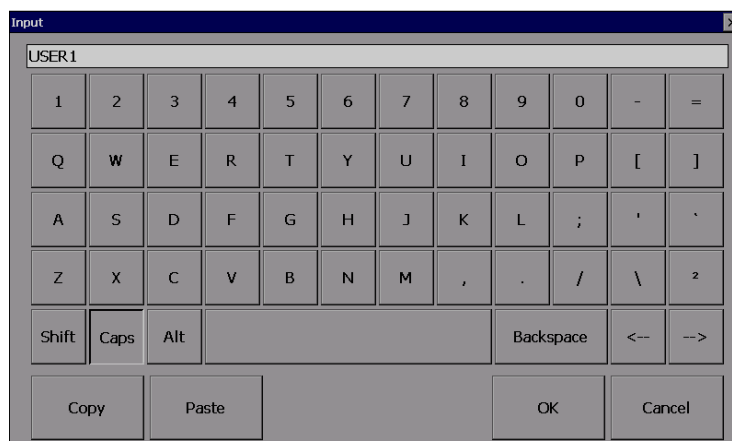

Numeric keypad

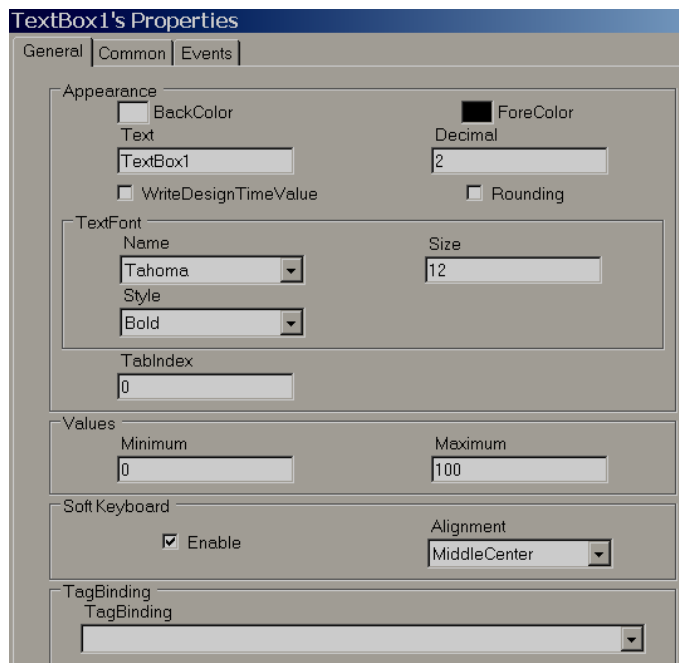
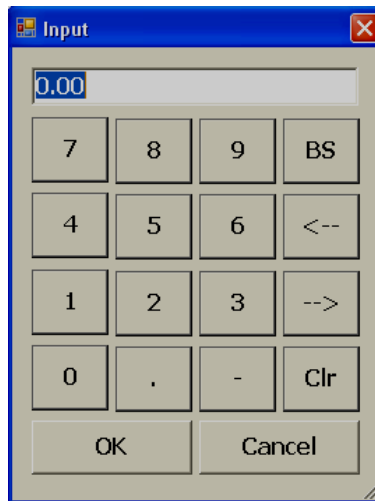

Note: For common properties of all components, please check the beginning of this section.

Write design time value: If selected, it writes the value available at “Text” during design time and also during run time replacing the default value defined in the Tag database.

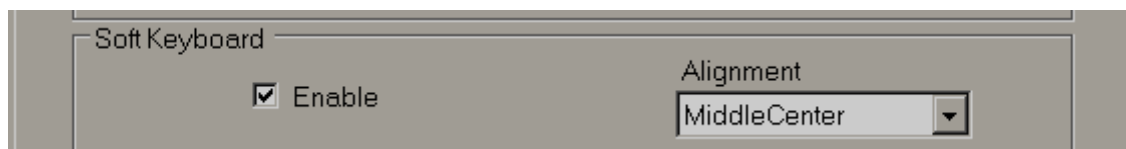

Soft keyboard: If enabled, it is possible to control the keypad appearance during run time. For example, if “alignment” is selected as Middle center, then, when the keypad appears during run time, it will be located in the middle-center of the screen

Appearance	
BackColor	<input type="checkbox"/> White
Decimal	2
ForeColor	<input checked="" type="checkbox"/> ControlText
Password	
Text	TextBox1
TextFont	Tahoma,12,Bold
Behavior	
Visible	True
Data	
TagBindin	Tag1

Design	
(Name)	TextBox1
Locked	False
SecurityL	0
Events	
Changed	
Layout	
Dock	None
Location	96, 96
Size	112, 24
Misc	
WriteDesi	False

6.3.9.1.13 Label

The "Label" object is used to write a simple line of text for user information in the screen. Example: Tag name, Pump number display etc. It is also used to display process values (read only) to operators if linked with a Tag.

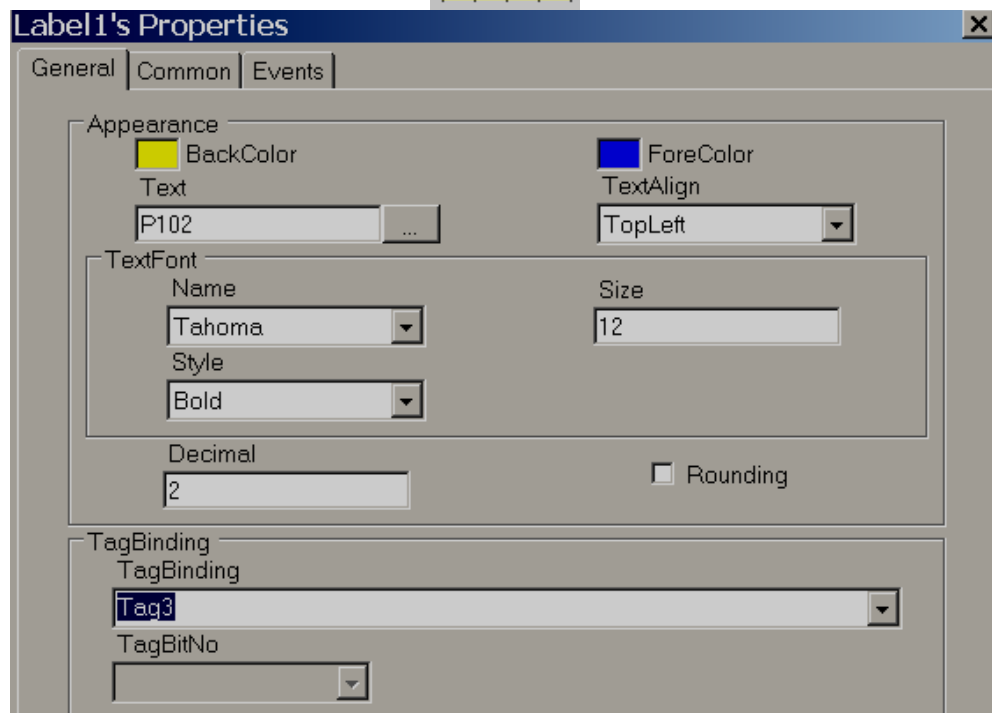
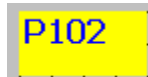

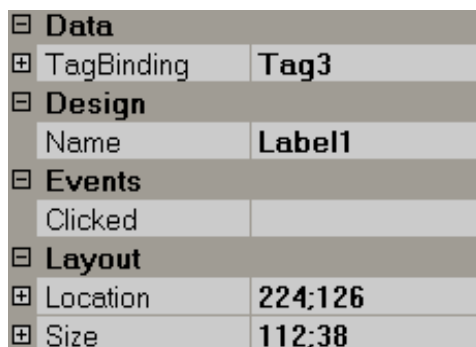
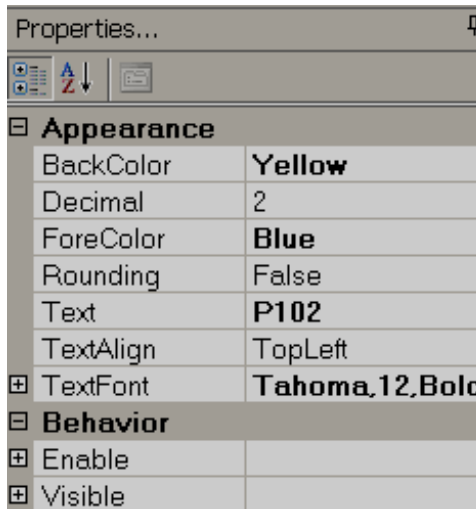

Note: For common properties of all the components, please check beginning of this section.

Properties

Text: Defines text associated with this component and it should be entered at design time only.

Text Align: It is for Alignment of text. Available options include Top Left, Top Center, Top Right, Middle Left, Middle Center, Middle Right, Bottom Left, Bottom Center and Bottom Right

Text Font: Defines font for text including type of font, size of font and style of font. Styles include Regular, Bold, Italic, Underline and Strikeout.

Tag Binding: Select the Analog Tag of a process value

Decimal: Defines the number of decimal points

6.3.9.1.14 Date and time Label



Used to display Date and Time in screen.

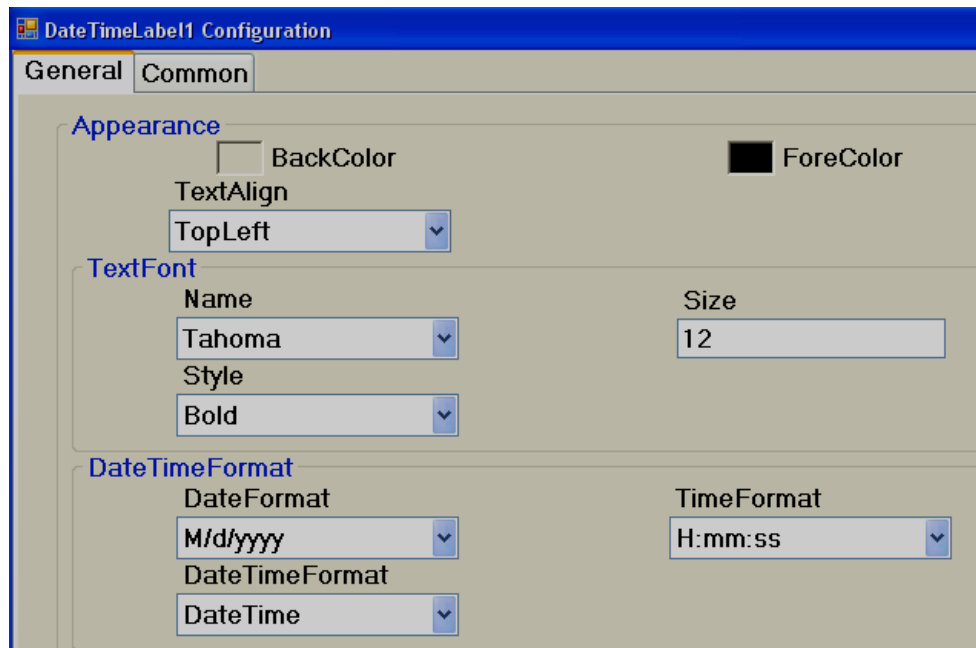

If date and time is required in more than one screen, it is better to create a screen and select the screen type as “Template”, and then link this template to all other required screens to display Date and Time automatically. This is more efficient than keeping Date and Time label in more than one screen, since it uses less memory.

6.3.9.1.15 Button



A Button is commonly used to perform an action after operator presses it with their finger, or by clicking using a mouse during Run time.

Generally, “Button” is used to turn ON a bit, Turn OFF a bit etc. when used with Digital type tags. Example: Start Pump, Stop pump etc.

Three kinds of “Events” are supported for a button. Clicked, Pressed and Released. Several functions are supported which can be configured from “Events” and all the functions are covered in next section “Function editor”.

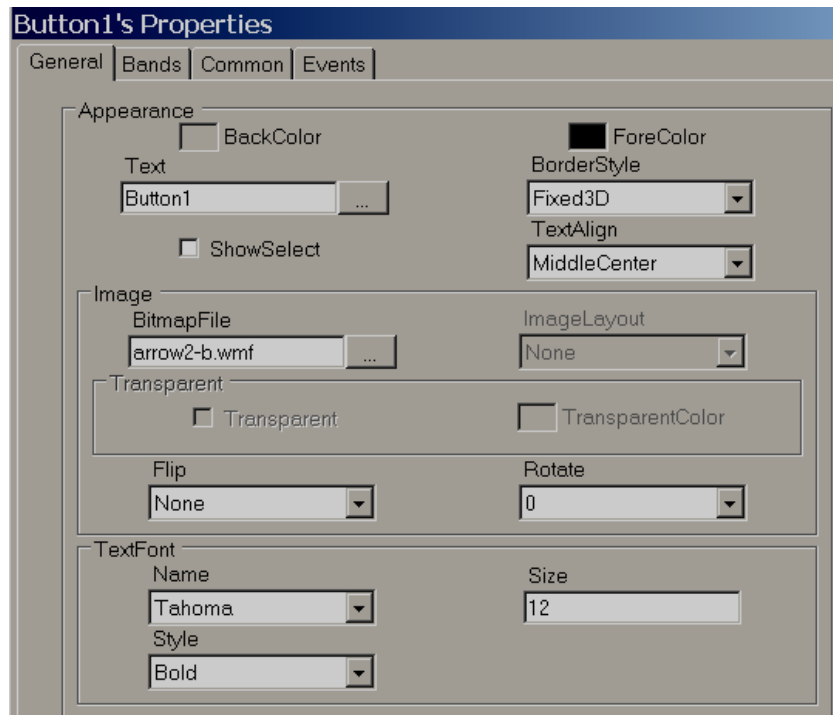

Properties

Back Color: Selects Back color for the object. Also, it is possible to select transparent mode if required.

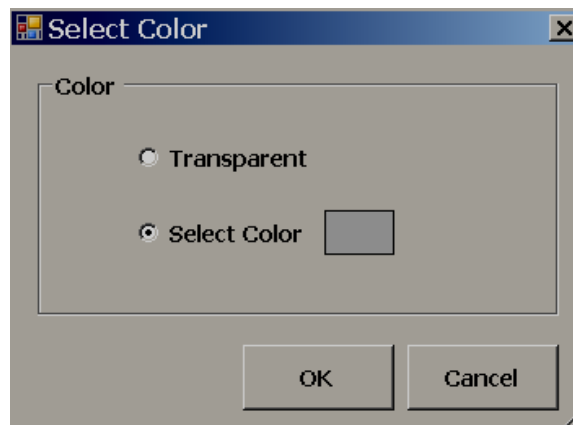

Text: Defines required text to be displayed on the object. It is also possible to enter multi-line text from firmware V1.20 onwards

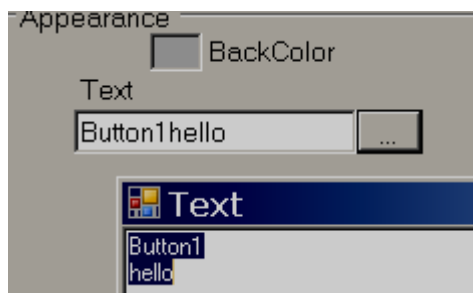

Show select: True/False. If it is selected, then, when the operator presses this button, it will show a dotted line just inside the button. When the operator presses another

button, it automatically shows selected “show” status to latest button and deselect “select” status for previous button pressed by the operator.

- Border Style:** Defines border style. Available options include none, fixed single and fixed 3D
- Image:** Selects the Image to be displayed on the object. Image can be selected from either Basic symbols or Symbol factory, or a custom image can be used if they are formatted as bmp, wmf, jpg, gif or png.

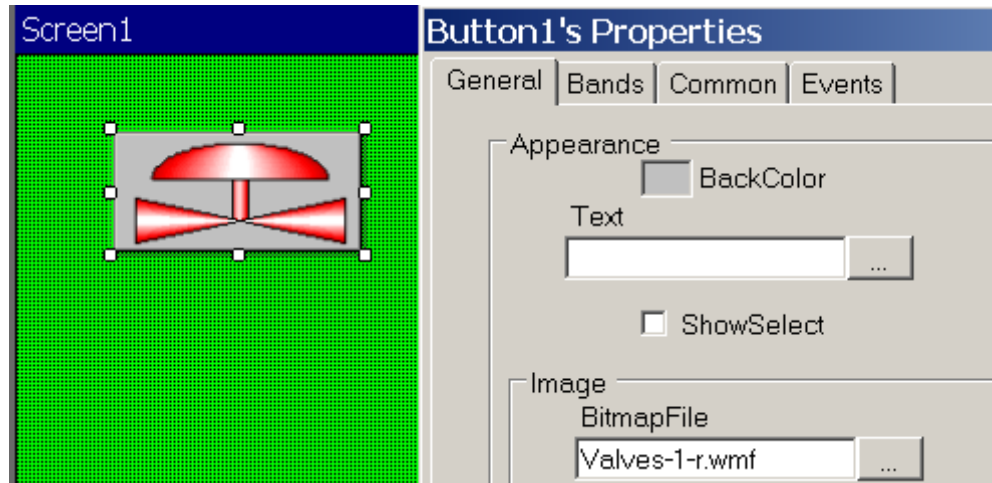

Text font: Define the font including name of font, size of font and style of font

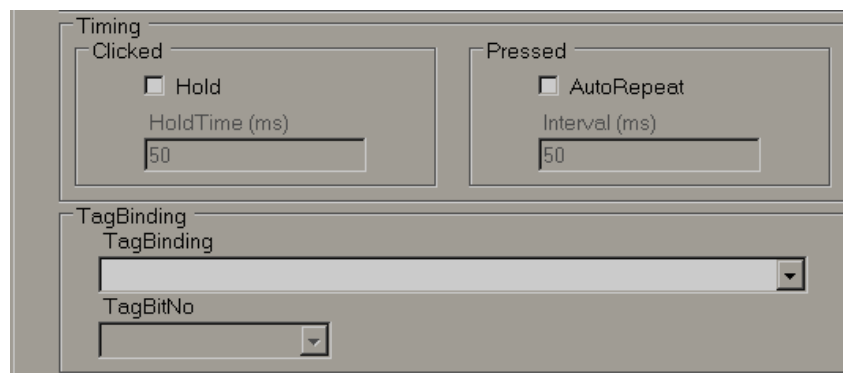

Timing: This is an advanced feature and used to make sure operator action is properly received by PLC when the PLC has a large scan time.

Hold time: This is generally applicable for a “Clicked” event. This keeps executing the action defined at the “Clicked” event for the time defined at hold time. We suggest using holding time greater than the PLC scan time. Example: 300 msec.

Example:
Push button Function

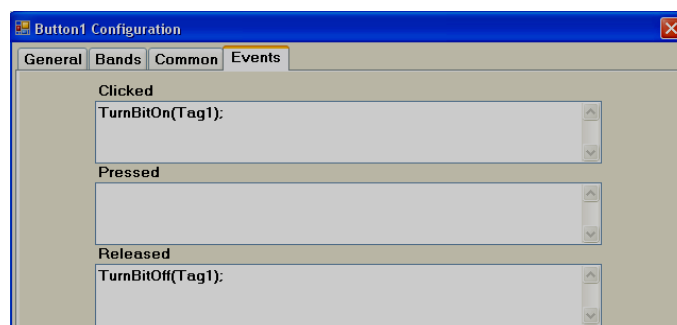

Example: Operator presses button for only 200msec. When operator clicks the button, Tag1=1. When operator releases the button, Tag1 = 0, holding time = 1000 msec.

Since holding time is set for a clicked action, the released action "TurnBitOff" will be executed only after completing 1000 msec, not immediately after the operator releases the button. In this case, if the PLC scan time is 800 msec, the operator click action will be detected properly because the button will remain active for 1000 msec.

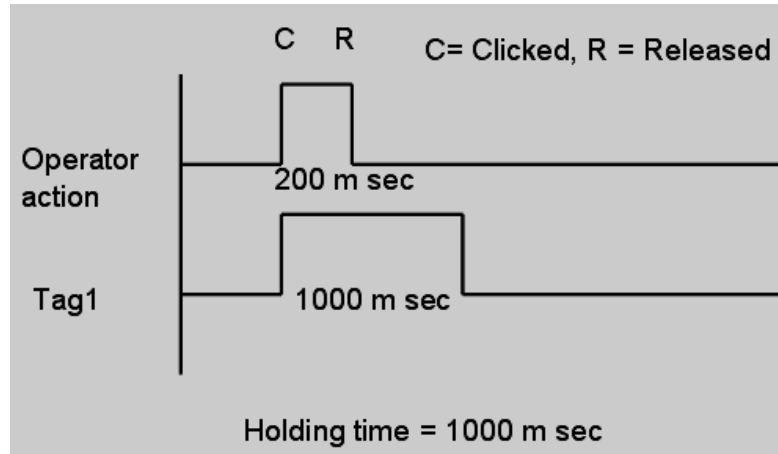

Auto Repeat & Interval time: This is generally applicable for a "Pressed" event. It is to repeat the action defined at the "Pressed" event as per the set interval time.

Example: When operator keeps the button pressed, the set point should be incremented by 1 for every 1 second.

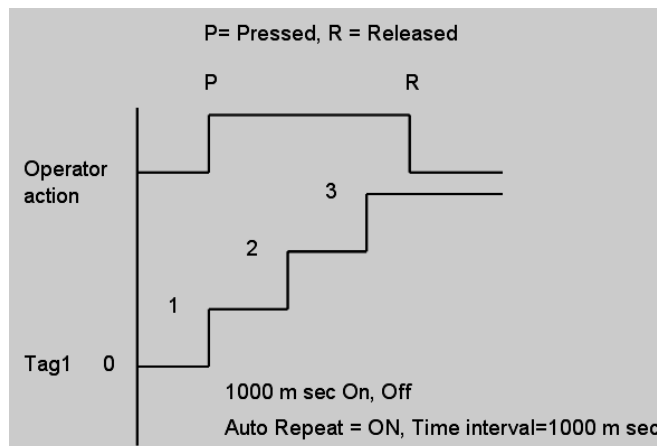

Auto repeat with time interval and holding time cannot be used together.

Tag binding: Select the tag that should be linked to the button to show a different display during run time based on configuration available at Band editor. Any of the configured Analog or Digital tags can be selected.

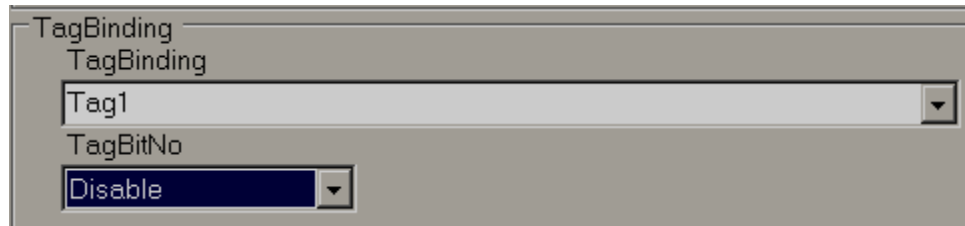

If Tag1 is an Analog Type (32 bit), it is also possible to show a different display based on individual bits. By default, it is disabled. You can select the bit from the combo box and then configure the band editor per project requirements.

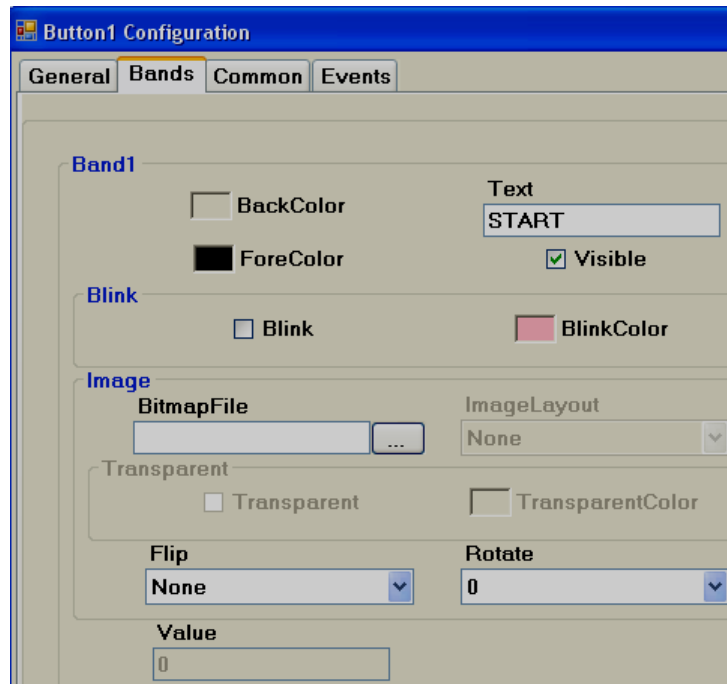

Bands: Defines bands for the button.

Back color: Defines the back color for the selected band

Fore color: Defines the fore color to appear for selected band in run time

Text: Define the text to be displayed for selected band in run time

Visible: Controls if the button is visible

Blink: Select if blink is required when the tag value reaches a selected band during run time. If yes is selected, it allows the user to enter a blink color.

Bitmap file: Select the image to be displayed on button when tag value reaches this band in run time.

For example, When Tag1 = 0, show Red coloured motor symbol on the button. When Tag1 = 1, show Green coloured motor symbol on the button.

Note: Two different symbols are required for the above example

Bmp, wmf, jpg, gif and png types are supported. If the selected file is different than wmf, then, it is also possible to select Image layout and transparent options.

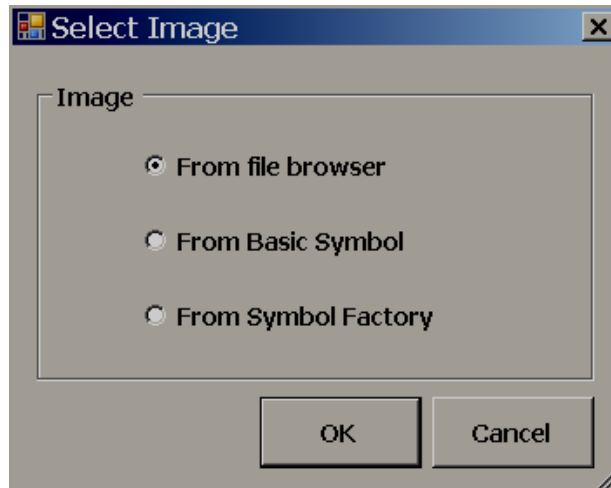

From File browser: To select image from a specified location

From Basic Symbol: To select images from the free basic symbols (*.wmf format) available in Recorder editing software.

From symbol factory: It allows the user to select symbols from the symbol factory (in wmf format).

Image layout: None, center and Stretch options are available. Stretch means the selected bitmap will be stretched to the size of the button.

Note: If a bitmap has poor resolution, when stretch is used, it may show a low quality image in screen.

Flip: Used to flip a button. This needs to be configured during design time. Available options include None, Horizontal, Vertical and Both.

Rotation: Used to rotate the button at predefined angles. This needs to be configured during design time. Available options include 0°, 90°, 180° and 270°.

Value: Defines the maximum range of the selected band. Low range will be the value defined at the previous band. There is no need to enter any value for band 1 as its value is 0 which is low range.



If the button is linked with a Digital Tag, then, in the band editor, it will show only two bands for value 0 and 1. When a button is linked with an Analog tag, it is possible to configure up to 32 bands for showing different states of button based on value of tag. It shows statuses similar to word lamp.

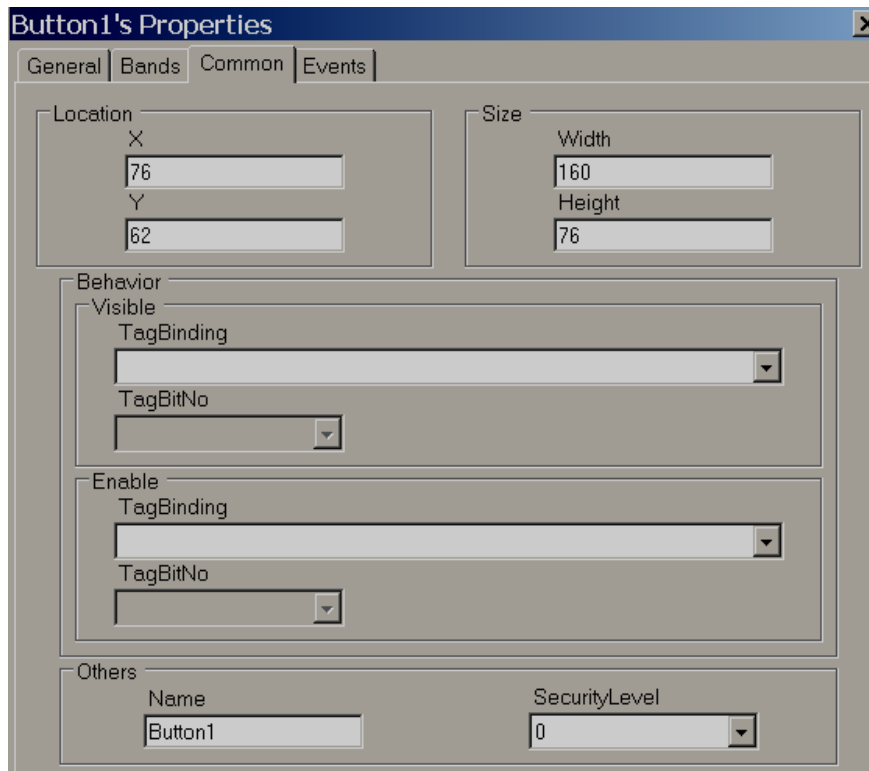

Security control: Defines security level for the button. It allows the user to operate the button only when operator security level is equal to or more than security level defined here. Please refer section “Security” at Project explorer for more information about security features.

Events

Clicked: Define the action that happens when user presses button during Run time. If required, it is possible to configure a holding time for this action.



Holding time is a very useful function. If the PLC has a large scan time, sometimes the operator “clicked” action will be not detected by the PLC. In this case, it is possible to have a hold time for a “clicked” event so that operator action will be continuously present for the time defined at “holding”, such that the PLC will receive the operator action properly.



If the operator touches a button and releases his/her finger instantly, it is called a “Clicked” action. During this time, a total of three actions will be executed. Click, Pressed and Released

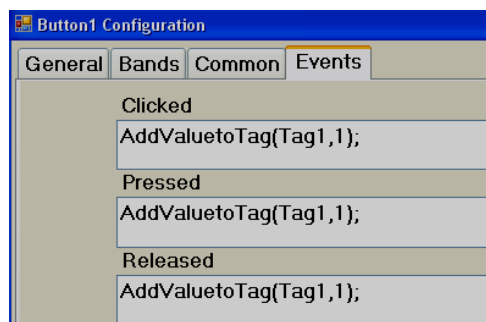

Case-1

Holding time = 0

In above example, Tag1 value becomes 3

Case-2

Holding time = 5000m sec

In the above example, if the scan time for Tag1 is 1000m sec, the Tag1 value becomes approximately 8. When the button is clicked, the “Clicked” and “Pressed” event action occurs, and the Tag1 value becomes 2. Since the holding time is 5 sec, for the next 5 seconds, the Tag1 value is incremented by 1 each second. So, Tag1 value becomes 7. When the button is released, Tag1 value is incremented by 1 again, so it becomes 8. The above example is for illustration only to understand about events for the button object.

Pressed: Define the action that happens when a user continuously presses on a button. If required, it is possible to configure Auto repeat and interval time for this action.



Once an operator touches a button, the “clicked” event will be executed first. If the operator keeps holding the button continuously, the “pressed” action will continuously be executed. When the operator releases their finger, the “released” action will be executed.

Auto repeat: On, Time interval = 1000 m sec. In this example, the Tag1 value will first increment by 1, then it will keep incrementing by 1 once every 1000msec. as long as the operator presses the button. The Tag1 value will also be incremented by 1 when the operator releases the button.

Released: Defines the action when the user releases the button

Switch Function

With this function, two buttons are required. One button to turn a tag ON, and a second button to turn a tag OFF.

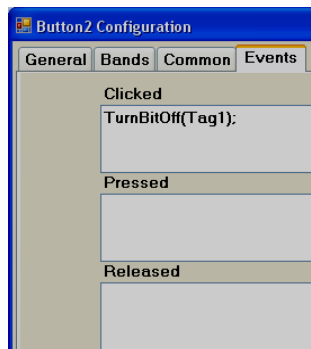
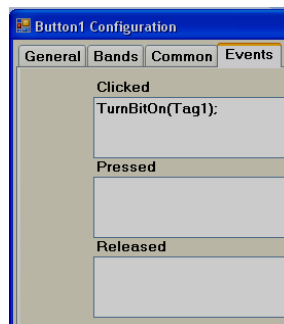

When the operator clicks Button1, Tag1 will = 1. Now, Tag1 will = 1 even after the operator releases the button, and it will continue to maintain its earlier state. When the operator clicks Button2, Tag1 will = 0.

6.3.9.1.16 Bit lamp

A bit lamp is used to show the digital input status for the operator. It is linked with either a digital input tag or an Analog input tag. By using the band editor, it is possible to display a different foreground color, different background color, different text, different symbols, different Blink color, and control visibility when the Tag value is 0 or 1.

When a Bit lamp is linked with a digital tag, it has only two bands by default. The Band1 value is 0 and Band 2 value is 1.

For example: If Tag1 = 0, show Red coloured background with an Orchid color blink. If Tag9 = 1, show green coloured background.



GUI Wizard

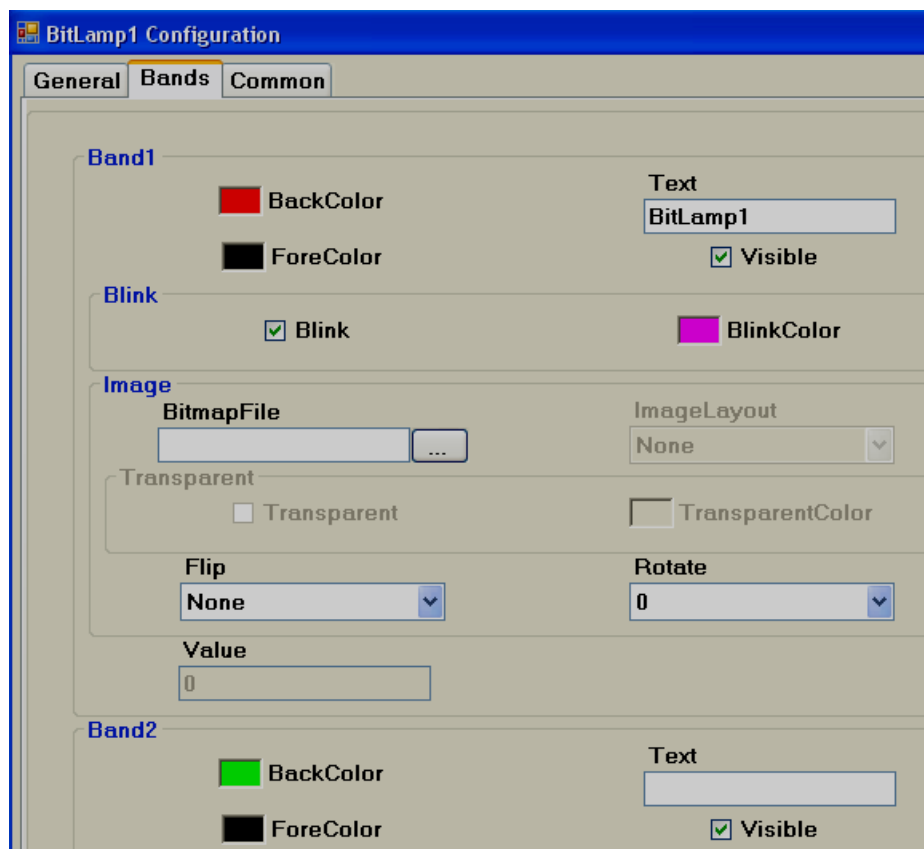
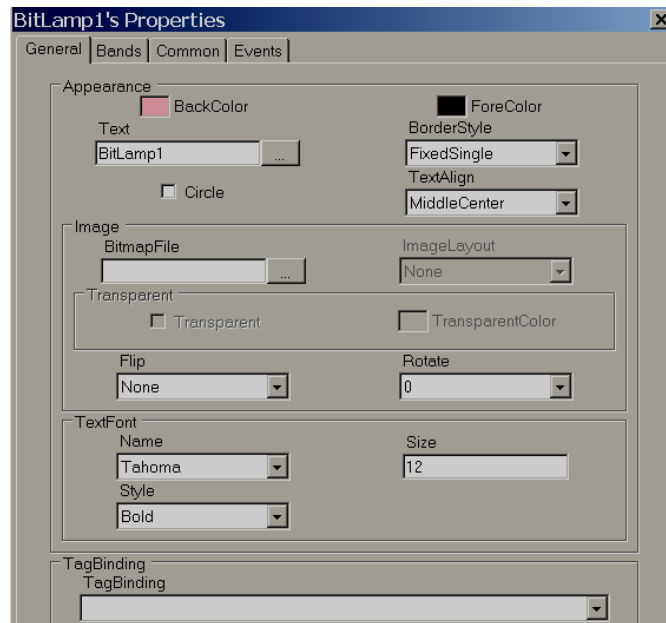

Bitmap file: Select the image to be displayed when tag value reaches this band in run time.

For example: When Tag1 = 0, show Red coloured motor symbol. When Tag1 = 1, show Green coloured motor symbol

Note: Two different symbols are required for the above
Bmp, wmf, jpg, gif and png types are supported. If the selected file is other than wmf, then it is also possible to select Image layout and transparent options.

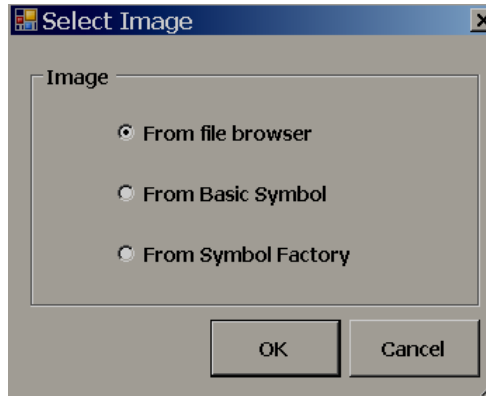

From File browser: Allows user to select images in formats of bmp, wmf, jpg, gif and png

From Basic Symbol: Allows user to select wmf format images from basic symbols

From symbol factory: Allows for selecting symbols from symbol factory in .wmf format

Image layout: None, center and Stretch options are available. Stretch means the selected bitmap will be fixed to the size of the bit lamp

Note: If a bitmap has poor resolution, when stretch is used, it may show a low quality image in screen.

Flip: Used to flip bit lamp and needs to be configured during design time. Available options include None, Horizontal, Vertical and Both.

Rotation: Used to rotate a bit lamp in predefined angles and needs to be configured at design time. Available options include 0°, 90°, 180° and 270°

Circle: By default, a bit lamp object shape is in Rectangle. Select this if you wish to change the bit lamp shape to a circle. It is more useful to show status of digital inputs for the operator during Run time.

How to show status of an individual bit in Analog type tag

Sometimes, you will get a 16 bit/32 bit tag from a PLC with different diagnostic information, and you would like to show 16 bit/32 bit lamps in the Recorder screen.

When a Bit lamp is linked with an Analog tag, for example: Int16/Int32, it has two bands. By default, Band1 value is 0 and Band 2 value is 1. In this case, using each bit lamp, it is possible to show the status of each individual bit status within 32 bits as per configuration available at band editor.

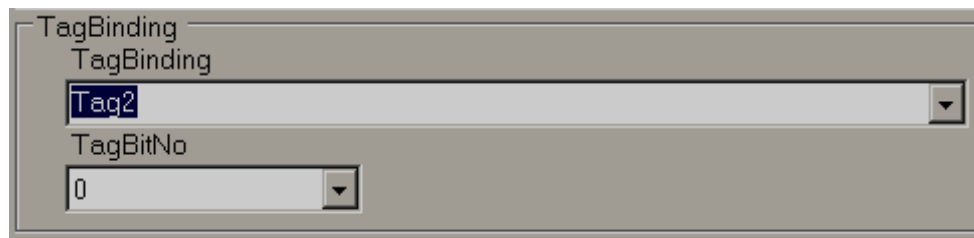

In the above figure, Tag2 is an analog type (4 byte), so, a TagBitNo combo box will appear for the selection of the required bit within 32 bits (0 to 31).

If Tag2 is Digital type tag, then, TagBitNo. Combo box is not visible.

6.3.9.1.17 Word lamp



Word lamps are similar to Bit lamps but linked with an Analog type tag only. It can have many bands. By using the band editor, it is possible to display a different foreground color, different background color, different text, different symbols, different Blink color, and control visibility when Tag values change values during Run Time.

For example: Tank Level indicator

When Tag1 value is

0 to 10, Text = Low Low Level, Color = Yellow Blinking

11 to 20, Text = Low Level, Color = Yellow Background

21 to 80, Text = Normal, Color = Green back ground

81 to 90, Text = High level, Color = Red back ground

91 to 100, Text = High High Level, Color = Red blinking

Create 5 bands as shown

GUI Wizard/Dialog

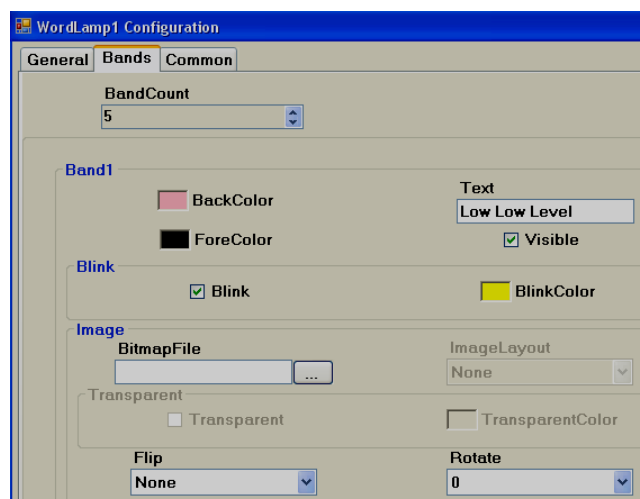
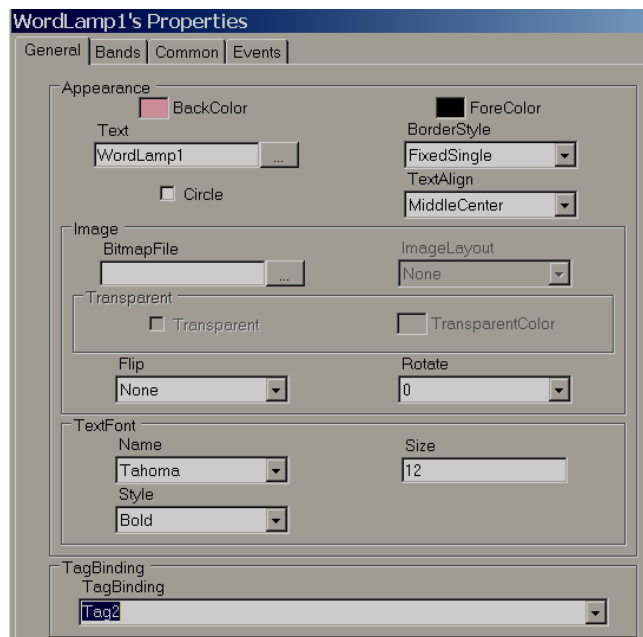

Band1 range = 0 to value defined at band2-1. i.e., 0 to 10

The screenshot shows the configuration for Band2. It includes a BackColor (yellow) and ForeColor (black) section. The Text field is set to 'Low Level' and the Visible checkbox is checked. Under the Blink section, the Blink checkbox is unchecked and the BlinkColor is pink. The Image section includes a BitmapFile field with a browse button, an ImageLayout dropdown set to 'None', and a Transparent section with an unchecked checkbox and a TransparentColor field. The Flip dropdown is set to 'None' and the Rotate dropdown is set to '0'. The Value field at the bottom contains the number '11'.

Band2 range: Band 2 value to Band3 value-1 i.e., 11 to 20

The screenshot shows the configuration for Band3. It includes a BackColor (green) and ForeColor (black) section. The Text field is set to 'Normal' and the Visible checkbox is checked. Under the Blink section, the Blink checkbox is unchecked and the BlinkColor is pink. The Image section includes a BitmapFile field with a browse button, an ImageLayout dropdown set to 'None', and a Transparent section with an unchecked checkbox and a TransparentColor field. The Flip dropdown is set to 'None' and the Rotate dropdown is set to '0'. The Value field at the bottom contains the number '21'.

Band3 range: Band 3 value to Band4 value-1 i.e., 21 to 80

The screenshot shows the configuration for Band4. It includes a BackColor (red) and ForeColor (black) section. The Text field is set to 'High Level' and the Visible checkbox is checked. Under the Blink section, the Blink checkbox is unchecked and the BlinkColor is pink. The Image section includes a BitmapFile field with a browse button, an ImageLayout dropdown set to 'None', and a Transparent section with an unchecked checkbox and a TransparentColor field. The Flip dropdown is set to 'None' and the Rotate dropdown is set to '0'. The Value field at the bottom contains the number '81'.

Band4 range: Band 4 value to Band5 value-1 i.e., 81 to 90

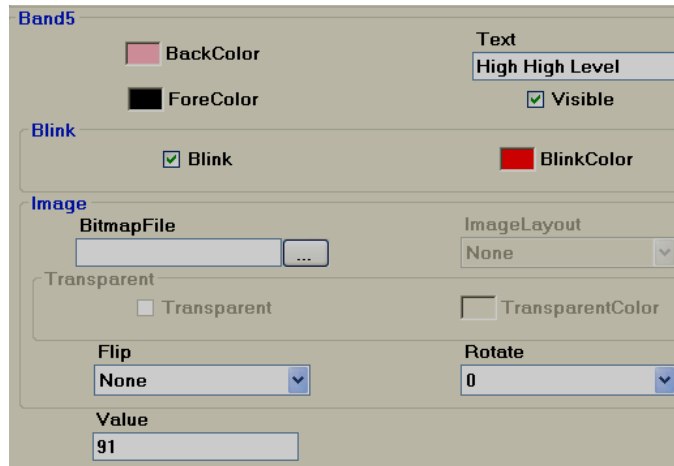

Band5 range: More than or equal to value defined at band 5 (In this case number of bands = 5) i.e., greater than 91

6.3.9.1.18 Check Box

The Check box (or tick box) is a graphical user interface widget that permits the user to make multiple selections from a number of options during run time.



Every check box is linked with a single **Digital** tag from Tag Database. In the above white box, normally, white space means Not selected, False, Tag Value = 0 Tick mark means, True, Tag value = 1

A caption describing the meaning of the check box is normally shown adjacent to the check box. Inverting the state of a check box is done by touching with a finger or clicking the mouse on the box, or on the caption.

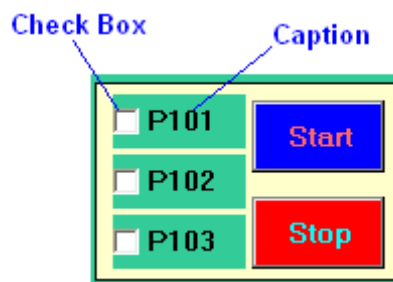

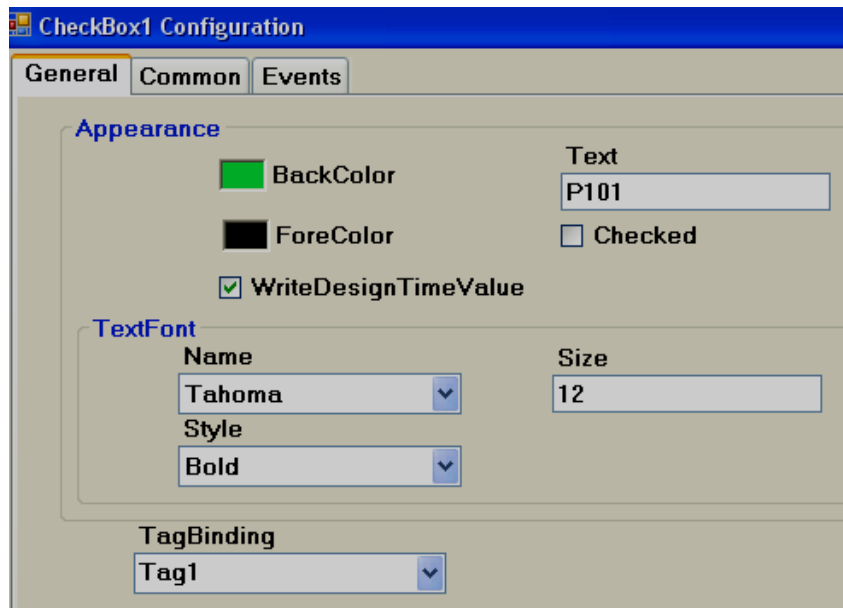

Properties

Write design time value: If selected, it overwrites the default value defined in the tag database.

Checked: Default setting, available options True/False

For example: Tag1 is linked with Checkbox 1. If Checked, the tag = False, that means Tag1 = 0. If Checked, the tag = True, then Tag1 = 1.

Text: It is Text that appears near Check box as a caption. Example: Text = P101

Events

Changed: Define action using function editor. When operator presses on check box during Run time, the actions defined here will be executed.

Example: There are three pumps named P101, P102 and P103, and the operator would like to select pump P101 for start-up. Using the check box, write a meaningful caption via the "TEXT" property to appear at the right side of check box, and link each of the above check boxes with appropriate Tags. Let's say P101, P102 and P103. Then, when P101 is selected by the operator in run time, P101 Tag value will become 1.



If "checked" = false is selected during design time, then Tag value will = 0. If operator presses on check box during Run time, the symbol ✓ will appear, and **the** Tag value will become 1.

If "checked" = True is selected during design time, the Tag value will = 1, and the ✓ appears during Run time. If the operator presses the check box during design time, the symbol ✓ disappears and the Tag value becomes 0.



If you are unable to select the required selection using check box in Run time, please perform touch screen calibration.



If Check box is linked with an Analog type Tag, then, it is possible to select an individual bit.

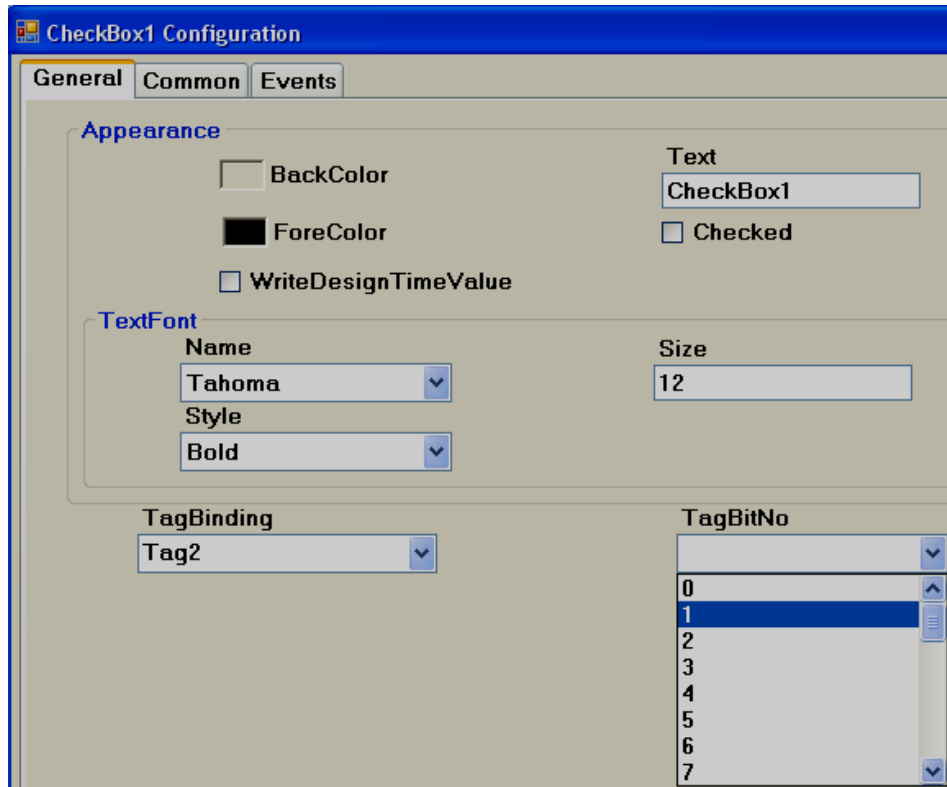

6.3.9.1.19 Combo box



A combo box is a commonly-used graphical user interface widget. It is a combination of a drop-down list or list box and a single-line text box, allowing the user to choose from the list of existing options in Run time. Generally it is linked with an Analog tag. Based on selection, the value of the tag will be changed, and it can be used in Logic at PLC.

It saves space in the Recorder screen by allowing the operator to select the option only when it is required by touching the down arrow at right side of Combo box.

Every Combo box is linked with single **Analog** tag from properties.

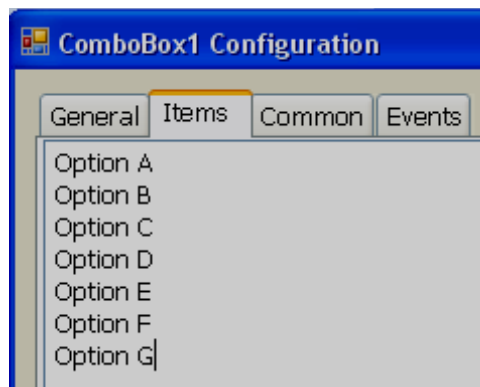
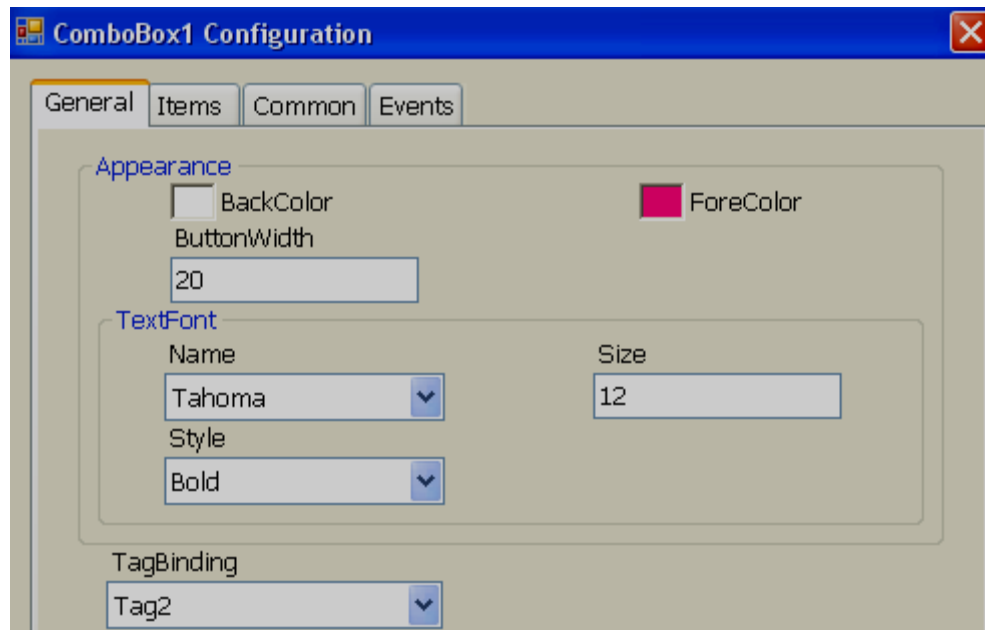

Note: Do not keep any empty space between different text entries, otherwise, unpredictable results may occur.

Property grid

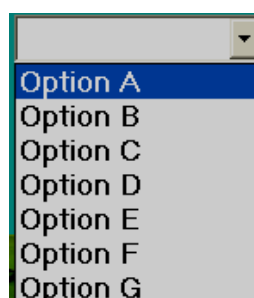
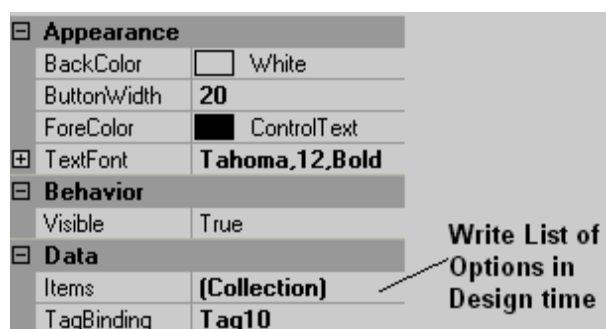

Design	
(Name)	ComboBox1
Locked	False
SecurityLevel	0
Events	
Changed	
Layout	
Dock	None
Location	128, 96
Size	224, 24

Properties

Button Width: Defines the width of a Button. It modifies the width of the down arrow at the right side of the combo button.

Items: Defines all the available options during design time.

For example: There are 7 options available to select a process. Tag1, analog tag, is linked to Combo box1. Now, If Option A is selected, then during Run time, Tag1 value will = 0, If Option B is selected, then Tag1 value will = 1. If Option G is selected, then Tag1 value will = 6.

Events

Changed: Defines an action using function editor. When the operator presses on a combo box



To increase up/down arrow size on combo box, increase the size of text font.

6.3.9.1.20 List box



A list box is a Graphical User Interface widget that allows the user to select a single item from a list of available items. The available options are entered during Design time and they are available for selection during Run Time. On selection, it writes a value to a Tag based on the order number. Every List Box should be linked with an **Analog** tag.

GUI Wizard/dialog

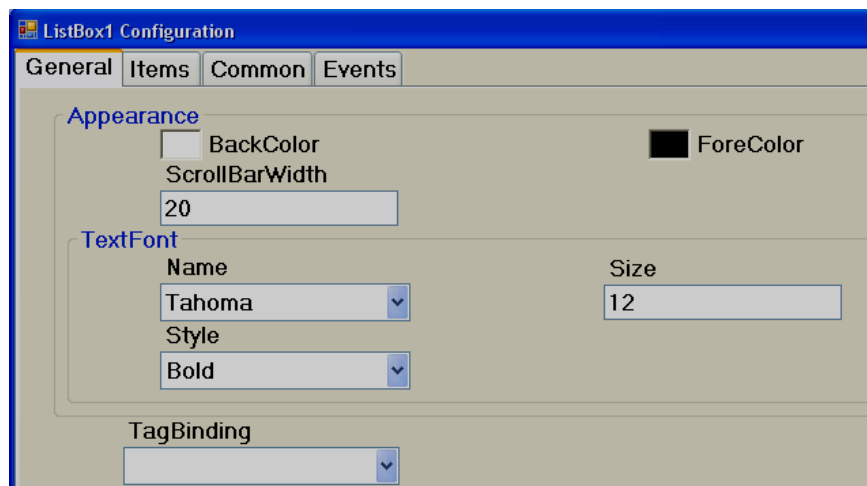

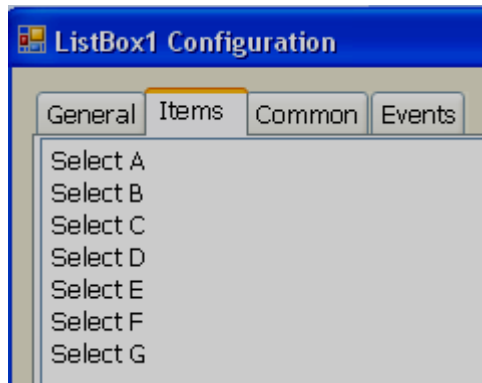

Note: Do not keep any empty space between different text entries, otherwise, unpredictable results may occur.

Property Grid

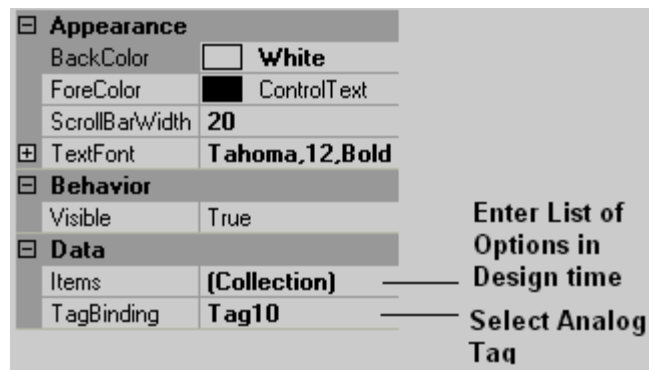

Design	
(Name)	ListBox1
Locked	False
SecurityLevel	0
Events	
Changed	
Layout	
Dock	None
Location	176, 128
Size	160, 112

Properties

Scroll Bar Width: Defines the width of the scroll bar that appears on Right side of List box.

Items: Define all the available options in design time.

For example: There are 6 options available to select a process. Tag1, an analog tag, is linked to List box1. Now, if “Select A” is selected, then Tag1 value will = 0. If “Select B” is selected, then Tag1 value will = 1. If “Option G” is selected, then Tag1 value will = 5.

Events

Changed: Define actions using function editor. When operator presses on list box item in Run time, the actions defined here will be executed.

6.3.9.1.21 Group Panel

Used to group objects in a screen.

Procedure

- ✧ Click on “Group Panel” at Basic Objects
- ✧ On Screen, just draw a rectangle with your mouse over the objects that you would like to group together. It will appear as shown below:

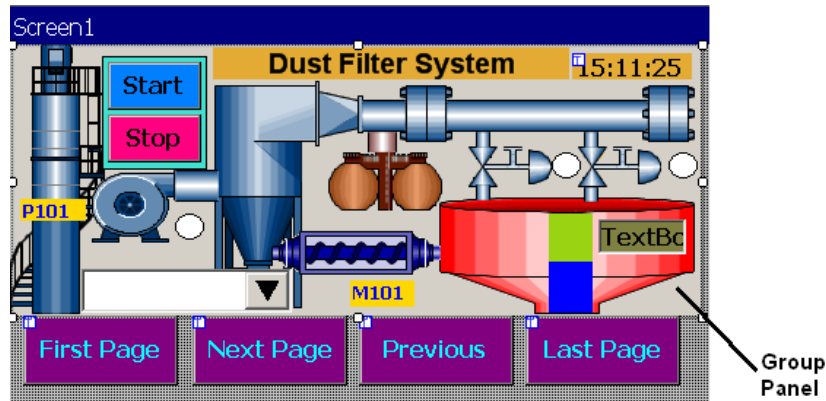

✧ Now, double click on Group Panel object

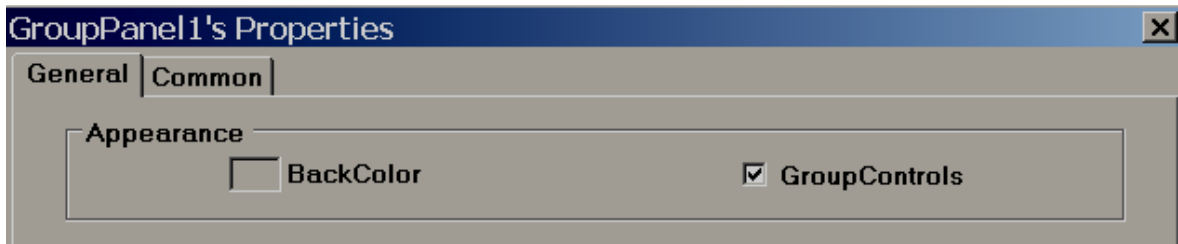

✧ Select "Group Controls" check box and click "OK"
 Now, you will be able to move grouped objects to another location, or rescale them to fit to another screen size etc.
Group Controls: Select the check box to apply the group function. De-select the check box for ungroup

6.3.9.2 Enhanced Objects

Fine components are available for User interface and display. The components include Dial, Digital LED, Level, Meter, Slider, Switch, Thermometer and Toggle.

6.3.9.2.1 Common Properties

Appearance

Back Color: Set the background color of the component.

Bevel: Used to set border including inner border, outer border and style of border.

Inner Border: True/False

Outer Border: True/False

Style: 9 styles are available

None, Flat, Single, Double, Raised, Lowered, Double Raised, Double lowered, Frame Raised, Frame Lowered.

Behaviour

Visible: True/False. Determines whether control is visible or hidden.

Enable: This is for event control. If linked with a Digital tag, if the tag value = 1 during run time, events configured for the object will be executed. If tag value = 0, events will be not executed.

Data

Tag Binding: Select the Analog Tag of process value

Write design time value: If selected, the value entered here during design time will be replaced by the default value defined in the tag data base.

Design

Name: Label1, It is the name of the component. Every component will have a **UNIQUE** number in a page. If more than one Label is available in the same page, the number will be incremented automatically. The user can also change name of this component if required. Component "Name" property is very useful and it can be used in scripts also.

Example: Task: Change Label1 "back" color to blue during Run time when Tag1 is equal to 1.

```
If (Tag1 == 1)
{
Screen1.Label1.BackColor=Color. Blue;
}
```

Screen1: It is the location of Label1

Label1: Object name

BackColor: Property of Label related to background color

Color.Blue: Target Color

If the above script is executed in scheduler once per second, then when Tag1 = 1, the back color for Label1 will change to Blue during Run time.



Properties are case sensitive.

BackColor: OK

Backcolor: Not OK

Security Level: Define security level for the component to be used by the operator. If operator security level is less than security level defined for component, it will not allow operator to operate the component.

Locked: True/False: It is to Move or Resize the component.

Layout

Dock: Defines which borders of the control are bound to the container.

Location: The coordinates of the upper-left corner of the component relative to upper-left corner of the container. Set X and Y position in screen in pixels.

Size: Size of the component in pixel. Set height and width of component in pixels.

Position: It is the defined position of Label, Value etc., for some components. Available options include None, Top Left, Bottom Right, Both and Internal.



Position naming convention for components

For example: Level component, Label Position = **Bottom Right**

If Orientation is Vertical, the Label will be displayed on the **Right** side of the component.

If Orientation is Horizontal, the Label will be displayed on the **Bottom** side of the component.

6.3.9.2.2 Level

Levels are normally used to display a process parameter value in several steps. Generally it is linked with Analog type tag (Analog input type tag at PLC, which is received as 4-20 mA signal from field transmitters like Ear level transmitters (sound detectors in ball mills, etc.).

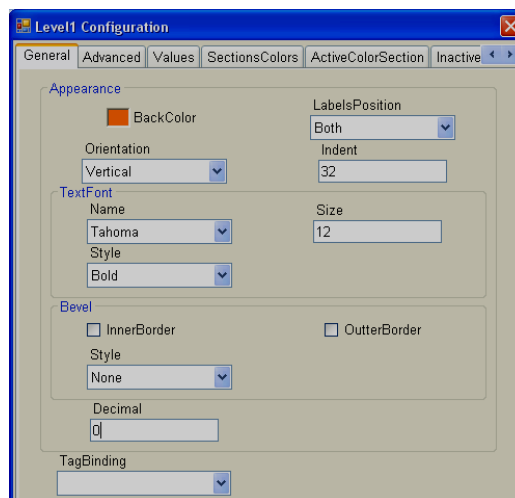
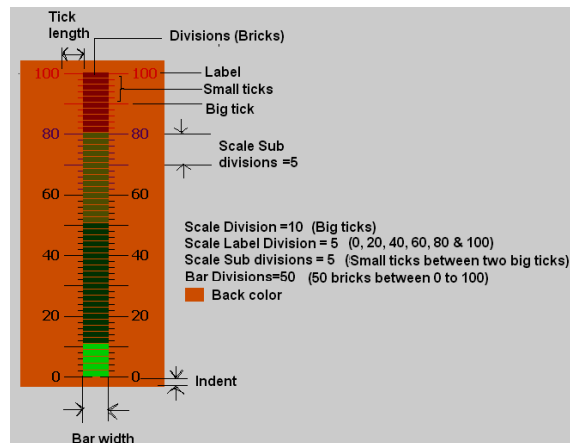

Properties

Back Color: Defines the background color for the component.

Labels Position: Define label position. Available options are Top Left, Bottom Right and Both. Naming convention depends on orientation. If orientation = Vertical, then, if "Top left" is selected, label position will be shown on "Left" side. If orientation = Horizontal, then if "Top Left" is selected, label position will be shown on "Top" side of component.

Orientation: Vertical/Horizontal. Select direction.

Text Font: Used to set the font of the label. Options include Name of Font, Size of font and Style of font. Supported styles include Regular, Bold, Italic, Underline & Strikeout.

Bevel: Defines inner border and outer border for the component. Please refer to common properties at the beginning of this section for more details.

Decimals: Define number of decimals to be displayed for value to be displayed along with level component in run time.

Tag Binding: Selects the Analog Tag of process value.

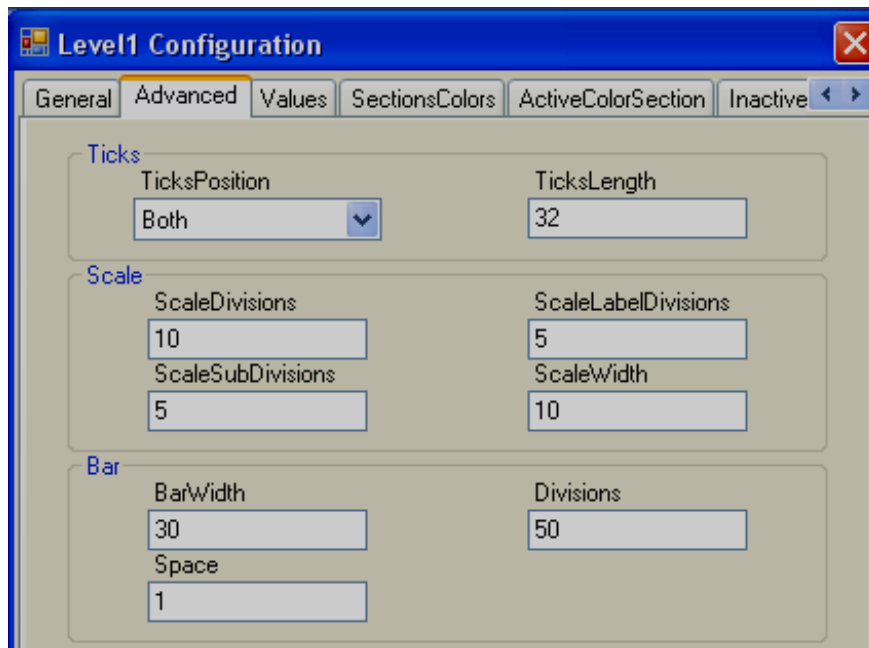

Ticks:

Ticks Position: Define Ticks Position. Available options include Top Left, Bottom Right, Both and None.

Ticks length: Define length of Ticks in pixels.

Scale:

Scale divisions: Define the number of Big Ticks in Level graph.

Scale Sub Divisions: Define the number of ticks between two big ticks.

Scale Label Divisions: Define the number of Labels to be displayed. Example: If Scale label division = 5, Scale = 0-100, then, it display labels as 0, 20, 40, 60, 80 & 100.

Scale Width: Define Scale width. If ticks are selected to display on both directions, this is the defined width between two scales on both sides.

Bar

Bar Width: Define width of Bar graph.

Divisions: Define number of divisions (Like bricks) to appear in Bar graph.

Space: Define Space between divisions (bricks) in pixels.

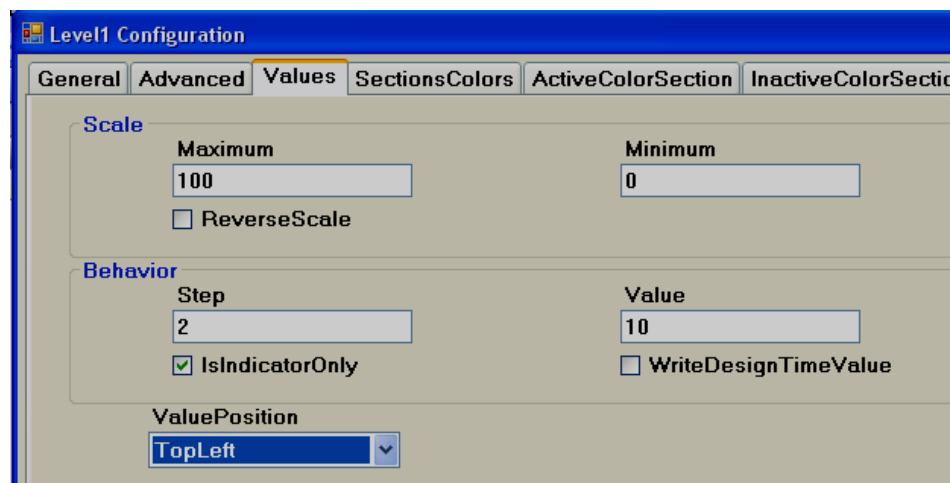

Maximum: This is the max range of the process value (analog input tag)

Minimum: This is the minimum range of Process Value (analog input tag)

Example: If an Ear Level transmitter range is 0 to 100, set Minimum = 0, Maximum = 100.

Reverse Scale: True/False. If it is selected, then, zero will be on bottom side and 100 will be at top side for vertical orientation.

Step: This is the minimum value to reflect change in Bar graph position. Bar Step and Bar division settings are closely related. If Bar divisions = 50 for a scale value of 0-100, then, if Step=2, when process value changes by value 2, it shows level value change clearly in level graph.

Value: Used to enter a process value during design time and to check the bar graph display on the PC. It requires the operator to enter a value in multiples of the step value.

Otherwise, it is automatically rounded to the closest multiple of the step value.

Is Indicator only: If this is selected, the level graph is used for "Read" purposes only. If it is not selected, you can use a level graph for write purposes similar to slider to send a set point from the Recorder to a PLC etc. Just use finger to touch at various places in Level graph to set the level required.

Value Position: Define position of process value to be displayed during Run time along next to the Level graph. Available options include None, Top Left, Bottom Right and Both.

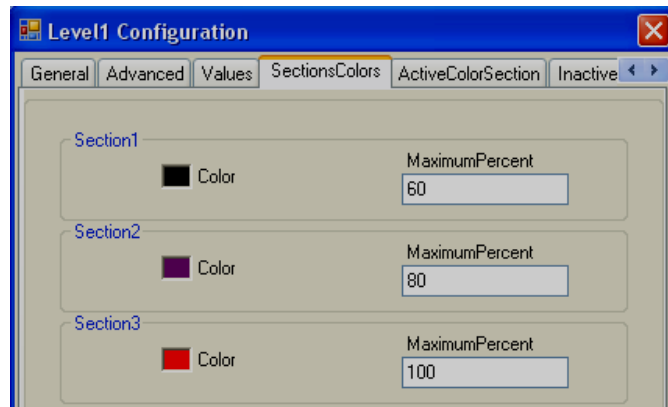

Sections colors: It is configure bands for the sections to show different colors for Labels and Ticks in Level graph.

Example: Three bands

Section 1, Max % = 60 means, its band is from 0 to 60 %, and it will show labels and ticks in black color.

Section 2, Max % = 80 means its band is from 61 to 80 %.

Section 3, Max % = 100 means its band is from 81 to 100 %.

Note: Band setting is in % for the total Scale defined (Minimum to maximum).

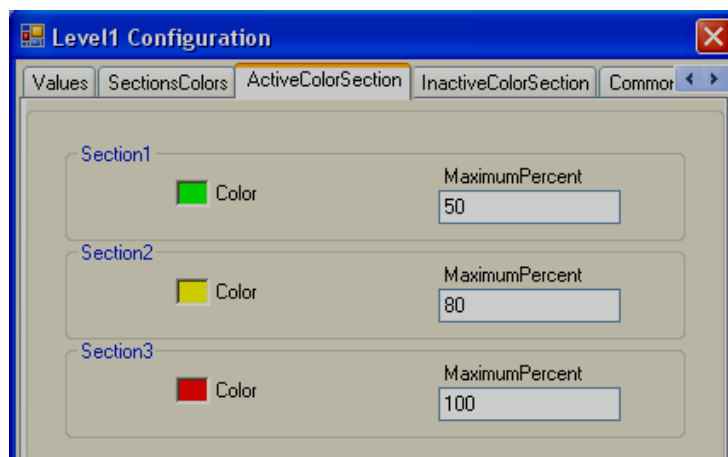

Active Color Section: Defines the active color for the process value band. For example: If a process value range is 0-100, set different bands in % for the process value, and define colors to appear within the level Bar graph during Run Time.

When the process value is between 0 and 50% of scale, display bricks in Lime color.

When the process value is between 51 and 80% of scale, display bricks in Yellow color

When the process value is between 81 and 100% of scale, display bricks in Red color.

Configuration from Property grid

ActiveColorSection	ColorSection[] Array
InactiveColorSection	ColorSection[] Array

Click the "ColorSection Array and the following screen will appear. Then, set all the bands and colors.

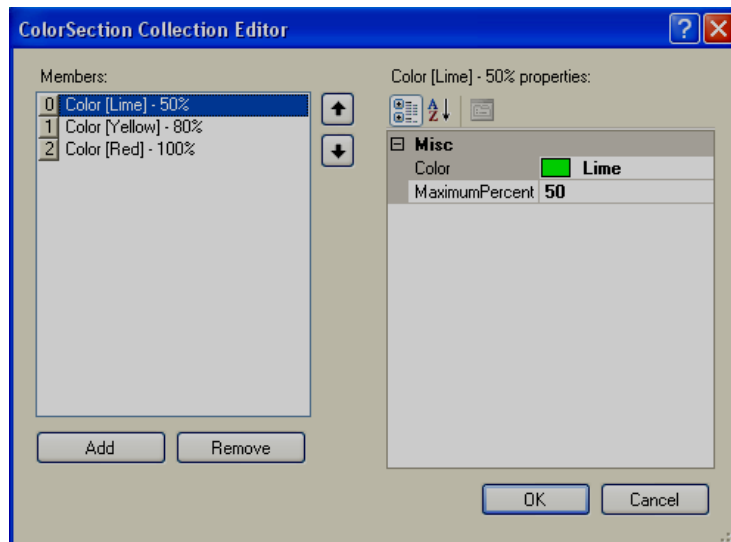

Inactive Color Section: Define Inactive colors for process value bands the same as above. Generally, light colors are selected for Inactive colors and dark colors with more contrast are selected for Active colors. This way, users/operators will be able to differentiate between active and inactive colors easily.

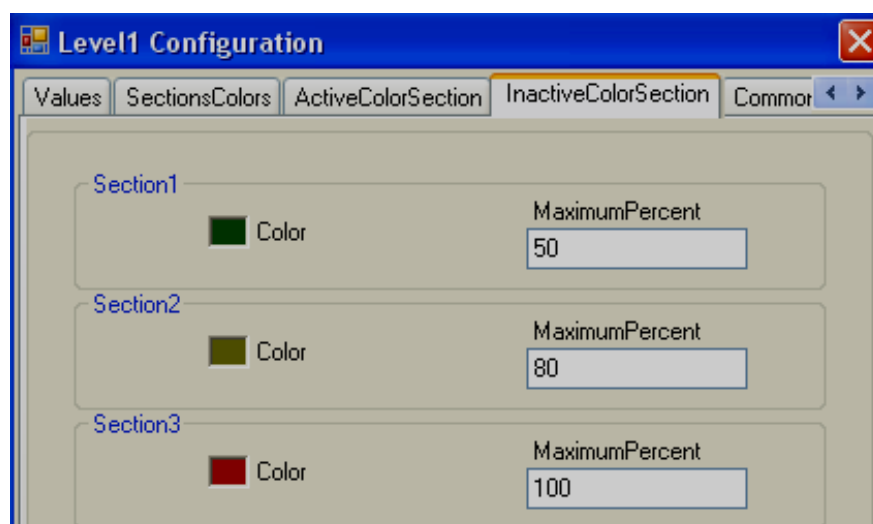

Events: It is to trigger functions/jobs to be executed when process value of tag linked with Level bar graph is changed during run time.

6.3.9.2.3 Meter

A Meter is a component generally used to display process values like Pressure, Temperature, Flow etc. Generally, it is linked with an Analog tag (Analog input type tag at PLC, which is received as 4-20 mA signal from field transmitters like Temperature, pressure, etc.)

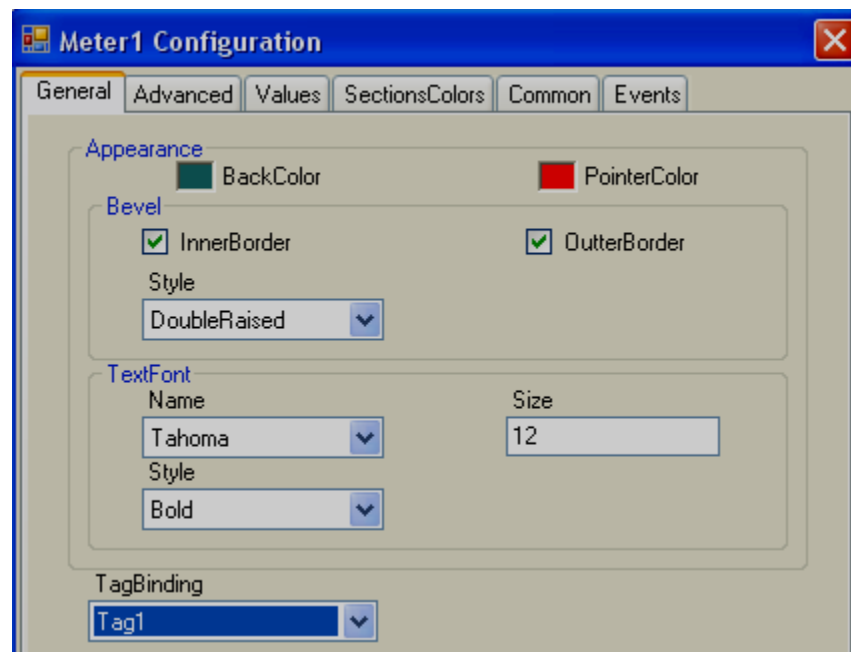
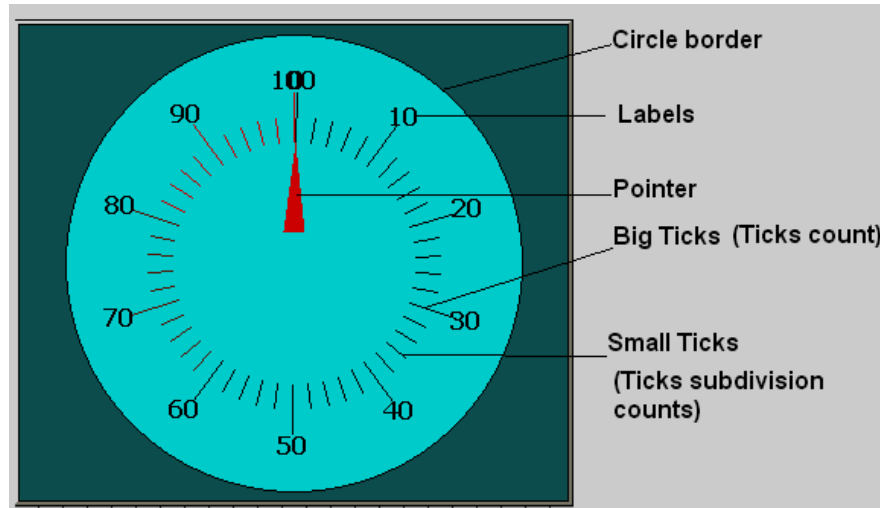

Properties

Back color: It is to set back ground color for the Meter.

Pointer Color: It is to set Pointer Color.

Bevel: It is to set border including inner border, outer border, and style of border.

Inner Border: True/False

Outer Border: True/False

Style: 9 styles are available

None, Flat, Single, Double, Raised, Lowered, Double Raised, Double lowered, Frame Raised, and Frame Lowered.

Text Font: Used to set font for the label including Name of Font, Size of font and Style of font. Supported styles include Regular, Bold, Italic, Underline & Strikeout.

Tag Binding: Select the Analog Tag of process value.

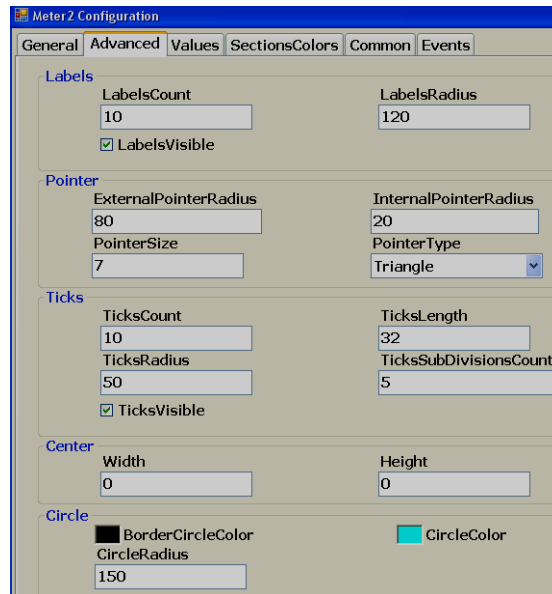

Labels:

LabelsCount: Number of labels to be displayed around the Meter.
Example: Pressure transmitter range 0-100 bar
 Label count = 10 Around the Meter, you will see labels marked with 10, 20, 30, 40, 50, 60, 70, 80, 90 and 100.

LabelsRadius: It is to set the radius of Labels to be displayed around the Meter.

LabelsVisible: True/False, it is to set visibility for the label

Pointer

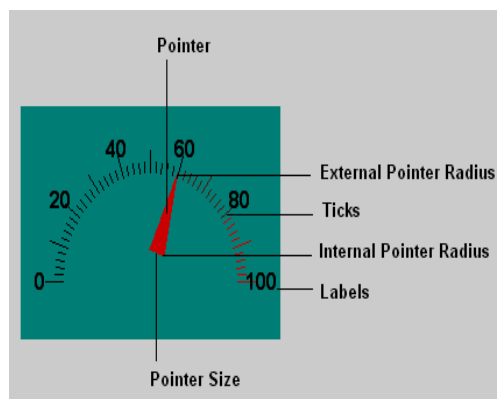

Pointer	
ExternalPointe	80
InternalPointer	20
PointerColor	Red
PointerSize	7
PointerType	Triangle

External Pointer Radius: It is used to set external pointer Radius, define end position.

Internal pointer Radius: It is used to set Internal Pointer Radius, defines start position.

Pointer Size: It is to set Pointer Size in pixels.

Pointer Type: It is set Pointer type. Available types include Triangle, Circle and Line.

Ticks

Ticks Count: Set number of ticks between labels.

Ticks Length: Set Tick length in pixels.

Ticks Radius: Set Tick Radius

Ticks subdivision counts: Set Tick sub division counts

Ticks Visible: True/False, Set Ticks visibility

Center

Width: Adjust width of meter within boundaries.

Height: Adjust height of meter within boundaries. This is useful when a half-circle meter is required. The meter needs to be adjusted to the center as shown below.

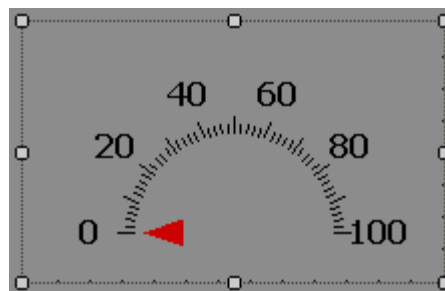

Circles

Border circle Color: Set border color for circle.

Circle Color: Set Color for circle.

Circle Radius: Set Radius for circle.



Note: If Border circle color is the same as the back color, then the circle will not be visible.

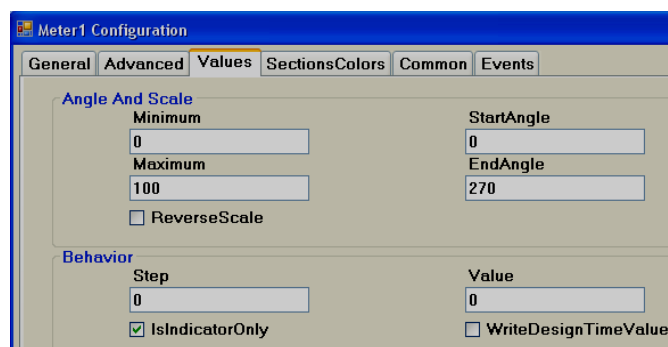
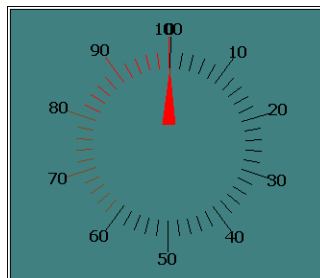

Angles & Scale

Maximum: This is the maximum range of the Process Value (an Analog input Type Tag).

Minimum: This is minimum range of Process Value (Analog input Type Tag).

Example: If pressure transmitter range is 0 to 100 bar, set Minimum = 0, Maximum = 100.

Start Angle: It is the start angle for the Range low (Analog input)

End Angle: It is the end angle for the Range high (Analog input)

Reverse Scale: It is to set scale direction in Meter

False: Anti-Clockwise

True: Clockwise

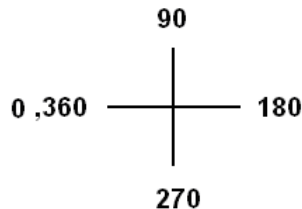

Reverse Scale = True

For example: If you want 0° (Left) to 180° (Right) Meter for Process value range 0-100, set the following.

Start Angle: 0°, End Angle: 180° and Reverse Scale = True.

Behaviour

Step: It is the minimum value to reflect change of pointer position in Meter.

For example: By default, Step = 0, i.e., the pointer moves its position in the Meter in Real time even with a minor change in process value.

For example: Step = 5, i.e., the pointer moves its position on the Meter in Real time in steps of 5.

Value: It is used to enter process value in design time and check pointer position in PC.

Indicator only: By default, it should be selected so that the meter will be used for Read purposes only. If it is not selected, then you can use the Meter for Write purpose similar to a Slider to send a set point from the Recorder to a PLC etc. Just use your finger and move pointer to change set point.

Write design time value: If selected, it writes design time value instead of default value defined at tag data base.

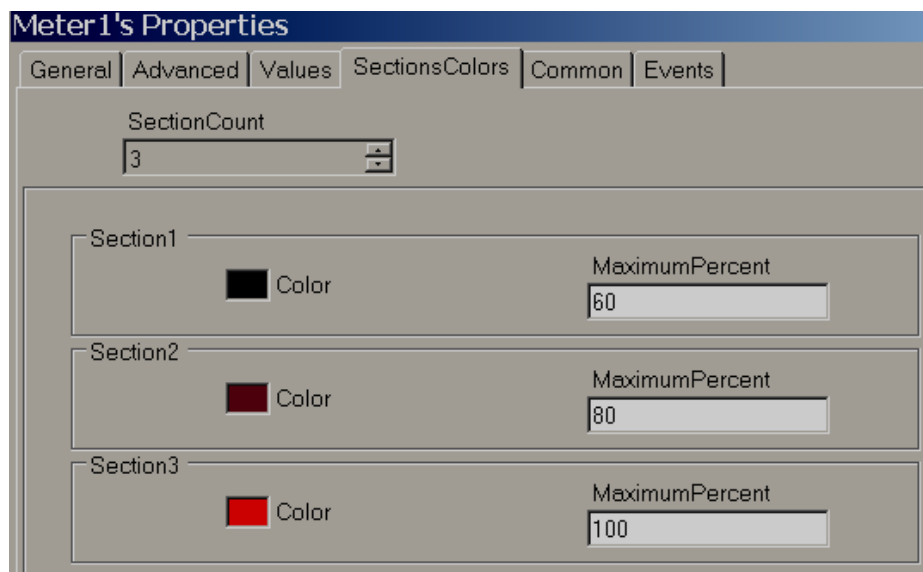

Sections colors

It is to configure bands for the sections to show different colors for Labels and Ticks in Meter.

Example: Three bands

Section 1, Max % = 60. That means its band is from 0 to 60%. It shows labels and ticks in black color.

Section 2, Max% = 80 that means, its band is from 61 to 80%.

Section 3, Max% = 100 that means, its band is from 81 to 100%.

Note: Band setting is in % for the total Scale defined (Minimum to maximum).

6.3.9.2.4 Slider

This is normally used to change the set point of a process by the operator from the Recorder during Run time. Generally, it is linked with an analog tag (analog output type tag at PLC, to send 4-20 mA signal out from PLC to external Controllers, Variable speed drives, etc.).

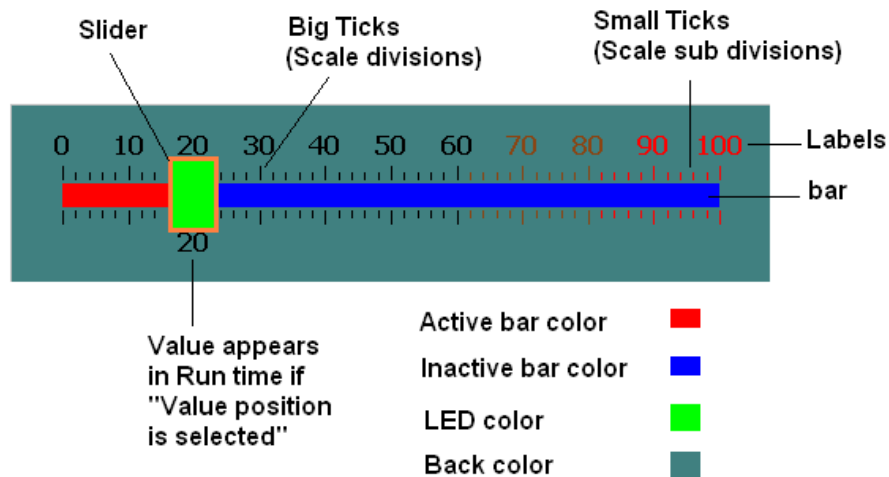

In the above figure, Scale divisions = 10 (Big ticks). Scale sub divisions = 5 (Small ticks between big ticks). Scale Label divisions = 10 (0, 10, 20 till 100).

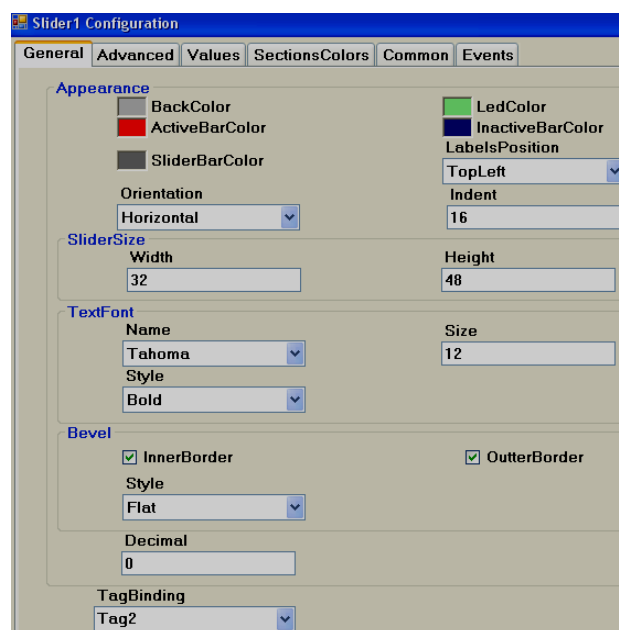

Properties

Back color: Back color for the component.

Active bar color: Define active bar color.

Slider bar color: Define border color for the slider.

LED color: Color of the handle

Inactive bar color: Define inactive bar color.

LabelsPosition: Define Label position. Available options include Top Left, Bottom Right, Both, Internal and None.

Orientation: Horizontal/Vertical. This is the orientation of the slider component. In the above figure, it is in the Horizontal position.

Slide size: Define height and width of the slider.

Text Font: It is to set the font for the label including Name of Font, Size of font and Style of font. Supported styles include Regular, Bold, Italic, Underline & Strikeout.

Bevel: It is to set a border including inner border, outer border and style of border.

Inner Border: True/False

Outer Border: True/False

Style: 9 styles are available

None, Flat, Single, Double, Raised, Lowered, Double Raised, Double lowered, Frame Raised, and Frame Lowered.

Tag Binding: Select the Analog Tag of a process value.

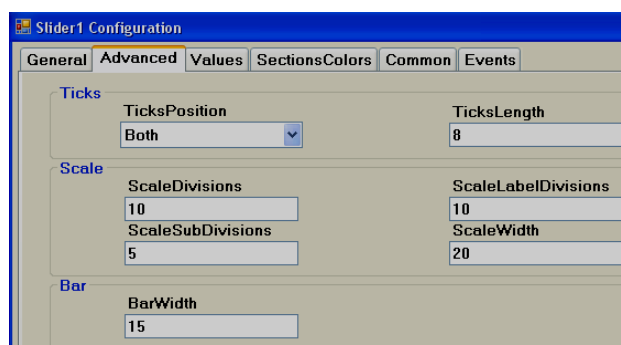

Ticks:

Ticks Position: Define ticks position. Available options include Top Left, Bottom Right, Both, Internal and None.

Ticks Length: Set Tick length in pixels

Scale:

Scale divisions: Define number of Scale divisions (Big ticks).

Scale Sub Divisions: Define number of Sub divisions (Small Ticks between big ticks).

Scale Label Divisions: Define number of Labels to appear. Ex. 0, 10, 20 etc. till 100 for scale 0 to 100.



Define same value for both Scale divisions and Scale label divisions.

Scale Width: Define Scale width.

Note: This is only the width for Scale divisions. Example: If ticks position is selected on both sides, then it is the gap between two scale ticks (Top and Bottom in Horizontal orientation or Left and Right in vertical orientation).

Bar:

Bar Width: Define width of Bar.

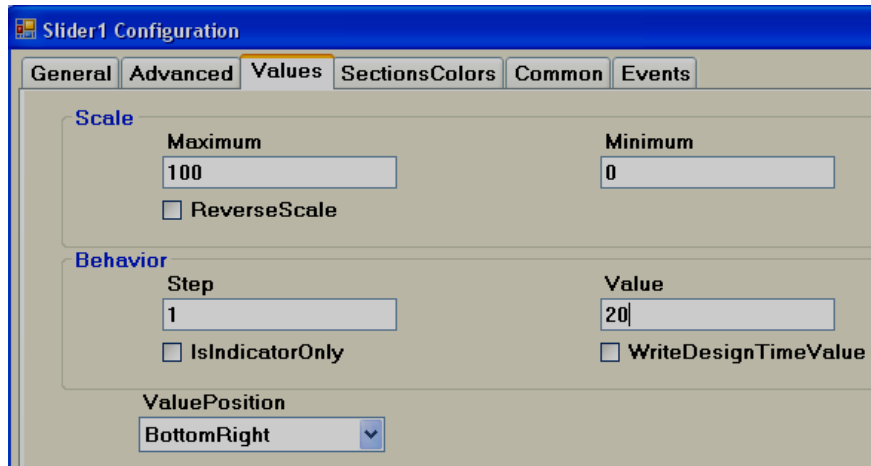

Scale:

Maximum: This is maximum range of Set point (Analog Tag, Normally Analog Output).

Minimum: This is minimum range of Set Point (Analog Tag, Normally Analog Output).

Example: If Controller set point is 0 to 100°C, set Minimum = 0, Maximum = 100.

Reverse Scale: If Selected, Scale labels will be displayed in Reverse.

Behaviour:

Step: It is the minimum value change when the slider is moved.

For example: By default, Step = 0, i.e., Slider moves its position in Real time even with minor change in process value.

For example: If Step = 5, Slider moves its position in Real time in steps of 5.

Value: It is used to enter process value in design time and check the Slider position in PC.

Indicator only: If Indicator only is selected, slider is used for Read only. Operator will be not able to move slider in Run time. If Indicator only is not selected, the slider is used for Read/Write. Operator will be able to move slider in Run time for example: change set point for variable speed drive.

Value Position: Define position for the value to appear during Run time. Available options include Top left, Bottom Right, Both, Internal and None.

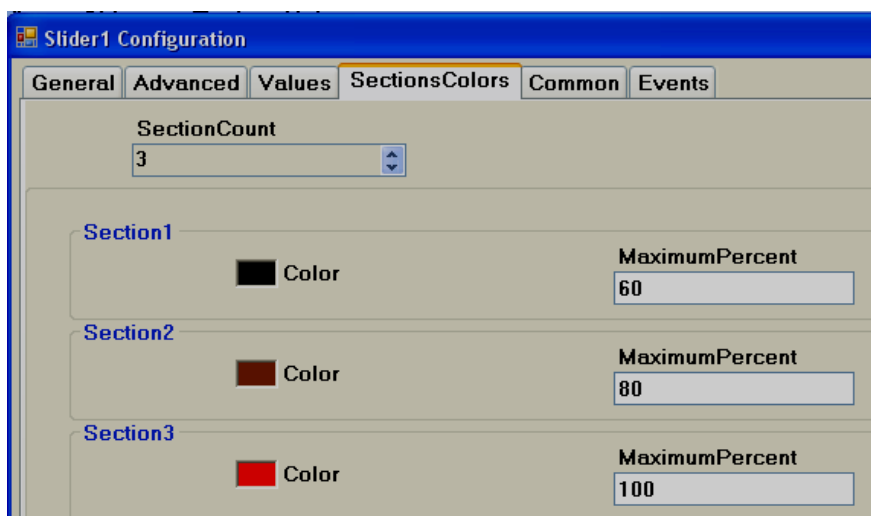

Sections colors: It is configure bands for the sections to show different colors for Labels and Ticks in Slider.

Example: Three bands

Section 1, Max% = 60 means its band is from 0 to 60%. It shows labels and ticks in black color.

Section 2, Max% =80 means its band is from 61 to 80%. It shows labels and ticks in brown color.
 Section 3, Max% =100 means its band is from 81 to 100%. It shows labels and ticks in Red color.

Note: Band setting is in % for the total Scale defined (Minimum to maximum).

6.3.9.2.5 Thermometer

This is normally used to view process temperature by operator during Run time. Generally it is linked with an analog tag (Analog input type tag at PLC, which is received as 4-20 mA signal from field transmitters like Temperature etc.)

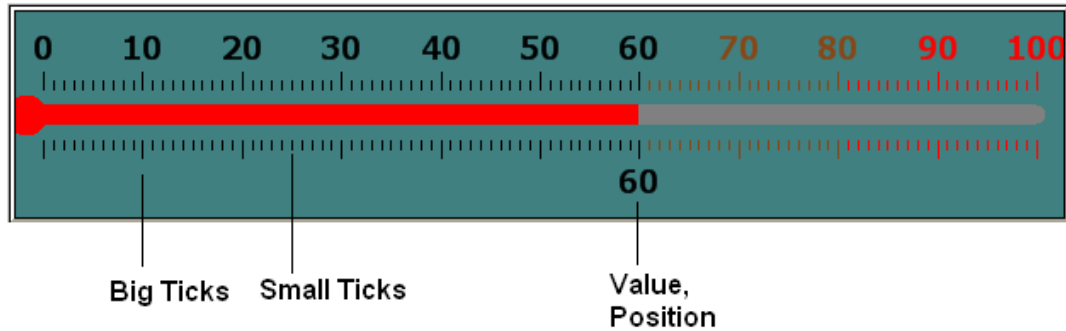

Scale Label Divisions= 10 (0, 10, 20... 100)

Scale Divisions = 10 (No.of Big Ticks)

Scale Sub Divisions = 10 (No.of Small ticks between Big Ticks)

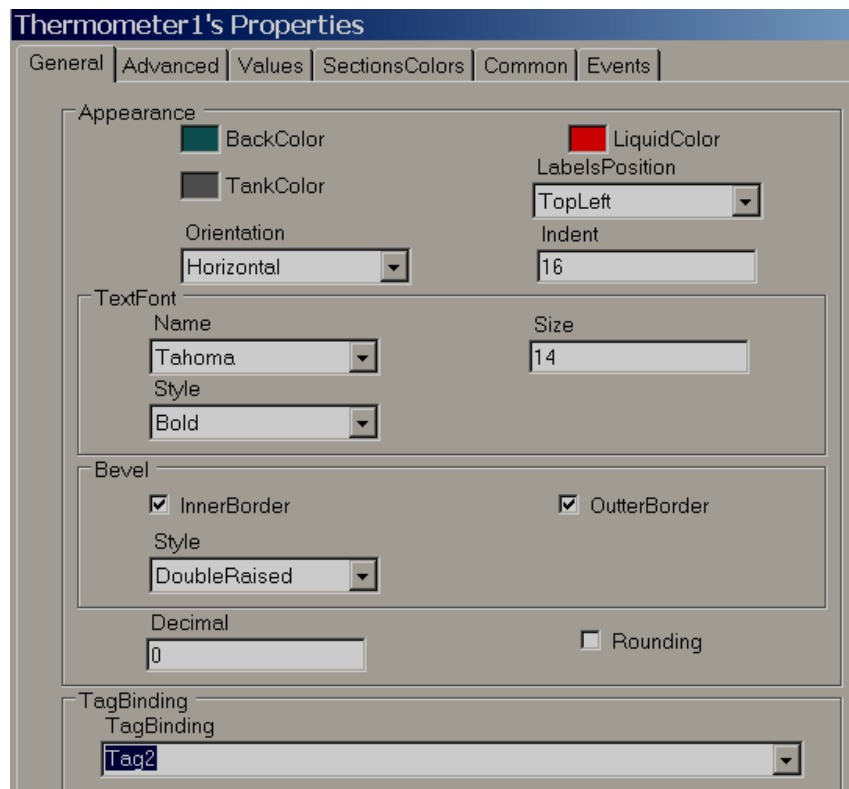

Properties

Back Color: Define back color for the component.

Liquid color: Shows temperature level (mercury) in Thermometer.

Tank Color: Define background color of thermometer without mercury.

LabelsPosition: Define Label position. Available options include Top Left, Bottom Right, Both, Internal and None. The naming convention is based on the selected orientation of the component.

Orientation: Horizontal/Vertical. This is orientation of component. In the figure above, it is in the Horizontal direction.

Indent: It is the gap between border and start of scale.

Text Font: It is to set font for the label including the Name of Font, Size of font and Style of font. Supported styles include Regular, Bold, Italic, Underline & Strikeout.

Bevel: It is to set the border, including the inner border, outer border and style of border.

Inner Border: True/False

Outer Border: True/False

Style: 9 styles are available

None, Flat, Single, Double, Raised, Lowered, Double Raised, Double lowered, Frame Raised, and Frame Lowered.

Tag Binding: Select the Analog Tag of process value.

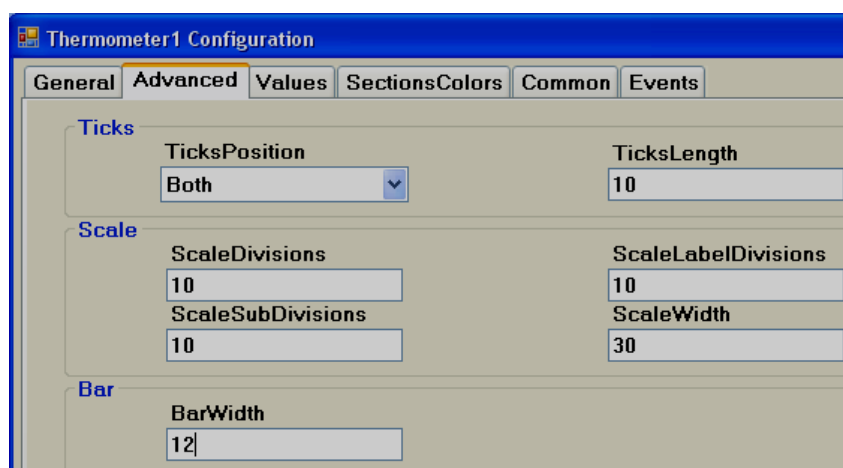

Ticks Position: Define ticks position. Available options include Top Left, Bottom Right, Both, Internal and None.

Ticks Length: Set Tick length in pixels

Scale divisions: Define number of scale divisions (Big Ticks) for the component.

Scale Sub Divisions: Define number of Sub divisions between the above scale divisions (Number of Small ticks between any two Big Ticks).

Scale Label Divisions: Define number of Labels to be displayed for component as per Scale Range of process value. For ex: 0, 10, 20, 30...100.

Scale Width: Define Scale width. If you have ticks on both sides of the component, it defines the width between Upper (Left) & Lower (Right) scale divisions based on orientation of component.

Bar Width: Define width of Bar in pixels.

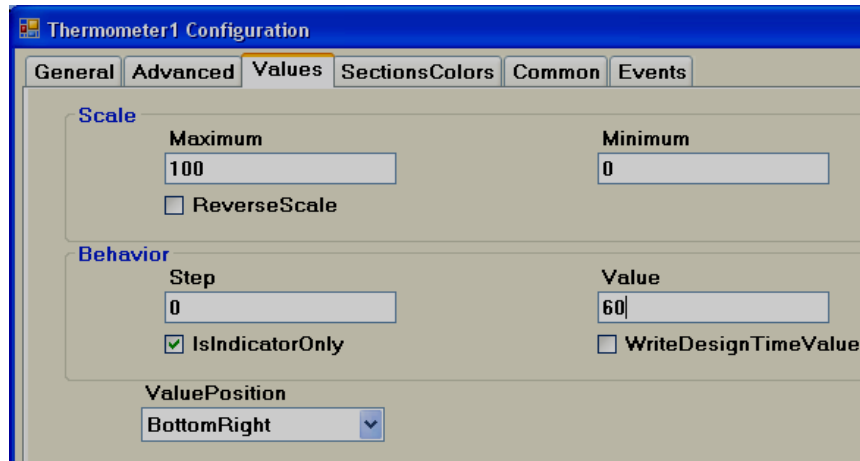

Maximum: This is maximum range of the Set point (Analog Tag, Normally this is an Analog input, 20 mA, 10V DC etc.)

Minimum: This is minimum range of Set Point (Analog Tag, Normally this is an Analog input, 4 mA, 0V DC etc.)

Example: If Temperature transmitter range is 0 to 100°C, set Minimum = 0, Maximum = 100.

Reverse Scale: True/False. Define Scale direction.

Step: It is the minimum value to reflect change of mercury level.

For example: By default, Step = 0 means the Mercury level moves in Real time even with a minor change in process value.

For example: Step = 5 means the Mercury level moves its position in Real time in steps of 5.

Value: It is used to enter a process value during design time and check mercury level position on the PC.

Indicator only: If selected, this component is used for Read only. If it is not selected, then this component can be used for Write/Read purpose.

Write design time value: If selected, it writes design time values instead of default values defined in the tag database.

Value Position: Define position for the value to appear during Run time. Available options include Top left, Bottom Right, Both, Internal and None. The naming convention is based on the orientation of the component.

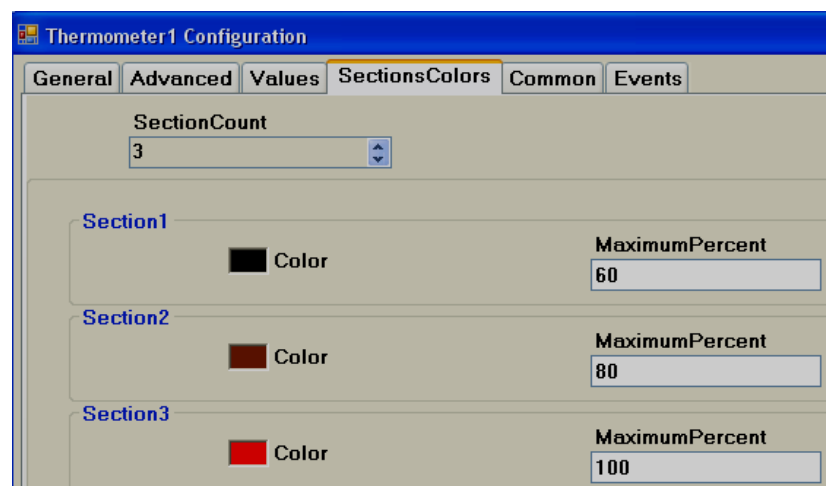

Section Colors: Define bands to display Ticks and Label color accordingly based on the value of the tag during Run time.

6.3.9.2.6 Bar Box

Bar Box is a Graphical User Interface widget that displays a bar graph for an Analog Tag during Run Time. Every Bar box should be linked with an **Analog** Tag.

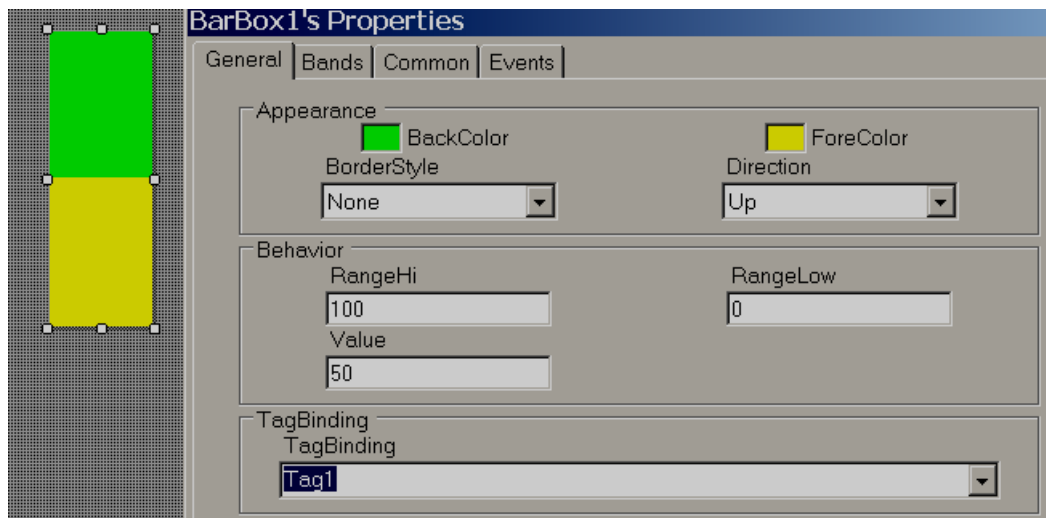

Properties

Border Style: Define border style. Options include fixed single, fixed 3D and none.

Direction: Define direction of Bar graph. Up/Down/Left/Right

Range high: Display scale high.

Range Low: Display scale low.

Value: Default value. It is to check how fore color, back color displays in PC during design time.

Tag Binding: Select the Analog Tag of process value.

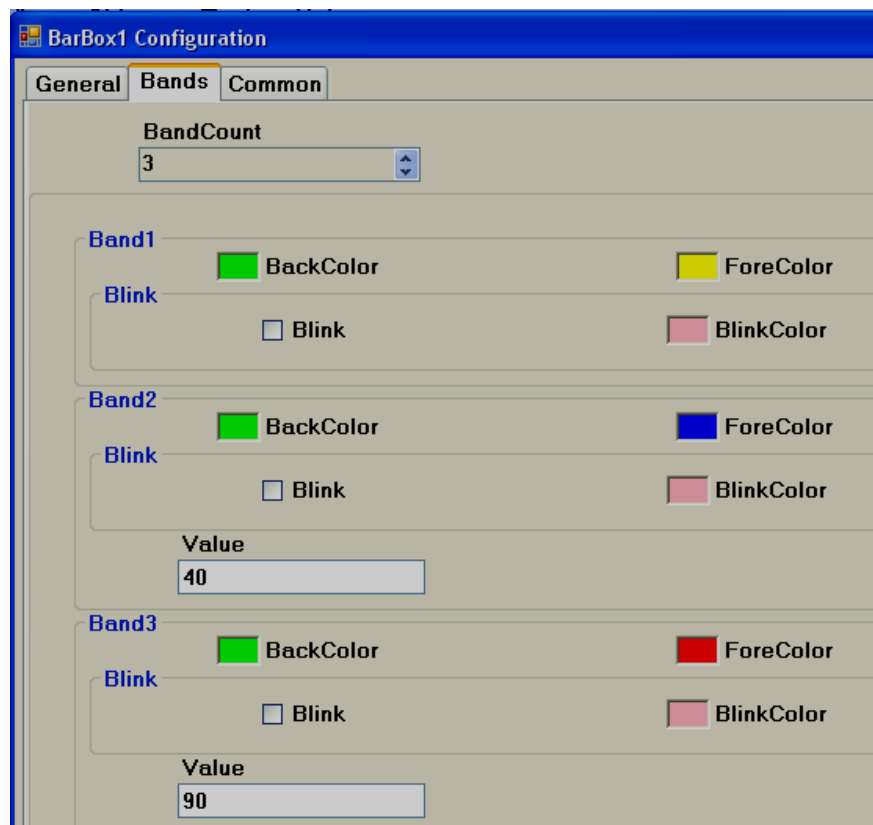

Bands

It is to define various bands for the process value to appear and display animation in Run time.

Band count: Use up/down buttons to increase/decrease number of bands. Maximum 32 bands are supported. In each band, it is possible to configure back color, fore color and blink properties.

Back color: Define back color.

Fore Color: Define fore color.

Blink: Select "True" if blink is required and "False" if blink is not required.

Blink color: If "True" is selected for blink, then this property is visible and you can select required blink color.

Value: It is the band range. For the first band, it is always the Range Low value defined for the bar box. Band 1 high range is the value defined at Band2. Band2 high range value is the value defined at Band3 and so on.

6.3.9.2.7 Scale

Scale is a Graphical User Interface widget used along with bar box if required.

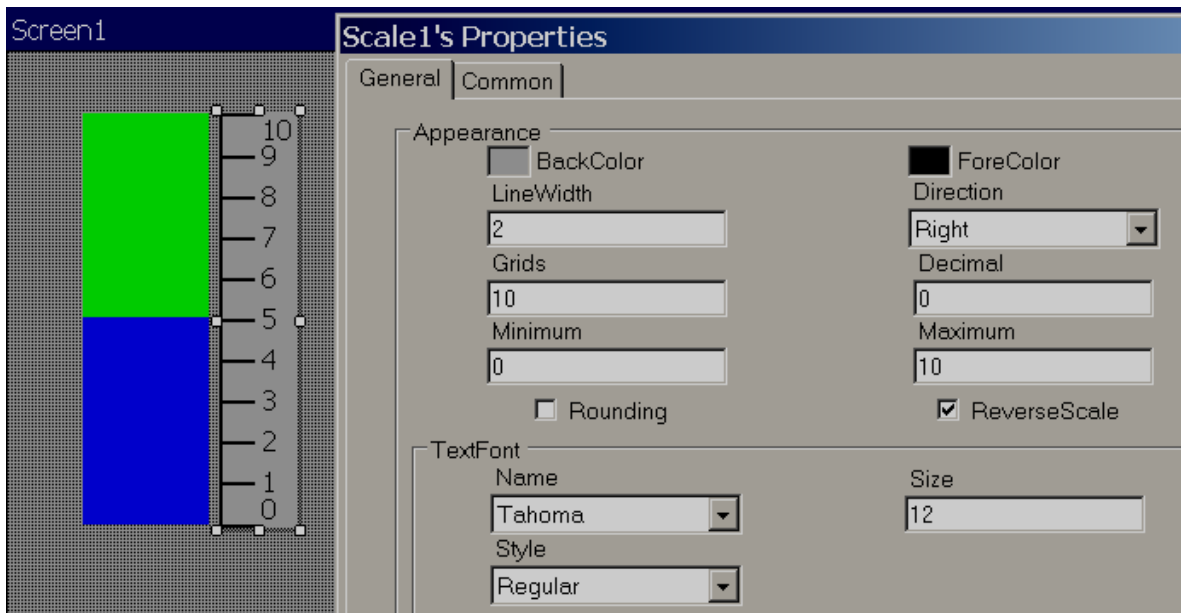

Properties

Back color: Define back color

Fore Color: Define fore color

Line width: Define width of line

Grids: Define number of grids

Direction: Define direction of Scale. Up/Down/Left/Right

6.3.9.2.8 Picture box

Picture box permits the user to link different picture files into a Picture box component during design time and then later view them during Run time based on the value of the Tag. Supported formats include Bitmap file (*.bmp), Windows Metafile (*.wmf), JPEG File (*.jpg), Graphics Interchange format (*.gif), Portable Network Graphic (*.png).

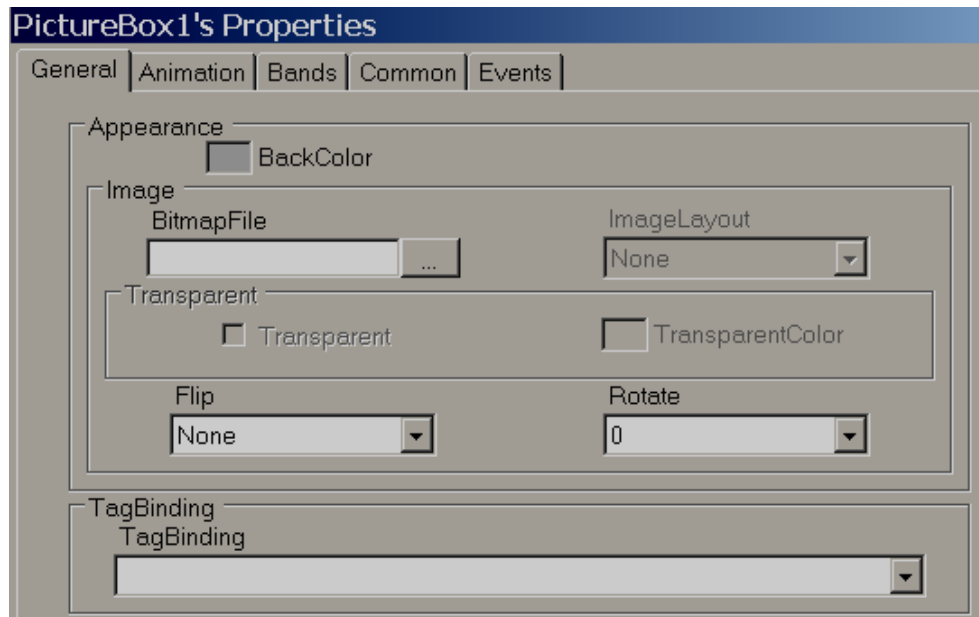

Properties

Bitmap file: Select the image to be shown in the object

Flip: It is to flip picture file during design time. Available options are Horizontal, Vertical, Both and None.

Rotate: It is to select direction for the picture file during design time to adjust direction. Available directions include 0°, 90°, 180° and 270°

Tag Binding: Select the Analog tag to be linked with Picture box.

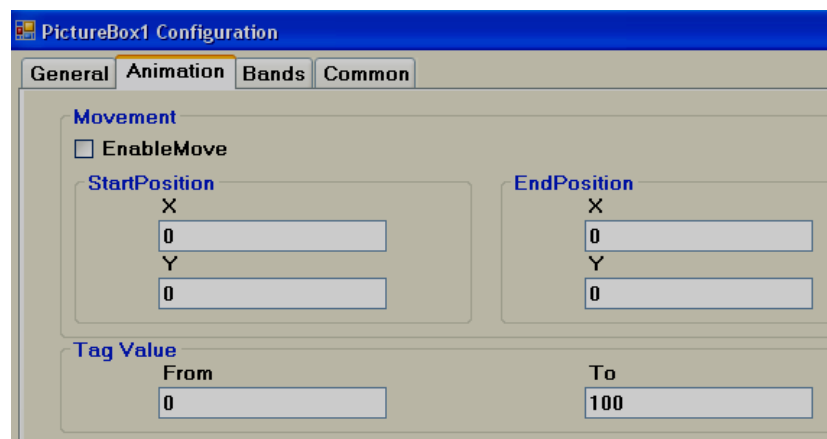

Movement: Select "Enable Move" if it is required to move picture during Run time from Location 1 to Location 2 based on a tag Value. Start and End coordinates for X and Y needs to be configured during Design time, and the Picture moves in Run time based on a Tag value.

Tag Value: Define Tag value

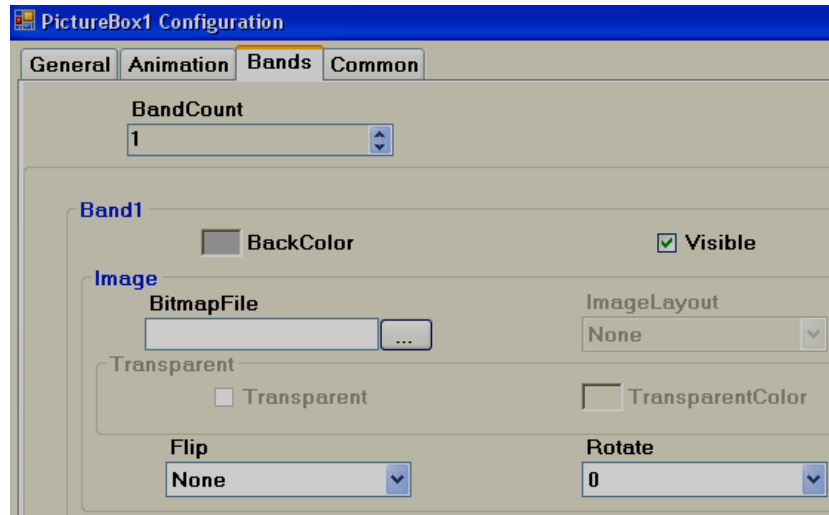

- Band Count:** Define number of bands required.
 - Back Color:** Define back color for the selected picture file in specific band.
 - Visible:** Define visibility for the picture in specific band.
 - Bitmap file:** Select picture file for specific band.
 - Image Layout:** Position of image within Picture container. Available options include None/Center/Stretch. When stretch is selected, it attempts to fit the picture file to the size of container.
 - Transparent:** Select if no back color is required for picture file.
 - Flip:** It is to flip picture file during design time. Available options are Horizontal, Vertical, Both and None.
 - Rotate:** It is to select the direction for the picture file during design time to adjust direction. Available directions include 0°, 90°, 180° and 270°
- Example: You may take a photo of a section of the factory floor like a tank, then use this on the Recorder screen instead of a default symbol.



A bitmap file by the name sunset.jpg is linked with PictureBox1 in screen1. If you wish to have the same sunset.jpg in screen no 2, do not create picture box and link with sunset.jpg again. Since a resource with name sunset already available, if you try to use the same image in other place, it may not allow you to do so, and may give you an error message. If you really need the same image again, copy picture box1 at screen1 and paste it in screen no 2.

6.3.9.3 Graphics

Graphics are used to place a symbol in a screen like a Tank, Motor etc. Basic symbols are available in Recorder Editing Software and it includes the following symbol categories.

Symbol categories

No	Category	Symbols	Colors	Qty
1	Arrows	7	6	42
2	Blowers	5	6	30
3	Boilers	4	6	24
4	Conveyors	6	6	36
5	Instruments- True Color	7	C	7

No	Category	Symbols	Colors	Qty
6	Lamps	4	6	24
7	Material handling	8	C	8
8	Motors	4	6	24
9	Nature-True Color	6	C	6
10	Office-True Color	7	C	7
11	Pipes	10	6	60
12	Power-True Color	7	C	7
13	Pumps	5	6	30
14	Push buttons	8	6	48
15	Tanks	5	6	30
16	Valves	8	6	48
17	Vehicles-True Color	6	C	6

C = True Color

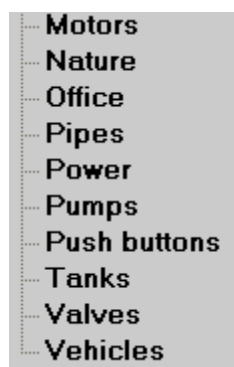
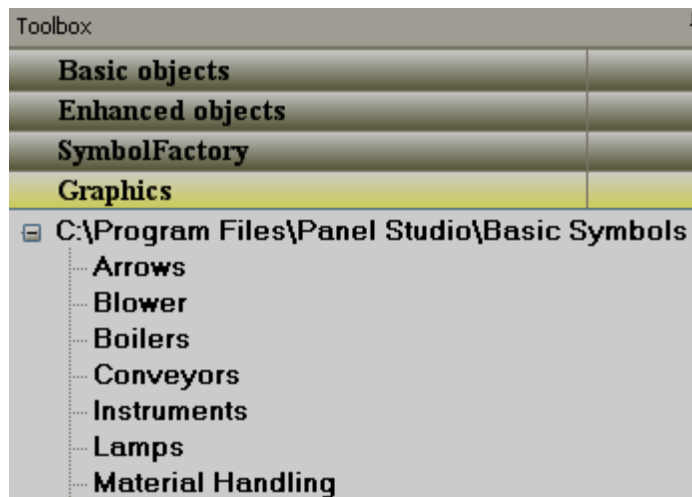

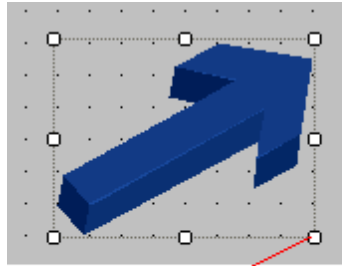

Use these cursor points to change the size

Some symbols are available with 6 different colors. They are Red, Green, Yellow, Blue, Brown and Grey.

All the symbols are vector graphics. They occupy less memory and have high quality.

It is possible to set the transparent property for symbols during design time from the property grid. "Transparent" means the screen color itself will appear as back ground color, making the object appear to be see through. Also, it is possible to change the symbol background color during design time and Run time.

How to set the "transparent" property to a symbol from the property grid

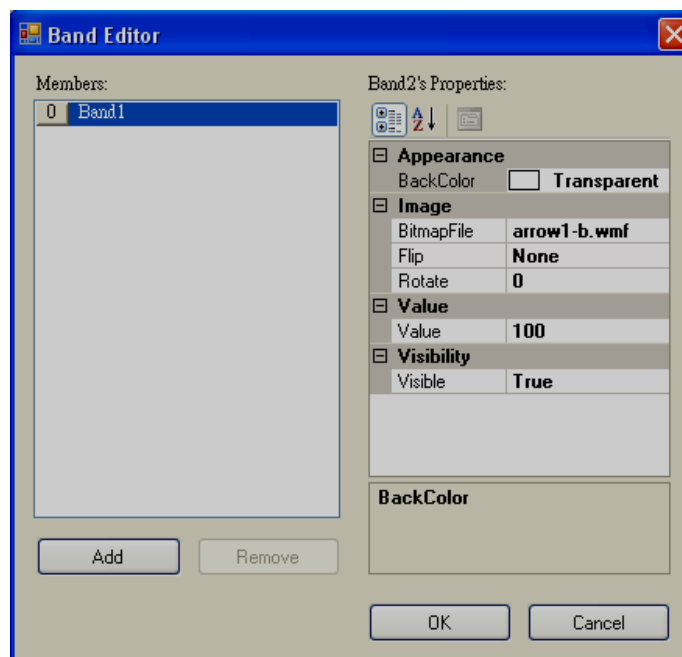
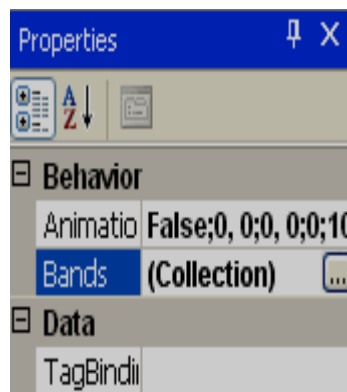

Click "Bands", then set "BackColor" to "Transparent"

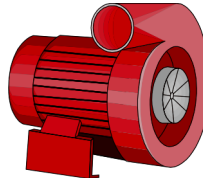

Fig: Back color=Transparent

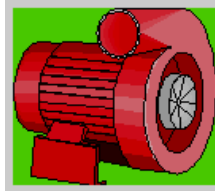

Fig: Back Color=Green

Since all symbols are vector symbols, if a symbol is enlarged, it does not lose quality.

When Recorder Editing Software is installed, all basic symbols will be installed in the default folder C:\Program Files\Recorder Editing Software\Recorder Editing Software\Basic Symbols

In addition, if the application developer has any additional symbols, they can be placed in the same folder as the basic symbols for use in the project.

Example: Create a folder named "Custom", and place it in C:\Program Files\Recorder Editing Software\Recorder Editing Software\Basic Symbols

It is possible to set a path for graphic symbols in the Recorder software. On the Menu bar, click the "File" dropdown menu, select "Environment", then select "Graphics path". All these will appear in a tree type structure within Recorder editor avoiding the need to import these symbols using a "Picture Box".

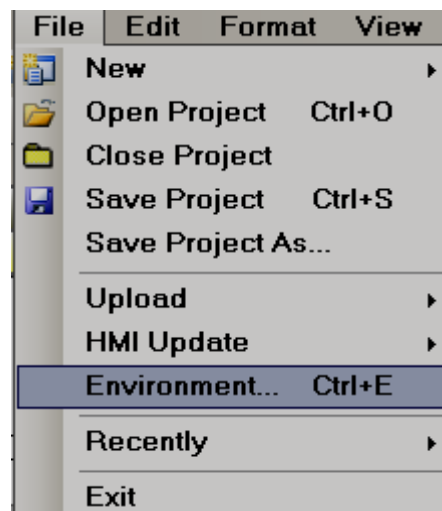

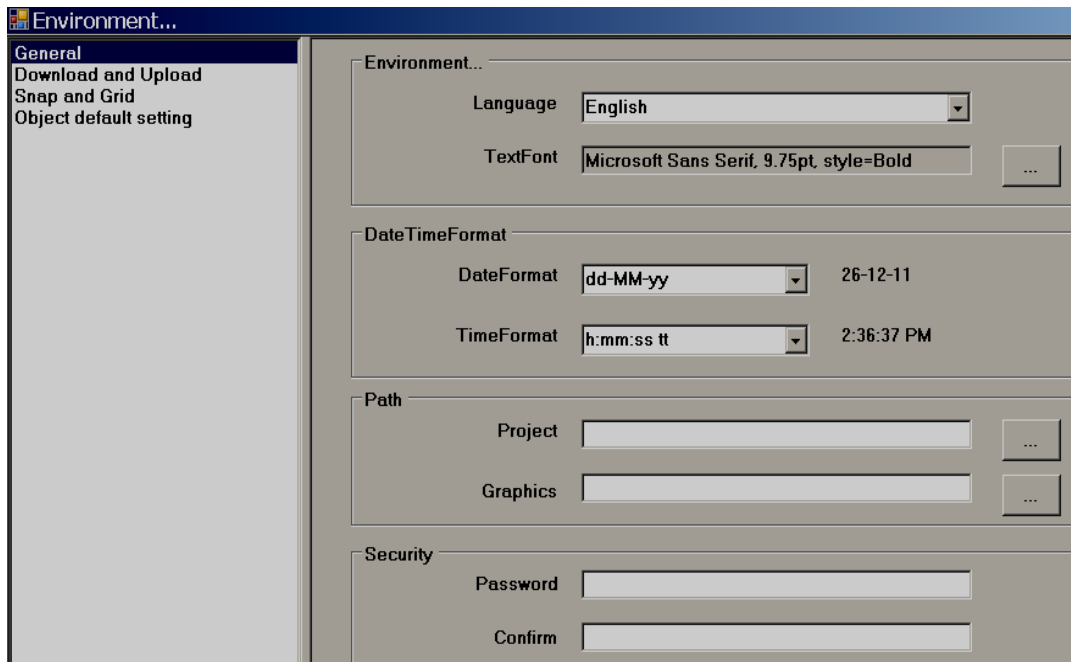

Once a symbol is selected in the Recorder from Graphics, it is possible to change, Flip or rotate basic symbols in 0°, 90°, 180° and 270°



Properties

Tag Binding: Select an Analog Tag if animation is required for the symbol in Run time.

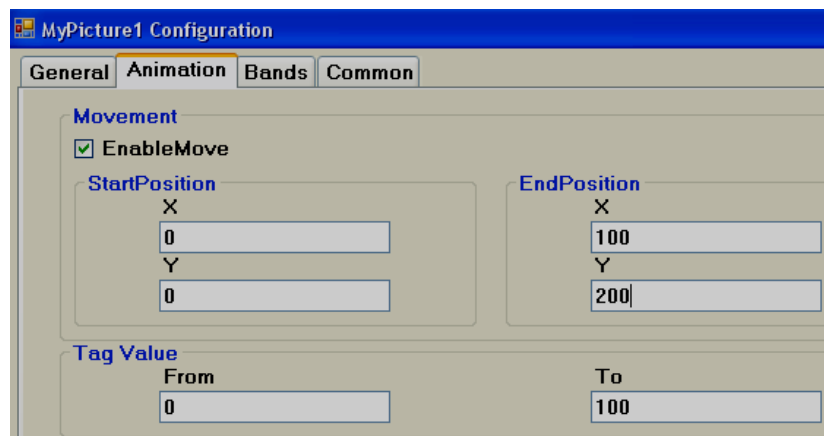

Movement: Select the Enable/Move checkbox, then, enter the X and Y start and end positions (this is in pixels).

Tag Value: Linked with the Start and End Positions.

Ex: Recorder 7" (High Performance), Screen Resolution = 800 X 480, Horizontal installation, Width = 800, Height = 480. Move symbol from Left to Right of screen during Run time when tag value changes from 0 to 100

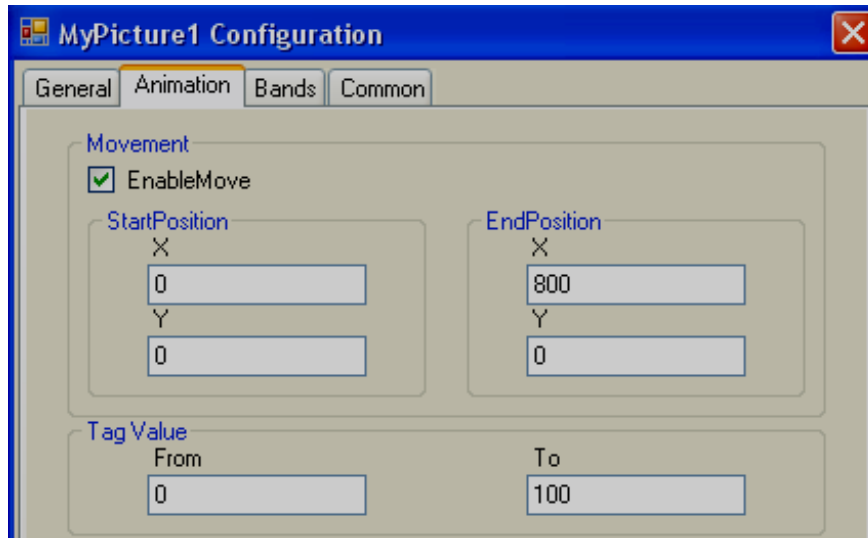

To move the symbol from Left to Right, set start and end Positions for X coordinate in pixels, there is no need to set Y coordinates.

Tag value = 0 corresponds to Start Position (X)

Tag value = 1000 corresponds to End Position (X)

Ex: Recorder 7" (High Performance), Screen Resolution = 800 X 480, Horizontal installation, Width = 800, Height = 480. Move symbol from Top to Bottom in screen at Run time when tag value changes from 0 to 100

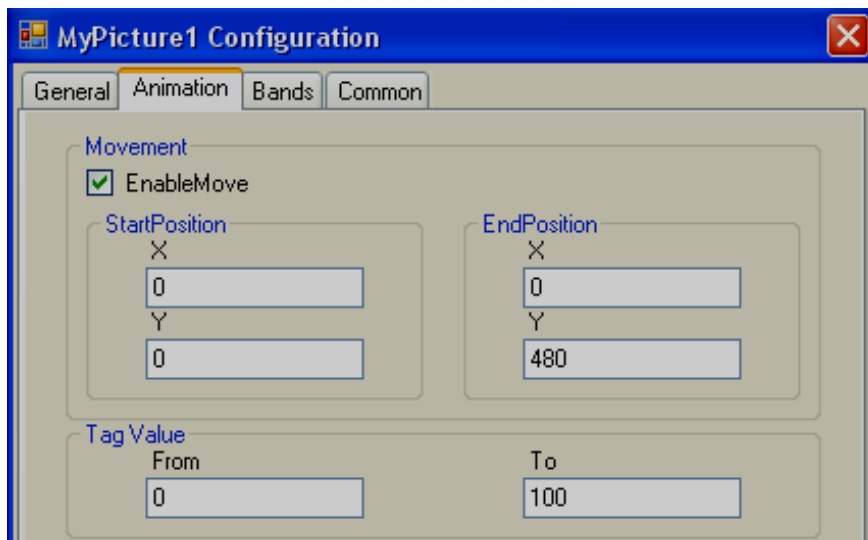

Ex: Recorder 7" (High Performance), Screen Resolution = 800 X 480, Horizontal installation, Width = 800, Height = 480. Move symbol from Left Top to Right Bottom on screen at an angle during Run time when the tag value changes from 0 to 100

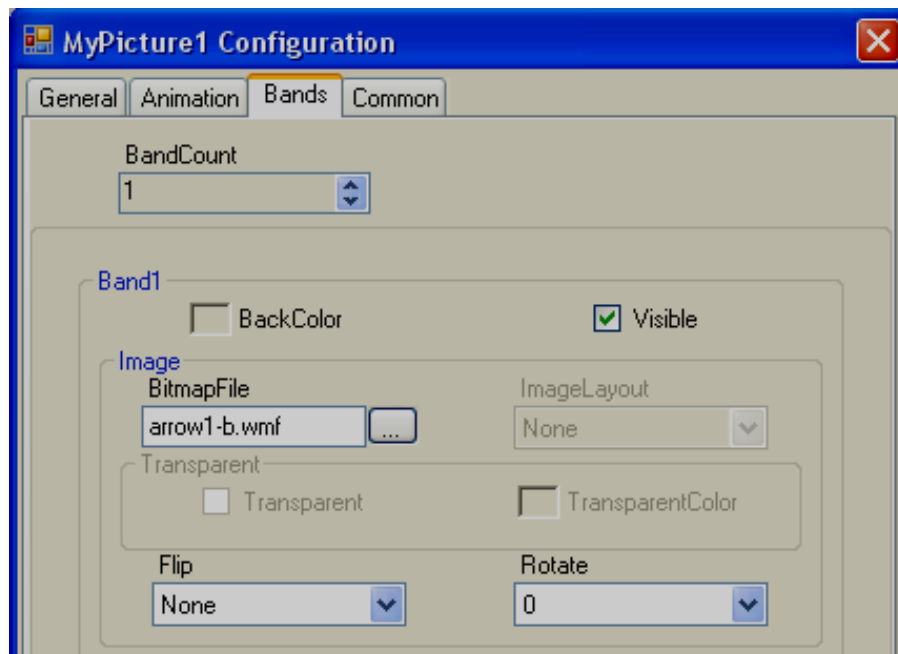
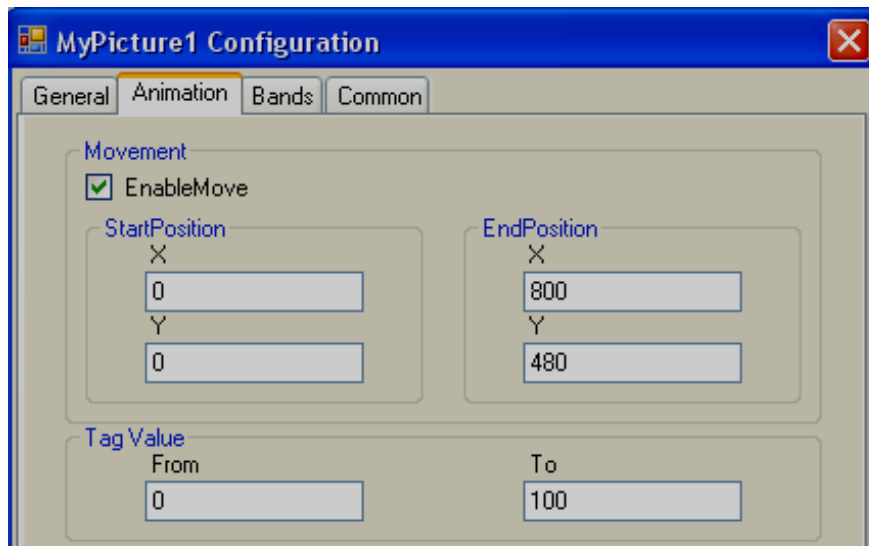

Band Count: Used to define bands for run time animation of symbol. Max. 32 bands are supported.

Back Color: Define Back Color of the symbol that should appear in a specific band during Run time.

Visible: Define visibility control for the symbol in a specific band during Run time.

Image: Select different image file to display in a specific band during Run time.

Flip: Define the flip position for the symbol in a specific band during Run time. Available options include None, Horizontal, Vertical and Both.

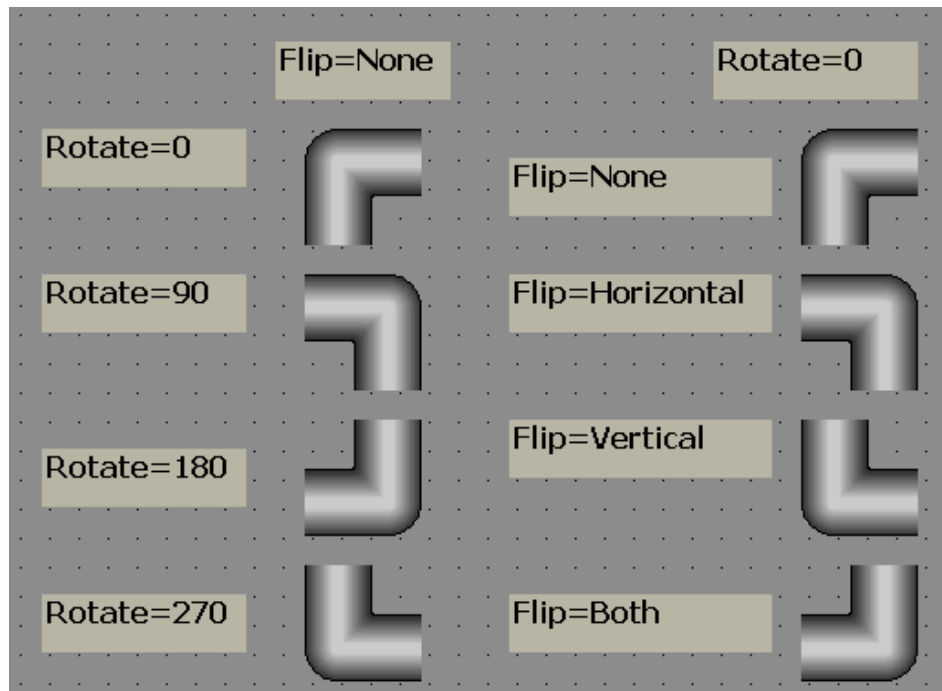

Rotate: Rotate symbol to any predefined direction in a specific band during Run time. Available options include 0°, 90°, 180° and 270°

Example: There is Liquid level Tank. When the Tag value = 0, an arrow should appear pointing in the Down direction indicating that a discharge of the tank is in progress. When the Tag value = 1, the arrow should appear in the Up direction indicating filling of tank is in progress.

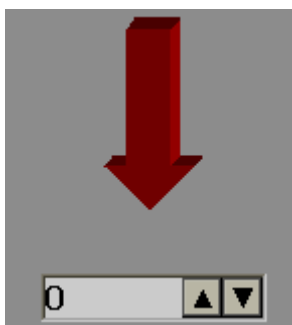
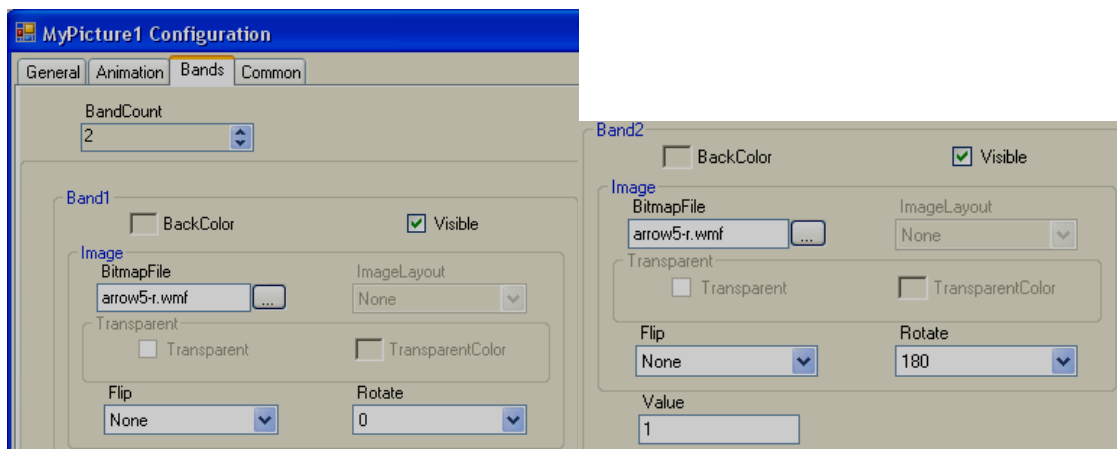

6.3.9.4 Symbol Factory

Symbol Factory® contains more than 4000 symbols in 64 categories.

No.	Category	Symbols	No.	Category	Symbols
1	3-D Pushbuttons Etc.	73	35	Machining	90
2	Air Conditioning	140	36	Maps and Flags	23
3	Architectural	49	37	Material Handling	118
4	Arrows	63	38	Mining	63
5	ASHRAE Controls & Equipment	100	39	Misc. Pipes	39
6	ASHRAE Ducts	86	40	Misc. Symbols 1	57
7	ASHRAE Piping	49	41	Misc. Symbols 2	79
8	Basic Shapes	86	42	Mixers	24
9	Blowers Etc.	34	43	Motors	38
10	Boilers	36	44	Nature	71
11	Buildings	42	45	Operator Interface	28
12	Chemical	50	46	Panels	14
13	Computer Hardware	38	47	Pipes	82
14	Computer Keys	68	48	Plant Facilities	52
15	Containers	56	49	Power	61
16	Controllers	35	50	Process Cooling	20
17	Conveyors, Belt	40	51	Process Heating	61
18	Conveyors, Misc.	26	52	Pulp & Paper	35
19	Conveyors, Simple	56	53	Pumps	99
20	Ducts	51	54	Safety	27
21	Electrical	83	55	Scales	36
22	Finishing	45	56	Segmented Pipes	41
23	Flexible Tubing	24	57	Sensors	55
24	Flow Meters	35	58	Tank Cutaways	23
25	Food	72	59	Tanks	145
26	General Mfg.	68	60	Textures	181
27	Heating	108	61	Valves	73
28	HVAC	74	62	Vehicles	41
29	Icons and Bitmaps	159	63	Water & Wastewater	112
30	Industrial Misc.	19	64	Wire & Cable	21
31	International Symbols	42		Total	4045
32	ISA Symbols	183			
33	ISA Symbols (3-D)	123			
34	Laboratory	23			



With Recorder Editing Software, only the first symbol from the symbol factory can be selected. If you need all symbols, order our Recorder Editing Software Plus, and we will supply a USB hardware lock to access more than 4000 symbol factory graphics.



It is possible to link an Analog Tag with a Symbol factory graphic and change its colors during Run time. Up to 50 bands are supported.

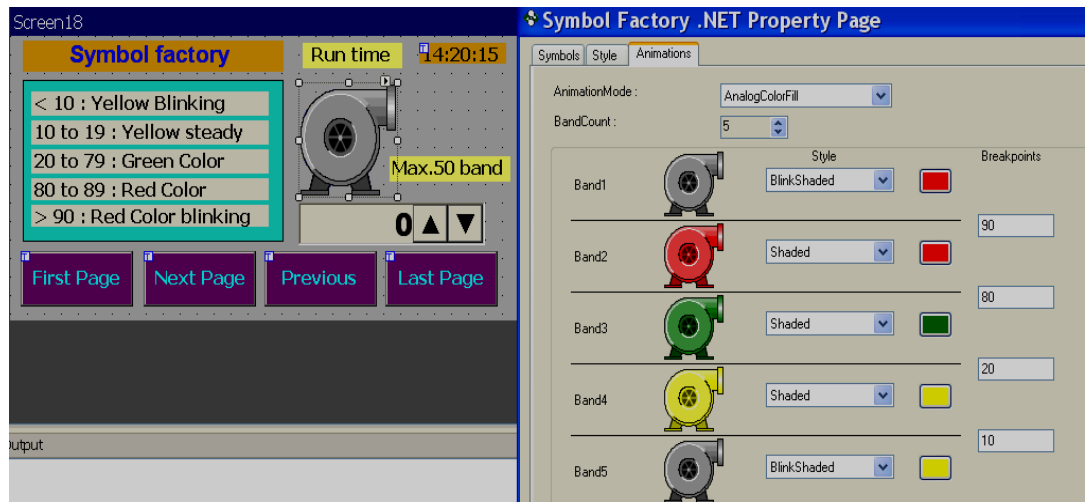
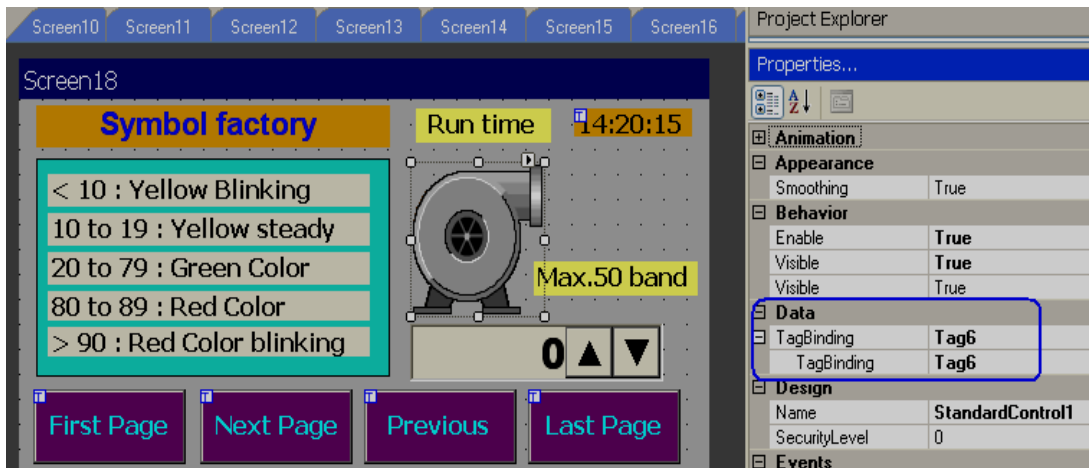

Design Time

During design time, the applications engineer is allowed to change the colors of these symbols.

Example: Change tank color from standard grey scale to Green color.

Task: Place symbol on a screen

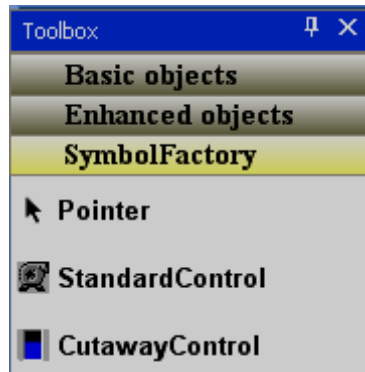

In Tool box, click “Symbol Factory”, then drag and drop a standard control to the screen.

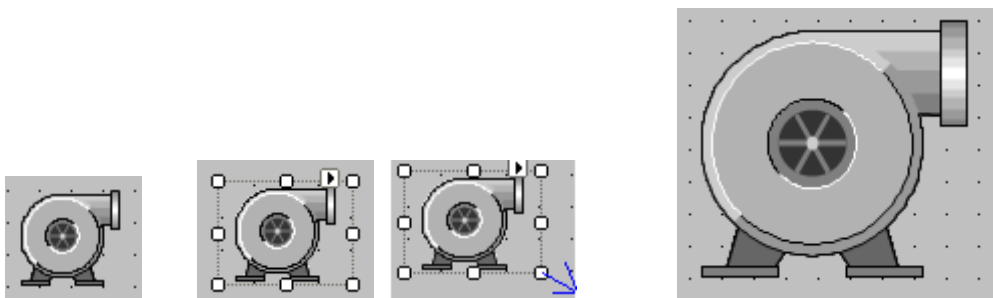

Fig 1

Fig2

Fig3

Fig4

Task: Increase size of symbol

Select the symbol on the screen. It will be as shown as in fig2 above.

Then, move mouse to a square pointer till an arrow appears. Left-click and hold the mouse. Drag the mouse to increase size of symbol as per your requirement and then it will be as shown as in Fig4 above. Alternatively, in the property grid, enter the size in pixels as shown below.

Size	120, 100
Height	100
Width	120

Task: Changing symbol to another category

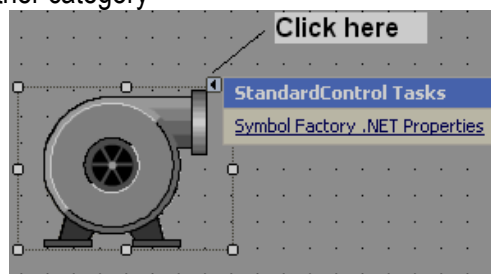

Drag and the drop symbol factory component onto a screen.

Click , then click on Symbol Factory.NET Properties.

Alternatively, select the symbol factory component using single click (left) with the mouse. Keep the mouse cursor on the symbol, then, double click (left) the mouse to open symbol properties. The following screen will pop up.

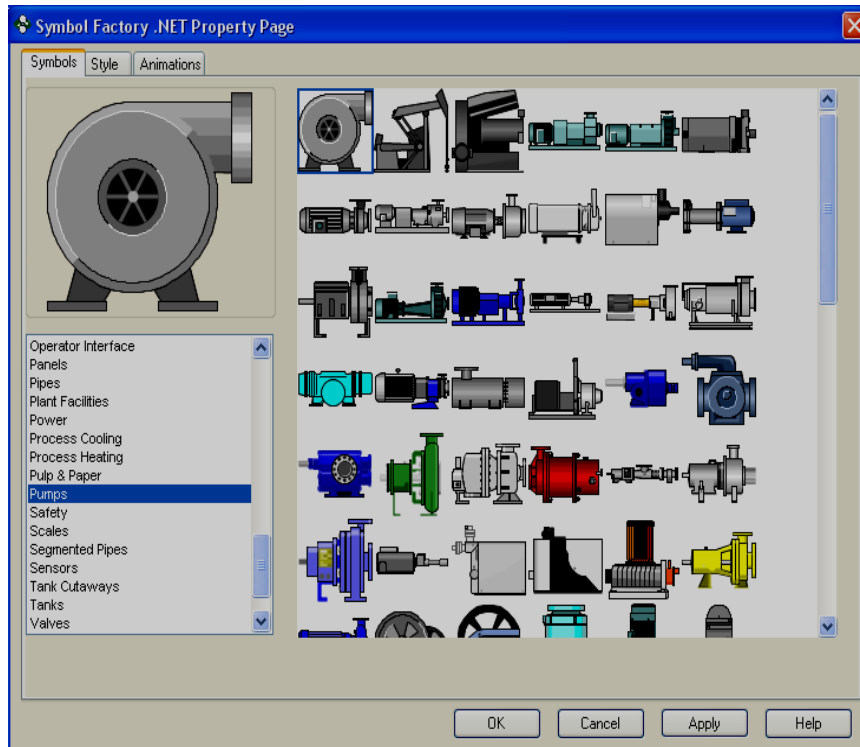

Select the required category, select the symbol, then click on button “OK”, then new symbol will be placed in screen.



Click on Help in the above screen to open a Chm type help file (English) for the symbol factory.

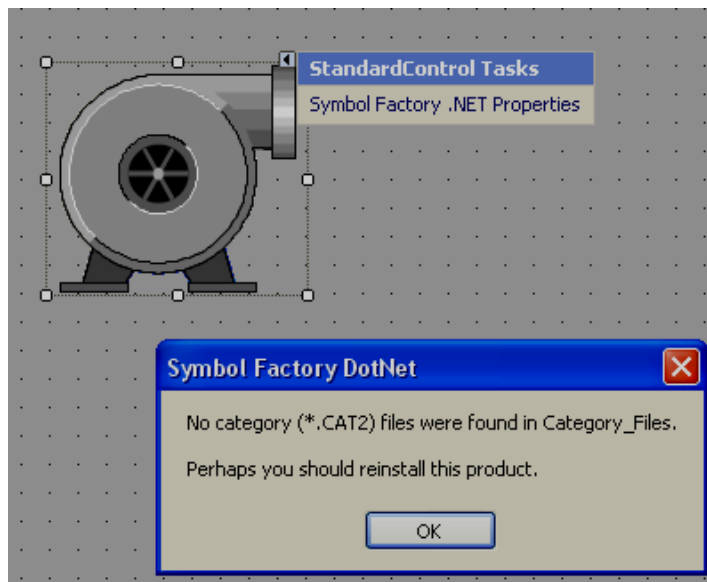

If the above error message appears, it is required to reinstall symbol factory.

Style

Used to define the style of symbol in design time.

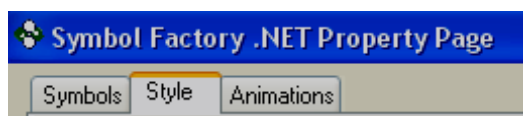

Click on “Style”. The following screen will appear.

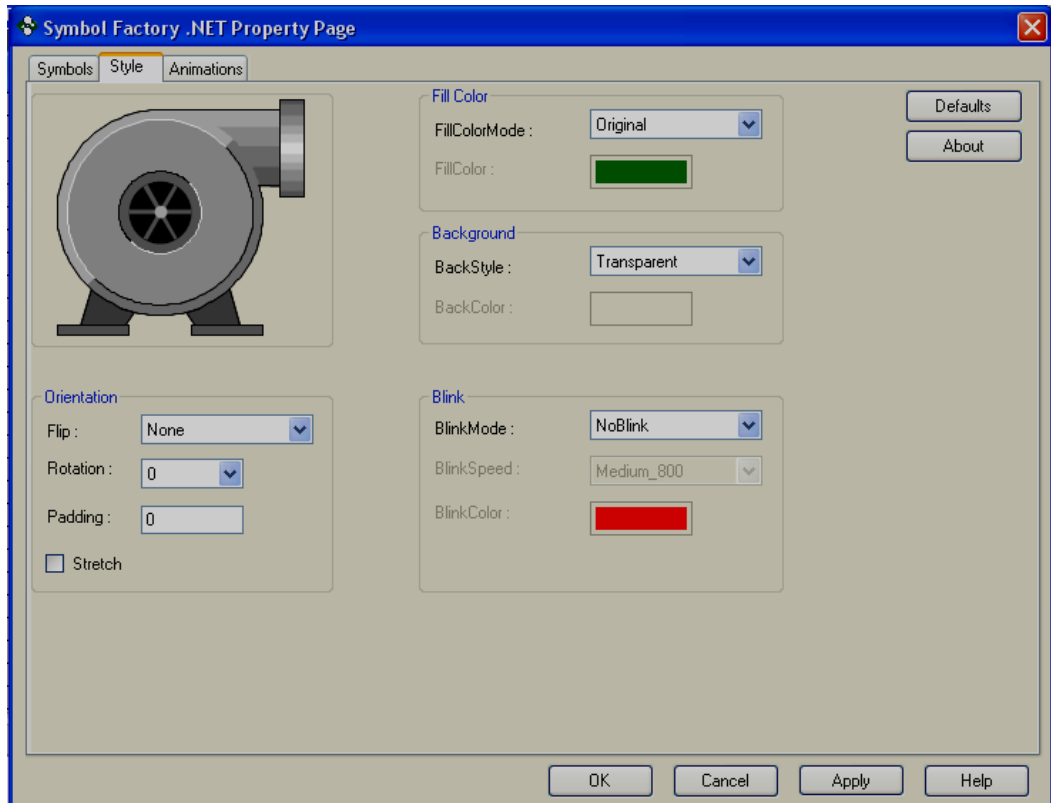

Orientation:

Flip: It is possible to flip the symbol during Design time. Available options include Horizontal, Vertical, Both and None.

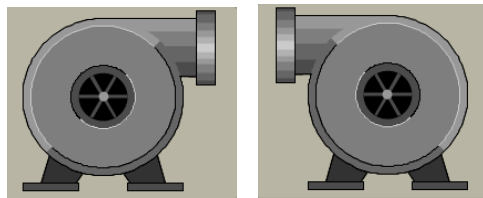

Flip = None

Flip = Horizontal

Rotation: It is possible to rotate symbol during design time. Available options include 0°, 90°, 180° and 270°

Padding: Normally it is 0. It is used to decrease size of symbol within selected boundaries.

Stretch: It is used to stretch symbol within selected boundaries.

Fill Color:

Fill color mode: Available options include Original, Shaded, Solid and Hollow.

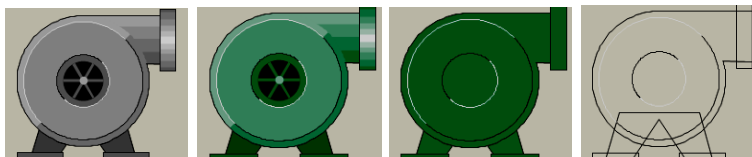

Fill Color Mode: Original

Shaded Solid

Hollow

Fill Color: N.A

Green

Green

N.A

Fill color: Define color to be filled in Shaded and Solid fill color mode.

Background:

Back Style: Available options include Transparent & Opaque. Transparent means screen background color will appear for symbol. Opaque means, it is possible to set different background colors for a specific selected symbol.

Back color: Define background color when the back style = Opaque.

Blink:

Blink mode: Available options include No Blink, Blink Invisible, Blink shaded and Blink Solid.

NoBlink: Indicates “Blink” is not required for symbol during design time or Run time. Blink Speed and Blink color = Not available when this is selected.

BlinkInvisible: Symbol will appear and disappear cyclically during both design time and Run time per the set Blink speed. Blink color: Not Available for selection.

BlinkShaded: Symbol will flash 2 colors, one color at a time on the same symbol per the set blink speed during both design time and Run time.

Example

Fill Color mode = Shaded, Color = Green

Blink shaded setting: Blink mode = Blink shaded, Blink speed = Medium_800, Blink color = Blue

The green color shaded symbol appears first, then the symbol turns into a blue shade after elapsing the preset time in the blink speed setting.

Blink speed: Define blink speed. Available options include Fast_400, Medium_800, and Slow_1200. Its period is in **ms**.

Blink color: Define background color



Normally, blink is not used during design time. Default settings are as follows.

1. Fill Color Mode = Original. If a different color is required for the symbol, select Fill color mode = Shaded, then define the Fill color.
2. By default, Back Style = Transparent in Background
3. By Default, Blink mode = NoBlink

Animation

It is to define animation for the symbol to appear at Run time in Recorder.

Animation mode: Define animation mode. Available options include Analog Color Fill, Discrete color fill, Analog integer color fill.

AnalogColorFill: Select this option if you wish to link an analog tag. Then define the band for the colors. For ex: 0 to 10, Color = Yellow, 10-90, Color = Green, 90-100, Color = Red etc.(See next section “How break points work” for more details)

DiscreteColorFill: Select this option if you wish to pass discrete values like 1, 2, 3 ... during Run time to the Tag linked with symbol for the display of different colors. (See next section “How break points work” for more details)

AnalogIntegerColorFill: This is the same as Analog color fill, but only integer values are passed to the Tag linked with the symbol. (See next section “How break points work for more details)

Band count: Defines the number of bands required for the selected Animation mode

Styles: Define style of symbols. Available options include Original, Shaded, Solid, Blink Invisible, Blink shaded and Blink solid. All definitions are the same as explained earlier.

6.3.9.4.1 How break points work

The idea behind Break points is that certain animation will occur when a property of the component changes. If this change falls within the defined parameters (see below), an animation will be triggered.

Please note: The screen shots in the examples below are based upon the Symbol Factory .NET Standard Control, but the same principle applies to the Cutaway control. Two types of animation can be defined based upon the setting of Animation Mode: Analog Break Points and Discrete Break points

Analog Break points (Animation Mode = Analog integer color fill or Analog color fill) Analog break points are defined as a value on which an animation will trigger when a property of the component reaches that level. Depending upon your component, different properties will need to be changed depending upon the setting of Animation Mode. These properties are:

Component	Animation Mode Setting	Property that Changes to trigger an Animation
Standard	AnalogColorFill	AnalogValue1
Standard	AnalogIntegerColorFill	AnalogIntValue1
Cutaway	AnalogColorFill	Level
Cutaway	AnalogIntegerColorFill	LevelInt

Number and Ordering of Break points

The number of break points available to you is the number of bands defined minus 1. As a break point is defined as the point to which an animation changes, make sure you arrange the break points from high to low. For example, suppose you had this screen:



When the value of your property changes, this is what will happen to the control:

Value of Property	Band that is Active	Appearance of Component
Less than 10	Band5	Blink Shaded Red
10 to < 20	Band4	Display Shaded Yellow
20 to < 80	Band3	Original
80 to < 90	Band2	Display Shaded Yellow
Greater than 90	Band1	Blink Shaded Red

If you do not order your break points in a descending order, your results will be unpredictable. Discrete break points (Animation mode = Discrete color fill)

Discrete Break points aren't really break points, instead, they enable animation if the "DiscreteValue" of an element in the BandsCollection is set to true. However, since multiple DiscreteValue properties can be set at the same time, how does the component determine the animation to display? What it does is give priority to the animations based upon their order in the BandsCollection. If the first band in the collection (by default, Band1) has its DiscreteValue set to True, then that animation will be shown no matter which band also has its DiscreteValue set to true. As another example, if Band2 and Band5 each have their DiscreteValue set, the animation that is used will be the one defined in Band2. Therefore, given the following definition of five bands:



Here is what the animations will be shown based upon different values of Discrete Value

Discrete Value for Band1	Discrete Value for Band2	Discrete Value for Band3	Discrete Value for Band4	Discrete Value for Band5	Appearance of Component
True	False	False	False	False	Blink Shaded Red (Band 1)
False	True	False	False	False	Shaded Yellow (Band 2)
False	False	True	False	False	Original (Band 3)

Discrete Value for Band1	Discrete Value for Band2	Discrete Value for Band3	Discrete Value for Band4	Discrete Value for Band5	Appearance of Component
False	False	False	True	False	Shaded Orange (Band 4)
False	False	False	False	True	Blink Shaded Black (Band 5)
True	True	True	True	True	Blink Shaded Red (Band 1)
False	True	True	True	True	Shaded Yellow (Band 2)
True	False	False	False	True	Blink Shaded Red (Band 1)
False	False	False	False	False	Original (No bands active)

6.3.9.5 Project Tools

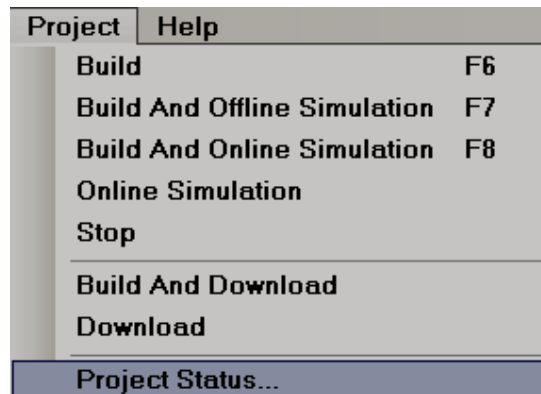

6.3.9.5.1 Build

Once the project is compiled successfully, it creates a build. This build then needs to be transferred to the Recorder. If there are any errors during the preparation of the build, it will be shown in the output window just below the screen working area. If the Output screen is not visible below the screen working area, select it via Menu, "View", and then click "Output" or apply "Reset window layout" from the Menu - "View"

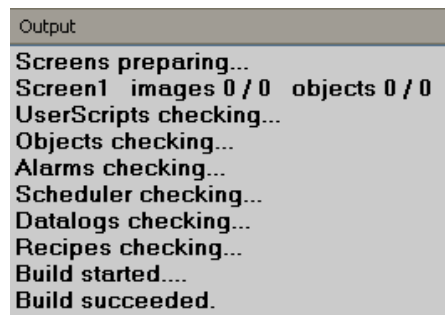

After creating a build, if any errors are shown at Output window, do not attempt to download the application from PC to Recorder, or PC to USB flash disk first clear the errors and make sure that compilation errors are not present before transferring the application to the Recorder.

6.3.9.5.2 Build & Offline Simulation

First, it creates a build, then runs an Offline simulation.

It is used to test the application on the PC before downloading the application to the Recorder, without connecting a PLC to either PC or Recorder. It is possible to enter some values for the tags via a table to check how the application would appear during run time.

Tag	CurrentVal	SetVal
Tag1	12	
Tag2	0	
Tag3	0	
Tag4	0.0788529868553987	
Tag5	58.4416722356357	
Tag6	0	
Tag7	0.39426493427699	
Tag8	0.39426493427699	
Tag9	0	
Tag10	0	

Enter a value under the “SetVal” column, then press the enter key on your keyboard. It will accept, then show at “CurrentVal”. You will now be able to see these values in objects linked with the specific tag.



It is better to run offline simulation frequently say once in couple of hours or after completing specific screen editing by application engineer to verify how it will works on a Recorder so that if there are any compilation errors, it is easier to locate and rectify them.

6.3.9.5.3 Stop

It is used to stop a simulation on the PC. When Offline simulation is running, click the  Icon to stop the current running simulation. See the picture below. It is located beneath the “help” dropdown menu.

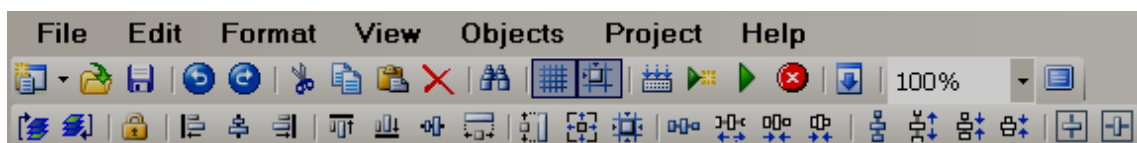

If Offline simulation or online simulation is already running on the PC, and the user attempts to run it again, the build will fail. It prompts an error message similar to the following



Screen1

Build Started....

Could not write to Output file “C:\Program Files\Project\Recorder\Panel.exe”

“The process cannot access the file because it is being used by another process”

Build Failed

In the case of the above message is prompted, click the Stop icon  a couple of times and make sure that icon  is not available in Task bar. Click “Build” once again, then run simulation.

6.3.9.5.4 Build & Download

It is to build first and then download application from PC to Recorder.

6.3.9.5.5 Download

It is to download application from PC to Recorder

Available options

- i) PC to Recorder via Ethernet
- ii) Removable Disk to Recorder via USB flash disk

PC to Recorder via Ethernet:

- After creating an application, create a build on the PC, and make sure there are no compilation errors.
- Connect Ethernet cable between PC and Recorder
- In editor software, set Environment for Download via Ethernet and enter the IP address of the Recorder. In Environment, Select "Ethernet" at Download, then click the "OK" button.
- In editor software, click "Project", then click "Download" or click the  icon.
- The software will build and transfer the application from the PC to the Recorder. If there are any errors during compilation, they need to be fixed. Once the compilation errors are fixed, please attempt to download again.

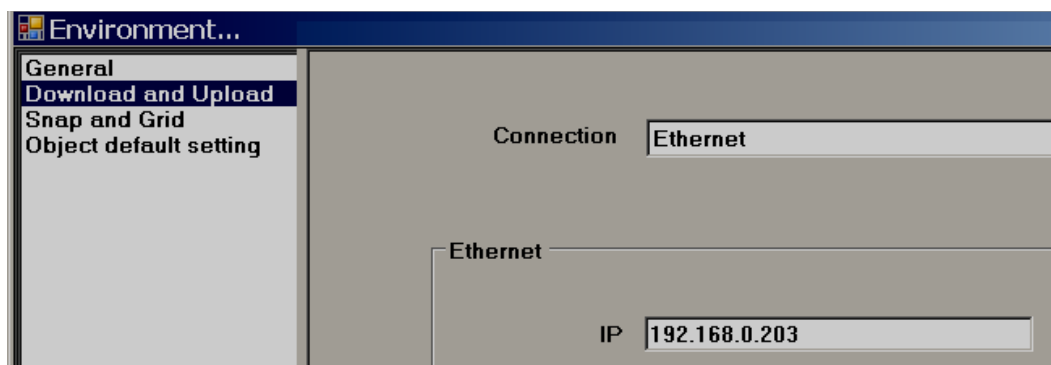

Removable disk to Recorder

- After creating an application, create a build in the PC and make sure there are no compilation errors.
- Connect USB flash disk in to PC via USB port.
- In Recorder editor software, set "Environment" to Download via Removable disk. In Environment, Select "Removable disk" at Download and then, click the "OK" button.
- In Recorder editor software, click "Project", then click "Download" or click at  icon.
- The application will transfer from the PC to the USB flash disk.
- Insert USB flash disk in Recorder.
- Switch on Power to the Recorder. Press "Load", select Path of project files, then press "Load" button near path selection.
- It transfers the application from the USB flash disk to the Recorder.

6.3.9.5.6 Project status

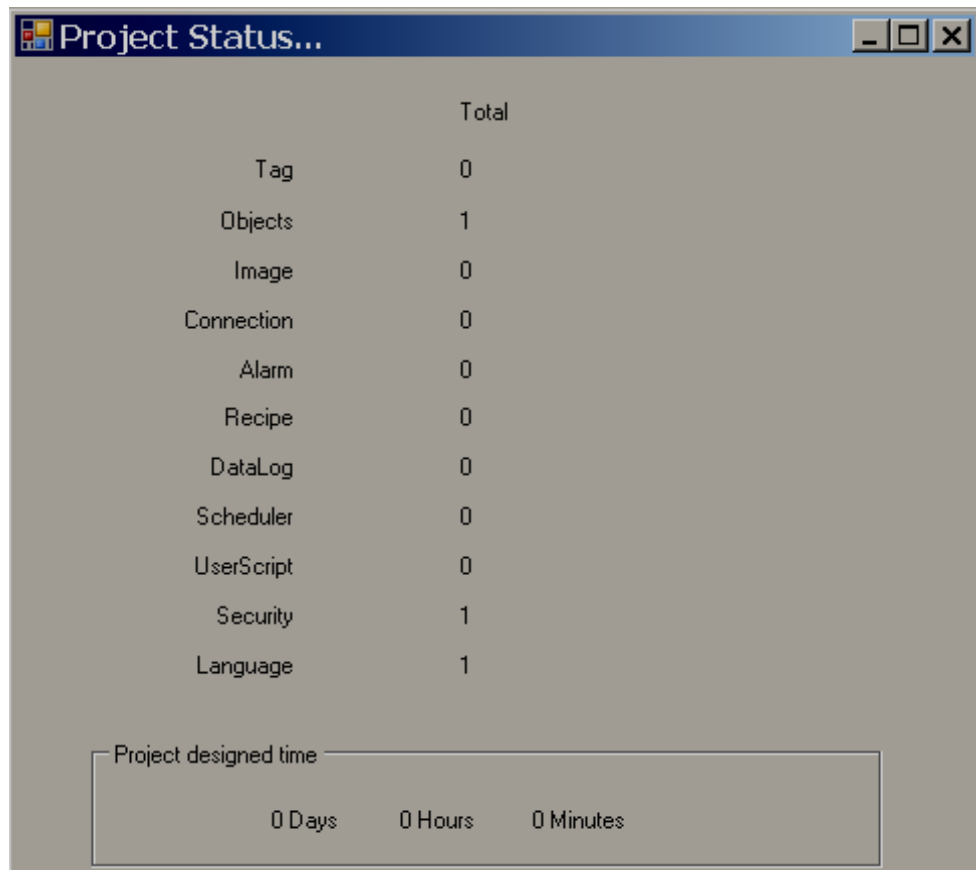

The screenshot shows a window titled "Project Status...". It contains a table with two columns: the first column lists object types, and the second column, labeled "Total", shows the count for each. Below the table is a section labeled "Project designed time" which displays "0 Days 0 Hours 0 Minutes".

	Total
Tag	0
Objects	1
Image	0
Connection	0
Alarm	0
Recipe	0
DataLog	0
Scheduler	0
UserScript	0
Security	1
Language	1

Project designed time
0 Days 0 Hours 0 Minutes

It is used for project management purposes and to know limits and usage of objects.

Project used time: It shows how much time a project has been opened for editing purpose.

7. WEBSERVER

It is used to view Paperless Recorder from a Remote location via Internet.



7.1 Requirements

Item	Minimum Requirements
System	IBM PC compatible computer with Intel Pentium IV or above
Operating System	Windows XP or above
Memory	1 GB
Hard Disk	5 GB Free Space on the hard disk
Communication Ports	Ethernet Port
Browser	Internet Explorer 10 or above, Google Chrome
IP Address	Static IP from Internet Service Provider

Obtain a Static IP address from your Internet service Provider (ISP). This IP address should be unique. Once the IP address is configured in the Recorder, use a Ping Instruction from the DOS prompt first to verify there is successful communication between the Recorder and the PC via Internet.

```
C:\ Command Prompt
Microsoft Windows XP [Version 5.1.2600]
(C) Copyright 1985-2001 Microsoft Corp.

E:\Documents and Settings\Mahi>ping 192.168.0.11

Pinging 192.168.0.11 with 32 bytes of data:

Reply from 192.168.0.11: bytes=32 time<1ms TTL=128
Reply from 192.168.0.11: bytes=32 time<1ms TTL=128
Reply from 192.168.0.11: bytes=32 time<1ms TTL=128
Reply from 192.168.0.11: bytes=32 time<1ms TTL=128

Ping statistics for 192.168.0.11:
    Packets: Sent = 4, Received = 4, Lost = 0 (0% loss),
    Approximate round trip times in milli-seconds:
        Minimum = 0ms, Maximum = 0ms, Average = 0ms

E:\Documents and Settings\Mahi>_
```

7.2 How to configure Web server Settings

For using Web server application in the PPS series Recorder, Configuring the Recorder for a static IP address, and enabling the Web server.

7.2.1 How to Configure Static IP Address

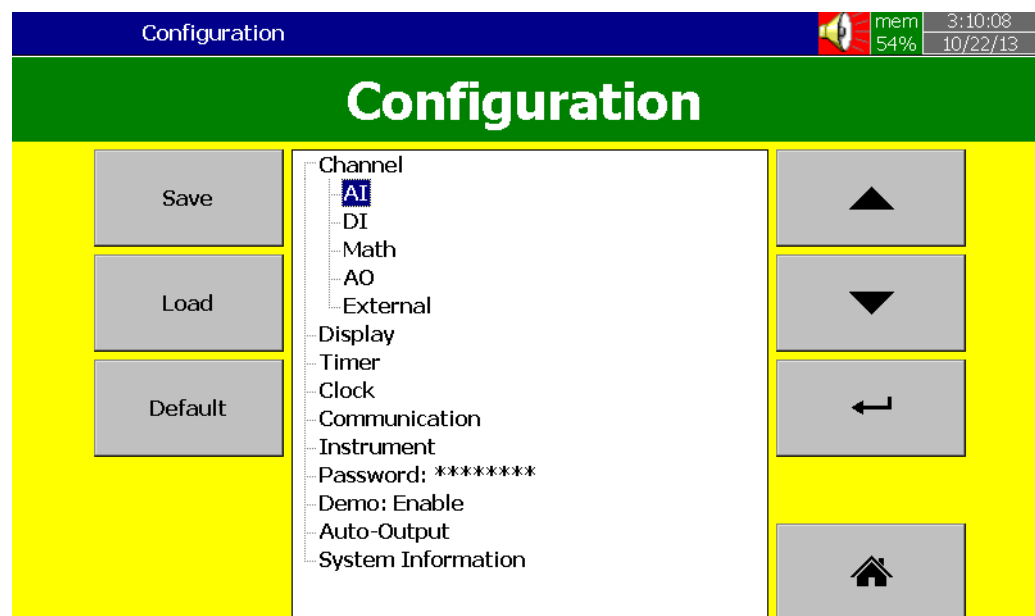

Press  (**Menu**), then **More** and then **Config** soft key to enter Configuration mode. In the Configuration screen, select “Communication”, then press the “Enter” soft key.

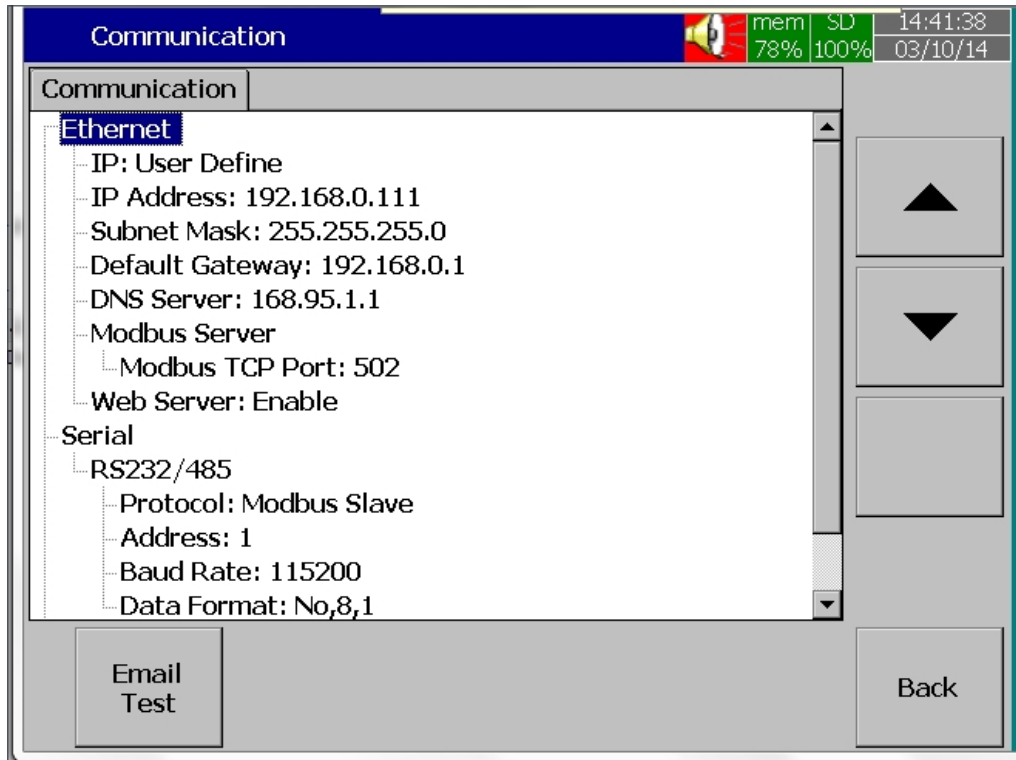

Select IP type = User Define.

Enter the IP Address, Subnet Mask, Default Gateway, and DNS Server Settings in the Ethernet Settings.

Note: Make sure to enter Global, Unique, static fix IP address received from Internet solution provider.

7.2.2 How to Enable Web Server

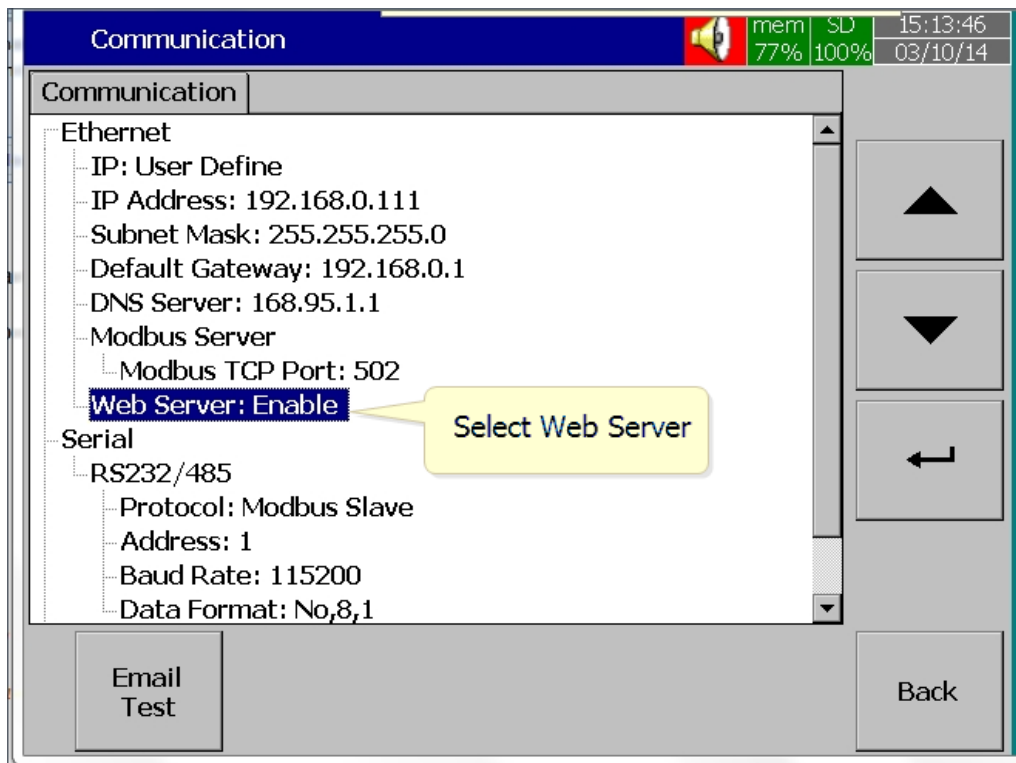

Select Web Server Menu in the Communication screen.

Enable the Web Server for using Web Server application in the Recorder.

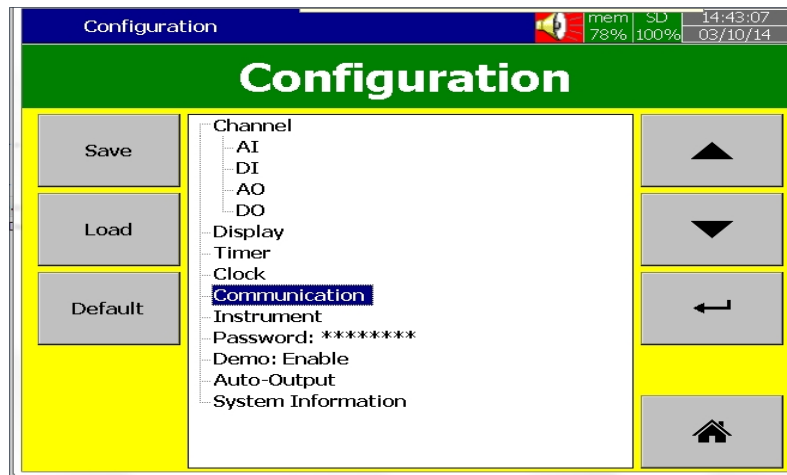

After completing the above steps, press the “Back” key, then the “Home” key to return to the main menu. It will save the configuration settings in the Recorder. Now the Recorder is ready for the Web Server Applications.

Note: The Web Server update time on the browser is 1 second for real time data and statuses and 5 Seconds for Alarms.

7.3 How to View Recorder Data in PC via Webserver:

- ❖ Connect Paperless Recorder to the Internet
- ❖ Open the browser (Internet Explorer 10 or Google Chrome) in the PC

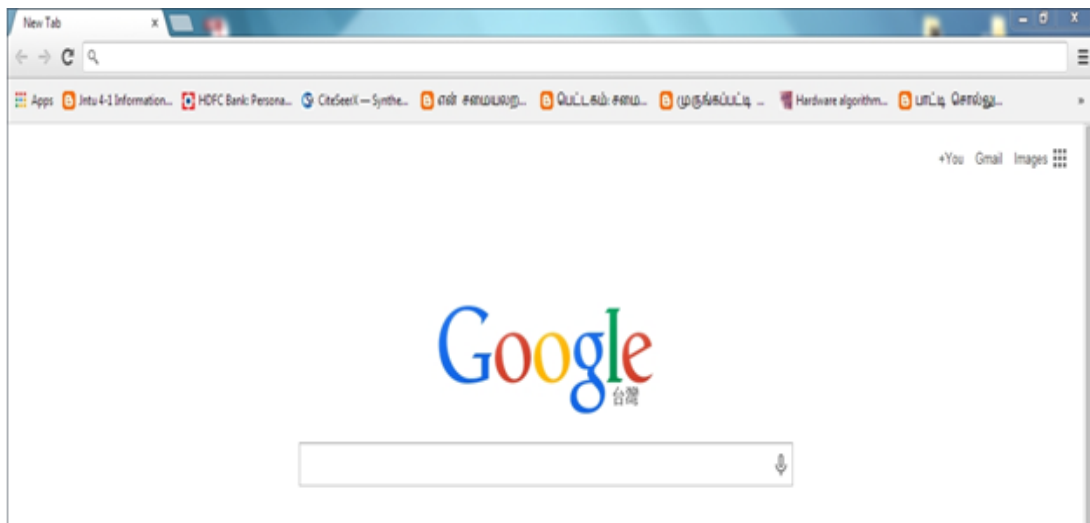

- ❖ Enter the IP address of the Recorder in the address bar of the browser.
Format: <http://192.168.1.111>

❖ Now you can see the Paperless Recorder screens in browser as shown below

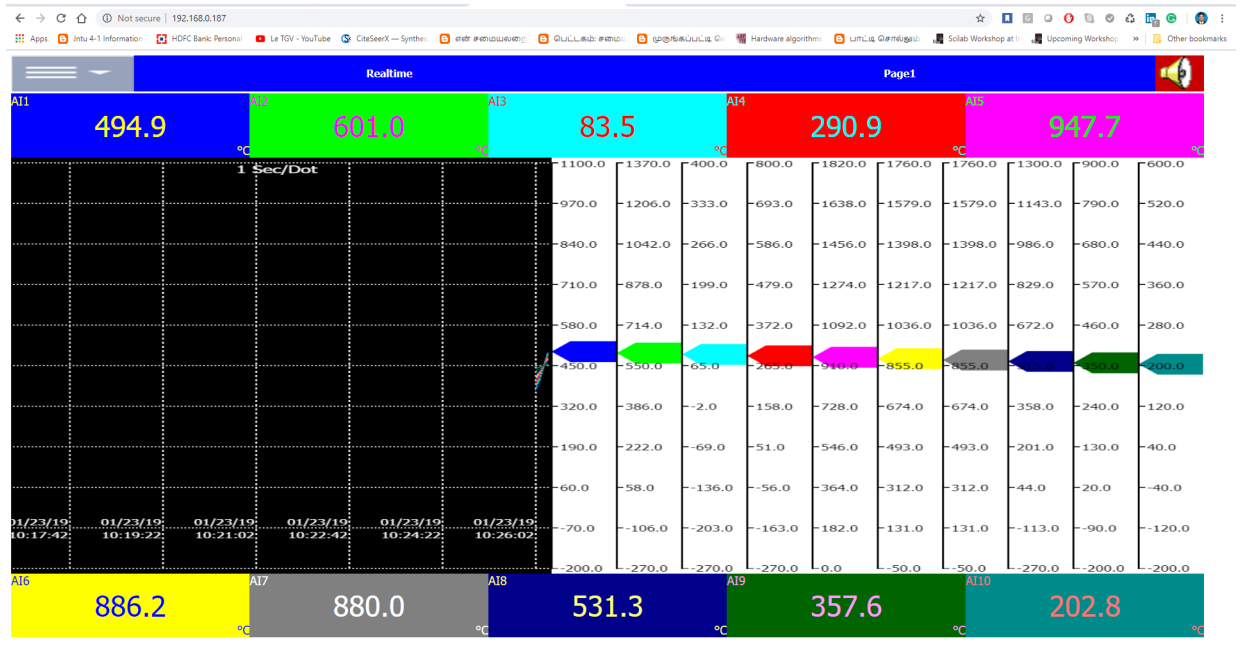

- ❖ The display includes Real time values of all channels like AI, Math, Counters, Totalizers, Real time alarms, historical alarms, status of Digital Inputs, Digital Outputs, Analog Outputs, Counters, and Totalizers etc.
- ❖ Press Real time to select and view the real time display of display pages.

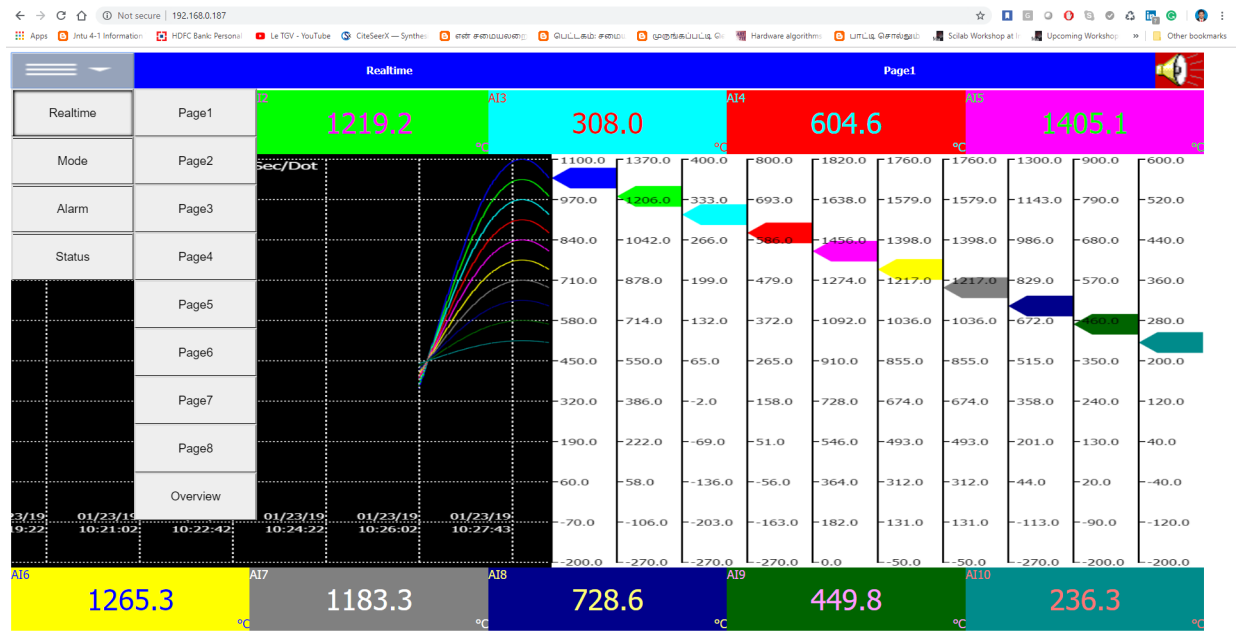

❖ Press Overview to view the summary of all data in single screen



❖ The display mode can be changed by selecting Mode and then select the display mode as Trend, Bar, Digit, Mix, Individual, Circular

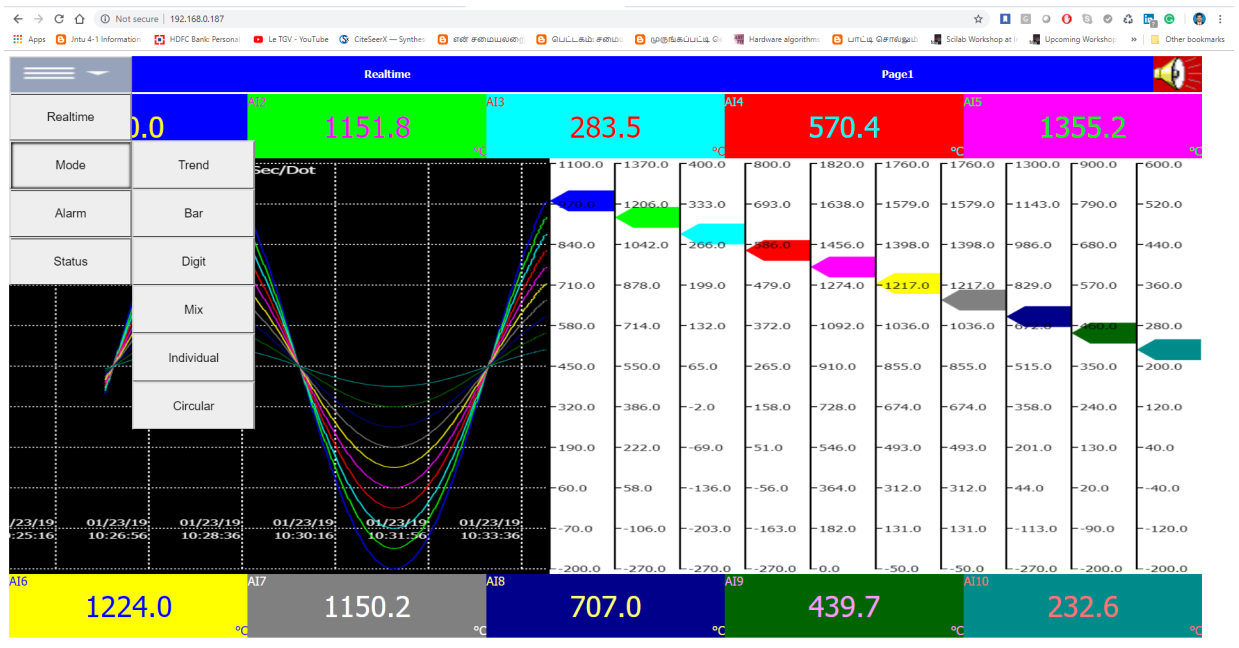

❖ Trend Graph can be viewed by selecting Trend in Mode.

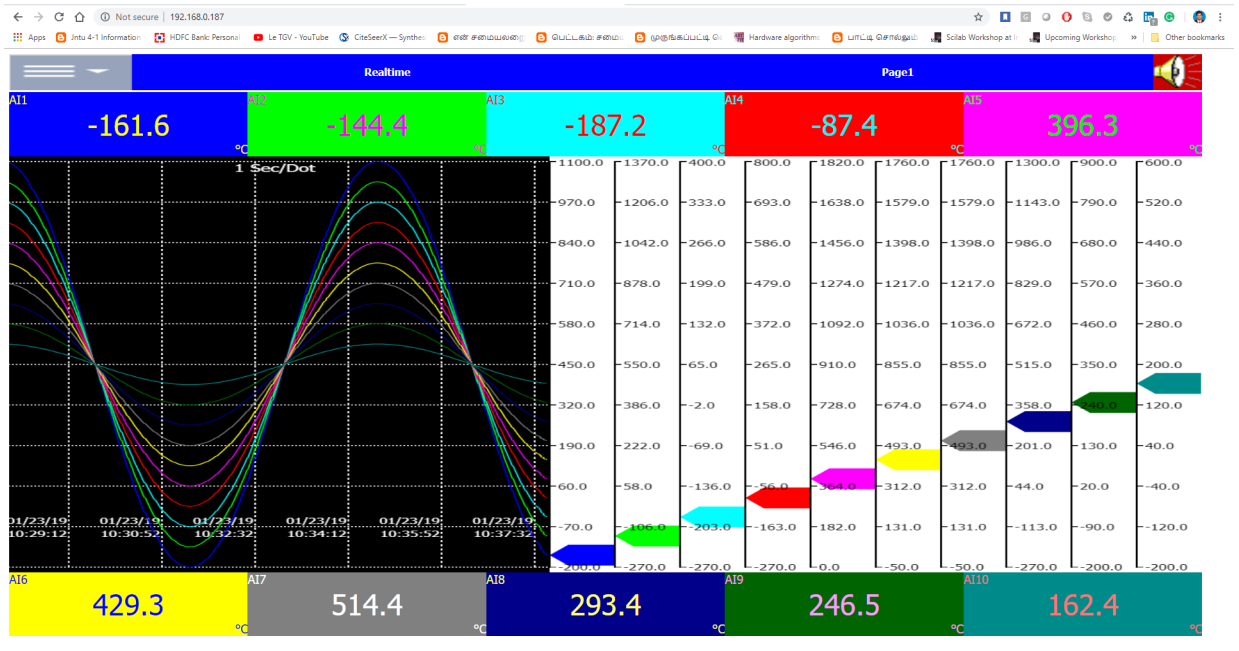

❖ Bar Graph can be viewed by selecting Bar in Mode.

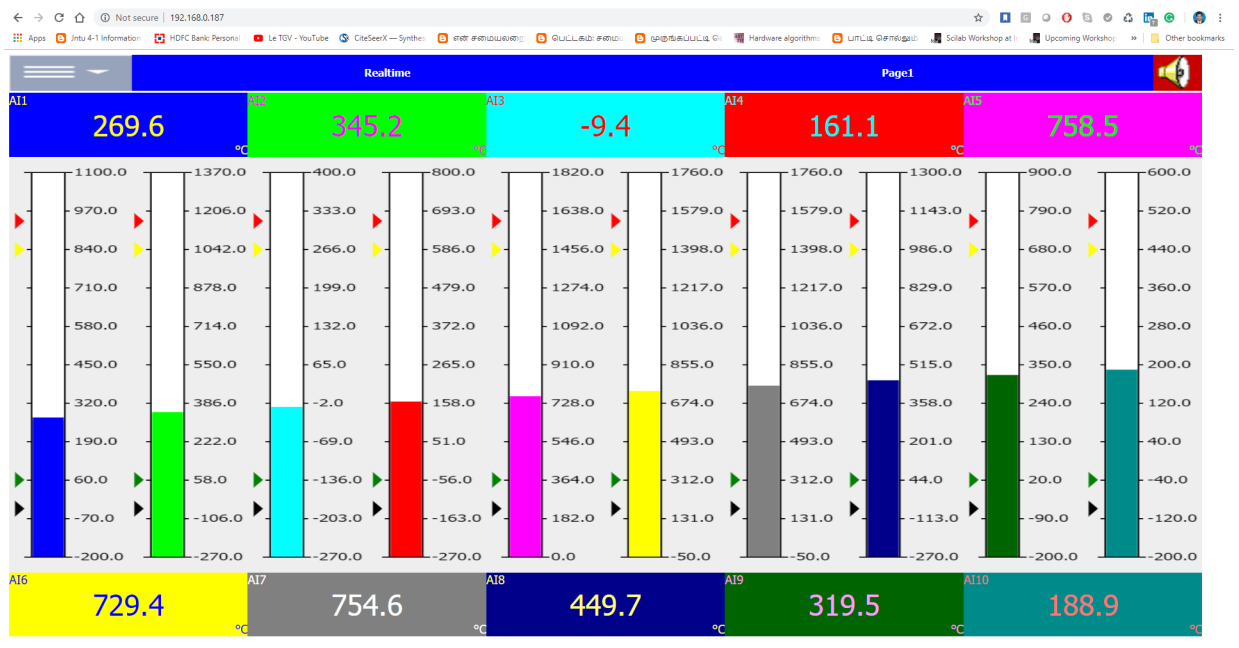

❖ Digital Values format can be viewed by selecting Digit in Mode.

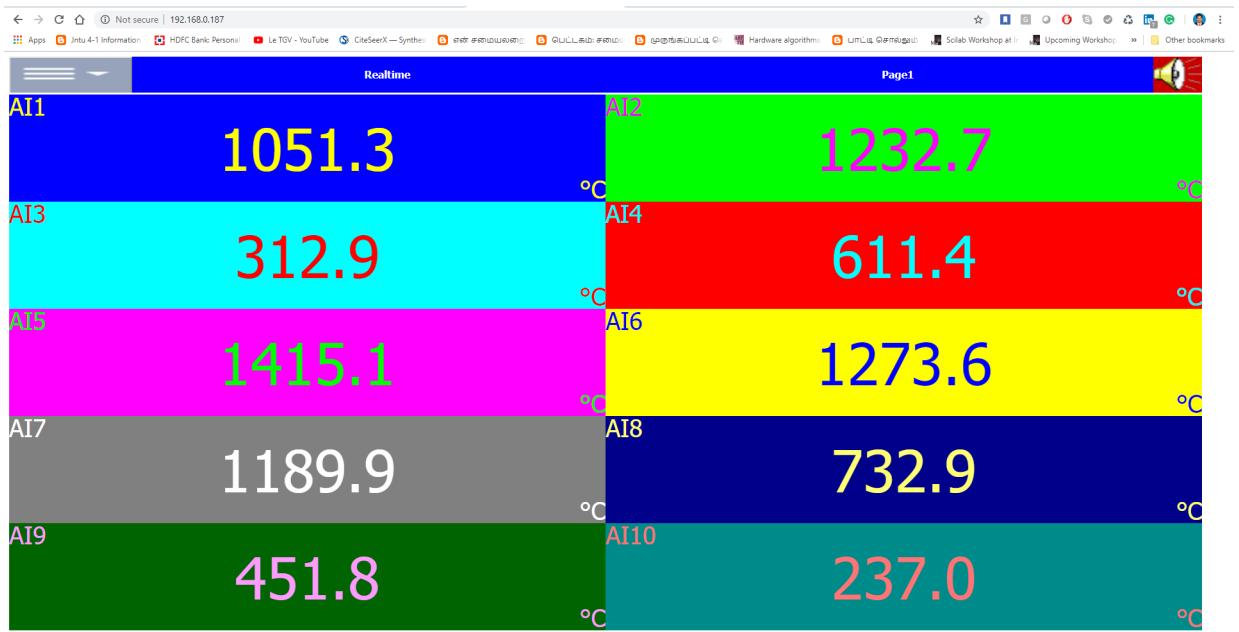

❖ Mixed mode with trend, bar graph and digital format can be viewed by selecting Mix in Mode.

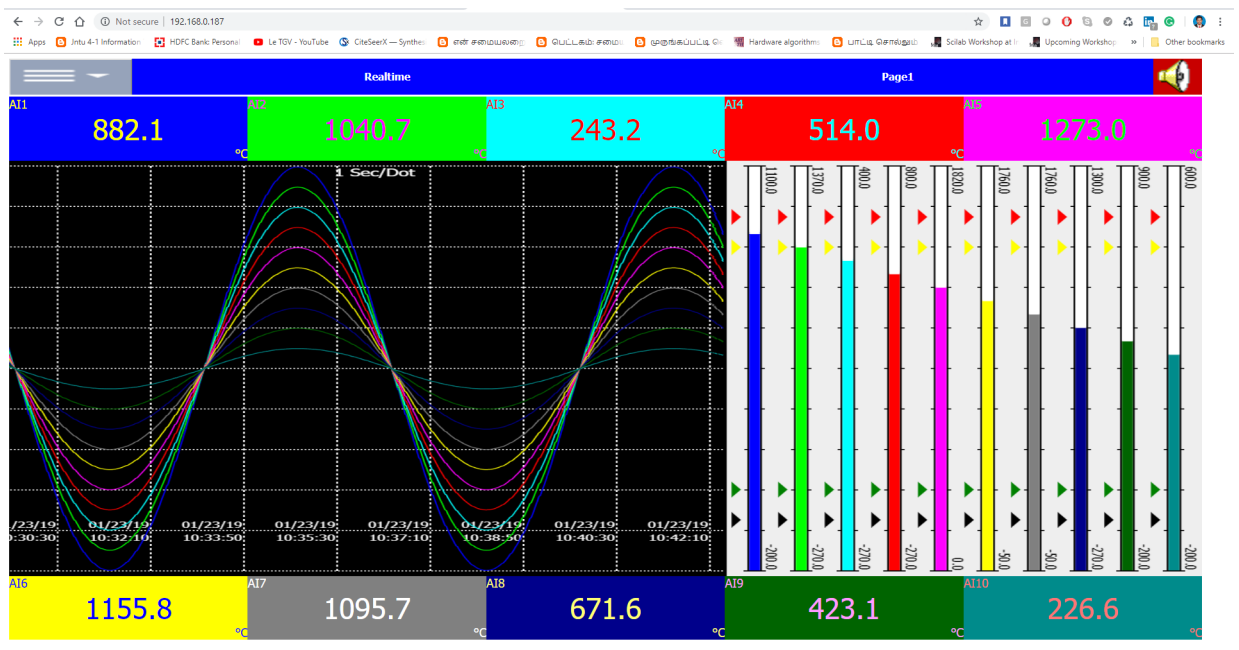

❖ Individual mode with individual trend and scaling can be viewed by selecting Individual in Mode.

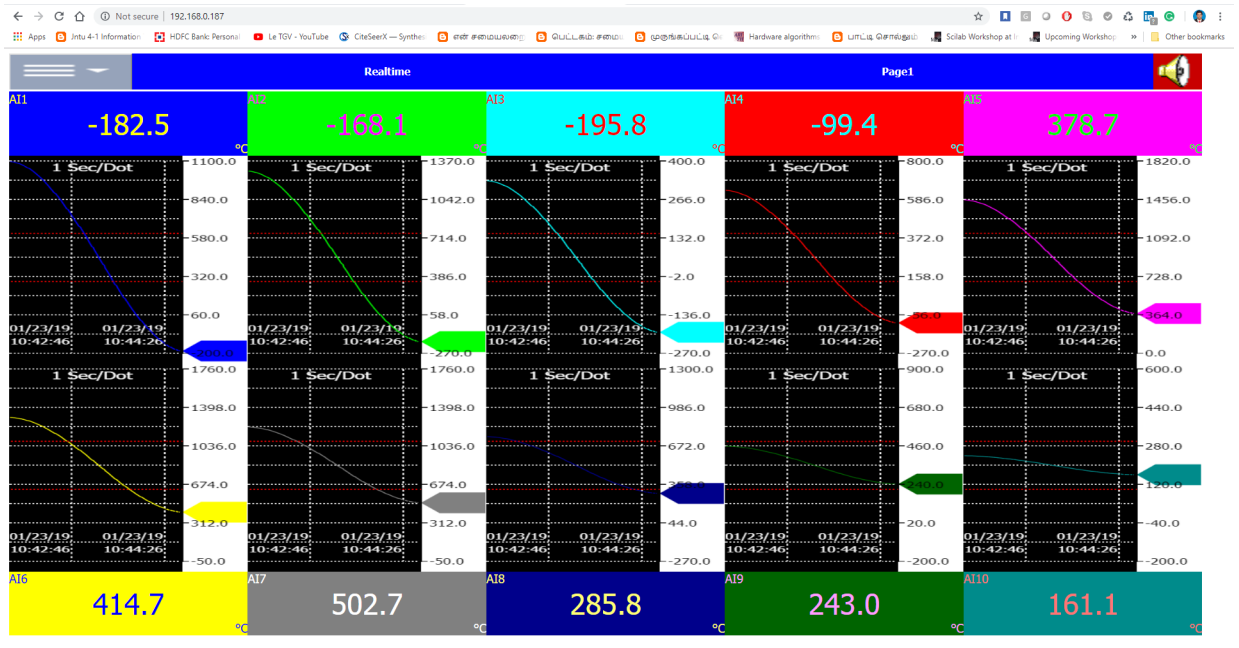

❖ Circular Chart can be viewed by selecting Circular in Mode. It is available only for PPS-3000.

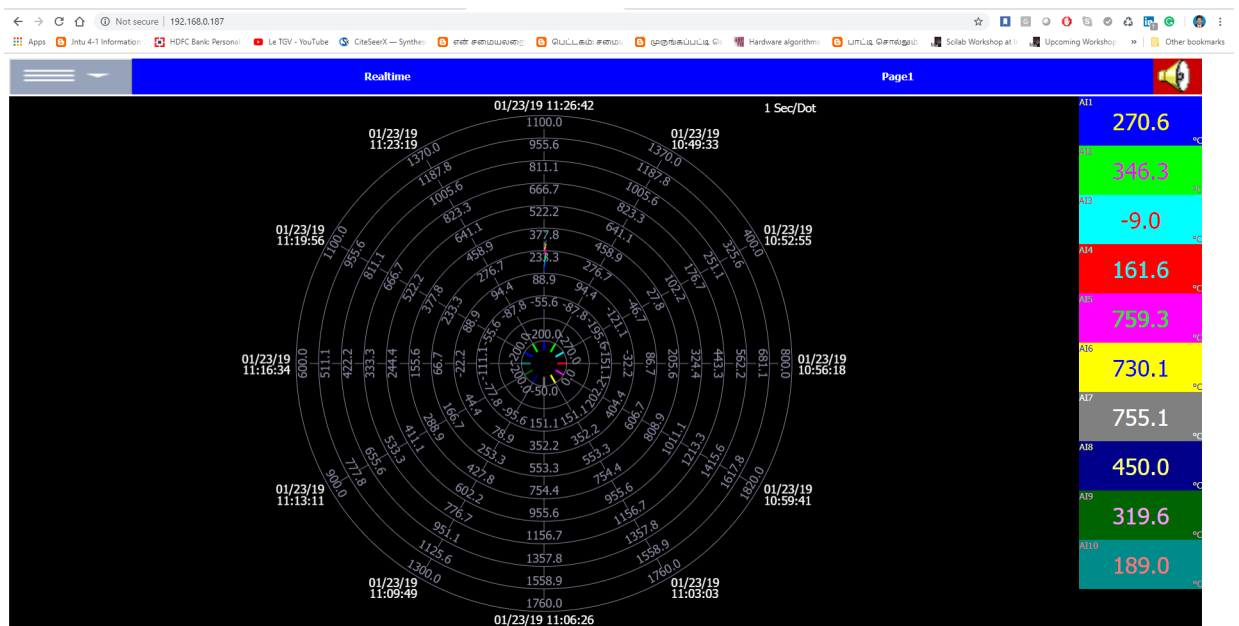

❖ Alarms can be viewed by selecting Alarm in Menu.

No.	Active Time	Acked	Type	Name	Value
1	01/17/19 22:55:18		LoAlarm	AI31	139.51
2	01/17/19 22:55:24		LoAlarm	AI32	135.71
3	01/17/19 22:55:31		LoLoAlarm	AI31	-35.63
4	01/17/19 22:55:31		LoAlarm	AI33	-212.85
5	01/17/19 22:55:37		HiAlarm	AI11	1544.00
6	01/17/19 22:55:40		LoLoAlarm	AI32	-85.99
7	01/17/19 22:55:43		LoAlarm	AI34	-69.86
8	01/17/19 22:55:44		HiAlarm	AI12	1908.04
9	01/17/19 22:55:52		HiHiAlarm	AI11	1719.50
10	01/17/19 22:55:52		HiAlarm	AI13	511.28
11	01/17/19 22:55:55		LoLoAlarm	AI33	-303.32
12	01/17/19 22:56:01		HiHiAlarm	AI12	2329.89
13	01/17/19 22:56:03		HiAlarm	AI14	1087.38
14	01/17/19 22:56:11		HiHiAlarm	AI13	601.49
15	01/17/19 22:56:18		HiAlarm	AI15	2652.80
16	01/17/19 22:56:48		LoAlarm	AI21	-12.00
17	01/17/19 22:56:48		HiAlarm	AI26	80.00
18	01/17/19 22:56:56		LoLoAlarm	AI21	-30.00
19	01/17/19 22:56:56		LoAlarm	AI22	19.40
20	01/17/19 22:56:56		HiHiAlarm	AI26	81.50
21	01/17/19 22:56:56		HiAlarm	AI27	80.00
22	01/17/19 22:56:59		LoAlarm	AI1	59.73
23	01/17/19 22:56:59		LoAlarm	AI41	9.78
24	01/17/19 22:57:05		LoAlarm	AI2	57.62
25	01/17/19 22:57:05		LoAlarm	AI42	49.56
26	01/17/19 22:57:05		LoLoAlarm	AI22	-22.09
27	01/17/19 22:57:05		HiHiAlarm	AI27	87.52
28	01/17/19 22:57:08		LoAlarm	AI23	70.00
29	01/17/19 22:57:08		HiAlarm	AI28	80.00
30	01/17/19 22:57:12		LoLoAlarm	AI1	-37.57
31	01/17/19 22:57:12		LoAlarm	AI3	-136.03
32	01/17/19 22:57:12		LoLoAlarm	AI41	-68.81
33	01/17/19 22:57:12		LoAlarm	AI43	9.95
34	01/17/19 22:57:21		LoLoAlarm	AI2	-65.55
35	01/17/19 22:57:21		LoLoAlarm	AI42	-92.38
36	01/17/19 22:57:24		LoAlarm	AI4	-56.14
37	01/17/19 22:57:24		LoAlarm	AI44	69.75
38	01/17/19 22:57:36		LoLoAlarm	AI3	-186.29
39	01/17/19 22:57:36		LoLoAlarm	AI43	-68.81
40	01/17/19 22:57:59		LoAlarm	AI5	364.00
41	01/17/19 22:57:59		LoAlarm	AI45	19.00
42	01/17/19 22:58:41		HiAlarm	AI31	1544.40

❖ Status of Analog Outputs, Digital Inputs, Digital Outputs, Totalizers, Counters can be viewed by selecting status in Menu

No.	DI	DO	AO	Counter	Totalizer	Value	Description
1	DI1					LOW	
2	DI2					0	
3	DI3					LOW	
4	DI4					0	
5	DI5					LOW	
6	DI6					0	
7	DI7					LOW	
8	DI8					0	
9	DI9					LOW	
10	DI10					0	
11	DI11					LOW	
12	DI12					0	

Not secure | 192.168.0.187/#

Apps | Jntu 4-1 Information | HDFC Bank Personal | Le TV - YouTube | CiteSeerX - Synthe | ... | Hardware algorithm | ... | Slab Workshop at | ... | Upcoming Worksho | ... | Other bookmarks

Status DO

DI	DO	AO	Counter	Totalizer	No.	Name	Value	Description
1					1	DO1	OFF	
2					2	DO2	OFF	
3					3	DO3	OFF	
4					4	DO4	OFF	
5					5	DO5	OFF	
6					6	DO6	OFF	
7					7	DO7	OFF	
8					8	DO8	OFF	
9					9	DO9	OFF	
10					10	DO10	OFF	
11					11	DO11	OFF	
12					12	DO12	OFF	

Not secure | 192.168.0.187/#

Apps | Jntu 4-1 Information | HDFC Bank Personal | Le TV - YouTube | CiteSeerX - Synthe | ... | Hardware algorithm | ... | Slab Workshop at | ... | Upcoming Worksho | ... | Other bookmarks

Status AO

DI	DO	AO	Counter	Totalizer	No.	Name	Value	Description
1					1	AO1	6.016	
2					2	AO2	6.614	
3					3	AO3	7.213	
4					4	AO4	7.811	
5					5	AO5	8.409	
6					6	AO6	9.008	
7					7	AO7	9.606	
8					8	AO8	10.205	
9					9	AO9	10.803	
10					10	AO10	11.402	
11					11	AO11	8.304	
12					12	AO12	8.674	

Not secure | 192.168.0.187/#

Apps Jintu 4-1 Information HDFC Bank Personal Le TVG - YouTube CineSeerX - Synthe: என் #எழுப்புவேடு: @LULLL#ஃ #எழுப்ப: @முத்துசுள்ளுLULLL: Hardware algorithm: லுLUL: @#நீடு: Scilab Workshop at: Upcoming Worksho: Other bookmarks

Status Counter

DI	DO	AO	Counter	Totalizer	
No.			Name	Value	Description
1			Counter1	0	
2			Counter2	0	
3			Counter3	0	
4			Counter4	0	
5			Counter5	0	
6			Counter6	0	
7			Counter7	0	
8			Counter8	0	
9			Counter9	0	
10			Counter10	0	
11			Counter11	0	
12			Counter12	0	
13			Counter13	0	
14			Counter14	0	
15			Counter15	0	
16			Counter16	0	
17			Counter17	0	
18			Counter18	0	
19			Counter19	0	
20			Counter20	0	

Not secure | 192.168.0.187/#

Apps Jintu 4-1 Information HDFC Bank Personal Le TVG - YouTube CineSeerX - Synthe: என் #எழுப்புவேடு: @LULLL#ஃ #எழுப்ப: @முத்துசுள்ளுLULLL: Hardware algorithm: லுLUL: @#நீடு: Scilab Workshop at: Upcoming Worksho: Other bookmarks

Status Totalizer

DI	DO	AO	Counter	Totalizer	
No.			Name	Value	Description
1			Totalizer1	1.120E+18	
2			Totalizer2	9.859E+17	
3			Totalizer3	2.378E+16	
4			Totalizer4	446918228.6	
5			Totalizer5	1013251977.2	
6			Totalizer6	929962252.0	
7			Totalizer7	918672302.6	
8			Totalizer8	569679622.7	
9			Totalizer9	400314655.7	
10			Totalizer10	246347103.8	
11			Totalizer11	133227233.1	
12			Totalizer12	221365105.7	
13			Totalizer13	93021670.7	
14			Totalizer14	93023882.0	
15			Totalizer15	93026093.3	
16			Totalizer16	60687991.8	
17			Totalizer17	60685780.6	
18			Totalizer18	60683569.2	
19			Totalizer19	44897057.2	
20			Totalizer20	38991518.6	

8. Modbus Communication

8.1 Modbus Address Mapping

8.1.1 Input Register (3xxxxx) Parameter Table for Modbus RTU Slave / TCP Server

8.1.1.1 AI / DI / DO / AO Channel Data (Integer Type)

Modbus Address	Notation	Register Name	Access
1	Reserve	Reserve	R
2	AI1	AI 1 process value	R
3	AI2	AI 2 process value	R
4	AI3	AI 3 process value	R
5	AI4	AI 4 process value	R
6	AI5	AI 5 process value	R
7	AI6	AI 6 process value	R
8	AI7	AI 7 process value	R
9	AI8	AI 8 process value	R
10	AI9	AI 9 process value	R
11	AI10	AI 10 process value	R
12	AI11	AI 11 process value	R
13	AI12	AI 12 process value	R
14	AI13	AI 13 process value	R
15	AI14	AI 14 process value	R
16	AI15	AI 15 process value	R
17	AI16	AI 16 process value	R
18	AI17	AI 17 process value	R
19	AI18	AI 18 process value	R
20	AI19	AI 19 process value	R
21	AI20	AI 20 process value	R
22	AI21	AI 21 process value	R
23	AI22	AI 22 process value	R
24	AI23	AI 23 process value	R
25	AI24	AI 24 process value	R
26	AI25	AI 25 process value	R
27	AI26	AI 26 process value	R
28	AI27	AI 27 process value	R
29	AI28	AI 28 process value	R
30	AI29	AI 29 process value	R
31	AI30	AI 30 process value	R
32	AI31	AI 31 process value	R
33	AI32	AI 32 process value	R
34	AI33	AI 33 process value	R
35	AI34	AI 34 process value	R
36	AI35	AI 35 process value	R
37	AI36	AI 36 process value	R
38	AI37	AI 37 process value	R
39	AI38	AI 38 process value	R
40	AI39	AI 39 process value	R
41	AI40	AI 40 process value	R
42	AI41	AI 41 process value	R
43	AI42	AI 42 process value	R
44	AI43	AI 43 process value	R
45	AI44	AI 44 process value	R
46	AI45	AI 45 process value	R
47	AI46	AI 46 process value	R
48	AI47	AI 47 process value	R

Modbus Address	Notation	Register Name	Access
49	AI48	AI 48 process value	R
50	DI1	DI 1 process value	R
51	DI2	DI 2 process value	R
52	DI3	DI 3 process value	R
53	DI4	DI 4 process value	R
54	DI5	DI 5 process value	R
55	DI6	DI 6 process value	R
56	DI7	DI 7 process value	R
57	DI8	DI 8 process value	R
58	DI9	DI 9 process value	R
59	DI10	DI 10 process value	R
60	DI11	DI 11 process value	R
61	DI12	DI 12 process value	R
62	DI13	DI 13 process value	R
63	DI14	DI 14 process value	R
64	DI15	DI 15 process value	R
65	DI16	DI 16 process value	R
66	DI17	DI 17 process value	R
67	DI18	DI 18 process value	R
68	DI19	DI 19 process value	R
69	DI20	DI 20 process value	R
70	DI21	DI 21 process value	R
71	DI22	DI 22 process value	R
72	DI23	DI 23 process value	R
73	DI24	DI 24 process value	R
74	DO1	DO 1 process value	R
75	DO2	DO 2 process value	R
76	DO3	DO 3 process value	R
77	DO4	DO 4 process value	R
78	DO5	DO 5 process value	R
79	DO6	DO 6 process value	R
80	DO7	DO 7 process value	R
81	DO8	DO 8 process value	R
82	DO9	DO 9 process value	R
83	DO10	DO 10 process value	R
84	DO11	DO 11 process value	R
85	DO12	DO 12 process value	R
86	DO13	DO 13 process value	R
87	DO14	DO 14 process value	R
88	DO15	DO 15 process value	R
89	DO16	DO 16 process value	R
90	DO17	DO 17 process value	R
91	DO18	DO 18 process value	R
92	DO19	DO 19 process value	R
93	DO20	DO 20 process value	R
94	DO21	DO 21 process value	R
95	DO22	DO 22 process value	R
96	DO23	DO 23 process value	R
97	DO24	DO 24 process value	R
98	AO1	AO 1 process value	R
99	AO2	AO 2 process value	R
100	AO3	AO 3 process value	R
101	AO4	AO 4 process value	R
102	AO5	AO 5 process value	R
103	AO6	AO 6 process value	R
104	AO7	AO 7 process value	R

Modbus Address	Notation	Register Name	Access
105	AO8	AO 8 process value	R
106	AO9	AO 9 process value	R
107	AO10	AO 10 process value	R
108	AO11	AO 11 process value	R
109	AO12	AO 12 process value	R

Note: If the register value is 65534, then there is a communication error.

8.1.1.2 AI / DI / DO / AO Channel Data (Float Type)

Modbus Address	Notation	Register Name	Access
1001	Reserve	Reserve	R
1003	AI1	AI 1 process value	R
1005	AI2	AI 2 process value	R
1007	AI3	AI 3 process value	R
1009	AI4	AI 4 process value	R
1011	AI5	AI 5 process value	R
1013	AI6	AI 6 process value	R
1015	AI7	AI 7 process value	R
1017	AI8	AI 8 process value	R
1019	AI9	AI 9 process value	R
1021	AI10	AI 10 process value	R
1023	AI11	AI 11 process value	R
1025	AI12	AI 12 process value	R
1027	AI13	AI 13 process value	R
1029	AI14	AI 14 process value	R
1031	AI15	AI 15 process value	R
1033	AI16	AI 16 process value	R
1035	AI17	AI 17 process value	R
1037	AI18	AI 18 process value	R
1039	AI19	AI 19 process value	R
1041	AI20	AI 20 process value	R
1043	AI21	AI 21 process value	R
1045	AI22	AI 22 process value	R
1047	AI23	AI 23 process value	R
1049	AI24	AI 24 process value	R
1051	AI25	AI 25 process value	R
1053	AI26	AI 26 process value	R
1055	AI27	AI 27 process value	R
1057	AI28	AI 28 process value	R
1059	AI29	AI 29 process value	R
1061	AI30	AI 30 process value	R
1063	AI31	AI 31 process value	R
1065	AI32	AI 32 process value	R
1067	AI33	AI 33 process value	R
1069	AI34	AI 34 process value	R
1071	AI35	AI 35 process value	R
1073	AI36	AI 36 process value	R
1075	AI37	AI 37 process value	R
1077	AI38	AI 38 process value	R
1079	AI39	AI 39 process value	R
1081	AI40	AI 40 process value	R
1083	AI41	AI 41 process value	R
1085	AI42	AI 42 process value	R
1087	AI43	AI 43 process value	R

Modbus Address	Notation	Register Name	Access
1089	AI44	AI 44 process value	R
1091	AI45	AI 45 process value	R
1093	AI46	AI 46 process value	R
1095	AI47	AI 47 process value	R
1097	AI48	AI 48 process value	R
1099	DI1	DI 1 process value	R
1101	DI2	DI 2 process value	R
1103	DI3	DI 3 process value	R
1105	DI4	DI 4 process value	R
1107	DI5	DI 5 process value	R
1109	DI6	DI 6 process value	R
1111	DI7	DI 7 process value	R
1113	DI8	DI 8 process value	R
1115	DI9	DI 9 process value	R
1117	DI10	DI 10 process value	R
1119	DI11	DI 11 process value	R
1121	DI12	DI 12 process value	R
1123	DI13	DI 13 process value	R
1125	DI14	DI 14 process value	R
1127	DI15	DI 15 process value	R
1129	DI16	DI 16 process value	R
1131	DI17	DI 17 process value	R
1133	DI18	DI 18 process value	R
1135	DI19	DI 19 process value	R
1137	DI20	DI 20 process value	R
1139	DI21	DI 21 process value	R
1141	DI22	DI 22 process value	R
1143	DI23	DI 23 process value	R
1145	DI24	DI 24 process value	R
1147	DO1	DO 1 process value	R
1149	DO2	DO 2 process value	R
1151	DO3	DO 3 process value	R
1153	DO4	DO 4 process value	R
1155	DO5	DO 5 process value	R
1157	DO6	DO 6 process value	R
1159	DO7	DO 7 process value	R
1161	DO8	DO 8 process value	R
1163	DO9	DO 9 process value	R
1165	DO10	DO 10 process value	R
1167	DO11	DO 11 process value	R
1169	DO12	DO 12 process value	R
1171	DO13	DO 13 process value	R
1173	DO14	DO 14 process value	R
1175	DO15	DO 15 process value	R
1177	DO16	DO 16 process value	R
1179	DO17	DO 17 process value	R
1181	DO18	DO 18 process value	R
1183	DO19	DO 19 process value	R
1185	DO20	DO 20 process value	R
1187	DO21	DO 21 process value	R
1189	DO22	DO 22 process value	R
1191	DO23	DO 23 process value	R
1193	DO24	DO 24 process value	R
1195	AO1	AO 1 process value	R
1197	AO2	AO 2 process value	R
1199	AO3	AO 3 process value	R

Modbus Address	Notation	Register Name	Access
1201	AO4	AO 4 process value	R
1203	AO5	AO 5 process value	R
1205	AO6	AO 6 process value	R
1207	AO7	AO 7 process value	R
1209	AO8	AO 8 process value	R
1211	AO9	AO 9 process value	R
1213	AO10	AO 10 process value	R
1215	AO11	AO 11 process value	R
1217	AO12	AO 12 process value	R

Note: If the register value is 3.0+E38, then there is a communication error.

8.1.1.3 Math Channel Data (Integer Type)

Modbus Address	Notation	Register Name	Access
201	Math1	Math 1 process value high word	R
202	Math1	Math 1 process value low word	R
203	Math2	Math 2 process value high word	R
204	Math2	Math 2 process value low word	R
205	Math3	Math 3 process value high word	R
206	Math3	Math 3 process value low word	R
207	Math4	Math 4 process value high word	R
208	Math4	Math 4 process value low word	R
209	Math5	Math 5 process value high word	R
210	Math5	Math 5 process value low word	R
211	Math6	Math 6 process value high word	R
212	Math6	Math 6 process value low word	R
213	Math7	Math 7 process value high word	R
214	Math7	Math 7 process value low word	R
215	Math8	Math 8 process value high word	R
216	Math8	Math 8 process value low word	R
217	Math9	Math 9 process value high word	R
218	Math9	Math 9 process value low word	R
219	Math10	Math 10 process value high word	R
220	Math10	Math 10 process value low word	R
221	Math11	Math 11 process value high word	R
222	Math11	Math 11 process value low word	R
223	Math12	Math 12 process value high word	R
224	Math12	Math 12 process value low word	R
225	Math13	Math 13 process value high word	R
226	Math13	Math 13 process value low word	R
227	Math14	Math 14 process value high word	R
228	Math14	Math 14 process value low word	R
229	Math15	Math 15 process value high word	R
230	Math15	Math 15 process value low word	R
231	Math16	Math 16 process value high word	R
232	Math16	Math 16 process value low word	R
233	Math17	Math 17 process value high word	R
234	Math17	Math 17 process value low word	R
235	Math18	Math 18 process value high word	R
236	Math18	Math 18 process value low word	R
237	Math19	Math 19 process value high word	R
238	Math19	Math 19 process value low word	R
239	Math20	Math 20 process value high word	R
240	Math20	Math 20 process value low word	R

Modbus Address	Notation	Register Name	Access
241	Math21	Math 21 process value high word	R
242	Math21	Math 21 process value low word	R
243	Math22	Math 22 process value high word	R
244	Math22	Math 22 process value low word	R
245	Math23	Math 23 process value high word	R
246	Math23	Math 23 process value low word	R
247	Math24	Math 24 process value high word	R
248	Math24	Math 24 process value low word	R
249	Math25	Math 25 process value high word	R
250	Math25	Math 25 process value low word	R
251	Math26	Math 26 process value high word	R
252	Math26	Math 26 process value low word	R
253	Math27	Math 27 process value high word	R
254	Math27	Math 27 process value low word	R
255	Math28	Math 28 process value high word	R
256	Math28	Math 28 process value low word	R
257	Math29	Math 29 process value high word	R
258	Math29	Math 29 process value low word	R
259	Math30	Math 30 process value high word	R
260	Math30	Math 30 process value low word	R
261	Math31	Math 31 process value high word	R
262	Math31	Math 31 process value low word	R
263	Math32	Math 32 process value high word	R
264	Math32	Math 32 process value low word	R
265	Math33	Math 33 process value high word	R
266	Math33	Math 33 process value low word	R
267	Math34	Math 34 process value high word	R
268	Math34	Math 34 process value low word	R
269	Math35	Math 35 process value high word	R
270	Math35	Math 35 process value low word	R
271	Math36	Math 36 process value high word	R
272	Math36	Math 36 process value low word	R
273	Math37	Math 37 process value high word	R
274	Math37	Math 37 process value low word	R
275	Math38	Math 38 process value high word	R
276	Math38	Math 38 process value low word	R
277	Math39	Math 39 process value high word	R
278	Math39	Math 39 process value low word	R
279	Math40	Math 40 process value high word	R
280	Math40	Math 40 process value low word	R
281	Math41	Math 41 process value high word	R
282	Math41	Math 41 process value low word	R
283	Math42	Math 42 process value high word	R
284	Math42	Math 42 process value low word	R
285	Math43	Math 43 process value high word	R
286	Math43	Math 43 process value low word	R
287	Math44	Math 44 process value high word	R
288	Math44	Math 44 process value low word	R
289	Math45	Math 45 process value high word	R
290	Math45	Math 45 process value low word	R
291	Math46	Math 46 process value high word	R
292	Math46	Math 46 process value low word	R
293	Math47	Math 47 process value high word	R
294	Math47	Math 47 process value low word	R
295	Math48	Math 48 process value high word	R
296	Math48	Math 48 process value low word	R

Modbus Address	Notation	Register Name	Access
297	Math49	Math 49 process value high word	R
298	Math49	Math 49 process value low word	R
299	Math50	Math 50 process value high word	R
300	Math50	Math 50 process value low word	R
301	Math51	Math 51 process value high word	R
302	Math51	Math 51 process value low word	R
303	Math52	Math 52 process value high word	R
304	Math52	Math 52 process value low word	R
305	Math53	Math 53 process value high word	R
306	Math53	Math 53 process value low word	R
307	Math54	Math 54 process value high word	R
308	Math54	Math 54 process value low word	R
309	Math55	Math 55 process value high word	R
310	Math55	Math 55 process value low word	R
311	Math56	Math 56 process value high word	R
312	Math56	Math 56 process value low word	R
313	Math57	Math 57 process value high word	R
314	Math57	Math 57 process value low word	R
315	Math58	Math 58 process value high word	R
316	Math58	Math 58 process value low word	R
317	Math59	Math 59 process value high word	R
318	Math59	Math 59 process value low word	R
319	Math60	Math 60 process value high word	R
320	Math60	Math 60 process value low word	R

Note: If the register value is 4294967294, then there is a communication error.

8.1.1.4 Math Channel Data (Float Type)

Modbus Address	Notation	Register Name	Access
1401	Math1	Math 1 process value	R
1403	Math2	Math 2 process value	R
1405	Math3	Math 3 process value	R
1407	Math4	Math 4 process value	R
1409	Math5	Math 5 process value	R
1411	Math6	Math 6 process value	R
1413	Math7	Math 7 process value	R
1415	Math8	Math 8 process value	R
1417	Math9	Math 9 process value	R
1419	Math10	Math 10 process value	R
1421	Math11	Math 11 process value	R
1423	Math12	Math 12 process value	R
1425	Math13	Math 13 process value	R
1427	Math14	Math 14 process value	R
1429	Math15	Math 15 process value	R
1431	Math16	Math 16 process value	R
1433	Math17	Math 17 process value	R
1435	Math18	Math 18 process value	R
1437	Math19	Math 19 process value	R
1439	Math20	Math 20 process value	R
1441	Math21	Math 21 process value	R
1443	Math22	Math 22 process value	R
1445	Math23	Math 23 process value	R
1447	Math24	Math 24 process value	R
1449	Math25	Math 25 process value	R

Modbus Address	Notation	Register Name	Access
1451	Math26	Math 26 process value	R
1453	Math27	Math 27 process value	R
1455	Math28	Math 28 process value	R
1457	Math29	Math 29 process value	R
1459	Math30	Math 30 process value	R
1461	Math31	Math 31 process value	R
1463	Math32	Math 32 process value	R
1465	Math33	Math 33 process value	R
1467	Math34	Math 34 process value	R
1469	Math35	Math 35 process value	R
1471	Math36	Math 36 process value	R
1473	Math37	Math 37 process value	R
1475	Math38	Math 38 process value	R
1477	Math39	Math 39 process value	R
1479	Math40	Math 40 process value	R
1481	Math41	Math 41 process value	R
1483	Math42	Math 42 process value	R
1485	Math43	Math 43 process value	R
1487	Math44	Math 44 process value	R
1489	Math45	Math 45 process value	R
1491	Math46	Math 46 process value	R
1493	Math47	Math 47 process value	R
1495	Math48	Math 48 process value	R
1497	Math49	Math 49 process value	R
1499	Math50	Math 50 process value	R
1501	Math51	Math 51 process value	R
1503	Math52	Math 52 process value	R
1505	Math53	Math 53 process value	R
1507	Math54	Math 54 process value	R
1509	Math55	Math 55 process value	R
1511	Math56	Math 56 process value	R
1513	Math57	Math 57 process value	R
1515	Math58	Math 58 process value	R
1517	Math59	Math 59 process value	R
1519	Math60	Math 60 process value	R

Note: If the register value is 3.0+E38, then there is a communication error.

8.1.1.5 PID Process Control Module Data (Integer Type)

Modbus Address	Notation	Register Name	Access
401	C1_PV	Current process value	R
402	C1_SV	Current set point Value	R
403	C1_PVMD	PV mode selection ¹ 0 : PV1 1 : PV2 2 : PV1 - 2 3 : PV2 - 1	R
404	C1_IN1U	IN1 unit selection ² 0 : °C 1 : °F 2 : PU	R
405	C1_IN2U	IN2 unit selection ³ 0 : °C 1 : °F 2 : PU	R
406	C1_MV1	Current output 1 value	R

Modbus Address	Notation	Register Name	Access
407	C1_MV2	Current output 2 value	R
408	C1_ALM	Contains conditional code of parameters' resolution and current alarm status ⁴	R
409	C1_ERROR	Current error code ⁵	R
410	C1_SPMD	Set point mode selection ⁶ 0 : SP1.2 1 : MIN.R 2 : HR.R 3 : PV1 4 : PV2 5 : PUMP	R
411	C1_EIFN	Event input function ⁷ 0 : None 1 : SP2 2 : PID2 3 : SP.P2 4 : RS.A1 5 : RS.A2 6 : R.A1.2 7 : D.O1 8 : D.O2 9 : D.O1.2 10 : LOCK	R
412	Reserve	Reserve	R
413	C1_SP1	Set point 1	R
414	C1_SP2	Set point 2	R
415	C1_Profile	Profile number	R
416	C1_Segment	Segment number	R
417	C1_Cycle	Cycle remaining for the current loop	R
418	C1_Run	Profile running	R
419	C1_Hold	Profile held	R
420	C1_Up	Running ramp up segment	R
421	C1_Down	Running ramp down segment	R
422	C1_Unit	Current input unit	R
423	C1_ProfileERROR	Profile error 0 : Normal 1 : Holdback timeout	R
424	C2_PV	Current process value	R
425	C2_SV	Current set point Value	R
426	C2_PVMD	PV mode selection ¹ 0 : PV1 1 : PV2 2 : PV1 - 2 3 : PV2 - 1	R
427	C2_IN1U	IN1 unit selection ² 0 : °C 1 : °F 2 : PU	R
428	C2_IN2U	IN2 unit selection ³ 0 : °C 1 : °F 2 : PU	R
429	C2_MV1	Current output 1 value	R
430	C2_MV2	Current output 2 value	R
431	C2_ALM	Contains conditional code of parameters' resolution and current alarm status ⁴	R
432	C2_ERROR	Current error code ⁵	R

Modbus Address	Notation	Register Name	Access
433	C2_SPMD	Set point mode selection ⁶ 0 : SP1.2 1 : MIN.R 2 : HR.R 3 : PV1 4 : PV2 5 : PUMP	R
434	C2{EIFN	Event input function ⁷ 0 : None 1 : SP2 2 : PID2 3 : SP.P2 4 : RS.A1 5 : RS.A2 6 : R.A1.2 7 : D.O1 8 : D.O2 9 : D.O1.2 10 : LOCK	R
435	Reserve	Reserve	R
436	C2_SP1	Set point 1	R
437	C2_SP2	Set point 2	R
438	C2_Profile	Profile number	R
439	C2_Segment	Segment number	R
440	C2_Cycle	Cycle remaining for the current loop	R
441	C2_Run	Profile running	R
442	C2_Hold	Profile held	R
443	C2_Up	Running ramp up segment	R
444	C2_Down	Running ramp down segment	R
445	C2_Unit	Current input unit	R
446	C2_ProfileERROR	Profile error 0 : Normal 1 : Holdback timeout	R
447	C3_PV	Current process value	R
448	C3_SV	Current set point Value	R
449	C3_PVMD	PV mode selection ¹ 0 : PV1 1 : PV2 2 : PV1 - 2 3 : PV2 - 1	R
450	C3_IN1U	IN1 unit selection ² 0 : °C 1 : °F 2 : PU	R
451	C3_IN2U	IN2 unit selection ³ 0 : °C 1 : °F 2 : PU	R
452	C3_MV1	Current output 1 value	R
453	C3_MV2	Current output 2 value	R
454	C3_ALM	Contains conditional code of parameters' resolution and current alarm status ⁴	R
455	C3_ERROR	Current error code ⁵	R

Modbus Address	Notation	Register Name	Access
456	C3_SPMD	Set point mode selection ⁶ 0 : SP1.2 1 : MIN.R 2 : HR.R 3 : PV1 4 : PV2 5 : PUMP	R
457	C3{EIFN	Event input function ⁷ 0 : None 1 : SP2 2 : PID2 3 : SP.P2 4 : RS.A1 5 : RS.A2 6 : R.A1.2 7 : D.O1 8 : D.O2 9 : D.O1.2 10 : LOCK	R
458	Reserve	Reserve	R
459	C3_SP1	Set point 1	R
460	C3_SP2	Set point 2	R
461	C3_Profile	Profile number	R
462	C3_Segment	Segment number	R
463	C3_Cycle	Cycle remaining for the current loop	R
464	C3_Run	Profile running	R
465	C3_Hold	Profile held	R
466	C3_Up	Running ramp up segment	R
467	C3_Down	Running ramp down segment	R
468	C3_Unit	Current input unit	R
469	C3_ProfileERROR	Profile error 0 : Normal 1 : Holdback timeout	R
470	C4_PV	Current process value	R
471	C4_SV	Current set point Value	R
472	C4_PVMD	PV mode selection ¹ 0 : PV1 1 : PV2 2 : PV1 - 2 3 : PV2 - 1	R
473	C4_IN1U	IN1 unit selection ² 0 : °C 1 : °F 2 : PU	R
474	C4_IN2U	IN2 unit selection ³ 0 : °C 1 : °F 2 : PU	R
475	C4_MV1	Current output 1 value	R
476	C4_MV2	Current output 2 value	R
477	C4_ALM	Contains conditional code of parameters' resolution and current alarm status ⁴	R
478	C4_ERROR	Current error code ⁵	R

Modbus Address	Notation	Register Name	Access
479	C4_SPMD	Set point mode selection ⁶ 0 : SP1.2 1 : MIN.R 2 : HR.R 3 : PV1 4 : PV2 5 : PUMP	R
480	C4{EIFN	Event input function ⁷ 0 : None 1 : SP2 2 : PID2 3 : SP.P2 4 : RS.A1 5 : RS.A2 6 : R.A1.2 7 : D.O1 8 : D.O2 9 : D.O1.2 10 : LOCK	R
481	Reserve	Reserve	R
482	C4_SP1	Set point 1	R
483	C4_SP2	Set point 2	R
484	C4_Profile	Profile number	R
485	C4_Segment	Segment number	R
486	C4_Cycle	Cycle remaining for the current loop	R
487	C4_Run	Profile running	R
488	C4_Hold	Profile held	R
489	C4_Up	Running ramp up segment	R
490	C4_Down	Running ramp down segment	R
491	C4_Unit	Current input unit	R
492	C4_ProfileERROR	Profile error 0 : Normal 1 : Holdback timeout	R
493	C5_PV	Current process value	R
494	C5_SV	Current set point Value	R
495	C5_PVMD	PV mode selection ¹ 0 : PV1 1 : PV2 2 : PV1 - 2 3 : PV2 - 1	R
496	C5_IN1U	IN1 unit selection ² 0 : °C 1 : °F 2 : PU	R
497	C5_IN2U	IN2 unit selection ³ 0 : °C 1 : °F 2 : PU	R
498	C5_MV1	Current output 1 value	R
499	C5_MV2	Current output 2 value	R
500	C5_ALM	Contains conditional code of parameters' resolution and current alarm status ⁴	R
501	C5_ERROR	Current error code ⁵	R

Modbus Address	Notation	Register Name	Access
502	C5_SPMD	Set point mode selection ⁶ 0 : SP1.2 1 : MIN.R 2 : HR.R 3 : PV1 4 : PV2 5 : PUMP	R
503	C5{EIFN	Event input function ⁷ 0 : None 1 : SP2 2 : PID2 3 : SP.P2 4 : RS.A1 5 : RS.A2 6 : R.A1.2 7 : D.O1 8 : D.O2 9 : D.O1.2 10 : LOCK	R
504	Reserve	Reserve	R
505	C5_SP1	Set point 1	R
506	C5_SP2	Set point 2	R
507	C5_Profile	Profile number	R
508	C5_Segment	Segment number	R
509	C5_Cycle	Cycle remaining for the current loop	R
510	C5_Run	Profile running	R
511	C5_Hold	Profile held	R
512	C5_Up	Running ramp up segment	R
513	C5_Down	Running ramp down segment	R
514	C5_Unit	Current input unit	R
515	C5_ProfileERROR	Profile error 0 : Normal 1 : Holdback timeout	R
516	C6_PV	Current process value	R
517	C6_SV	Current set point Value	R
518	C6_PVMD	PV mode selection ¹ 0 : PV1 1 : PV2 2 : PV1 - 2 3 : PV2 - 1	R
519	C6_IN1U	IN1 unit selection ² 0 : °C 1 : °F 2 : PU	R
520	C6_IN2U	IN2 unit selection ³ 0 : °C 1 : °F 2 : PU	R
521	C6_MV1	Current output 1 value	R
522	C6_MV2	Current output 2 value	R
523	C6_ALM	Contains conditional code of parameters' resolution and current alarm status ⁴	R
524	C6_ERROR	Current error code ⁵	R

Modbus Address	Notation	Register Name	Access
525	C6_SPMD	Set point mode selection ⁶ 0 : SP1.2 1 : MIN.R 2 : HR.R 3 : PV1 4 : PV2 5 : PUMP	R
526	C6{EIFN	Event input function ⁷ 0 : None 1 : SP2 2 : PID2 3 : SP.P2 4 : RS.A1 5 : RS.A2 6 : R.A1.2 7 : D.O1 8 : D.O2 9 : D.O1.2 10 : LOCK	R
527	Reserve	Reserve	R
528	C6_SP1	Set point 1	R
529	C6_SP2	Set point 2	R
530	C6_Profile	Profile number	R
531	C6_Segment	Segment number	R
532	C6_Cycle	Cycle remaining for the current loop	R
533	C6_Run	Profile running	R
534	C6_Hold	Profile held	R
535	C6_Up	Running ramp up segment	R
536	C6_Down	Running ramp down segment	R
537	C6_Unit	Current input unit	R
538	C6_ProfileERROR	Profile error 0 : Normal 1 : Holdback timeout	R
539	C7_PV	Current process value	R
540	C7_SV	Current set point Value	R
541	C7_PVMD	PV mode selection1 0 : PV1 1 : PV2 2 : PV1 - 2 3 : PV2 - 1	R
542	C7_IN1U	IN1 unit selection2 0 : °C 1 : °F 2 : PU	R
543	C7_IN2U	IN2 unit selection3 0 : °C 1 : °F 2 : PU	R
544	C7_MV1	Current output 1 value	R
545	C7_MV2	Current output 2 value	R
546	C7_ALM	Contains conditional code of parameters' resolution and current alarm status ⁴	R
547	C7_ERROR	Current error code ⁵	R

Modbus Address	Notation	Register Name	Access
548	C7_SPMD	Set point mode selection6 0 : SP1.2 1 : MIN.R 2 : HR.R 3 : PV1 4 : PV2 5 : PUMP	R
549	C7_EIFN	Event input function7 0 : None 1 : SP2 2 : PID2 3 : SP.P2 4 : RS.A1 5 : RS.A2 6 : R.A1.2 7 : D.O1 8 : D.O2 9 : D.O1.2 10 : LOCK	R
550	Reserve	Reserve	R
551	C7_SP1	Set point 1	R
552	C7_SP2	Set point 2	R
553	C7_Profile	Profile number	R
554	C7_Segment	Segment number	R
555	C7_Cycle	Cycle remainingfor the currentloop	R
556	C7_Run	Profile running	R
557	C7_Hold	Profile held	R
558	C7_Up	Running ramp up segment	R
559	C7_Down	Running ramp down segment	R
560	C7_Unit	Current input unit	R
561	C7_ProfileERROR	Profile error 0 : Normal 1 : Holdback timeout	R
562	C8_PV	Current process value	R
563	C8_SV	Current set point Value	R
564	C8_PVMD	PV mode selection1 0 : PV1 1 : PV2 2 : PV1 - 2 3 : PV2 - 1	R
565	C8_IN1U	IN1 unit selection2 0 : °C 1 : °F 2 : PU	R
566	C8_IN2U	IN2 unit selection3 0 : °C 1 : °F 2 : PU	R
567	C8_MV1	Current output 1 value	R
568	C8_MV2	Current output 2 value	R
569	C8_ALM	Contains conditional code of parameters' resolution and current alarm status4	R
570	C8_ERROR	Current error code5	R

Modbus Address	Notation	Register Name	Access
571	C8_SPMD	Set point mode selection6 0 : SP1.2 1 : MIN.R 2 : HR.R 3 : PV1 4 : PV2 5 : PUMP	R
572	C8{EIFN	Event input function7 0 : None 1 : SP2 2 : PID2 3 : SP.P2 4 : RS.A1 5 : RS.A2 6 : R.A1.2 7 : D.O1 8 : D.O2 9 : D.O1.2 10 : LOCK	R
573	Reserve	Reserve	R
574	C8_SP1	Set point 1	R
575	C8_SP2	Set point 2	R
576	C8_Profile	Profile number	R
577	C8_Segment	Segment number	R
578	C8_Cycle	Cycle remainingfor the currentloop	R
579	C8_Run	Profile running	R
580	C8_Hold	Profile held	R
581	C8_Up	Running ramp up segment	R
582	C8_Down	Running ramp down segment	R
583	C8_Unit	Current input unit	R
584	C8_ProfileERROR	Profile error 0 : Normal 1 : Holdback timeout	R

Note 1: PVMD

Parameter Value	Display Symbol	Description
0	PV1	Use PV1 as process value
1	PV2	Use PV2 as process value
2	P1 - 2	Use PV1 - PV2 (difference) as process value
3	P2 - 1	Use PV2 - PV1 (difference) as process value

Note 2, 3: IN1/IN2 unit

Parameter Value	Display Symbol	Description
0	°C	Degree C unit
1	°F	Degree F unit
2	PU	Process unit

Note 4: ALM

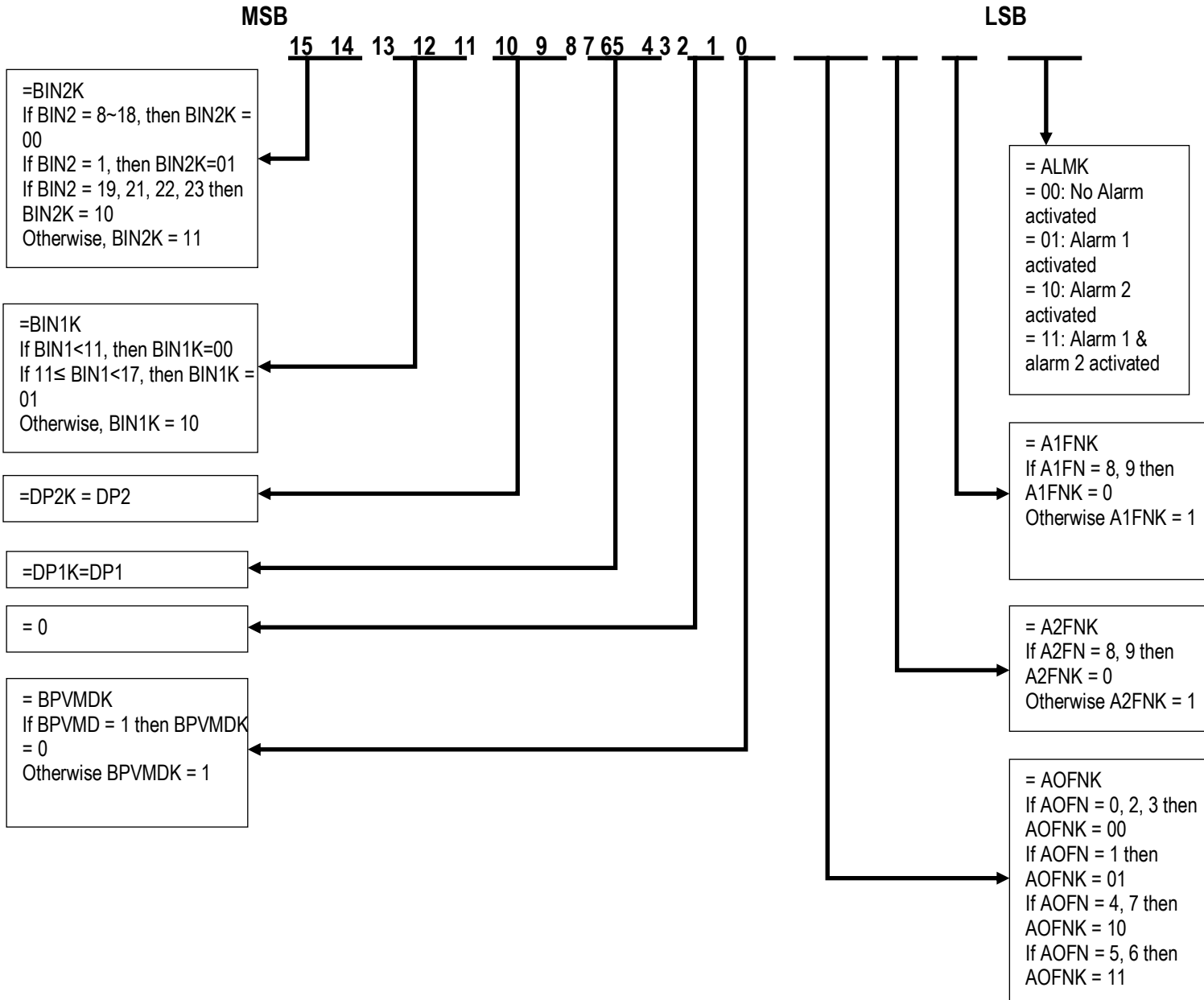

Note 5: Error Code

Error Code	Error Description
1	Illegal setup values used: PV1 is used for both PVMD and SPMD that is meaningless for control
2	Illegal setup values used: PV2 is used for both PVMD and SPMD that is meaningless for control
3	Illegal setup values used: P1-2 or P2-1 is used for PVMD while PV1 or PV2 is used for SPMD. Dependent values are used for PV and SV will produce incorrect result of control
4	Illegal setup values used: COOL is used for OUT2, but DIRT (cooling action) is already used for OUT1 or PID mode is not used for OUT1 (that is PB1 or PB2 = 0, and T11 or T12 = 0)
5	Illegal setup values used: unequal IN1U and IN2U or unequal DP1 and DP2 while P1-2 or P2-1 is used for PVMD or, PV1 or PV2 is used for SPMD or, P1.2.H, P1.2.L, D1.2.H or D1.2.L are used for A1FN or A2FN
6	Illegal setup values used: OUT2 select = AL2 but A2FN select NONE
7	Illegal setup values used: Dwell timer (TIMR) is selected for both A1FN and A2FN
17	Computing error: Illegal floating point data
18	Computing error: Arithmetic result overflow or underflow
19	Computing error: divided by zero
20	Computing error: Illegal BCD data entry
21	Timing error: A to D conversion data error due to overrun
26	Fail to perform auto-tuning function

Error Code	Error Description
27	Incorrect calibration procedure or tolerance of analog component too big to meet specified accuracy
32	Cold junction compensation device(s) malfunction
34	Input 2 (IN2) signal too low
35	Input 2 (IN2) signal too high
36	Input 1 (IN1) signal too low
37	Input 1 (IN1) signal too high
38	Input 2 (IN2) sensor break, or input 2 current below 1 mA if 4-20 mA is selected, or input 2 voltage below 0.25V if 1 - 5V is selected
39	Input 1 (IN1) sensor break, or input 1 current below 1 mA if 4-20 mA is selected, or input 1 voltage below 0.25V if 1 - 5V is selected
40	A to D converter or related component(s) malfunction

Note 6: SPMD

Parameter Value	Display Symbol	Description
0	SP1.2	Use SP1 or SP2 (depends on EIFN) as set point
1	MIN.R	Use minute ramp rate as set point
2	HR.R	Use hour ramp rate as set point
3	PV1	Use IN1 process value as set point
4	PV2	Use IN2 process value as set point
5	PUMP	Selected for pump control

Note 7: EIFN

Parameter Value	Display Symbol	Description
0	NONE	Event input no function
1	SP2	SP2 activated to replace SP1
2	PID2	PB2, TI2, TD2 activated to replace PB1, TI1, TD1
3	SP.P2	SP2, PB2, TI2, TD2 activated to replace SP1, PB1, TI1, TD1
4	RS.A1	Reset alarm 1 output
5	RS.A2	Reset alarm 2 output
6	R.A1.2	Reset alarm 1 & alarm 2
7	D.O1	Disable Output 1
8	D.O2	Disable Output 2
9	D.O1.2	Disable Output 1 & Output 2
10	LOCK	Lock all parameters

8.1.1.6 PID Process Control Module Data (Float Type)

Modbus Address	Notation	Register Name	Access
1601	C1_PV	Current process value	R
1603	C1_SV	Current set point Value	R
1605	C1_PVMD	PV mode selection ¹ 0 : PV1 1 : PV2 2 : PV1 - 2 3 : PV2 - 1	R
1607	C1_IN1U	IN1 unit selection ² 0 : °C 1 : °F 2 : PU	R
1609	C1_IN2U	IN2 unit selection ³ 0 : °C 1 : °F 2 : PU	R
1611	C1_MV1	Current output 1 value	R
1613	C1_MV2	Current output 2 value	R
1615	C1_ALM	Contains conditional code of parameters' resolution and current alarm status ⁴	R

Modbus Address	Notation	Register Name	Access
1617	C1_ERROR	Current error code ²	R
1619	C1_SPMD	Set point mode selection ⁶ 0 : SP1.2 1 : MIN.R 2 : HR.R 3 : PV1 4 : PV2 5 : PUMP	R
1621	C1_EIFN	Event input function ⁷ 0 : None 1 : SP2 2 : PID2 3 : SP.P2 4 : RS.A1 5 : RS.A2 6 : R.A1.2 7 : D.O1 8 : D.O2 9 : D.O1.2 10 : LOCK	R
1623	Reserve	Reserve	R
1625	C1_SP1	Set point 1	R
1627	C1_SP2	Set point 2	R
1629	C1_Profile	Profile number	R
1631	C1_Segment	Segment number	R
1633	C1_Cycle	Cycle remaining for the current loop	R
1635	C1_Run	Profile running	R
1637	C1_Hold	Profile held	R
1639	C1_Up	Running ramp up segment	R
1641	C1_Down	Running ramp down segment	R
1643	C1_Unit	Current input unit	R
1645	C1_ProfileERROR	Profile error 0 : Normal 1 : Holdback timeout	R
1647	C2_PV	Current process value	R
1649	C2_SV	Current set point Value	R
1651	C2_PVMD	PV mode selection ¹ 0 : PV1 1 : PV2 2 : PV1 - 2 3 : PV2 - 1	R
1653	C2_IN1U	IN1 unit selection ² 0 : °C 1 : °F 2 : PU	R
1655	C2_IN2U	IN2 unit selection ³ 0 : °C 1 : °F 2 : PU	R
1657	C2_MV1	Current output 1 value	R
1659	C2_MV2	Current output 2 value	R
1661	C2_ALM	Contains conditional code of parameters' resolution and current alarm status ⁴	R
1663	C2_ERROR	Current error code ²	R

Modbus Address	Notation	Register Name	Access
1665	C2_SPMD	Set point mode selection ⁶ 0 : SP1.2 1 : MIN.R 2 : HR.R 3 : PV1 4 : PV2 5 : PUMP	R
1667	C2_EIFN	Event input function ⁷ 0 : None 1 : SP2 2 : PID2 3 : SP.P2 4 : RS.A1 5 : RS.A2 6 : R.A1.2 7 : D.O1 8 : D.O2 9 : D.O1.2 10 : LOCK	R
1669	Reserve	Reserve	R
1671	C2_SP1	Set point 1	R
1673	C2_SP2	Set point 2	R
1675	C2_Profile	Profile number	R
1677	C2_Segment	Segment number	R
1679	C2_Cycle	Cycle remaining for the current loop	R
1681	C2_Run	Profile running	R
1683	C2_Hold	Profile held	R
1685	C2_Up	Running ramp up segment	R
1687	C2_Down	Running ramp down segment	R
1689	C2_Unit	Current input unit	R
1691	C2_ProfileERROR	Profile error 0 : Normal 1 : Holdback timeout	R
1693	C3_PV	Current process value	R
1695	C3_SV	Current set point Value	R
1697	C3_PVMD	PV mode selection ¹ 0 : PV1 1 : PV2 2 : PV1 - 2 3 : PV2 - 1	R
1699	C3_IN1U	IN1 unit selection ² 0 : °C 1 : °F 2 : PU	R
1701	C3_IN2U	IN2 unit selection ³ 0 : °C 1 : °F 2 : PU	R
1703	C3_MV1	Current output 1 value	R
1705	C3_MV2	Current output 2 value	R
1707	C3_ALM	Contains conditional code of parameters' resolution and current alarm status ⁴	R
1709	C3_ERROR	Current error code ⁵	R

Modbus Address	Notation	Register Name	Access
1711	C3_SPMD	Set point mode selection ⁶ 0 : SP1.2 1 : MIN.R 2 : HR.R 3 : PV1 4 : PV2 5 : PUMP	R
1713	C3_EIFN	Event input function ⁷ 0 : None 1 : SP2 2 : PID2 3 : SP.P2 4 : RS.A1 5 : RS.A2 6 : R.A1.2 7 : D.O1 8 : D.O2 9 : D.O1.2 10 : LOCK	R
1715	Reserve	Reserve	R
1717	C3_SP1	Set point 1	R
1719	C3_SP2	Set point 2	R
1721	C3_Profile	Profile number	R
1723	C3_Segment	Segment number	R
1725	C3_Cycle	Cycle remaining for the current loop	R
1727	C3_Run	Profile running	R
1729	C3_Hold	Profile held	R
1731	C3_Up	Running ramp up segment	R
1733	C3_Down	Running ramp down segment	R
1735	C3_Unit	Current input unit	R
1737	C3_ProfileERROR	Profile error 0 : Normal 1 : Holdback timeout	R
1739	C4_PV	Current process value	R
1741	C4_SV	Current set point Value	R
1743	C4_PVMD	PV mode selection ¹ 0 : PV1 1 : PV2 2 : PV1 - 2 3 : PV2 - 1	R
1745	C4_IN1U	IN1 unit selection ² 0 : °C 1 : °F 2 : PU	R
1747	C4_IN2U	IN2 unit selection ³ 0 : °C 1 : °F 2 : PU	R
1749	C4_MV1	Current output 1 value	R
1751	C4_MV2	Current output 2 value	R
1753	C4_ALM	Contains conditional code of parameters' resolution and current alarm status ⁴	R
1755	C4_ERROR	Current error code ⁵	R

Modbus Address	Notation	Register Name	Access
1757	C4_SPMD	Set point mode selection ⁶ 0 : SP1.2 1 : MIN.R 2 : HR.R 3 : PV1 4 : PV2 5 : PUMP	R
1759	C4{EIFN	Event input function ⁷ 0 : None 1 : SP2 2 : PID2 3 : SP.P2 4 : RS.A1 5 : RS.A2 6 : R.A1.2 7 : D.O1 8 : D.O2 9 : D.O1.2 10 : LOCK	R
1761	Reserve	Reserve	R
1763	C4_SP1	Set point 1	R
1765	C4_SP2	Set point 2	R
1767	C4_Profile	Profile number	R
1769	C4_Segment	Segment number	R
1771	C4_Cycle	Cycle remaining for the current loop	R
1773	C4_Run	Profile running	R
1775	C4_Hold	Profile held	R
1777	C4_Up	Running ramp up segment	R
1779	C4_Down	Running ramp down segment	R
1781	C4_Unit	Current input unit	R
1783	C4_ProfileERROR	Profile error 0 : Normal 1 : Holdback timeout	R
1785	C5_PV	Current process value	R
1787	C5_SV	Current set point Value	R
1789	C5_PVMD	PV mode selection ¹ 0 : PV1 1 : PV2 2 : PV1 - 2 3 : PV2 - 1	R
1791	C5_IN1U	IN1 unit selection ² 0 : °C 1 : °F 2 : PU	R
1793	C5_IN2U	IN2 unit selection ³ 0 : °C 1 : °F 2 : PU	R
1795	C5_MV1	Current output 1 value	R
1797	C5_MV2	Current output 2 value	R
1799	C5_ALM	Contains conditional code of parameters' resolution and current alarm status ⁴	R
1801	C5_ERROR	Current error code ⁵	R

Modbus Address	Notation	Register Name	Access
1803	C5_SPMD	Set point mode selection ⁶ 0 : SP1.2 1 : MIN.R 2 : HR.R 3 : PV1 4 : PV2 5 : PUMP	R
1805	C5{EIFN	Event input function ⁷ 0 : None 1 : SP2 2 : PID2 3 : SP.P2 4 : RS.A1 5 : RS.A2 6 : R.A1.2 7 : D.O1 8 : D.O2 9 : D.O1.2 10 : LOCK	R
1807	Reserve	Reserve	R
1809	C5_SP1	Set point 1	R
1811	C5_SP2	Set point 2	R
1813	C5_Profile	Profile number	R
1815	C5_Segment	Segment number	R
1817	C5_Cycle	Cycle remaining for the current loop	R
1819	C5_Run	Profile running	R
1821	C5_Hold	Profile held	R
1823	C5_Up	Running ramp up segment	R
1825	C5_Down	Running ramp down segment	R
1827	C5_Unit	Current input unit	R
1829	C5_ProfileERROR	Profile error 0 : Normal 1 : Holdback timeout	R
1831	C6_PV	Current process value	R
1833	C6_SV	Current set point Value	R
1835	C6_PVMD	PV mode selection ¹ 0 : PV1 1 : PV2 2 : PV1 - 2 3 : PV2 - 1	R
1837	C6_IN1U	IN1 unit selection ² 0 : °C 1 : °F 2 : PU	R
1839	C6_IN2U	IN2 unit selection ³ 0 : °C 1 : °F 2 : PU	R
1841	C6_MV1	Current output 1 value	R
1843	C6_MV2	Current output 2 value	R
1845	C6_ALM	Contains conditional code of parameters' resolution and current alarm status ⁴	R
1847	C6_ERROR	Current error code ⁵	R

Modbus Address	Notation	Register Name	Access
1849	C6_SPMD	Set point mode selection ⁶ 0 : SP1.2 1 : MIN.R 2 : HR.R 3 : PV1 4 : PV2 5 : PUMP	R
1851	C6{EIFN	Event input function ⁷ 0 : None 1 : SP2 2 : PID2 3 : SP.P2 4 : RS.A1 5 : RS.A2 6 : R.A1.2 7 : D.O1 8 : D.O2 9 : D.O1.2 10 : LOCK	R
1853	Reserve	Reserve	R
1855	C6_SP1	Set point 1	R
1857	C6_SP2	Set point 2	R
1859	C6_Profile	Profile number	R
1861	C6_Segment	Segment number	R
1863	C6_Cycle	Cycle remaining for the current loop	R
1865	C6_Run	Profile running	R
1867	C6_Hold	Profile held	R
1869	C6_Up	Running ramp up segment	R
1871	C6_Down	Running ramp down segment	R
1873	C6_Unit	Current input unit	R
1875	C6_ProfileERROR	Profile error 0 : Normal 1 : Holdback timeout	R
1877	C7_PV	Current process value	R
1879	C7_SV	Current set point Value	R
1881	C7_PVMD	PV mode selection ¹ 0 : PV1 1 : PV2 2 : PV1 - 2 3 : PV2 - 1	R
1883	C7_IN1U	IN1 unit selection ² 0 : °C 1 : °F 2 : PU	R
1885	C7_IN2U	IN2 unit selection ³ 0 : °C 1 : °F 2 : PU	R
1887	C7_MV1	Current output 1 value	R
1889	C7_MV2	Current output 2 value	R
1891	C7_ALM	Contains conditional code of parameters' resolution and current alarm status ⁴	R
1893	C7_ERROR	Current error code ⁵	R

Modbus Address	Notation	Register Name	Access
1895	C7_SPMD	Set point mode selection6 0 : SP1.2 1 : MIN.R 2 : HR.R 3 : PV1 4 : PV2 5 : PUMP	R
1897	C7_EIFN	Event input function7 0 : None 1 : SP2 2 : PID2 3 : SP.P2 4 : RS.A1 5 : RS.A2 6 : R.A1.2 7 : D.O1 8 : D.O2 9 : D.O1.2 10 : LOCK	R
1899	Reserve	Reserve	R
1901	C7_SP1	Set point 1	R
1903	C7_SP2	Set point 2	R
1905	C7_Profile	Profile number	R
1907	C7_Segment	Segment number	R
1909	C7_Cycle	Cycle remainingfor the currentloop	R
1911	C7_Run	Profile running	R
1913	C7_Hold	Profile held	R
1915	C7_Up	Running ramp up segment	R
1917	C7_Down	Running ramp down segment	R
1919	C7_Unit	Current input unit	R
1921	C7_ProfileERROR	Profile error 0 : Normal 1 : Holdback timeout	R
1923	C8_PV	Current process value	R
1925	C8_SV	Current set point Value	R
1927	C8_PVMD	PV mode selection1 0 : PV1 1 : PV2 2 : PV1 - 2 3 : PV2 - 1	R
1929	C8_IN1U	IN1 unit selection2 0 : °C 1 : °F 2 : PU	R
1931	C8_IN2U	IN2 unit selection3 0 : °C 1 : °F 2 : PU	R
1933	C8_MV1	Current output 1 value	R
1935	C8_MV2	Current output 2 value	R
1937	C8_ALM	Contains conditional code of parameters' resolution and current alarm status4	R
1939	C8_ERROR	Current error code5	R

Modbus Address	Notation	Register Name	Access
1941	C8_SPMD	Set point mode selection6 0 : SP1.2 1 : MIN.R 2 : HR.R 3 : PV1 4 : PV2 5 : PUMP	R
1943	C8{EIFN	Event input function7 0 : None 1 : SP2 2 : PID2 3 : SP.P2 4 : RS.A1 5 : RS.A2 6 : R.A1.2 7 : D.O1 8 : D.O2 9 : D.O1.2 10 : LOCK	R
1945	Reserve	Reserve	R
1947	C8_SP1	Set point 1	R
1949	C8_SP2	Set point 2	R
1951	C8_Profile	Profile number	R
1953	C8_Segment	Segment number	R
1955	C8_Cycle	Cycle remainingfor the currentloop	R
1957	C8_Run	Profile running	R
1959	C8_Hold	Profile held	R
1961	C8_Up	Running ramp up segment	R
1963	C8_Down	Running ramp down segment	R
1965	C8_Unit	Current input unit	R
1967	C8_ProfileERROR	Profile error 0 : Normal 1 : Holdback timeout	R

8.1.1.7 System Information(Integer Type)

Modbus Address	Register Name	Access
901	Percentage free of internal memory	R
902	Percentage free of external memory	R

8.1.1.8 System Information (Float Type)

Modbus Address	Register Name	Access
2901	Percentage free of internal memory	R
2903	Percentage free of external memory	R

8.1.2 Holding Register (4xxxxx) Parameter Table for Modbus RTU Slave / TCP Server

8.1.2.1 External Channels 2 Bytes Data(Integer Type)

Modbus Address	Notation	Register Name	Access
1	Ext1	Measured data on External 1	R/W
2	Ext2	Measured data on External 2	R/W
3	Ext3	Measured data on External 3	R/W
4	Ext4	Measured data on External 4	R/W
5	Ext5	Measured data on External 5	R/W
6	Ext6	Measured data on External 6	R/W
7	Ext7	Measured data on External 7	R/W
8	Ext8	Measured data on External 8	R/W
9	Ext9	Measured data on External 9	R/W
10	Ext10	Measured data on External 10	R/W
11	Ext11	Measured data on External 11	R/W
12	Ext12	Measured data on External 12	R/W
13	Ext13	Measured data on External 13	R/W
14	Ext14	Measured data on External 14	R/W
15	Ext15	Measured data on External 15	R/W
16	Ext16	Measured data on External 16	R/W
17	Ext17	Measured data on External 17	R/W
18	Ext18	Measured data on External 18	R/W
19	Ext19	Measured data on External 19	R/W
20	Ext20	Measured data on External 20	R/W
21	Ext21	Measured data on External 21	R/W
22	Ext22	Measured data on External 22	R/W
23	Ext23	Measured data on External 23	R/W
24	Ext24	Measured data on External 24	R/W
25	Ext25	Measured data on External 25	R/W
26	Ext26	Measured data on External 26	R/W
27	Ext27	Measured data on External 27	R/W
28	Ext28	Measured data on External 28	R/W
29	Ext29	Measured data on External 29	R/W
30	Ext30	Measured data on External 30	R/W
31	Ext31	Measured data on External 31	R/W
32	Ext32	Measured data on External 32	R/W
33	Ext33	Measured data on External 33	R/W
34	Ext34	Measured data on External 34	R/W
35	Ext35	Measured data on External 35	R/W
36	Ext36	Measured data on External 36	R/W
37	Ext37	Measured data on External 37	R/W
38	Ext38	Measured data on External 38	R/W
39	Ext39	Measured data on External 39	R/W
40	Ext40	Measured data on External 40	R/W
41	Ext41	Measured data on External 41	R/W
42	Ext42	Measured data on External 42	R/W
43	Ext43	Measured data on External 43	R/W
44	Ext44	Measured data on External 44	R/W
45	Ext45	Measured data on External 45	R/W
46	Ext46	Measured data on External 46	R/W
47	Ext47	Measured data on External 47	R/W
48	Ext48	Measured data on External 48	R/W
49	Ext49	Measured data on External 49	R/W
50	Ext50	Measured data on External 50	R/W
51	Ext51	Measured data on External 51	R/W
52	Ext52	Measured data on External 52	R/W

Modbus Address	Notation	Register Name	Access
53	Ext53	Measured data on External 53	R/W
54	Ext54	Measured data on External 54	R/W
55	Ext55	Measured data on External 55	R/W
56	Ext56	Measured data on External 56	R/W
57	Ext57	Measured data on External 57	R/W
58	Ext58	Measured data on External 58	R/W
59	Ext59	Measured data on External 59	R/W
60	Ext60	Measured data on External 60	R/W
61	Ext61	Measured data on External 61	R/W
62	Ext62	Measured data on External 62	R/W
63	Ext63	Measured data on External 63	R/W
64	Ext64	Measured data on External 64	R/W
65	Ext65	Measured data on External 65	R/W
66	Ext66	Measured data on External 66	R/W
67	Ext67	Measured data on External 67	R/W
68	Ext68	Measured data on External 68	R/W
69	Ext69	Measured data on External 69	R/W
70	Ext70	Measured data on External 70	R/W
71	Ext71	Measured data on External 71	R/W
72	Ext72	Measured data on External 72	R/W
73	Ext73	Measured data on External 73	R/W
74	Ext74	Measured data on External 74	R/W
75	Ext75	Measured data on External 75	R/W
76	Ext76	Measured data on External 76	R/W
77	Ext77	Measured data on External 77	R/W
78	Ext78	Measured data on External 78	R/W
79	Ext79	Measured data on External 79	R/W
80	Ext80	Measured data on External 80	R/W
81	Ext81	Measured data on External 81	R/W
82	Ext82	Measured data on External 82	R/W
83	Ext83	Measured data on External 83	R/W
84	Ext84	Measured data on External 84	R/W
85	Ext85	Measured data on External 85	R/W
86	Ext86	Measured data on External 86	R/W
87	Ext87	Measured data on External 87	R/W
88	Ext88	Measured data on External 88	R/W
89	Ext89	Measured data on External 89	R/W
90	Ext90	Measured data on External 90	R/W
91	Ext91	Measured data on External 91	R/W
92	Ext92	Measured data on External 92	R/W
93	Ext93	Measured data on External 93	R/W
94	Ext94	Measured data on External 94	R/W
95	Ext95	Measured data on External 95	R/W
96	Ext96	Measured data on External 96	R/W

Note: If the register value is 65534, then there is a communication error.

8.1.2.2 External Channels 4 Bytes Data(Integer Type)

Modbus Address	Notation	Register Name	Access
201	Ext1	The high word of measured data is on External 1	R/W
202	Ext1	The low word of measured data is on External 1	R/W
203	Ext2	The high word of measured data is on External 2	R/W
204	Ext2	The low word of measured data is on External 2	R/W
205	Ext3	The high word of measured data is on External 3	R/W
206	Ext3	The low word of measured data is on External 3	R/W
207	Ext4	The high word of measured data is on External 4	R/W
208	Ext4	The low word of measured data is on External 4	R/W
209	Ext5	The high word of measured data is on External 5	R/W
210	Ext5	The low word of measured data is on External 5	R/W
211	Ext6	The high word of measured data is on External 6	R/W
212	Ext6	The low word of measured data is on External 6	R/W
213	Ext7	The high word of measured data is on External 7	R/W
214	Ext7	The low word of measured data is on External 7	R/W
215	Ext8	The high word of measured data is on External 8	R/W
216	Ext8	The low word of measured data is on External 8	R/W
217	Ext9	The high word of measured data is on External 9	R/W
218	Ext9	The low word of measured data is on External 9	R/W
219	Ext10	The high word of measured data is on External 10	R/W
220	Ext10	The low word of measured data is on External 10	R/W
221	Ext11	The high word of measured data is on External 11	R/W
222	Ext11	The low word of measured data is on External 11	R/W
223	Ext12	The high word of measured data is on External 12	R/W
224	Ext12	The low word of measured data is on External 12	R/W
225	Ext13	The high word of measured data is on External 13	R/W
226	Ext13	The low word of measured data is on External 13	R/W
227	Ext14	The high word of measured data is on External 14	R/W
228	Ext14	The low word of measured data is on External 14	R/W
229	Ext15	The high word of measured data is on External 15	R/W
230	Ext15	The low word of measured data is on External 15	R/W
231	Ext16	The high word of measured data is on External 16	R/W
232	Ext16	The low word of measured data is on External 16	R/W
233	Ext17	The high word of measured data is on External 17	R/W
234	Ext17	The low word of measured data is on External 17	R/W
235	Ext18	The high word of measured data is on External 18	R/W
236	Ext18	The low word of measured data is on External 18	R/W
237	Ext19	The high word of measured data is on External 19	R/W
238	Ext19	The low word of measured data is on External 19	R/W
239	Ext20	The high word of measured data is on External 20	R/W
240	Ext20	The low word of measured data is on External 20	R/W
241	Ext21	The high word of measured data is on External 21	R/W
242	Ext21	The low word of measured data is on External 21	R/W
243	Ext22	The high word of measured data is on External 22	R/W
244	Ext22	The low word of measured data is on External 22	R/W
245	Ext23	The high word of measured data is on External 23	R/W
246	Ext23	The low word of measured data is on External 23	R/W
247	Ext24	The high word of measured data is on External 24	R/W
248	Ext24	The low word of measured data is on External 24	R/W
249	Ext25	The high word of measured data is on External 25	R/W
250	Ext25	The low word of measured data is on External 25	R/W
251	Ext26	The high word of measured data is on External 26	R/W
252	Ext26	The low word of measured data is on External 26	R/W
253	Ext27	The high word of measured data is on External 27	R/W
254	Ext27	The low word of measured data is on External 27	R/W

Modbus Address	Notation	Register Name	Access
255	Ext28	The high word of measured data is on External 28	R/W
256	Ext28	The low word of measured data is on External 28	R/W
257	Ext29	The high word of measured data is on External 29	R/W
258	Ext29	The low word of measured data is on External 29	R/W
259	Ext30	The high word of measured data is on External 30	R/W
260	Ext30	The low word of measured data is on External 30	R/W
261	Ext31	The high word of measured data is on External 31	R/W
262	Ext31	The low word of measured data is on External 31	R/W
263	Ext32	The high word of measured data is on External 32	R/W
264	Ext32	The low word of measured data is on External 32	R/W
265	Ext33	The high word of measured data is on External 33	R/W
266	Ext33	The low word of measured data is on External 33	R/W
267	Ext34	The high word of measured data is on External 34	R/W
268	Ext34	The low word of measured data is on External 34	R/W
269	Ext35	The high word of measured data is on External 35	R/W
270	Ext35	The high word of measured data is on External 35	R/W
271	Ext36	The high word of measured data is on External 36	R/W
272	Ext36	The low word of measured data is on External 36	R/W
273	Ext37	The high word of measured data is on External 37	R/W
274	Ext37	The low word of measured data is on External 37	R/W
275	Ext38	The high word of measured data is on External 38	R/W
276	Ext38	The low word of measured data is on External 38	R/W
277	Ext39	The high word of measured data is on External 39	R/W
278	Ext39	The low word of measured data is on External 39	R/W
279	Ext40	The high word of measured data is on External 40	R/W
280	Ext40	The low word of measured data is on External 40	R/W
281	Ext41	The high word of measured data is on External 41	R/W
282	Ext41	The low word of measured data is on External 41	R/W
283	Ext42	The high word of measured data is on External 42	R/W
284	Ext42	The low word of measured data is on External 42	R/W
285	Ext43	The high word of measured data is on External 43	R/W
286	Ext43	The low word of measured data is on External 43	R/W
287	Ext44	The high word of measured data is on External 44	R/W
288	Ext44	The low word of measured data is on External 44	R/W
289	Ext45	The high word of measured data is on External 45	R/W
290	Ext45	The low word of measured data is on External 45	R/W
291	Ext46	The high word of measured data is on External 46	R/W
292	Ext46	The low word of measured data is on External 46	R/W
293	Ext47	The high word of measured data is on External 47	R/W
294	Ext47	The low word of measured data is on External 47	R/W
295	Ext48	The high word of measured data is on External 48	R/W
296	Ext48	The low word of measured data is on External 48	R/W
297	Ext49	The high word of measured data is on External 49	R/W
298	Ext49	The low word of measured data is on External 49	R/W
299	Ext50	The high word of measured data is on External 50	R/W
300	Ext50	The low word of measured data is on External 50	R/W
301	Ext51	The high word of measured data is on External 51	R/W
302	Ext51	The low word of measured data is on External 51	R/W
303	Ext52	The high word of measured data is on External 52	R/W
304	Ext52	The low word of measured data is on External 52	R/W
305	Ext53	The high word of measured data is on External 53	R/W
306	Ext53	The low word of measured data is on External 53	R/W
307	Ext54	The high word of measured data is on External 54	R/W
308	Ext54	The low word of measured data is on External 54	R/W
309	Ext55	The high word of measured data is on External 55	R/W
310	Ext55	The low word of measured data is on External 55	R/W

Modbus Address	Notation	Register Name	Access
311	Ext56	The high word of measured data is on External 56	R/W
312	Ext56	The low word of measured data is on External 56	R/W
313	Ext57	The high word of measured data is on External 57	R/W
314	Ext57	The low word of measured data is on External 57	R/W
315	Ext58	The high word of measured data is on External 58	R/W
316	Ext58	The low word of measured data is on External 58	R/W
317	Ext59	The high word of measured data is on External 59	R/W
318	Ext59	The low word of measured data is on External 59	R/W
319	Ext60	The high word of measured data is on External 60	R/W
320	Ext60	The low word of measured data is on External 60	R/W
321	Ext61	The high word of measured data is on External 61	R/W
322	Ext61	The low word of measured data is on External 61	R/W
323	Ext62	The high word of measured data is on External 62	R/W
324	Ext62	The low word of measured data is on External 62	R/W
325	Ext63	The high word of measured data is on External 63	R/W
326	Ext63	The low word of measured data is on External 63	R/W
327	Ext64	The high word of measured data is on External 64	R/W
328	Ext64	The low word of measured data is on External 64	R/W
329	Ext65	The high word of measured data is on External 65	R/W
330	Ext65	The low word of measured data is on External 65	R/W
331	Ext66	The high word of measured data is on External 66	R/W
332	Ext66	The low word of measured data is on External 66	R/W
333	Ext67	The high word of measured data is on External 67	R/W
334	Ext67	The low word of measured data is on External 67	R/W
335	Ext68	The high word of measured data is on External 68	R/W
336	Ext68	The low word of measured data is on External 68	R/W
337	Ext69	The high word of measured data is on External 69	R/W
338	Ext69	The low word of measured data is on External 69	R/W
339	Ext70	The high word of measured data is on External 70	R/W
340	Ext70	The low word of measured data is on External 70	R/W
341	Ext71	The high word of measured data is on External 71	R/W
342	Ext71	The low word of measured data is on External 71	R/W
343	Ext72	The high word of measured data is on External 72	R/W
344	Ext72	The low word of measured data is on External 72	R/W
345	Ext73	The high word of measured data is on External 73	R/W
346	Ext73	The low word of measured data is on External 73	R/W
347	Ext74	The high word of measured data is on External 74	R/W
348	Ext74	The low word of measured data is on External 74	R/W
349	Ext75	The high word of measured data is on External 75	R/W
350	Ext75	The low word of measured data is on External 75	R/W
351	Ext76	The high word of measured data is on External 76	R/W
352	Ext76	The low word of measured data is on External 76	R/W
353	Ext77	The high word of measured data is on External 77	R/W
354	Ext77	The low word of measured data is on External 77	R/W
355	Ext78	The high word of measured data is on External 78	R/W
356	Ext78	The low word of measured data is on External 78	R/W
357	Ext79	The high word of measured data is on External 79	R/W
358	Ext79	The low word of measured data is on External 79	R/W
359	Ext80	The high word of measured data is on External 80	R/W
360	Ext80	The low word of measured data is on External 80	R/W
361	Ext81	The high word of measured data is on External 81	R/W
362	Ext81	The low word of measured data is on External 81	R/W
363	Ext82	The high word of measured data is on External 82	R/W
364	Ext82	The low word of measured data is on External 82	R/W
365	Ext83	The high word of measured data is on External 83	R/W
366	Ext83	The low word of measured data is on External 83	R/W

Modbus Address	Notation	Register Name	Access
367	Ext84	The high word of measured data is on External 84	R/W
368	Ext84	The low word of measured data is on External 84	R/W
369	Ext85	The high word of measured data is on External 85	R/W
370	Ext85	The low word of measured data is on External 85	R/W
371	Ext86	The high word of measured data is on External 86	R/W
372	Ext86	The low word of measured data is on External 86	R/W
373	Ext87	The high word of measured data is on External 87	R/W
374	Ext87	The low word of measured data is on External 87	R/W
375	Ext88	The high word of measured data is on External 88	R/W
376	Ext88	The low word of measured data is on External 88	R/W
377	Ext89	The high word of measured data is on External 89	R/W
378	Ext89	The low word of measured data is on External 89	R/W
379	Ext90	The high word of measured data is on External 90	R/W
380	Ext90	The low word of measured data is on External 90	R/W
381	Ext91	The high word of measured data is on External 91	R/W
382	Ext91	The low word of measured data is on External 91	R/W
383	Ext92	The high word of measured data is on External 92	R/W
384	Ext92	The low word of measured data is on External 92	R/W
385	Ext93	The high word of measured data is on External 93	R/W
386	Ext93	The low word of measured data is on External 93	R/W
387	Ext94	The high word of measured data is on External 94	R/W
388	Ext94	The low word of measured data is on External 94	R/W
389	Ext95	The high word of measured data is on External 95	R/W
390	Ext95	The low word of measured data is on External 95	R/W
391	Ext96	The high word of measured data is on External 96	R/W
392	Ext96	The low word of measured data is on External 96	R/W

Note: If the register value is 4294967294, then there is a communication error.

8.1.2.3 External Channels 4 Bytes Data (Float Type)

Modbus Address	Notation	Register Name	Access
1001	Ext1	Measured data on External 1	R/W
1003	Ext2	Measured data on External 2	R/W
1005	Ext3	Measured data on External 3	R/W
1007	Ext4	Measured data on External 4	R/W
1009	Ext5	Measured data on External 5	R/W
1011	Ext6	Measured data on External 6	R/W
1013	Ext7	Measured data on External 7	R/W
1015	Ext8	Measured data on External 8	R/W
1017	Ext9	Measured data on External 9	R/W
1019	Ext10	Measured data on External 10	R/W
1021	Ext11	Measured data on External 11	R/W
1023	Ext12	Measured data on External 12	R/W
1025	Ext13	Measured data on External 13	R/W
1027	Ext14	Measured data on External 14	R/W
1029	Ext15	Measured data on External 15	R/W
1031	Ext16	Measured data on External 16	R/W
1033	Ext17	Measured data on External 17	R/W
1035	Ext18	Measured data on External 18	R/W
1037	Ext19	Measured data on External 19	R/W
1039	Ext20	Measured data on External 20	R/W
1041	Ext21	Measured data on External 21	R/W
1043	Ext22	Measured data on External 22	R/W
1045	Ext23	Measured data on External 23	R/W

Modbus Address	Notation	Register Name	Access
1047	Ext24	Measured data on External 24	R/W
1049	Ext25	Measured data on External 25	R/W
1051	Ext26	Measured data on External 26	R/W
1053	Ext27	Measured data on External 27	R/W
1055	Ext28	Measured data on External 28	R/W
1057	Ext29	Measured data on External 29	R/W
1059	Ext30	Measured data on External 30	R/W
1061	Ext31	Measured data on External 31	R/W
1063	Ext32	Measured data on External 32	R/W
1065	Ext33	Measured data on External 33	R/W
1067	Ext34	Measured data on External 34	R/W
1069	Ext35	Measured data on External 35	R/W
1071	Ext36	Measured data on External 36	R/W
1073	Ext37	Measured data on External 37	R/W
1075	Ext38	Measured data on External 38	R/W
1077	Ext39	Measured data on External 39	R/W
1079	Ext40	Measured data on External 40	R/W
1081	Ext41	Measured data on External 41	R/W
1083	Ext42	Measured data on External 42	R/W
1085	Ext43	Measured data on External 43	R/W
1087	Ext44	Measured data on External 44	R/W
1089	Ext45	Measured data on External 45	R/W
1091	Ext46	Measured data on External 46	R/W
1093	Ext47	Measured data on External 47	R/W
1095	Ext48	Measured data on External 48	R/W
1097	Ext49	Measured data on External 49	R/W
1099	Ext50	Measured data on External 50	R/W
1101	Ext51	Measured data on External 51	R/W
1103	Ext52	Measured data on External 52	R/W
1105	Ext53	Measured data on External 53	R/W
1107	Ext54	Measured data on External 54	R/W
1109	Ext55	Measured data on External 55	R/W
1111	Ext56	Measured data on External 56	R/W
1113	Ext57	Measured data on External 57	R/W
1115	Ext58	Measured data on External 58	R/W
1117	Ext59	Measured data on External 59	R/W
1119	Ext60	Measured data on External 60	R/W
1121	Ext61	Measured data on External 61	R/W
1123	Ext62	Measured data on External 62	R/W
1125	Ext63	Measured data on External 63	R/W
1127	Ext64	Measured data on External 64	R/W
1129	Ext65	Measured data on External 65	R/W
1131	Ext66	Measured data on External 66	R/W
1133	Ext67	Measured data on External 67	R/W
1135	Ext68	Measured data on External 68	R/W
1137	Ext69	Measured data on External 69	R/W
1139	Ext70	Measured data on External 70	R/W
1141	Ext71	Measured data on External 71	R/W
1143	Ext72	Measured data on External 72	R/W
1145	Ext73	Measured data on External 73	R/W
1147	Ext74	Measured data on External 74	R/W
1149	Ext75	Measured data on External 75	R/W
1151	Ext76	Measured data on External 76	R/W
1153	Ext77	Measured data on External 77	R/W
1155	Ext78	Measured data on External 78	R/W
1157	Ext79	Measured data on External 79	R/W

Modbus Address	Notation	Register Name	Access
1159	Ext80	Measured data on External 80	R/W
1161	Ext81	Measured data on External 81	R/W
1163	Ext82	Measured data on External 82	R/W
1165	Ext83	Measured data on External 83	R/W
1167	Ext84	Measured data on External 84	R/W
1169	Ext85	Measured data on External 85	R/W
1171	Ext86	Measured data on External 86	R/W
1173	Ext87	Measured data on External 87	R/W
1175	Ext88	Measured data on External 88	R/W
1177	Ext89	Measured data on External 89	R/W
1179	Ext90	Measured data on External 90	R/W
1181	Ext91	Measured data on External 91	R/W
1183	Ext92	Measured data on External 92	R/W
1185	Ext93	Measured data on External 93	R/W
1187	Ext94	Measured data on External 94	R/W
1189	Ext95	Measured data on External 95	R/W
1191	Ext96	Measured data on External 96	R/W

Note: If the register value is 3.0+E38, then there is a communication error.

8.1.3 Holding Register Parameter Table for Remote Command

8.1.3.1 Command Data

Modbus Address	Register Name	Note	Access
10002	Start / Stop data log	0 : Stop 1 : Start	R/W
10003	Year	2000 ~ 2030	W
10004	Month	1 ~ 12	W
10005	Day	1 ~ 31	W
10006	Hour	0 ~ 23	W
10007	Minute	0 ~ 59	W
10008	Second	0 ~ 59	W
10102	Batch Name	Include 2 characters for each register ^d	R/W
10103	Batch Name	①	R/W
10104	Batch Name	①	R/W
10105	Batch Name	①	R/W
10106	Batch Name	①	R/W
10107	Batch Name	①	R/W
10108	Batch Name	①	R/W
10109	Batch Name	①	R/W
10110	Batch Name	①	R/W
10111	Batch Name	①	R/W
10112	Batch Name	①	R/W
10113	Batch Name	①	R/W
10114	Batch Name	①	R/W
10115	Batch Name	①	R/W
10116	Batch Name	①	R/W
10117	Batch Name	①	R/W
10118	Batch Name	①	R/W
10119	Batch Name	①	R/W
10120	Lot NO.	1 ~ 65535	R/W
10121	Comment1	Include 2 characters for each register ^d	R/W

Modbus Address	Register Name	Note	Access
10122	Comment1	①	R/W
10123	Comment1	①	R/W
10124	Comment1	①	R/W
10125	Comment1	①	R/W
10126	Comment1	①	R/W
10127	Comment1	①	R/W
10128	Comment1	①	R/W
10129	Comment1	①	R/W
10130	Comment1	①	R/W
10131	Comment1	①	R/W
10132	Comment1	①	R/W
10133	Comment1	①	R/W
10134	Comment1	①	R/W
10135	Comment1	①	R/W
10136	Comment1	①	R/W
10137	Comment1	①	R/W
10138	Comment1	①	R/W
10139	Comment1	①	R/W
10140	Comment1	①	R/W
10141	Comment1	①	R/W
10142	Comment1	①	R/W
10143	Comment1	①	R/W
10144	Comment1	①	R/W
10145	Comment1	①	R/W
10146	Comment1	①	R/W
10147	Comment1	①	R/W
10148	Comment1	①	R/W
10149	Comment1	①	R/W
10150	Comment1	①	R/W
10151	Comment1	①	R/W
10152	Comment1	①	R/W
10153	Comment1	①	R/W
10154	Comment1	①	R/W
10155	Comment1	①	R/W
10156	Comment1	①	R/W
10157	Comment2	①	R/W
10158	Comment2	①	R/W
10159	Comment2	①	R/W
10160	Comment2	①	R/W
10161	Comment2	①	R/W
10162	Comment2	①	R/W
10163	Comment2	①	R/W
10164	Comment2	①	R/W
10165	Comment2	①	R/W
10166	Comment2	①	R/W
10167	Comment2	①	R/W
10168	Comment2	①	R/W
10169	Comment2	①	R/W
10170	Comment2	①	R/W
10171	Comment2	①	R/W
10172	Comment2	①	R/W
10173	Comment2	①	R/W
10174	Comment2	①	R/W
10175	Comment2	①	R/W
10176	Comment2	①	R/W
10177	Comment2	①	R/W

Modbus Address	Register Name	Note	Access
10178	Comment2	①	R/W
10179	Comment2	①	R/W
10180	Comment2	①	R/W
10181	Comment2	①	R/W
10182	Comment2	①	R/W
10183	Comment2	①	R/W
10184	Comment2	①	R/W
10185	Comment2	①	R/W
10186	Comment2	①	R/W
10187	Comment2	①	R/W
10188	Comment2	①	R/W
10189	Comment2	①	R/W
10190	Comment2	①	R/W
10191	Comment2	①	R/W
10192	Comment2	①	R/W
10193	Comment3	①	R/W
10194	Comment3	①	R/W
10195	Comment3	①	R/W
10196	Comment3	①	R/W
10197	Comment3	①	R/W
10198	Comment3	①	R/W
10199	Comment3	①	R/W
10200	Comment3	①	R/W
10201	Comment3	①	R/W
10202	Comment3	①	R/W
10203	Comment3	①	R/W
10204	Comment3	①	R/W
10205	Comment3	①	R/W
10206	Comment3	①	R/W
10207	Comment3	①	R/W
10208	Comment3	①	R/W
10209	Comment3	①	R/W
10210	Comment3	①	R/W
10211	Comment3	①	R/W
10212	Comment3	①	R/W
10213	Comment3	①	R/W
10214	Comment3	①	R/W
10215	Comment3	①	R/W
10216	Comment3	①	R/W
10217	Comment3	①	R/W
10218	Comment3	①	R/W
10219	Comment3	①	R/W
10220	Comment3	①	R/W
10221	Comment3	①	R/W
10222	Comment3	①	R/W
10223	Comment3	①	R/W
10224	Comment3	①	R/W
10225	Comment3	①	R/W
10226	Comment3	①	R/W
10227	Comment3	①	R/W
10228	Comment3	①	R/W
10229	Comment4	①	R/W
10230	Comment4	①	R/W
10231	Comment4	①	R/W
10232	Comment4	①	R/W
10233	Comment4	①	R/W

Modbus Address	Register Name	Note	Access
10234	Comment4	①	R/W
10235	Comment4	①	R/W
10236	Comment4	①	R/W
10237	Comment4	①	R/W
10238	Comment4	①	R/W
10239	Comment4	①	R/W
10240	Comment4	①	R/W
10241	Comment4	①	R/W
10242	Comment4	①	R/W
10243	Comment4	①	R/W
10244	Comment4	①	R/W
10245	Comment4	①	R/W
10246	Comment4	①	R/W
10247	Comment4	①	R/W
10248	Comment4	①	R/W
10249	Comment4	①	R/W
10250	Comment4	①	R/W
10251	Comment4	①	R/W
10252	Comment4	①	R/W
10253	Comment4	①	R/W
10254	Comment4	①	R/W
10255	Comment4	①	R/W
10256	Comment4	①	R/W
10257	Comment4	①	R/W
10258	Comment4	①	R/W
10259	Comment4	①	R/W
10260	Comment4	①	R/W
10261	Comment4	①	R/W
10262	Comment4	①	R/W
10263	Comment4	①	R/W
10264	Comment4	①	R/W
10265	Comment5	①	R/W
10266	Comment5	①	R/W
10267	Comment5	①	R/W
10268	Comment5	①	R/W
10269	Comment5	①	R/W
10270	Comment5	①	R/W
10271	Comment5	①	R/W
10272	Comment5	①	R/W
10273	Comment5	①	R/W
10274	Comment5	①	R/W
10275	Comment5	①	R/W
10276	Comment5	①	R/W
10277	Comment5	①	R/W
10278	Comment5	①	R/W
10279	Comment5	①	R/W
10280	Comment5	①	R/W
10281	Comment5	①	R/W
10282	Comment5	①	R/W
10283	Comment5	①	R/W
10284	Comment5	①	R/W
10285	Comment5	①	R/W
10286	Comment5	①	R/W
10287	Comment5	①	R/W
10288	Comment5	①	R/W
10289	Comment5	①	R/W

Modbus Address	Register Name	Note	Access
10290	Comment5	①	R/W
10291	Comment5	①	R/W
10292	Comment5	①	R/W
10293	Comment5	①	R/W
10294	Comment5	①	R/W
10295	Comment5	①	R/W
10296	Comment5	①	R/W
10297	Comment5	①	R/W
10298	Comment5	①	R/W
10299	Comment5	①	R/W
10300	Comment5	①	R/W
10301	Comment6	①	R/W
10302	Comment6	①	R/W
10303	Comment6	①	R/W
10304	Comment6	①	R/W
10305	Comment6	①	R/W
10306	Comment6	①	R/W
10307	Comment6	①	R/W
10308	Comment6	①	R/W
10309	Comment6	①	R/W
10310	Comment6	①	R/W
10311	Comment6	①	R/W
10312	Comment6	①	R/W
10313	Comment6	①	R/W
10314	Comment6	①	R/W
10315	Comment6	①	R/W
10316	Comment6	①	R/W
10317	Comment6	①	R/W
10318	Comment6	①	R/W
10319	Comment6	①	R/W
10320	Comment6	①	R/W
10321	Comment6	①	R/W
10322	Comment6	①	R/W
10323	Comment6	①	R/W
10324	Comment6	①	R/W
10325	Comment6	①	R/W
10326	Comment6	①	R/W
10327	Comment6	①	R/W
10328	Comment6	①	R/W
10329	Comment6	①	R/W
10330	Comment6	①	R/W
10331	Comment6	①	R/W
10332	Comment6	①	R/W
10333	Comment6	①	R/W
10334	Comment6	①	R/W
10335	Comment6	①	R/W
10336	Comment6	①	R/W
10337	Comment7	①	R/W
10338	Comment7	①	R/W
10339	Comment7	①	R/W
10340	Comment7	①	R/W
10341	Comment7	①	R/W
10342	Comment7	①	R/W
10343	Comment7	①	R/W
10344	Comment7	①	R/W
10345	Comment7	①	R/W

Modbus Address	Register Name	Note	Access
10346	Comment7	①	R/W
10347	Comment7	①	R/W
10348	Comment7	①	R/W
10349	Comment7	①	R/W
10350	Comment7	①	R/W
10351	Comment7	①	R/W
10352	Comment7	①	R/W
10353	Comment7	①	R/W
10354	Comment7	①	R/W
10355	Comment7	①	R/W
10356	Comment7	①	R/W
10357	Comment7	①	R/W
10358	Comment7	①	R/W
10359	Comment7	①	R/W
10360	Comment7	①	R/W
10361	Comment7	①	R/W
10362	Comment7	①	R/W
10363	Comment7	①	R/W
10364	Comment7	①	R/W
10365	Comment7	①	R/W
10366	Comment7	①	R/W
10367	Comment7	①	R/W
10368	Comment7	①	R/W
10369	Comment7	①	R/W
10370	Comment7	①	R/W
10371	Comment7	①	R/W
10372	Comment7	①	R/W
10373	Comment8	①	R/W
10374	Comment8	①	R/W
10375	Comment8	①	R/W
10376	Comment8	①	R/W
10377	Comment8	①	R/W
10378	Comment8	①	R/W
10379	Comment8	①	R/W
10380	Comment8	①	R/W
10381	Comment8	①	R/W
10382	Comment8	①	R/W
10383	Comment8	①	R/W
10384	Comment8	①	R/W
10385	Comment8	①	R/W
10386	Comment8	①	R/W
10387	Comment8	①	R/W
10388	Comment8	①	R/W
10389	Comment8	①	R/W
10390	Comment8	①	R/W
10391	Comment8	①	R/W
10392	Comment8	①	R/W
10393	Comment8	①	R/W
10394	Comment8	①	R/W
10395	Comment8	①	R/W
10396	Comment8	①	R/W
10397	Comment8	①	R/W
10398	Comment8	①	R/W
10399	Comment8	①	R/W
10400	Comment8	①	R/W
10401	Comment8	①	R/W

Modbus Address	Register Name	Note	Access
10402	Comment8	①	R/W
10403	Comment8	①	R/W
10404	Comment8	①	R/W
10405	Comment8	①	R/W
10406	Comment8	①	R/W
10407	Comment8	①	R/W
10408	Comment8	①	R/W
10409	Comment9	①	R/W
10410	Comment9	①	R/W
10411	Comment9	①	R/W
10412	Comment9	①	R/W
10413	Comment9	①	R/W
10414	Comment9	①	R/W
10415	Comment9	①	R/W
10416	Comment9	①	R/W
10417	Comment9	①	R/W
10418	Comment9	①	R/W
10419	Comment9	①	R/W
10420	Comment9	①	R/W
10421	Comment9	①	R/W
10422	Comment9	①	R/W
10423	Comment9	①	R/W
10424	Comment9	①	R/W
10425	Comment9	①	R/W
10426	Comment9	①	R/W
10427	Comment9	①	R/W
10428	Comment9	①	R/W
10429	Comment9	①	R/W
10430	Comment9	①	R/W
10431	Comment9	①	R/W
10432	Comment9	①	R/W
10433	Comment9	①	R/W
10434	Comment9	①	R/W
10435	Comment9	①	R/W
10436	Comment9	①	R/W
10437	Comment9	①	R/W
10438	Comment9	①	R/W
10439	Comment9	①	R/W
10440	Comment9	①	R/W
10441	Comment9	①	R/W
10442	Comment9	①	R/W
10443	Comment9	①	R/W
10444	Comment9	①	R/W
10445	Comment10	①	R/W
10446	Comment10	①	R/W
10447	Comment10	①	R/W
10448	Comment10	①	R/W
10449	Comment10	①	R/W
10450	Comment10	①	R/W
10451	Comment10	①	R/W
10452	Comment10	①	R/W
10453	Comment10	①	R/W
10454	Comment10	①	R/W
10455	Comment10	①	R/W
10456	Comment10	①	R/W
10457	Comment10	①	R/W

Modbus Address	Register Name	Note	Access
10458	Comment10	①	R/W
10459	Comment10	①	R/W
10460	Comment10	①	R/W
10461	Comment10	①	R/W
10462	Comment10	①	R/W
10463	Comment10	①	R/W
10464	Comment10	①	R/W
10465	Comment10	①	R/W
10466	Comment10	①	R/W
10467	Comment10	①	R/W
10468	Comment10	①	R/W
10469	Comment10	①	R/W
10470	Comment10	①	R/W
10471	Comment10	①	R/W
10472	Comment10	①	R/W
10473	Comment10	①	R/W
10474	Comment10	①	R/W
10475	Comment10	①	R/W
10476	Comment10	①	R/W
10477	Comment10	①	R/W
10478	Comment10	①	R/W
10479	Comment10	①	R/W
10480	Comment10	①	R/W
10481	Description	①	R/W
10482	Description	①	R/W
10483	Description	①	R/W
10484	Description	①	R/W
10485	Description	①	R/W
10486	Description	①	R/W
10487	Description	①	R/W
10488	Description	①	R/W
10489	Description	①	R/W
10490	Description	①	R/W
10491	Description	①	R/W
10492	Description	①	R/W
10493	Description	①	R/W
10494	Description	①	R/W
10495	Description	①	R/W
10496	Description	①	R/W
10497	Description	①	R/W
10498	Description	①	R/W
10499	Description	①	R/W
10500	Description	①	R/W
10501	Description	①	R/W
10502	Description	①	R/W
10503	Description	①	R/W
10504	Description	①	R/W
10505	Description	①	R/W
10506	Description	①	R/W
10507	Description	①	R/W
10508	Description	①	R/W
10509	Description	①	R/W
10510	Description	①	R/W
10511	Description	①	R/W
10512	Description	①	R/W
10513	Description	①	R/W

Modbus Address	Register Name	Note	Access
10514	Description	①	R/W
10515	Description	①	R/W
10516	Description	①	R/W
10517	Description	①	R/W
10518	Description	①	R/W
10519	Description	①	R/W
10520	Description	①	R/W
10521	Description	①	R/W
10522	Description	①	R/W
10523	Description	①	R/W
10524	Description	①	R/W
10525	Description	①	R/W
10526	Description	①	R/W
10527	Description	①	R/W
10528	Description	①	R/W
10529	Description	①	R/W
10530	Description	①	R/W

8.1.3.2 Scale Low (Dword Type)

Modbus Address	Register Name	Note	Access
4001	The low word of Scale Low data is on AI1	①	R/W
4002	The high word of Scale Low data is on AI1	①	R/W
4003	The low word of Scale Low data is on AI2	①	R/W
4004	The high word of Scale Low data is on AI2	①	R/W
4005	The low word of Scale Low data is on AI3	①	R/W
4006	The high word of Scale Low data is on AI3	①	R/W
4007	The low word of Scale Low data is on AI4	①	R/W
4008	The high word of Scale Low data is on AI4	①	R/W
4009	The low word of Scale Low data is on AI5	①	R/W
4010	The high word of Scale Low data is on AI5	①	R/W
4011	The low word of Scale Low data is on AI6	①	R/W
4012	The high word of Scale Low data is on AI6	①	R/W
4013	The low word of Scale Low data is on AI7	①	R/W
4014	The high word of Scale Low data is on AI7	①	R/W
4015	The low word of Scale Low data is on AI8	①	R/W
4016	The high word of Scale Low data is on AI8	①	R/W
4017	The low word of Scale Low data is on AI9	①	R/W
4018	The high word of Scale Low data is on AI9	①	R/W
4019	The low word of Scale Low data is on AI10	①	R/W
4020	The high word of Scale Low data is on AI10	①	R/W
4021	The low word of Scale Low data is on AI11	①	R/W
4022	The high word of Scale Low data is on AI11	①	R/W
4023	The low word of Scale Low data is on AI12	①	R/W
4024	The high word of Scale Low data is on AI12	①	R/W
4025	The low word of Scale Low data is on AI13	①	R/W
4026	The high word of Scale Low data is on AI13	①	R/W
4027	The low word of Scale Low data is on AI14	①	R/W
4028	The high word of Scale Low data is on AI14	①	R/W
4029	The low word of Scale Low data is on AI15	①	R/W
4030	The high word of Scale Low data is on AI15	①	R/W
4031	The low word of Scale Low data is on AI16	①	R/W
4032	The high word of Scale Low data is on AI16	①	R/W
4033	The low word of Scale Low data is on AI17	①	R/W
4034	The high word of Scale Low data is on AI17	①	R/W

Modbus Address	Register Name	Note	Access
4035	The low word of Scale Low data is on AI18	①	R/W
4036	The high word of Scale Low data is on AI18	①	R/W
4037	The low word of Scale Low data is on AI19	①	R/W
4038	The high word of Scale Low data is on AI19	①	R/W
4039	The low word of Scale Low data is on AI20	①	R/W
4040	The high word of Scale Low data is on AI20	①	R/W
4041	The low word of Scale Low data is on AI21	①	R/W
4042	The high word of Scale Low data is on AI21	①	R/W
4043	The low word of Scale Low data is on AI22	①	R/W
4044	The high word of Scale Low data is on AI22	①	R/W
4045	The low word of Scale Low data is on AI23	①	R/W
4046	The high word of Scale Low data is on AI23	①	R/W
4047	The low word of Scale Low data is on AI24	①	R/W
4048	The high word of Scale Low data is on AI24	①	R/W
4049	The low word of Scale Low data is on AI25	①	R/W
4050	The high word of Scale Low data is on AI25	①	R/W
4051	The low word of Scale Low data is on AI26	①	R/W
4052	The high word of Scale Low data is on AI26	①	R/W
4053	The low word of Scale Low data is on AI27	①	R/W
4054	The high word of Scale Low data is on AI27	①	R/W
4055	The low word of Scale Low data is on AI28	①	R/W
4056	The high word of Scale Low data is on AI28	①	R/W
4057	The low word of Scale Low data is on AI29	①	R/W
4058	The high word of Scale Low data is on AI29	①	R/W
4059	The low word of Scale Low data is on AI30	①	R/W
4060	The high word of Scale Low data is on AI30	①	R/W
4061	The low word of Scale Low data is on AI31	①	R/W
4062	The high word of Scale Low data is on AI31	①	R/W
4063	The low word of Scale Low data is on AI32	①	R/W
4064	The high word of Scale Low data is on AI32	①	R/W
4065	The low word of Scale Low data is on AI33	①	R/W
4066	The high word of Scale Low data is on AI33	①	R/W
4067	The low word of Scale Low data is on AI34	①	R/W
4068	The high word of Scale Low data is on AI34	①	R/W
4069	The low word of Scale Low data is on AI35	①	R/W
4070	The high word of Scale Low data is on AI35	①	R/W
4071	The low word of Scale Low data is on AI36	①	R/W
4072	The high word of Scale Low data is on AI36	①	R/W
4073	The low word of Scale Low data is on AI37	①	R/W
4074	The high word of Scale Low data is on AI37	①	R/W
4075	The low word of Scale Low data is on AI38	①	R/W
4076	The high word of Scale Low data is on AI38	①	R/W
4077	The low word of Scale Low data is on AI39	①	R/W
4078	The high word of Scale Low data is on AI39	①	R/W
4079	The low word of Scale Low data is on AI40	①	R/W
4080	The high word of Scale Low data is on AI40	①	R/W
4081	The low word of Scale Low data is on AI41	①	R/W
4082	The high word of Scale Low data is on AI41	①	R/W
4083	The low word of Scale Low data is on AI42	①	R/W
4084	The high word of Scale Low data is on AI42	①	R/W
4085	The low word of Scale Low data is on AI43	①	R/W
4086	The high word of Scale Low data is on AI43	①	R/W
4087	The low word of Scale Low data is on AI44	①	R/W
4088	The high word of Scale Low data is on AI44	①	R/W
4089	The low word of Scale Low data is on AI45	①	R/W
4090	The high word of Scale Low data is on AI45	①	R/W

Modbus Address	Register Name	Note	Access
4091	The low word of Scale Low data is on AI46	①	R/W
4492	The high word of Scale Low data is on AI46	①	R/W
4093	The low word of Scale Low data is on AI47	①	R/W
4094	The high word of Scale Low data is on AI47	①	R/W
4095	The low word of Scale Low data is on AI48	①	R/W
4096	The high word of Scale Low data is on AI48	①	R/W
4097	The low word of Scale Low data is on DI1		R
4098	The high word of Scale Low data is on DI1		R
4099	The low word of Scale Low data is on DI2		R
4100	The high word of Scale Low data is on DI2		R
4101	The low word of Scale Low data is on DI3		R
4102	The high word of Scale Low data is on DI3		R
4103	The low word of Scale Low data is on DI4		R
4104	The high word of Scale Low data is on DI4		R
4105	The low word of Scale Low data is on DI5		R
4106	The high word of Scale Low data is on DI5		R
4107	The low word of Scale Low data is on DI6		R
4108	The high word of Scale Low data is on DI6		R
4109	The low word of Scale Low data is on DI7		R
4110	The high word of Scale Low data is on DI7		R
4111	The low word of Scale Low data is on DI8		R
4112	The high word of Scale Low data is on DI8		R
4113	The low word of Scale Low data is on DI9		R
4114	The high word of Scale Low data is on DI9		R
4115	The low word of Scale Low data is on DI10		R
4116	The high word of Scale Low data is on DI10		R
4117	The low word of Scale Low data is on DI11		R
4118	The high word of Scale Low data is on DI11		R
4119	The low word of Scale Low data is on DI12		R
4120	The high word of Scale Low data is on DI12		R
4121	The low word of Scale Low data is on DI13		R
4122	The high word of Scale Low data is on DI13		R
4123	The low word of Scale Low data is on DI14		R
4124	The high word of Scale Low data is on DI14		R
4125	The low word of Scale Low data is on DI15		R
4126	The high word of Scale Low data is on DI15		R
4127	The low word of Scale Low data is on DI16		R
4128	The high word of Scale Low data is on DI16		R
4129	The low word of Scale Low data is on DI17		R
4130	The high word of Scale Low data is on DI17		R
4131	The low word of Scale Low data is on DI18		R
4132	The high word of Scale Low data is on DI18		R
4133	The low word of Scale Low data is on DI19		R
4134	The high word of Scale Low data is on DI19		R
4135	The low word of Scale Low data is on DI20		R
4136	The high word of Scale Low data is on DI20		R
4137	The low word of Scale Low data is on DI21		R
4138	The high word of Scale Low data is on DI21		R
4139	The low word of Scale Low data is on DI22		R
4140	The high word of Scale Low data is on DI22		R
4141	The low word of Scale Low data is on DI23		R
4142	The high word of Scale Low data is on DI23		R
4143	The low word of Scale Low data is on DI24		R
4144	The high word of Scale Low data is on DI24		R
4145	The low word of Scale Low data is on DO1		R
4146	The high word of Scale Low data is on DO1		R

Modbus Address	Register Name	Note	Access
4147	The low word of Scale Low data is on DO2		R
4148	The high word of Scale Low data is on DO2		R
4149	The low word of Scale Low data is on DO3		R
4150	The high word of Scale Low data is on DO3		R
4151	The low word of Scale Low data is on DO4		R
4152	The high word of Scale Low data is on DO4		R
4153	The low word of Scale Low data is on DO5		R
4154	The high word of Scale Low data is on DO5		R
4155	The low word of Scale Low data is on DO6		R
4156	The high word of Scale Low data is on DO6		R
4157	The low word of Scale Low data is on DO7		R
4158	The high word of Scale Low data is on DO7		R
4159	The low word of Scale Low data is on DO8		R
4160	The high word of Scale Low data is on DO8		R
4161	The low word of Scale Low data is on DO9		R
4162	The high word of Scale Low data is on DO9		R
4163	The low word of Scale Low data is on DO10		R
4164	The high word of Scale Low data is on DO10		R
4165	The low word of Scale Low data is on DO11		R
4166	The high word of Scale Low data is on DO11		R
4167	The low word of Scale Low data is on DO12		R
4168	The high word of Scale Low data is on DO12		R
4169	The low word of Scale Low data is on DO13		R
4170	The high word of Scale Low data is on DO13		R
4171	The low word of Scale Low data is on DO14		R
4172	The high word of Scale Low data is on DO14		R
4173	The low word of Scale Low data is on DO15		R
4174	The high word of Scale Low data is on DO15		R
4175	The low word of Scale Low data is on DO16		R
4176	The high word of Scale Low data is on DO16		R
4177	The low word of Scale Low data is on DO17		R
4178	The high word of Scale Low data is on DO17		R
4179	The low word of Scale Low data is on DO18		R
4180	The high word of Scale Low data is on DO18		R
4181	The low word of Scale Low data is on DO19		R
4182	The high word of Scale Low data is on DO19		R
4183	The low word of Scale Low data is on DO20		R
4184	The high word of Scale Low data is on DO20		R
4185	The low word of Scale Low data is on DO21		R
4186	The high word of Scale Low data is on DO21		R
4187	The low word of Scale Low data is on DO22		R
4188	The high word of Scale Low data is on DO22		R
4189	The low word of Scale Low data is on DO23		R
4190	The high word of Scale Low data is on DO23		R
4191	The low word of Scale Low data is on DO24		R
4192	The high word of Scale Low data is on DO24		R
4193	The low word of Scale Low data is on AO1		R
4194	The high word of Scale Low data is on AO1		R
4195	The low word of Scale Low data is on AO2		R
4196	The high word of Scale Low data is on AO2		R
4197	The low word of Scale Low data is on AO3		R
4198	The high word of Scale Low data is on AO3		R
4199	The low word of Scale Low data is on AO4		R
4200	The high word of Scale Low data is on AO4		R
4201	The low word of Scale Low data is on AO5		R
4202	The high word of Scale Low data is on AO5		R

Modbus Address	Register Name	Note	Access
4203	The low word of Scale Low data is on AO6		R
4204	The high word of Scale Low data is on AO6		R
4205	The low word of Scale Low data is on AO7		R
4206	The high word of Scale Low data is on AO7		R
4207	The low word of Scale Low data is on AO8		R
4208	The high word of Scale Low data is on AO8		R
4209	The low word of Scale Low data is on AO9		R
4210	The high word of Scale Low data is on AO9		R
4211	The low word of Scale Low data is on AO10		R
4212	The high word of Scale Low data is on AO10		R
4213	The low word of Scale Low data is on AO11		R
4214	The high word of Scale Low data is on AO11		R
4215	The low word of Scale Low data is on AO12		R
4216	The high word of Scale Low data is on AO12		R
4217	The low word of Scale Low data is on Math1		R
4218	The high word of Scale Low data is on Math1		R
4219	The low word of Scale Low data is on Math2		R
4220	The high word of Scale Low data is on Math2		R
4221	The low word of Scale Low data is on Math3		R
4222	The high word of Scale Low data is on Math3		R
4223	The low word of Scale Low data is on Math4		R
4224	The high word of Scale Low data is on Math4		R
4225	The low word of Scale Low data is on Math5		R
4226	The high word of Scale Low data is on Math5		R
4227	The low word of Scale Low data is on Math6		R
4228	The high word of Scale Low data is on Math6		R
4229	The low word of Scale Low data is on Math7		R
4230	The high word of Scale Low data is on Math7		R
4231	The low word of Scale Low data is on Math8		R
4232	The high word of Scale Low data is on Math8		R
4233	The low word of Scale Low data is on Math9		R
4234	The high word of Scale Low data is on Math9		R
4235	The low word of Scale Low data is on Math10		R
4236	The high word of Scale Low data is on Math10		R
4237	The low word of Scale Low data is on Math11		R
4238	The high word of Scale Low data is on Math11		R
4239	The low word of Scale Low data is on Math12		R
4240	The high word of Scale Low data is on Math12		R
4241	The low word of Scale Low data is on Math13		R
4242	The high word of Scale Low data is on Math13		R
4243	The low word of Scale Low data is on Math14		R
4244	The high word of Scale Low data is on Math14		R
4245	The low word of Scale Low data is on Math15		R
4246	The high word of Scale Low data is on Math15		R
4247	The low word of Scale Low data is on Math16		R
4248	The high word of Scale Low data is on Math16		R
4249	The low word of Scale Low data is on Math17		R
4250	The high word of Scale Low data is on Math17		R
4251	The low word of Scale Low data is on Math18		R
4252	The high word of Scale Low data is on Math18		R
4253	The low word of Scale Low data is on Math19		R
4254	The high word of Scale Low data is on Math19		R
4255	The low word of Scale Low data is on Math20		R
4256	The high word of Scale Low data is on Math20		R
4257	The low word of Scale Low data is on Math21		R
4258	The high word of Scale Low data is on Math21		R

Modbus Address	Register Name	Note	Access
4259	The low word of Scale Low data is on Math22		R
4260	The high word of Scale Low data is on Math22		R
4261	The low word of Scale Low data is on Math23		R
4262	The high word of Scale Low data is on Math23		R
4263	The low word of Scale Low data is on Math24		R
4264	The high word of Scale Low data is on Math24		R
4265	The low word of Scale Low data is on Math25	Maximum : 5	R
4266	The high word of Scale Low data is on Math25		R
4267	The low word of Scale Low data is on Math26		R
4268	The high word of Scale Low data is on Math26		R
4269	The low word of Scale Low data is on Math27		R
4270	The high word of Scale Low data is on Math27		R
4271	The low word of Scale Low data is on Math28		R
4272	The high word of Scale Low data is on Math28		R
4273	The low word of Scale Low data is on Math29		R
4274	The high word of Scale Low data is on Math29		R
4275	The low word of Scale Low data is on Math30		R
4276	The high word of Scale Low data is on Math30		R
4277	The low word of Scale Low data is on Math31		R
4278	The high word of Scale Low data is on Math31		R
4279	The low word of Scale Low data is on Math32		R
4280	The high word of Scale Low data is on Math32		R
4281	The low word of Scale Low data is on Math33		R
4282	The high word of Scale Low data is on Math33		R
4283	The low word of Scale Low data is on Math34		R
4284	The high word of Scale Low data is on Math34		R
4285	The low word of Scale Low data is on Math35		R
4286	The high word of Scale Low data is on Math35		R
4287	The low word of Scale Low data is on Math36		R
4288	The high word of Scale Low data is on Math36		R
4289	The low word of Scale Low data is on Math37		R
4290	The high word of Scale Low data is on Math37		R
4291	The low word of Scale Low data is on Math38		R
4292	The high word of Scale Low data is on Math38		R
4293	The low word of Scale Low data is on Math39		R
4294	The high word of Scale Low data is on Math39		R
4295	The low word of Scale Low data is on Math40		R
4296	The high word of Scale Low data is on Math40		R
4297	The low word of Scale Low data is on Math41		R
4298	The high word of Scale Low data is on Math41		R
4299	The low word of Scale Low data is on Math42		R
4300	The high word of Scale Low data is on Math42		R
4301	The low word of Scale Low data is on Math43		R
4302	The high word of Scale Low data is on Math43		R
4303	The low word of Scale Low data is on Math44		R
4304	The high word of Scale Low data is on Math44		R
4305	The low word of Scale Low data is on Math45		R
4306	The high word of Scale Low data is on Math45		R
4307	The low word of Scale Low data is on Math46		R
4308	The high word of Scale Low data is on Math46		R
4309	The low word of Scale Low data is on Math47		R
4310	The high word of Scale Low data is on Math47		R
4311	The low word of Scale Low data is on Math48		R
4312	The high word of Scale Low data is on Math48		R
4313	The low word of Scale Low data is on Math49		R
4314	The high word of Scale Low data is on Math49		R

Modbus Address	Register Name	Note	Access
4315	The low word of Scale Low data is on Math50		R
4316	The high word of Scale Low data is on Math50		R
4317	The low word of Scale Low data is on Math51		R
4318	The high word of Scale Low data is on Math51		R
4319	The low word of Scale Low data is on Math52		R
4320	The high word of Scale Low data is on Math52		R
4321	The low word of Scale Low data is on Math53		R
4322	The high word of Scale Low data is on Math53		R
4323	The low word of Scale Low data is on Math54		R
4324	The high word of Scale Low data is on Math54		R
4325	The low word of Scale Low data is on Math55		R
4326	The high word of Scale Low data is on Math55		R
4327	The low word of Scale Low data is on Math56		R
4328	The high word of Scale Low data is on Math56		R
4329	The low word of Scale Low data is on Math57		R
4330	The high word of Scale Low data is on Math57		R
4331	The low word of Scale Low data is on Math58		R
4332	The high word of Scale Low data is on Math58		R
4333	The low word of Scale Low data is on Math59		R
4334	The high word of Scale Low data is on Math59		R
4335	The low word of Scale Low data is on Math60		R
4336	The high word of Scale Low data is on Math60		R
4337	The low word of Scale Low data is on Ext1		R
4338	The high word of Scale Low data is on Ext1		R
4339	The low word of Scale Low data is on Ext2		R
4340	The high word of Scale Low data is on Ext2		R
4341	The low word of Scale Low data is on Ext3		R
4342	The high word of Scale Low data is on Ext3		R
4343	The low word of Scale Low data is on Ext4		R
4344	The high word of Scale Low data is on Ext4		R
4345	The low word of Scale Low data is on Ext5		R
4346	The high word of Scale Low data is on Ext5		R
4347	The low word of Scale Low data is on Ext6		R
4348	The high word of Scale Low data is on Ext6		R
4349	The low word of Scale Low data is on Ext7		R
4350	The high word of Scale Low data is on Ext7		R
4351	The low word of Scale Low data is on Ext8		R
4352	The high word of Scale Low data is on Ext8		R
4353	The low word of Scale Low data is on Ext9		R
4354	The high word of Scale Low data is on Ext9		R
4355	The low word of Scale Low data is on Ext10		R
4356	The high word of Scale Low data is on Ext10		R
4357	The low word of Scale Low data is on Ext11		R
4358	The high word of Scale Low data is on Ext11		R
4359	The low word of Scale Low data is on Ext12		R
4360	The high word of Scale Low data is on Ext12		R
4361	The low word of Scale Low data is on Ext13		R
4362	The high word of Scale Low data is on Ext13		R
4363	The low word of Scale Low data is on Ext14		R
4364	The high word of Scale Low data is on Ext14		R
4365	The low word of Scale Low data is on Ext15		R
4366	The high word of Scale Low data is on Ext15		R
4367	The low word of Scale Low data is on Ext16		R
4368	The high word of Scale Low data is on Ext16		R
4369	The low word of Scale Low data is on Ext17		R
4370	The high word of Scale Low data is on Ext17		R

Modbus Address	Register Name	Note	Access
4371	The low word of Scale Low data is on Ext18		R
4372	The high word of Scale Low data is on Ext18		R
4373	The low word of Scale Low data is on Ext19		R
4374	The high word of Scale Low data is on Ext19		R
4375	The low word of Scale Low data is on Ext20		R
4376	The high word of Scale Low data is on Ext20		R
4377	The low word of Scale Low data is on Ext21		R
4378	The high word of Scale Low data is on Ext21		R
4379	The low word of Scale Low data is on Ext22		R
4380	The high word of Scale Low data is on Ext22		R
4381	The low word of Scale Low data is on Ext23		R
4382	The high word of Scale Low data is on Ext23		R
4383	The low word of Scale Low data is on Ext24		R
4384	The high word of Scale Low data is on Ext24		R
4385	The low word of Scale Low data is on Ext25		R
4386	The high word of Scale Low data is on Ext25		R
4387	The low word of Scale Low data is on Ext26		R
4388	The high word of Scale Low data is on Ext26		R
4389	The low word of Scale Low data is on Ext27		R
4390	The high word of Scale Low data is on Ext27		R
4391	The low word of Scale Low data is on Ext28		R
4392	The high word of Scale Low data is on Ext28		R
4393	The low word of Scale Low data is on Ext29		R
4394	The high word of Scale Low data is on Ext29		R
4395	The low word of Scale Low data is on Ext30		R
4396	The high word of Scale Low data is on Ext30		R
4397	The low word of Scale Low data is on Ext31		R
4398	The high word of Scale Low data is on Ext31		R
4399	The low word of Scale Low data is on Ext32		R
4400	The high word of Scale Low data is on Ext32		R
4401	The low word of Scale Low data is on Ext33		R
4402	The high word of Scale Low data is on Ext33		R
4403	The low word of Scale Low data is on Ext34		R
4404	The high word of Scale Low data is on Ext34		R
4405	The low word of Scale Low data is on Ext35		R
4406	The high word of Scale Low data is on Ext35		R
4407	The low word of Scale Low data is on Ext36		R
4408	The high word of Scale Low data is on Ext36		R
4409	The low word of Scale Low data is on Ext37		R
4410	The high word of Scale Low data is on Ext37		R
4411	The low word of Scale Low data is on Ext38		R
4412	The high word of Scale Low data is on Ext38		R
4413	The low word of Scale Low data is on Ext39		R
4414	The high word of Scale Low data is on Ext39		R
4415	The low word of Scale Low data is on Ext40		R
4416	The high word of Scale Low data is on Ext40		R
4417	The low word of Scale Low data is on Ext41		R
4418	The high word of Scale Low data is on Ext41		R
4419	The low word of Scale Low data is on Ext42		R
4420	The high word of Scale Low data is on Ext42		R
4421	The low word of Scale Low data is on Ext43		R
4422	The high word of Scale Low data is on Ext43		R
4423	The low word of Scale Low data is on Ext44		R
4424	The high word of Scale Low data is on Ext44		R
4425	The low word of Scale Low data is on Ext45		R
4426	The high word of Scale Low data is on Ext45		R

Modbus Address	Register Name	Note	Access
4427	The low word of Scale Low data is on Ext46		R
4428	The high word of Scale Low data is on Ext46		R
4429	The low word of Scale Low data is on Ext47		R
4430	The high word of Scale Low data is on Ext47		R
4431	The low word of Scale Low data is on Ext48		R
4432	The high word of Scale Low data is on Ext48		R
4433	The low word of Scale Low data is on Ext49		R
4434	The high word of Scale Low data is on Ext49		R
4435	The low word of Scale Low data is on Ext50		R
4436	The high word of Scale Low data is on Ext50		R
4437	The low word of Scale Low data is on Ext51		R
4438	The high word of Scale Low data is on Ext51		R
4439	The low word of Scale Low data is on Ext52		R
4440	The high word of Scale Low data is on Ext52		R
4441	The low word of Scale Low data is on Ext53		R
4442	The high word of Scale Low data is on Ext53		R
4443	The low word of Scale Low data is on Ext54		R
4444	The high word of Scale Low data is on Ext54		R
4445	The low word of Scale Low data is on Ext55		R
4446	The high word of Scale Low data is on Ext55		R
4447	The low word of Scale Low data is on Ext56		R
4448	The high word of Scale Low data is on Ext56		R
4449	The low word of Scale Low data is on Ext57		R
4450	The high word of Scale Low data is on Ext57		R
4451	The low word of Scale Low data is on Ext58		R
4452	The high word of Scale Low data is on Ext58		R
4453	The low word of Scale Low data is on Ext59		R
4454	The high word of Scale Low data is on Ext59		R
4455	The low word of Scale Low data is on Ext60		R
4456	The high word of Scale Low data is on Ext60		R
4457	The low word of Scale Low data is on Ext61		R
4458	The high word of Scale Low data is on Ext61		R
4459	The low word of Scale Low data is on Ext62		R
4460	The high word of Scale Low data is on Ext62		R
4461	The low word of Scale Low data is on Ext63		R
4462	The high word of Scale Low data is on Ext63		R
4463	The low word of Scale Low data is on Ext64		R
4464	The high word of Scale Low data is on Ext64		R
4465	The low word of Scale Low data is on Ext65		R
4466	The high word of Scale Low data is on Ext65		R
4467	The low word of Scale Low data is on Ext66		R
4468	The high word of Scale Low data is on Ext66		R
4469	The low word of Scale Low data is on Ext67		R
4470	The high word of Scale Low data is on Ext67		R
4471	The low word of Scale Low data is on Ext68		R
4472	The high word of Scale Low data is on Ext68		R
4473	The low word of Scale Low data is on Ext69		R
4474	The high word of Scale Low data is on Ext69		R
4475	The low word of Scale Low data is on Ext70		R
4476	The high word of Scale Low data is on Ext70		R
4477	The low word of Scale Low data is on Ext71		R
4478	The high word of Scale Low data is on Ext71		R
4479	The low word of Scale Low data is on Ext72		R
4480	The high word of Scale Low data is on Ext72		R
4481	The low word of Scale Low data is on Ext73		R
4482	The high word of Scale Low data is on Ext73		R

Modbus Address	Register Name	Note	Access
4483	The low word of Scale Low data is on Ext74		R
4484	The high word of Scale Low data is on Ext74		R
4485	The low word of Scale Low data is on Ext75		R
4486	The high word of Scale Low data is on Ext75		R
4487	The low word of Scale Low data is on Ext76		R
4488	The high word of Scale Low data is on Ext76		R
4489	The low word of Scale Low data is on Ext77		R
4490	The high word of Scale Low data is on Ext77		R
4491	The low word of Scale Low data is on Ext78		R
4492	The high word of Scale Low data is on Ext78		R
4493	The low word of Scale Low data is on Ext79		R
4494	The high word of Scale Low data is on Ext79		R
4495	The low word of Scale Low data is on Ext80		R
4496	The high word of Scale Low data is on Ext80		R
4497	The low word of Scale Low data is on Ext81		R
4498	The high word of Scale Low data is on Ext81		R
4499	The low word of Scale Low data is on Ext82		R
4500	The high word of Scale Low data is on Ext82		R
4501	The low word of Scale Low data is on Ext83		R
4502	The high word of Scale Low data is on Ext83		R
4503	The low word of Scale Low data is on Ext84		R
4504	The high word of Scale Low data is on Ext84		R
4505	The low word of Scale Low data is on Ext85		R
4506	The high word of Scale Low data is on Ext85		R
4507	The low word of Scale Low data is on Ext86		R
4508	The high word of Scale Low data is on Ext86		R
4509	The low word of Scale Low data is on Ext87		R
4510	The high word of Scale Low data is on Ext87		R
4511	The low word of Scale Low data is on Ext88		R
4512	The high word of Scale Low data is on Ext88		R
4513	The low word of Scale Low data is on Ext89		R
4514	The high word of Scale Low data is on Ext89		R
4515	The low word of Scale Low data is on Ext90		R
4516	The high word of Scale Low data is on Ext90		R
4517	The low word of Scale Low data is on Ext91		R
4518	The high word of Scale Low data is on Ext91		R
4519	The low word of Scale Low data is on Ext92		R
4520	The high word of Scale Low data is on Ext92		R
4521	The low word of Scale Low data is on Ext93		R
4522	The high word of Scale Low data is on Ext93		R
4523	The low word of Scale Low data is on Ext94		R
4524	The high word of Scale Low data is on Ext94		R
4525	The low word of Scale Low data is on Ext95		R
4526	The high word of Scale Low data is on Ext95		R
4527	The low word of Scale Low data is on Ext96		R
4528	The high word of Scale Low data is on Ext96		R

8.1.3.3 Scale High (Dword Type)

Modbus Address	Register Name	Note	Access
6001	The low word of Scale High data is on AI1	①	R/W
6002	The high word of Scale High data is on AI1	①	R/W
6003	The low word of Scale High data is on AI2	①	R/W
6004	The high word of Scale High data is on AI2	①	R/W
6005	The low word of Scale High data is on AI3	①	R/W
6006	The high word of Scale High data is on AI3	①	R/W
6007	The low word of Scale High data is on AI4	①	R/W
6008	The high word of Scale High data is on AI4	①	R/W
6009	The low word of Scale High data is on AI5	①	R/W
6010	The high word of Scale High data is on AI5	①	R/W
6011	The low word of Scale High data is on AI6	①	R/W
6012	The high word of Scale High data is on AI6	①	R/W
6013	The low word of Scale High data is on AI7	①	R/W
6014	The high word of Scale High data is on AI7	①	R/W
6015	The low word of Scale High data is on AI8	①	R/W
6016	The high word of Scale High data is on AI8	①	R/W
6017	The low word of Scale High data is on AI9	①	R/W
6018	The high word of Scale High data is on AI9	①	R/W
6019	The low word of Scale High data is on AI10	①	R/W
6020	The high word of Scale High data is on AI10	①	R/W
6021	The low word of Scale High data is on AI11	①	R/W
6022	The high word of Scale High data is on AI11	①	R/W
6023	The low word of Scale High data is on AI12	①	R/W
6024	The high word of Scale High data is on AI12	①	R/W
6025	The low word of Scale High data is on AI13	①	R/W
6026	The high word of Scale Low data is on AI13	①	R/W
6027	The low word of Scale High data is on AI14	①	R/W
6028	The high word of Scale High data is on AI14	①	R/W
6029	The low word of Scale High data is on AI15	①	R/W
6030	The high word of Scale High data is on AI15	①	R/W
6031	The low word of Scale High data is on AI16	①	R/W
6032	The high word of Scale High data is on AI16	①	R/W
6033	The low word of Scale High data is on AI17	①	R/W
6034	The high word of Scale High data is on AI17	①	R/W
6035	The low word of Scale High data is on AI18	①	R/W
6036	The high word of Scale High data is on AI18	①	R/W
6037	The low word of Scale High data is on AI19	①	R/W
6038	The high word of Scale High data is on AI19	①	R/W
6039	The low word of Scale High data is on AI20	①	R/W
6040	The high word of Scale High data is on AI20	①	R/W
6041	The low word of Scale High data is on AI21	①	R/W
6042	The high word of Scale High data is on AI21	①	R/W
6043	The low word of Scale High data is on AI22	①	R/W
6044	The high word of Scale High data is on AI22	①	R/W
6045	The low word of Scale High data is on AI23	①	R/W
6046	The high word of Scale High data is on AI23	①	R/W
6047	The low word of Scale High data is on AI24	①	R/W
6048	The high word of Scale High data is on AI24	①	R/W
6049	The low word of Scale High data is on AI25	①	R/W
6050	The high word of Scale High data is on AI25	①	R/W
6051	The low word of Scale High data is on AI26	①	R/W
6052	The high word of Scale High data is on AI26	①	R/W
6053	The low word of Scale High data is on AI27	①	R/W
6054	The high word of Scale High data is on AI27	①	R/W

Modbus Address	Register Name	Note	Access
6055	The low word of Scale High data is on AI28	①	R/W
6056	The high word of Scale High data is on AI28	①	R/W
6057	The low word of Scale High data is on AI29	①	R/W
6058	The high word of Scale High data is on AI29	①	R/W
6059	The low word of Scale High data is on AI30	①	R/W
6060	The high word of Scale High data is on AI30	①	R/W
6061	The low word of Scale High data is on AI31	①	R/W
6062	The high word of Scale High data is on AI31	①	R/W
6063	The low word of Scale High data is on AI32	①	R/W
6064	The high word of Scale High data is on AI32	①	R/W
6065	The low word of Scale High data is on AI33	①	R/W
6066	The high word of Scale High data is on AI33	①	R/W
6067	The low word of Scale High data is on AI34	①	R/W
6068	The high word of Scale High data is on AI34	①	R/W
6069	The low word of Scale High data is on AI35	①	R/W
6070	The high word of Scale High data is on AI35	①	R/W
6071	The low word of Scale High data is on AI36	①	R/W
6072	The high word of Scale High data is on AI36	①	R/W
6073	The low word of Scale High data is on AI37	①	R/W
6074	The high word of Scale High data is on AI37	①	R/W
6075	The low word of Scale High data is on AI38	①	R/W
6076	The high word of Scale High data is on AI38	①	R/W
6077	The low word of Scale High data is on AI39	①	R/W
6078	The high word of Scale High data is on AI39	①	R/W
6079	The low word of Scale High data is on AI40	①	R/W
6080	The high word of Scale High data is on AI40	①	R/W
6081	The low word of Scale High data is on AI41	①	R/W
6082	The high word of Scale High data is on AI41	①	R/W
6083	The low word of Scale High data is on AI42	①	R/W
6084	The high word of Scale High data is on AI42	①	R/W
6085	The low word of Scale High data is on AI43	①	R/W
6086	The high word of Scale High data is on AI43	①	R/W
6087	The low word of Scale High data is on AI44	①	R/W
6088	The high word of Scale High data is on AI44	①	R/W
6089	The low word of Scale High data is on AI45	①	R/W
6090	The high word of Scale High data is on AI45	①	R/W
6091	The low word of Scale High data is on AI46	①	R/W
6492	The high word of Scale High data is on AI46	①	R/W
6093	The low word of Scale High data is on AI47	①	R/W
6094	The high word of Scale High data is on AI47	①	R/W
6095	The low word of Scale High data is on AI48	①	R/W
6096	The high word of Scale High data is on AI48	①	R/W
6097	The low word of Scale High data is on DI1		R
6098	The high word of Scale High data is on DI1		R
6099	The low word of Scale High data is on DI2		R
6100	The high word of Scale High data is on DI2		R
6101	The low word of Scale High data is on DI3		R
6102	The high word of Scale High data is on DI3		R
6103	The low word of Scale High data is on DI4		R
6104	The high word of Scale High data is on DI4		R
6105	The low word of Scale High data is on DI5		R
6106	The high word of Scale High data is on DI5		R
6107	The low word of Scale High data is on DI6		R
6108	The high word of Scale High data is on DI6		R
6109	The low word of Scale High data is on DI7		R
6110	The high word of Scale High data is on DI7		R

Modbus Address	Register Name	Note	Access
6111	The low word of Scale High data is on DI8		R
6112	The high word of Scale High data is on DI8		R
6113	The low word of Scale High data is on DI9		R
6114	The high word of Scale High data is on DI9		R
6115	The low word of Scale High data is on DI10		R
6116	The high word of Scale High data is on DI10		R
6117	The low word of Scale High data is on DI11		R
6118	The high word of Scale High data is on DI11		R
6119	The low word of Scale High data is on DI12		R
6120	The high word of Scale High data is on DI12		R
6121	The low word of Scale High data is on DI13		R
6122	The high word of Scale High data is on DI13		R
6123	The low word of Scale High data is on DI14		R
6124	The high word of Scale High data is on DI14		R
6125	The low word of Scale High data is on DI15		R
6126	The high word of Scale High data is on DI15		R
6127	The low word of Scale High data is on DI16		R
6128	The high word of Scale High data is on DI16		R
6129	The low word of Scale High data is on DI17		R
6130	The high word of Scale High data is on DI17		R
6131	The low word of Scale High data is on DI18		R
6132	The high word of Scale High data is on DI18		R
6133	The low word of Scale High data is on DI19		R
6134	The high word of Scale High data is on DI19		R
6135	The low word of Scale High data is on DI20		R
6136	The high word of Scale High data is on DI20		R
6137	The low word of Scale High data is on DI21		R
6138	The high word of Scale High data is on DI21		R
6139	The low word of Scale High data is on DI22		R
6140	The high word of Scale High data is on DI22		R
6141	The low word of Scale High data is on DI23		R
6142	The high word of Scale High data is on DI23		R
6143	The low word of Scale High data is on DI24		R
6144	The high word of Scale High data is on DI24		R
6145	The low word of Scale High data is on DO1		R
6146	The high word of Scale High data is on DO1		R
6147	The low word of Scale High data is on DO2		R
6148	The high word of Scale High data is on DO2		R
6149	The low word of Scale High data is on DO3		R
6150	The high word of Scale High data is on DO3		R
6151	The low word of Scale High data is on DO4		R
6152	The high word of Scale High data is on DO4		R
6153	The low word of Scale High data is on DO5		R
6154	The high word of Scale High data is on DO5		R
6155	The low word of Scale High data is on DO6		R
6156	The high word of Scale High data is on DO6		R
6157	The low word of Scale High data is on DO7		R
6158	The high word of Scale High data is on DO7		R
6159	The low word of Scale High data is on DO8		R
6160	The high word of Scale High data is on DO8		R
6161	The low word of Scale High data is on DO9		R
6162	The high word of Scale High data is on DO9		R
6163	The low word of Scale High data is on DO10		R
6164	The high word of Scale High data is on DO10		R
6165	The low word of Scale High data is on DO11		R
6166	The high word of Scale High data is on DO11		R

Modbus Address	Register Name	Note	Access
6167	The low word of Scale High data is on DO12		R
6168	The high word of Scale High data is on DO12		R
6169	The low word of Scale High data is on DO13		R
6170	The high word of Scale High data is on DO13		R
6171	The low word of Scale High data is on DO14		R
6172	The high word of Scale High data is on DO14		R
6173	The low word of Scale High data is on DO15		R
6174	The high word of Scale High data is on DO15		R
6175	The low word of Scale High data is on DO16		R
6176	The high word of Scale High data is on DO16		R
6177	The low word of Scale High data is on DO17		R
6178	The high word of Scale High data is on DO17		R
6179	The low word of Scale High data is on DO18		R
6180	The high word of Scale High data is on DO18		R
6181	The low word of Scale High data is on DO19		R
6182	The high word of Scale High data is on DO19		R
6183	The low word of Scale High data is on DO20		R
6184	The high word of Scale High data is on DO20		R
6185	The low word of Scale High data is on DO21		R
6186	The high word of Scale High data is on DO21		R
6187	The low word of Scale High data is on DO22		R
6188	The high word of Scale High data is on DO22		R
6189	The low word of Scale High data is on DO23		R
6190	The high word of Scale High data is on DO23		R
6191	The low word of Scale High data is on DO24		R
6192	The high word of Scale High data is on DO24		R
6193	The low word of Scale High data is on AO1		R
6194	The high word of Scale High data is on AO1		R
6195	The low word of Scale High data is on AO2		R
6196	The high word of Scale High data is on AO2		R
6197	The low word of Scale High data is on AO3		R
6198	The high word of Scale High data is on AO3		R
6199	The low word of Scale High data is on AO4		R
6200	The high word of Scale High data is on AO4		R
6201	The low word of Scale High data is on AO5		R
6202	The high word of Scale High data is on AO5		R
6203	The low word of Scale High data is on AO6		R
6204	The high word of Scale High data is on AO6		R
6205	The low word of Scale High data is on AO7		R
6206	The high word of Scale High data is on AO7		R
6207	The low word of Scale High data is on AO8		R
6208	The high word of Scale High data is on AO8		R
6209	The low word of Scale High data is on AO9		R
6210	The high word of Scale High data is on AO9		R
6211	The low word of Scale High data is on AO10		R
6212	The high word of Scale High data is on AO10		R
6213	The low word of Scale High data is on AO11		R
6214	The high word of Scale High data is on AO11		R
6215	The low word of Scale High data is on AO12		R
6216	The high word of Scale High data is on AO12		R
6217	The low word of Scale High data is on Math1		R
6218	The high word of Scale High data is on Math1		R
6219	The low word of Scale High data is on Math2		R
6220	The high word of Scale High data is on Math2		R
6221	The low word of Scale High data is on Math3		R
6222	The high word of Scale High data is on Math3		R

Modbus Address	Register Name	Note	Access
6223	The low word of Scale High data is on Math4		R
6224	The high word of Scale High data is on Math4		R
6225	The low word of Scale High data is on Math5		R
6226	The high word of Scale High data is on Math5		R
6227	The low word of Scale High data is on Math6		R
6228	The high word of Scale High data is on Math6		R
6229	The low word of Scale High data is on Math7		R
6230	The high word of Scale High data is on Math7		R
6231	The low word of Scale High data is on Math8		R
6232	The high word of Scale High data is on Math8		R
6233	The low word of Scale High data is on Math9		R
6234	The high word of Scale High data is on Math9		R
6235	The low word of Scale High data is on Math10		R
6236	The high word of Scale High data is on Math10		R
6237	The low word of Scale High data is on Math11		R
6238	The high word of Scale High data is on Math11		R
6239	The low word of Scale High data is on Math12		R
6240	The high word of Scale High data is on Math12		R
6241	The low word of Scale High data is on Math13		R
6242	The high word of Scale High data is on Math13		R
6243	The low word of Scale High data is on Math14		R
6244	The high word of Scale High data is on Math14		R
6245	The low word of Scale High data is on Math15		R
6246	The high word of Scale High data is on Math15		R
6247	The low word of Scale High data is on Math16		R
6248	The high word of Scale High data is on Math16		R
6249	The low word of Scale High data is on Math17		R
6250	The high word of Scale High data is on Math17		R
6251	The low word of Scale High data is on Math18		R
6252	The high word of Scale High data is on Math18		R
6253	The low word of Scale High data is on Math19		R
6254	The high word of Scale High data is on Math19		R
6255	The low word of Scale High data is on Math20		R
6256	The high word of Scale High data is on Math20		R
6257	The low word of Scale High data is on Math21		R
6258	The high word of Scale High data is on Math21		R
6259	The low word of Scale High data is on Math22		R
6260	The high word of Scale High data is on Math22		R
6261	The low word of Scale High data is on Math23		R
6262	The high word of Scale High data is on Math23		R
6263	The low word of Scale High data is on Math24		R
6264	The high word of Scale High data is on Math24		R
6265	The low word of Scale High data is on Math25	Maximum : 5	R
6266	The high word of Scale High data is on Math25		R
6267	The low word of Scale High data is on Math26		R
6268	The high word of Scale High data is on Math26		R
6269	The low word of Scale High data is on Math27		R
6270	The high word of Scale High data is on Math27		R
6271	The low word of Scale High data is on Math28		R
6272	The high word of Scale High data is on Math28		R
6273	The low word of Scale High data is on Math29		R
6274	The high word of Scale High data is on Math29		R
6275	The low word of Scale High data is on Math30		R
6276	The high word of Scale High data is on Math30		R
6277	The low word of Scale High data is on Math31		R
6278	The high word of Scale High data is on Math31		R

Modbus Address	Register Name	Note	Access
6279	The low word of Scale High data is on Math32		R
6280	The high word of Scale High data is on Math32		R
6281	The low word of Scale High data is on Math33		R
6282	The high word of Scale High data is on Math33		R
6283	The low word of Scale High data is on Math34		R
6284	The high word of Scale High data is on Math34		R
6285	The low word of Scale High data is on Math35		R
6286	The high word of Scale High data is on Math35		R
6287	The low word of Scale High data is on Math36		R
6288	The high word of Scale High data is on Math36		R
6289	The low word of Scale High data is on Math37		R
6290	The high word of Scale High data is on Math37		R
6291	The low word of Scale High data is on Math38		R
6292	The high word of Scale High data is on Math38		R
6293	The low word of Scale High data is on Math39		R
6294	The high word of Scale High data is on Math39		R
6295	The low word of Scale High data is on Math40		R
6296	The high word of Scale High data is on Math40		R
6297	The low word of Scale High data is on Math41		R
6298	The high word of Scale High data is on Math41		R
6299	The low word of Scale High data is on Math42		R
6300	The high word of Scale High data is on Math42		R
6301	The low word of Scale High data is on Math43		R
6302	The high word of Scale High data is on Math43		R
6303	The low word of Scale High data is on Math44		R
6304	The high word of Scale High data is on Math44		R
6305	The low word of Scale High data is on Math45		R
6306	The high word of Scale High data is on Math45		R
6307	The low word of Scale High data is on Math46		R
6308	The high word of Scale High data is on Math46		R
6309	The low word of Scale High data is on Math47		R
6310	The high word of Scale High data is on Math47		R
6311	The low word of Scale High data is on Math48		R
6312	The high word of Scale High data is on Math48		R
6313	The low word of Scale High data is on Math49		R
6314	The high word of Scale High data is on Math49		R
6315	The low word of Scale High data is on Math50		R
6316	The high word of Scale High data is on Math50		R
6317	The low word of Scale High data is on Math51		R
6318	The high word of Scale High data is on Math51		R
6319	The low word of Scale High data is on Math52		R
6320	The high word of Scale High data is on Math52		R
6321	The low word of Scale High data is on Math53		R
6322	The high word of Scale High data is on Math53		R
6323	The low word of Scale High data is on Math54		R
6324	The high word of Scale High data is on Math54		R
6325	The low word of Scale High data is on Math55		R
6326	The high word of Scale High data is on Math55		R
6327	The low word of Scale High data is on Math56		R
6328	The high word of Scale High data is on Math56		R
6329	The low word of Scale High data is on Math57		R
6330	The high word of Scale High data is on Math57		R
6331	The low word of Scale High data is on Math58		R
6332	The high word of Scale High data is on Math58		R
6333	The low word of Scale High data is on Math59		R
6334	The high word of Scale High data is on Math59		R

Modbus Address	Register Name	Note	Access
6335	The low word of Scale High data is on Math60		R
6336	The high word of Scale High data is on Math60		R
6337	The low word of Scale High data is on Ext1		R
6338	The high word of Scale High data is on Ext1		R
6339	The low word of Scale High data is on Ext2		R
6340	The high word of Scale High data is on Ext2		R
6341	The low word of Scale High data is on Ext3		R
6342	The high word of Scale High data is on Ext3		R
6343	The low word of Scale High data is on Ext4		R
6344	The high word of Scale High data is on Ext4		R
6345	The low word of Scale High data is on Ext5		R
6346	The high word of Scale High data is on Ext5		R
6347	The low word of Scale High data is on Ext6		R
6348	The high word of Scale High data is on Ext6		R
6349	The low word of Scale High data is on Ext7		R
6350	The high word of Scale High data is on Ext7		R
6351	The low word of Scale High data is on Ext8		R
6352	The high word of Scale High data is on Ext8		R
6353	The low word of Scale High data is on Ext9		R
6354	The high word of Scale High data is on Ext9		R
6355	The low word of Scale High data is on Ext10		R
6356	The high word of Scale High data is on Ext10		R
6357	The low word of Scale High data is on Ext11		R
6358	The high word of Scale High data is on Ext11		R
6359	The low word of Scale High data is on Ext12		R
6360	The high word of Scale High data is on Ext12		R
6361	The low word of Scale High data is on Ext13		R
6362	The high word of Scale High data is on Ext13		R
6363	The low word of Scale High data is on Ext14		R
6364	The high word of Scale High data is on Ext14		R
6365	The low word of Scale High data is on Ext15		R
6366	The high word of Scale High data is on Ext15		R
6367	The low word of Scale High data is on Ext16		R
6368	The high word of Scale High data is on Ext16		R
6369	The low word of Scale High data is on Ext17		R
6370	The high word of Scale High data is on Ext17		R
6371	The low word of Scale High data is on Ext18		R
6372	The high word of Scale High data is on Ext18		R
6373	The low word of Scale High data is on Ext19		R
6374	The high word of Scale High data is on Ext19		R
6375	The low word of Scale High data is on Ext20		R
6376	The high word of Scale High data is on Ext20		R
6377	The low word of Scale High data is on Ext21		R
6378	The high word of Scale High data is on Ext21		R
6379	The low word of Scale High data is on Ext22		R
6380	The high word of Scale High data is on Ext22		R
6381	The low word of Scale High data is on Ext23		R
6382	The high word of Scale High data is on Ext23		R
6383	The low word of Scale High data is on Ext24		R
6384	The high word of Scale High data is on Ext24		R
6385	The low word of Scale High data is on Ext25		R
6386	The high word of Scale High data is on Ext25		R
6387	The low word of Scale High data is on Ext26		R
6388	The high word of Scale High data is on Ext26		R
6389	The low word of Scale High data is on Ext27		R
6390	The high word of Scale High data is on Ext27		R

Modbus Address	Register Name	Note	Access
6391	The low word of Scale High data is on Ext28		R
6392	The high word of Scale High data is on Ext28		R
6393	The low word of Scale High data is on Ext29		R
6394	The high word of Scale High data is on Ext29		R
6395	The low word of Scale High data is on Ext30		R
6396	The high word of Scale High data is on Ext30		R
6397	The low word of Scale High data is on Ext31		R
6398	The high word of Scale High data is on Ext31		R
6399	The low word of Scale High data is on Ext32		R
6400	The high word of Scale High data is on Ext32		R
6401	The low word of Scale High data is on Ext33		R
6402	The high word of Scale High data is on Ext33		R
6403	The low word of Scale High data is on Ext34		R
6404	The high word of Scale High data is on Ext34		R
6405	The low word of Scale High data is on Ext35		R
6406	The high word of Scale High data is on Ext35		R
6407	The low word of Scale High data is on Ext36		R
6408	The high word of Scale High data is on Ext36		R
6409	The low word of Scale High data is on Ext37		R
6410	The high word of Scale High data is on Ext37		R
6411	The low word of Scale High data is on Ext38		R
6412	The high word of Scale High data is on Ext38		R
6413	The low word of Scale High data is on Ext39		R
6414	The high word of Scale High data is on Ext39		R
6415	The low word of Scale High data is on Ext40		R
6416	The high word of Scale High data is on Ext40		R
6417	The low word of Scale High data is on Ext41		R
6418	The high word of Scale High data is on Ext41		R
6419	The low word of Scale High data is on Ext42		R
6420	The high word of Scale High data is on Ext42		R
6421	The low word of Scale High data is on Ext43		R
6422	The high word of Scale High data is on Ext43		R
6423	The low word of Scale High data is on Ext44		R
6424	The high word of Scale High data is on Ext44		R
6425	The low word of Scale High data is on Ext45		R
6426	The high word of Scale High data is on Ext45		R
6427	The low word of Scale High data is on Ext46		R
6428	The high word of Scale High data is on Ext46		R
6429	The low word of Scale High data is on Ext47		R
6430	The high word of Scale High data is on Ext47		R
6431	The low word of Scale High data is on Ext48		R
6432	The high word of Scale High data is on Ext48		R
6433	The low word of Scale High data is on Ext49		R
6434	The high word of Scale High data is on Ext49		R
6435	The low word of Scale High data is on Ext50		R
6436	The high word of Scale High data is on Ext50		R
6437	The low word of Scale High data is on Ext51		R
6438	The high word of Scale High data is on Ext51		R
6439	The low word of Scale High data is on Ext52		R
6440	The high word of Scale High data is on Ext52		R
6441	The low word of Scale High data is on Ext53		R
6442	The high word of Scale High data is on Ext53		R
6443	The low word of Scale High data is on Ext54		R
6444	The high word of Scale High data is on Ext54		R
6445	The low word of Scale High data is on Ext55		R
6446	The high word of Scale High data is on Ext55		R

Modbus Address	Register Name	Note	Access
6447	The low word of Scale High data is on Ext56		R
6448	The high word of Scale High data is on Ext56		R
6449	The low word of Scale High data is on Ext57		R
6450	The high word of Scale High data is on Ext57		R
6451	The low word of Scale High data is on Ext58		R
6452	The high word of Scale High data is on Ext58		R
6453	The low word of Scale High data is on Ext59		R
6454	The high word of Scale High data is on Ext59		R
6455	The low word of Scale High data is on Ext60		R
6456	The high word of Scale High data is on Ext60		R
6457	The low word of Scale High data is on Ext61		R
6458	The high word of Scale High data is on Ext61		R
6459	The low word of Scale High data is on Ext62		R
6460	The high word of Scale High data is on Ext62		R
6461	The low word of Scale High data is on Ext63		R
6462	The high word of Scale High data is on Ext63		R
6463	The low word of Scale High data is on Ext64		R
6464	The high word of Scale High data is on Ext64		R
6465	The low word of Scale High data is on Ext65		R
6466	The high word of Scale High data is on Ext65		R
6467	The low word of Scale High data is on Ext66		R
6468	The high word of Scale High data is on Ext66		R
6469	The low word of Scale High data is on Ext67		R
6470	The high word of Scale High data is on Ext67		R
6471	The low word of Scale High data is on Ext68		R
6472	The high word of Scale High data is on Ext68		R
6473	The low word of Scale High data is on Ext69		R
6474	The high word of Scale High data is on Ext69		R
6475	The low word of Scale High data is on Ext70		R
6476	The high word of Scale High data is on Ext70		R
6477	The low word of Scale High data is on Ext71		R
6478	The high word of Scale High data is on Ext71		R
6479	The low word of Scale High data is on Ext72		R
6480	The high word of Scale High data is on Ext72		R
6481	The low word of Scale High data is on Ext73		R
6482	The high word of Scale High data is on Ext73		R
6483	The low word of Scale High data is on Ext74		R
6484	The high word of Scale High data is on Ext74		R
6485	The low word of Scale High data is on Ext75		R
6486	The high word of Scale High data is on Ext75		R
6487	The low word of Scale High data is on Ext76		R
6488	The high word of Scale High data is on Ext76		R
6489	The low word of Scale High data is on Ext77		R
6490	The high word of Scale High data is on Ext77		R
6491	The low word of Scale High data is on Ext78		R
6492	The high word of Scale High data is on Ext78		R
6493	The low word of Scale High data is on Ext79		R
6494	The high word of Scale High data is on Ext79		R
6495	The low word of Scale High data is on Ext80		R
6496	The high word of Scale High data is on Ext80		R
6497	The low word of Scale High data is on Ext81		R
6498	The high word of Scale High data is on Ext81		R
6499	The low word of Scale High data is on Ext82		R
6500	The high word of Scale High data is on Ext82		R
6501	The low word of Scale High data is on Ext83		R
6502	The high word of Scale High data is on Ext83		R

Modbus Address	Register Name	Note	Access
6503	The low word of Scale High data is on Ext84		R
6504	The high word of Scale High data is on Ext84		R
6505	The low word of Scale High data is on Ext85		R
6506	The high word of Scale High data is on Ext85		R
6507	The low word of Scale High data is on Ext86		R
6508	The high word of Scale High data is on Ext86		R
6509	The low word of Scale High data is on Ext87		R
6510	The high word of Scale High data is on Ext87		R
6511	The low word of Scale High data is on Ext88		R
6512	The high word of Scale High data is on Ext88		R
6513	The low word of Scale High data is on Ext89		R
6514	The high word of Scale High data is on Ext89		R
6515	The low word of Scale High data is on Ext90		R
6516	The high word of Scale High data is on Ext90		R
6517	The low word of Scale High data is on Ext91		R
6518	The high word of Scale High data is on Ext91		R
6519	The low word of Scale High data is on Ext92		R
6520	The high word of Scale High data is on Ext92		R
6521	The low word of Scale High data is on Ext93		R
6522	The high word of Scale High data is on Ext93		R
6523	The low word of Scale High data is on Ext94		R
6524	The high word of Scale High data is on Ext94		R
6525	The low word of Scale High data is on Ext95		R
6526	The high word of Scale High data is on Ext95		R
6527	The low word of Scale High data is on Ext96		R
6528	The high word of Scale High data is on Ext96		R

Note:

The Scale Low / High can be modified only when the input type is Linear.

8.1.3.3.1 How to calculate Modbus Scale Low / High

- ❖ Get Scale low and Scale High from Recorder AI Configuration
- ❖ Calculate Δ Scale Range,
 Δ Scale Range = Scale High - Scale Low
- ❖ Calculate Modbus Range
Modbus Δ Scale Range = Δ Scale Range * 1.2
- ❖ Calculate Modbus Scale Low = Scale Low - (Modbus Δ Scale Range - Δ Scale Range)
- ❖ Calculate Modbus Scale High = Scale High + (Modbus Δ Scale Range - Δ Scale Range)
- ❖ Convert the Modbus Scale Low / High value to DWord value using the below formulae.

DP	DP Value
0	1
1	10
2	100
3	1000
4	10000
5	100000

For example:

Scale Low is 500, Scale High is 1000

Δ Scale Range = Scale High - Scale Low = 1000 - 500 = 500

Modbus Δ Scale Range = Δ Scale Range * 1.2 = 500 * 1.2 = 600

Modbus Scale Low = Scale Low - (Modbus Δ Scale Range - Δ Scale Range)
= 500 - (600 - 500) = 500 - 100 = 400

Modbus Scale High = Scale High + (Modbus Δ Scale Range - Δ Scale Range)
= 1000 + (600 - 500) = 1000 + 100 = 1100

Convert the Modbus Scale Low value to DWord value:

$((400 * \text{DP Value}) - (-2147483648)) / (2147483647 - (-2147483648)) * 4294967295$

The DP Value is 1 when the DP is 0 =>

$((400 - (-2147483648)) / 4294967295) * 4294967295$

= $(2147484048 / 4294967295) * 4294967295$

= 2147484048

Convert the Modbus Scale High value to DWord value:

$((1100 * \text{DP Value}) - (-2147483648)) / (2147483647 - (-2147483648)) * 294967295$

The DP Value is 1 when the DP is 0 =>

$(1100 - (-2147483648)) / (2147483647 - (-2147483648)) * 4294967295$

= $(2147484748 / 4294967295) * 4294967295$

= 2147484748

Convert DWord value to Real Scale Value:

Modbus Scale High = $((\text{DWord Value} - 0) * 4294967295) / 4294967295 + (-2147483648)) / \text{DP Value}$

= $((2147484748 - 0) * 4294967295) / 4294967295 + (-2147483648)) / 1$

= $((2147484748 * 4294967295) / 4294967295 - 2147483648) / 1$

= 2147484748 - 2147483648

= 1100

Modbus Scale Low = $((\text{DWord Value} - 0) * 4294967295) / 4294967295 + (-2147483648)) / \text{DP Value}$

= $((2147484048 - 0) * 4294967295) / 4294967295 + (-2147483648)) / 1$

= $((2147484048 * 4294967295) / 4294967295 - 2147483648) / 1$

= 2147484048 - 2147483648

= 400

8.1.3.3.2 How to calculate Scale Low / High

Let's say Scale Low is 'A' and Scale High is 'B'.

Modbus Scale Low = Scale Low - (Modbus Δ Scale Range - Δ Scale Range)

= Scale Low - (Scale High - Scale Low) * 1.2 - (Scale High - Scale Low)

= A - (B - A) * 1.2 - (B - A)

= A - (1.2B - 1.2A - B + A)

= A - (0.2B - 0.2A)

Modbus Scale Low = 1.2A - 0.2B-----Equation 1

Modbus Scale High = Scale High + (Modbus Δ Scale Range - Δ Scale Range)

= Scale High + ((Scale High - Scale Low) * 1.2 - (Scale High - Scale Low))

= B + ((B - A) * 1.2 - (B - A))

= B + (1.2B - 1.2A - B + A)

= B + (0.2B - 0.2A)

Modbus Scale High = 1.2B - 0.2A-----Equation 2

Multiply by 6

6 * Modbus Scale High = 7.2B - 1.2A

1.2A = 7.2B - (6 * Modbus Scale High) -----Equation 3

Replace 1.2A in Equation 1 with the value in Equation 3

Modbus Scale Low = 1.2A - 0.2B

Modbus Scale Low = 7.2B - (6 * Modbus Scale High) - 0.2B

Modbus Scale Low = 7B - (6 * Modbus Scale High)

Modbus Scale Low + (6 * Modbus Scale High) = 7B

(Modbus Scale Low+(6*Modbus Scale High))/7 =B-----Equation 4

Replace B Value in Equation 2 to find A Value

Modbus Scale High = 1.2B - 0.2A

Modbus Scale High = 1.2 * ((Modbus Scale Low + (6 * Modbus Scale High)) / 7) - 0.2A

0.2A = 1.2 * ((Modbus Scale Low + (6 * Modbus Scale High)) / 7) - Modbus Scale High

A = (1.2 * ((Modbus Scale Low + (6 * Modbus Scale High)) / 7) - Modbus Scale High) / 0.2---Equation 5

8.1.3.4 Others (Word Type)

Modbus Address	Register Name	Note	Access
11001	PR Version		R
11002	Plus NO.	ø	R

Note:

Value	Description
0	Standard
1	Plus 1
2	Plus 2
3	Plus 3

8.2 Modbus Communication

8.2.1 Read Input Registers (Function 0x04)

The function code is used to read from 1 to 120 contiguous input registers in remote device.

Query

The query message specifies the starting register and quantity of registers to be read. Registers are addressed starting at zero: register 1 – 16 are addressed as 0 – 15.

Here is an example of a request to read register 0 (register type is Input Register, address is 1) from slave device 1:

Field Name	RTU example (Hex)
Slave Address	01
Function	04
Starting Address Hi	00
Starting Address Lo	00
Quantity of Registers Hi	00
Quantity of Registers Lo	01
Error Check Lo	31
Error Check Hi	CA
Total Bytes	8

Response

The register data in the response message are packed as two bytes per registers, with the binary contents right justified within each byte. For each register, the first byte contains the high order bits and the second contains the low order bits.

The response is return when the data is completely assembled. Here is an example of a response to the query on the opposite page:

Field Name	RTU example (Hex)
Slave Address	01
Function	04

Field Name	RTU example (Hex)
Byte Count	02
Data Hi	00
Data Lo	0A
Error Check Lo	39
Error Check Hi	37
Total Bytes	7

8.2.2 Preset (Write) Multiple Registers (Function 0x10)

The function code is used to write a block of contiguous registers (1 to 120 registers) in remote device.

Query

The query message specified the register references to be preset. Registers are addressed starting at zero: register 1 is addressed as 0. The requested preset values are specified in the query data field. Data is packed as two bytes per register.

Here is an example of a request to preset two registers starting at 40001 to 00 0A and 01 02 hex in slave device 1:

Field Name	RTU example (Hex)
Slave Address	01
Function	10
Starting Address Hi	00
Starting Address Lo	00
Quantity of Registers Hi	00
Quantity of Registers Lo	02
Byte Count	04
Data Hi	00
Data Lo	0A
Data Hi	01
Data Lo	02
Error Check Lo	53
Error Check Hi	FC
Total Bytes	13

Response

The normal response returns the slave address, function code, starting address and quantity of registers preset. Here is an example of a response to the query shown above:

Field Name	RTU example (Hex)
Slave Address	01
Function	10
Starting Address Hi	00
Starting Address Lo	00
Quantity of Registers Hi	00
Quantity of Registers Lo	02
Error Check Lo	41
Error Check Hi	C8
Total Bytes	13

```

0x00, 0xC1, 0x81, 0x40, 0x00, 0xC1, 0x81, 0x40, 0x01, 0xC0, 0x80, 0x41, 0x00, 0xC1, 0x81,
0x40, 0x01, 0xC0, 0x80, 0x41, 0x01, 0xC0, 0x80, 0x41, 0x00, 0xC1, 0x81, 0x40, 0x01, 0xC0,
0x80, 0x41, 0x00, 0xC1, 0x81, 0x40, 0x00, 0xC1, 0x81, 0x40, 0x01, 0xC0, 0x80, 0x41, 0x01,
0xC0, 0x80, 0x41, 0x00, 0xC1, 0x81, 0x40, 0x00, 0xC1, 0x81, 0x40, 0x01, 0xC0, 0x80, 0x41,
0x00, 0xC1, 0x81, 0x40, 0x01, 0xC0, 0x80, 0x41, 0x01, 0xC0, 0x80, 0x41, 0x00, 0xC1, 0x81,
0x40
};

```

Low-Order Byte Table

/* Table of CRC values for low-order byte */

```

static char auchCRCLo[] = {
0x00, 0xC0, 0xC1, 0x01, 0xC3, 0x03, 0x02, 0xC2, 0xC6, 0x06, 0x07, 0xC7, 0x05, 0xC5, 0xC4,
0x04, 0xCC, 0x0C, 0x0D, 0xCD, 0x0F, 0xCF, 0xCE, 0x0E, 0x0A, 0xCA, 0xCB, 0x0B, 0xC9, 0x09,
0x08, 0xC8, 0xD8, 0x18, 0x19, 0xD9, 0x1B, 0xDB, 0xDA, 0x1A, 0x1E, 0xDE, 0xDF, 0x1F, 0xDD,
0x1D, 0x1C, 0xDC, 0x14, 0xD4, 0xD5, 0x15, 0xD7, 0x17, 0x16, 0xD6, 0xD2, 0x12, 0x13, 0xD3,
0x11, 0xD1, 0xD0, 0x10, 0xF0, 0x30, 0x31, 0xF1, 0x33, 0xF3, 0xF2, 0x32, 0x36, 0xF6, 0xF7,
0x37, 0xF5, 0x35, 0x34, 0xF4, 0x3C, 0xFC, 0xFD, 0x3D, 0xFF, 0x3F, 0x3E, 0xFE, 0xFA, 0x3A,
0x3B, 0xFB, 0x39, 0xF9, 0xF8, 0x38, 0x28, 0xE8, 0xE9, 0x29, 0xEB, 0x2B, 0x2A, 0xEA, 0xEE,
0x2E, 0x2F, 0xEF, 0x2D, 0xED, 0xEC, 0x2C, 0xE4, 0x24, 0x25, 0xE5, 0x27, 0xE7, 0xE6, 0x26,
0x22, 0xE2, 0xE3, 0x23, 0xE1, 0x21, 0x20, 0xE0, 0xA0, 0x60, 0x61, 0xA1, 0x63, 0xA3, 0xA2,
0x62, 0x66, 0xA6, 0xA7, 0x67, 0xA5, 0x65, 0x64, 0xA4, 0x6C, 0xAC, 0xAD, 0x6D, 0xAF, 0x6F,
0x6E, 0xAE, 0xAA, 0x6A, 0x6B, 0xAB, 0x69, 0xA9, 0xA8, 0x68, 0x78, 0xB8, 0xB9, 0x79, 0xBB,
0x7B, 0x7A, 0xBA, 0xBE, 0x7E, 0x7F, 0xBF, 0x7D, 0xBD, 0xBC, 0x7C, 0xB4, 0x74, 0x75, 0xB5,
0x77, 0xB7, 0xB6, 0x76, 0x72, 0xB2, 0xB3, 0x73, 0xB1, 0x71, 0x70, 0xB0, 0x50, 0x90, 0x91,
0x51, 0x93, 0x53, 0x52, 0x92, 0x96, 0x56, 0x57, 0x97, 0x55, 0x95, 0x94, 0x54, 0x9C, 0x5C,
0x5D, 0x9D, 0x5F, 0x9F, 0x9E, 0x5E, 0x5A, 0x9A, 0x9B, 0x5B, 0x99, 0x59, 0x58, 0x98, 0x88,
0x48, 0x49, 0x89, 0x4B, 0x8B, 0x8A, 0x4A, 0x4E, 0x8E, 0x8F, 0x4F, 0x8D, 0x4D, 0x4C, 0x8C,
0x44, 0x84, 0x85, 0x45, 0x87, 0x47, 0x46, 0x86, 0x82, 0x42, 0x43, 0x83, 0x41, 0x81, 0x80,
0x40
};

```

8.3.2 Read Data Function

```

/*****/
// Parameter:
// Addr -> Slave ID
// StReg -> Starting Register Address
// RegQuantities -> Register Quantities
// MbsBuf -> Receive Data Buffer
/*****/
bool ReadData(unsigned char Addr, unsigned short StReg,
unsigned short RegQuantities, unsigned char* MbsBuf)
{
unsigned char msg[8];
unsigned char Func = 0x04;
unsigned short Crc;

msg[0] = Addr;
msg[1] = Func;
msg[2] = HIBYTE(StReg);
msg[3] = LOBYTE(StReg);
msg[4] = HIBYTE(RegQuantities);
msg[5] = LOBYTE(RegQuantities);

```

```

    Crc = CRC16(msg,6);
    msg[6] = HIBYTE(Crc);
    msg[7] = LOBYTE(Crc);
    int snd = 8; /* byte number of buffer msg */
    int rcv = (5+(RegQuantities*2));
    /* Send snd bytes content of msg to COMM port */
    /* Receive rcv bytes of response from COMM port to MbsBuf */
    if (receiving data length is same as rcv)
    return true;
    else
    return false;
}

```

8.3.3 Convert Data Function

```

/*****/
// Parameter:
// ValueRangeLo -> Minimum value of the value range
// ValueRangeHi -> Maximum value of the value range
// ScaleLo -> Minimum value of the scale value
// ScaleHi -> Maximum value of the scale value
// RegData -> Current register data from remote device
/*****/
double ConvertData(double ValueRangeLo,
double ValueRangeHi,
double ScaleLo,
double ScaleHi,
double RegData)
{
    double ConvertValue;
    ConvertValue = (((RegData*(ScaleHi - ScaleLo))/(ValueRangeHi - ValueRangeLo))+ ScaleLo);
    return ConvertValue;
}

```

8.3.4 Read AI Function'

```

bool ReadAIData(void)
{
    unsigned char MsgBuf[40];
    unsigned char Addr = 1; /* Slave Id */
    unsigned short StartRegAdd = 2;
    unsigned short RegQuantities = 5;
    int ScaleLo, ScaleHi,
    ValueRangeLo, ValueRangeHi,
    AiData;
    unsigned short RegData;

    // Read register data from remote device
    ReadData(Addr, StartRegAdd, RegQuantities, MsgBuf);

    // Step 1: Parsing data for AI1
    RegData = MAKEWORD(MsgBuf[4], MsgBuf[3]);
}

```

```

// Step 2: Set value range
//Because AI data type was set as 2 bytes, the value range would be
// showing between -32768 to 32767
ValueRangeLo = -32768;
ValueRangeHi = 32767;

// Step 3: Set value range for scale
//The default of Sensor type in AI1 is set as 『 Thermocouple K Type 』 .
// Scale low value is showing “-120”, scale high value is showing “1000”
//Please refer to AIconfiguration for Modbus Scale
ScaleLo = -120;
ScaleHi = 1000;

// Step 4: Execute converted function
AiData = (int)ConvertData(ValueRangeLo,
ValueRangeHi,
ScaleLo,
ScaleHi,
RegData);
// Step 5: Repeat Step 1 to Step 4 for getting another AI data
}

```

8.3.5 Read Math Function¹

```

bool ReadMathData(void)
{
    unsigned char MsgBuf[120];
    unsigned char i, j;
    unsigned char Addr = 1; /* Slave Id */
    unsigned short StartRegAdd = 201;
    unsigned short RegQuantities = (10*2); // Math data is float type, so each Math value take two registers
    double ScaleLo, ScaleHi, ValueRangeLo, ValueRangeHi;
    double RegData, MathData;

// Read register data from remote device
ReadData(Addr, StartRegAdd, RegQuantities, MsgBuf);

// Step 1: Set value range
//The default of Math data type was set as 4 bytes, the value range will be showing between0 to
//4294967295
ValueRangeLo = 0;
ValueRangeHi = 4294967295;

// Step 2: Set value range for scale
// When the property of “Transformation” in scale was set as disable, the range will be showing
//-2147483648 to 2147483647
// If the property of “Transformation” in Scale was set as “Value” or “Math Channel”, please refer to
//Appendix D

ScaleLo = -2147483648;

```

```
ScaleHi = 2147483647;
```

```
// Step 3: Please refer to the decimal value for the conversion of each
```

```
Math
```

```
    switch(decimal value)
    {
        case 1:
            ScaleLo = ScaleLo / 10;
            ScaleHi = ScaleHi / 10;

            break;
        case 2:
            ScaleLo = ScaleLo / 100;
            ScaleHi = ScaleHi / 100;
            break;
        case 3:
            ScaleLo = ScaleLo / 1000;
            ScaleHi = ScaleHi / 1000;

            break;
        case 4:
            ScaleLo = ScaleLo / 10000;
            ScaleHi = ScaleHi / 10000;

            break;
        case 5:
            ScaleLo = ScaleLo / 100000;
            ScaleHi = ScaleHi / 100000;

            break;
        default:
            break;
    }
```

```
// Step 4: Parsing data for Math1
```

```
RegData = (UINT)MAKELONG(MAKEWORD(MsgBuf[j+1],
MsgBuf[j]),
MAKELONG(MsgBuf[j+3],
MsgBuf[j+2]));
```

```
// Step 5: Execute converted function
```

```
MathData = ConvertData(ValueRangeLo,
ValueRangeHi,
ScaleLo,
ScaleHi,
RegData);
```

```
// Step 6: Repeat Step 1 to Step 5 for getting another data of Math
```

```
}
```

8.3.6 Read DI Function'

```
bool ReadDIData(void)
{
```



```

        unsigned char MsgBuf[96];
        unsigned char Addr = 1; /* Slave Id */
        unsigned short StartRegAdd = 50;
        unsigned short RegQuantities = 5;
        bool DiData;

        // Read register data from remote device
        ReadData(Addr, StartRegAdd, RegQuantities, MsgBuf);

        // Step 1: Parsing data for DI1
        DiData = (bool)MAKEWORD(MsgBuf[4], MsgBuf[3]);

        // Step 2: Repeat Step 1 for getting another DI data
    }

```

8.3.7 Read AO Function1

```

bool ReadAOData(void)
{
    unsigned char MsgBuf[48];
    unsigned char Addr = 1; /* Slave Id */
    unsigned short StartRegAdd = 601;
    unsigned short RegQuantities = 5;
    unsigned short RegData;
    float AoData;

    // Read register data from remote device
    ReadData(Addr, StartRegAdd, RegQuantities, MsgBuf);

    // Because the AO expression is specific, so we need using specific// expression to convert the value
    //as following:
    // Step 1: Parsing data for AO1
    RegData = MAKEWORD(MsgBuf[4], MsgBuf[3]);

    // Step2: To do converted expression for AO1
    AoData = ((RegData * 65.535)/65535)-32.768;

    // Step 3: Repeat Step 1 to Step 2 for getting another AO data
}

```

8.3.8 Read DO Function1

```

bool ReadDOData(void)
{
    unsigned char MsgBuf[48];
    unsigned char Addr = 1; /* Slave Id */
    unsigned short StartRegAdd = 74;
    unsigned short RegQuantities = 5;
    bool DoData;

    // Read register data from remote device

```

```

ReadData(Addr, StartRegAdd, RegQuantities, MsgBuf);

// Step 1: Parsing data for DO1
DiData = (bool)MAKEWORD(MsgBuf[4], MsgBuf[3]);

// Step 2: Repeat Step 1 for getting another DO data
}

```

8.3.9 Read External Function1

```

bool ReadExtData(void)
{
    unsigned char MsgBuf[128];
    unsigned char Addr = 1; /* Slave Id */
    unsigned short StartRegAdd = 401;
    unsigned short RegQuantities = 20;
    unsigned short ExtData;
    // Read register data from remote device
    ReadData(Addr, StartRegAdd, RegQuantities, MsgBuf);

    // Step 1: Parsing data for Ext1
    DiData = MAKEWORD(MsgBuf[4], MsgBuf[3]);

    // Step 2: Repeat Step 1 for getting another Ext data
}

```

Note:

*1: Above sample code is according to the PPS-2000 setting, if user need changing the MsgBuf size and RegQuantities value from PPS-1000 or PPS-3000, please refer to the user manual.

Because the Input Register Ext data is same like Holding Register Ext data, so the data type of the ExtData must according to the setting of real case, if the data type of ExtData is 4 bytes, please refer to “ReadMathData” function in Step 1, Step 2, Step 4 and Step 5 to convert data type of customer Requirement (Such as: Int32 or UInt32 or float data type).

```

}

```

8.4 Appendix

8.4.1 Modbus RTU Slave / TCP Server Register data type table

Field Name	Data Size	Data Type	Note
AI	2 Bytes	WORD	Little Endian
Math	4 Bytes	UINT32	Little Endian
DI	2 Bytes	WORD	Little Endian
AO	2 Bytes	WORD	Little Endian
DO	2 Bytes	WORD	Little Endian
External	2 Bytes / 4 Bytes	WORD / DWORD	Little Endian

8.4.2 Inquire AI range

The Modbus scale range for each AI channel is available in the channel configuration page as shown below.

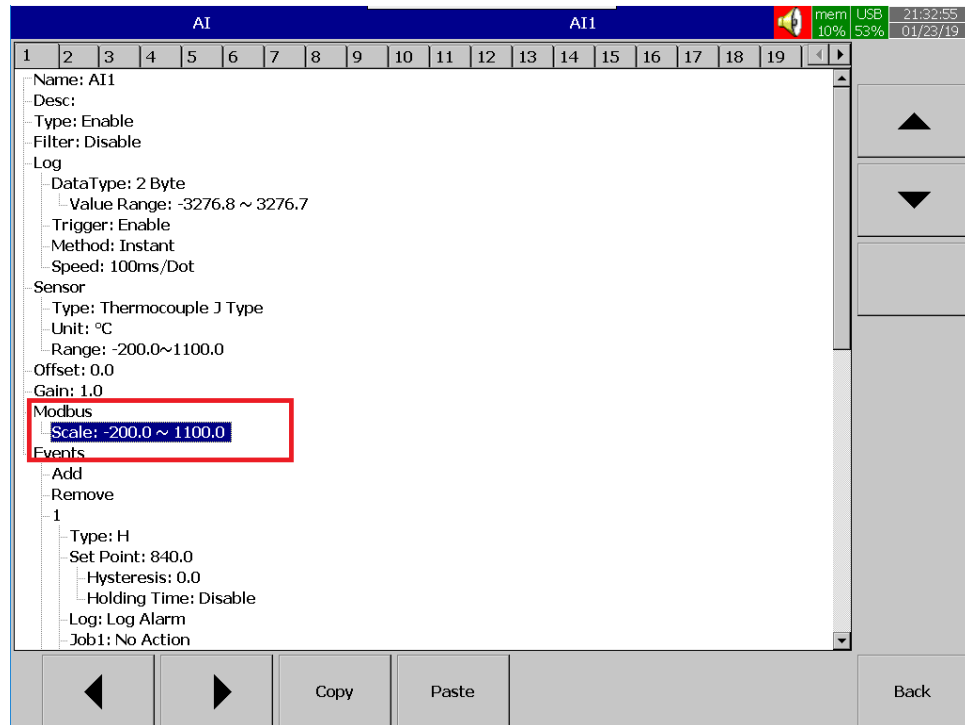

8.4.3 AI Conversion Example

The below example shows the procedure to convert the raw value received in Modbus register to engineering value. If the floating point type mapped register used to read then the user don't need to do any conversion. The register itself has the engineering value. If the integer type register is used then the user need to do the conversion as per the below to convert the raw value to engineering value. The Modbus low scale and high scale value is available on the channel configuration page as shown on the above picture.

$$\text{AI Value} = (\text{Data Register Value} * (\text{AI High Scale} - \text{AI low scale}) / 65535) + \text{AI low scale}$$

For example the AI range is set to -200 to 1100. If the register value is 32000 then the actual AI value is as below.

$$\begin{aligned} \text{AI Value} &= (\text{Data Register Value} * (\text{AI High Scale} - \text{AI low scale}) / 65535) + \text{AI low scale} \\ &= (32000 * (1100 - (-200)) / 65535) + (-200) \\ &= (32000 * 1300) / 65535 - 200 \\ &= 634.78 - 200 \\ &= 434.78 \end{aligned}$$

8.4.4 Math Converion Sample

The below example shows the procedure to convert the raw value received in Modbus register to engineering value. If the floating point type mapped register used to read then the user don't need to do any conversion. The register itself has the engineering value. If the integer type register is used then the user needs to do the conversion as per the below to convert the raw value to engineering value.

8.4.4.1 Transformation Disable

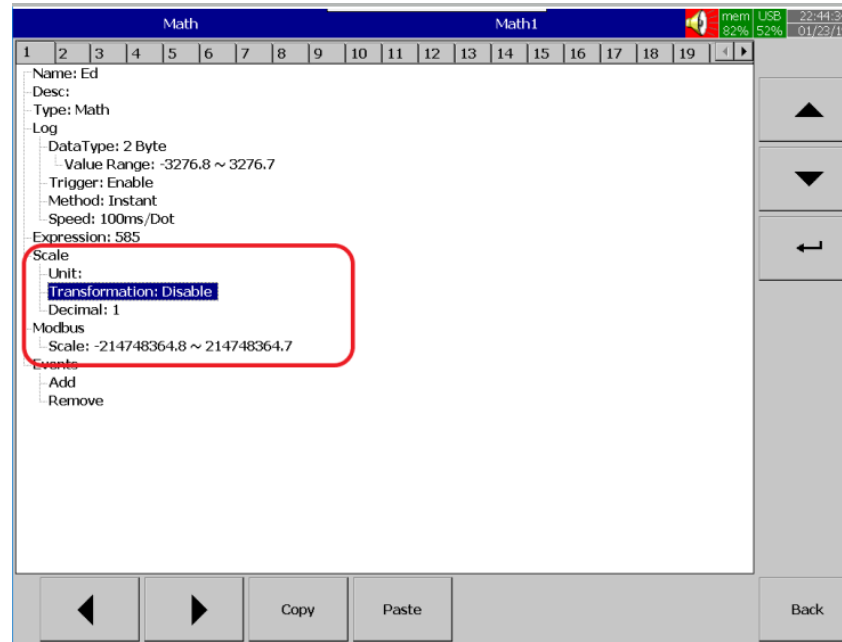

If the transformation is set to disable and the decimal point is '0' then the value received on the register don't need any conversion. If the decimal value is set as "1", then the value must to be divided by 10 to match with the value in Math of PR. If the decimal value is set as "2", then the value must to be divided by 100 to match with the value in Math of PR. If the decimal value is set as "3" then the value must be divided by 1000 to match the value in Math of PR. If the decimal value is set as "4" then the value must be divided by 10000 to match the value in Math of PR. If the decimal value is set as "5" then the value must be divided by 100000 to match the value in Math of PR.

8.4.4.2 Transformation as value

If the transformation is set to value and table is configured with transformation table entries then the below formulae to be used to convert the raw value of Dword register to actual math channel value.

$$\text{Math value} = (((\text{Register value} * (\text{ScaleHi} - \text{ScaleLo})) / 4294967295) + \text{ScaleLo})$$

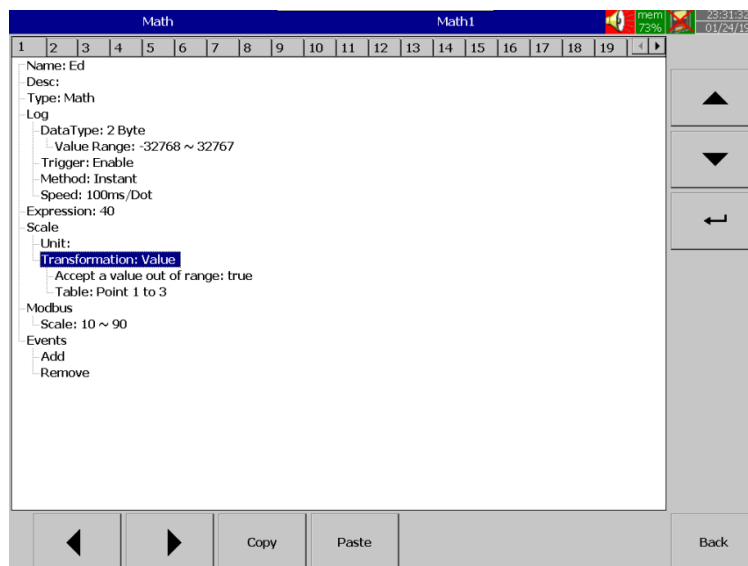

The scale low and scale hi of the math channel can be referenced from transformation table output values. For example, the transformation table configured as below.

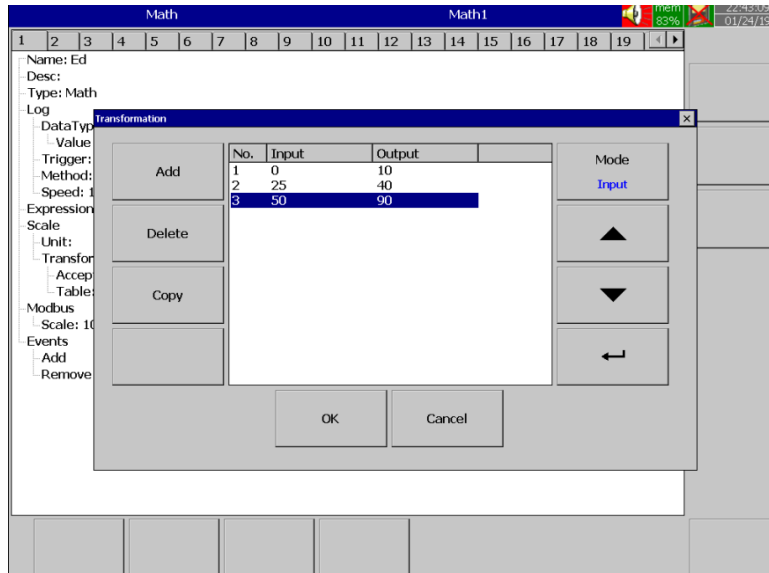

The high scale of this channel is 90 and low scale of this channel is 10. The value of math channel is 68. The value at modbus register is 3092376452. The register value can be converted to math channel actual value by using the below conversion.

$$\begin{aligned}
 \text{Math value} &= (((\text{Register value} * (\text{ScaleHi} - \text{ScaleLo})) / 4294967295) + \text{ScaleLo}) \\
 &= ((3092376452 * (90 - 10)) / 4294967295) + 10 \\
 &= ((3092376452 * 80) / 4294967295) + 10 \\
 &= 57.6 + 10 \\
 &= 58 + 10 \text{ (rounded to nearest integer)} \\
 &= 68
 \end{aligned}$$

8.4.4.3 Transformation as Math Channel

If the transformation is set to value and the decimal point is '0' then the value received on the register don't need any conversion. If the decimal value is set as "1", then the value must to be divided by 10 to match with the value in Math of PR. If the decimal value is set as "2", then the value must to be divided by 100 to match with the value in Math of PR. If the decimal value is set as "3" then the value must be divided by 1000 to match the value in Math of PR. If the decimal value is set as "4" then the value must be divided by 10000 to match the value in Math of PR. If the decimal value is set as "5" then the value must be divided by 100000 to match the value in Math of PR.

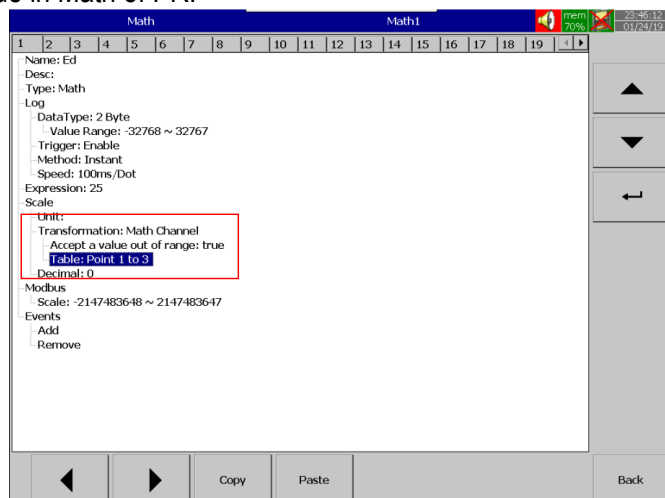

8.4.5 AO Conversion Example

The AO Value data contains the raw data which can be converted to actual AO value using the below conversion.

$$\text{AO value} = (((\text{Register value} * 65.535) / 65535) - 32.768)$$

For example, the AO value received in the register is 52411 then the actual value is calculated as below.

$$\begin{aligned} \text{AO value} &= (((52411 * 65.535) / 65535) - 32.768) \\ &= 3434754.885 / 65535 - 32.768 \\ &= 19.643 \end{aligned}$$

8.4.6 External Channel Conversion for AI channel

Configure the data type as 2 Byte.

Change the Actual low and Actual high of external channel as similar to AI Channel.

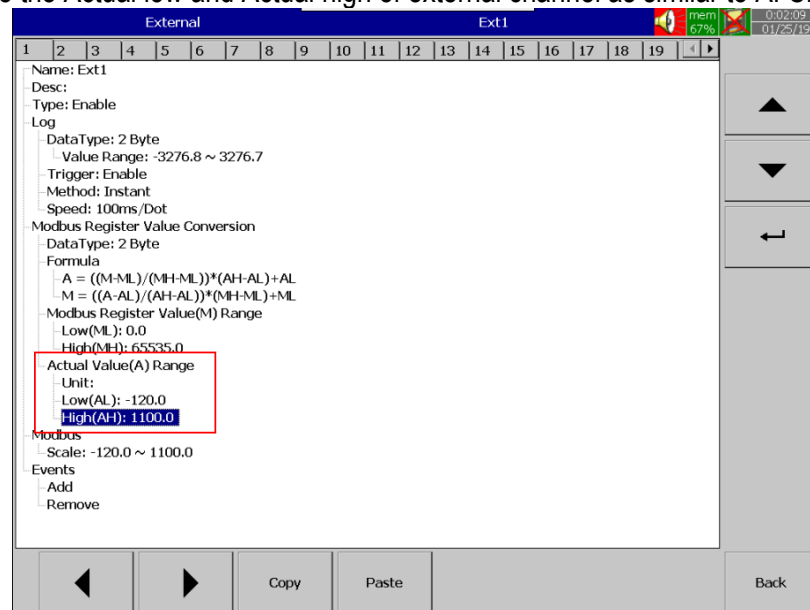

8.4.7 External Channel Conversion for DI and DO channel

The DI and DO channels don't need any any conversion to read in external channel. The channel data type needs to be configured as 2 Byte.

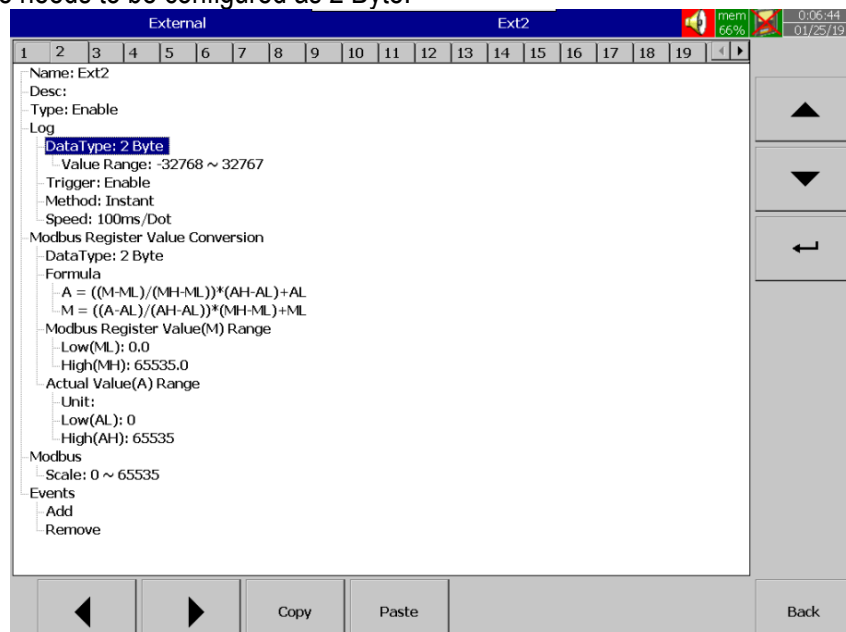

8.4.8 External Channel Conversion for AO channel

Configure the channel as 2 Byte.

Configure the external channel Actual Value Low as -32.768 and Actual Value High as 32.767.

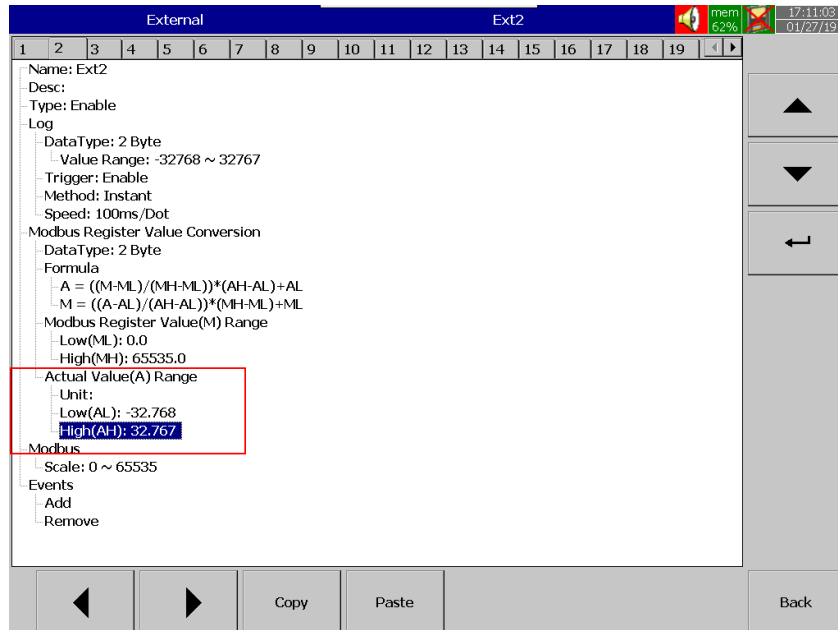

8.4.9 External Channel Conversion for Math channel

Configure the channel as 4 Byte.

Configure the Actual Value Low and high as below depends on decimal value of Math channel configuration.

If the decimal is 0, Actual Value Low as -2147483648.0 and Actual value High as 2147483647.0.

If the decimal is 1, Actual Value Low as -214748364.8 and Actual value High as 214748364.7.

If the decimal is 2, Actual Value Low as -21474836.48 and Actual value High as 21474836.47.

If the decimal is 3, Actual Value Low as -2147483.648 and Actual value High as 2147483.647.

If the decimal is 4, Actual Value Low as -214748.3648 and Actual value High as 214748.3647.

If the decimal is 5, Actual Value Low as -21474.83648 and Actual value High as 21474.83647.

External Ext1 17:23:50 01/27/19

1	2	3	4	5	6	7	8	9	10	11	12	13	14	15	16	17	18	19
---	---	---	---	---	---	---	---	---	----	----	----	----	----	----	----	----	----	----

Name: Ext1
Desc:
Type: Enable
Log
 DataType: 4 Byte
 Value Range: -3.4E+38 ~ 3.4E+38
 Trigger: Enable
 Method: Instant
 Speed: 100ms/Dot
Modbus Register Value Conversion
 DataType: 4 Byte
 Formula
 A = $((M-ML)/(MH-ML))*(AH-AL)+AL$
 M = $((A-AL)/(AH-AL))*(MH-ML)+ML$
 Modbus Register Value(M) Range
 Low(ML): 0.0
 High(MH): 4294967295.0
 Actual Value(A) Range
 Unit:
 Low(AL): -21474.83648
 High(AH): 21474.83648
Modbus
 Scale: -21474.83648 ~ 21474.83647
Events
 Add
 Remove

Navigation buttons: Up, Down, Left, Right, Copy, Paste, Back

Custom Manufacturer Since 1972

ELECTRIC HEATING ELEMENTS • TEMPERATURE CONTROLS • SENSORS • PROCESS HEATING SYSTEMS

HEAT THINGS UP!

With Thousands of Design Variations
We Make Everything You Need.

Band Heaters	Cartridge Heaters
Cast-In Heaters	Coil & Cable Heaters
Radiant Heaters	Strip Heaters
Flexible Heaters	Tubular Heaters
Process Heaters	Instrumentation
Temperature Control	Temperature Sensors



607 N. Central Avenue Wood Dale, IL 60191-1452 USA
P: 630-350-2252 Toll Free: 800-323-6859
F: 630-350-0232 E: info@tempco.com
www.tempco.com