

TEMPCO®

USER MANUAL

TEC-4500 and TEC-9500

Auto-Tune PID

Ramp & Soak Temperature Controllers



Warning Symbol

This symbol calls attention to an operating procedure, practice, or the like which, if not correctly performed or adhered to, could result in personal injury or damage to or destruction of part or all of the product and system. Do not proceed beyond a warning symbol until the indicated conditions are fully understood and met.

Using the Manual

- Installers Read Chapter 1, 2
- System Designer Read All Chapters
- Expert User Read Page 15, 16

CONTENTS

	Page Number
Chapter 1 Overview	
1-1 General	1
1-2 Hardware Code	3
1-3 Programming Port	4
1-4 Keys and Displays	5
1-5 Menu Overview	6
1-6 Parameter Descriptions	8
Chapter 2 Installation	
2-1 Unpacking	12
2-2 Mounting	12
2-3 Wiring Precautions	13
2-4 Power Wiring	14
2-5 Sensor Input Wiring	14
2-6 Control Output Wiring	14
2-7 Alarm Output Wiring	16
2-8 Event Input Wiring	16
2-9 Retransmission Output Wiring	16
2-10 Data Communication	17
Chapter 3 Programming	
3-1 Lockout	18
3-2 Signal Input	18
3-3 Event Input	19
3-4 Control Outputs	20
3-5 Alarms	23
3-6 Configuring Home Page	25
3-7 User Calibration	25
3-8 Digital Filter	26
3-9 Failure Transfer	26
3-10 Auto-tuning	27
3-11 Manual Tuning	27
3-12 Manual Mode	28
3-13 Data Communication	28
3-14 Retransmission	28
3-15 Output Scaling	39

NOTE:

It is strongly recommended that a process should incorporate a **LIMIT CONTROL** like **TEC-910** which will shut down the equipment at a preset process condition in order to preclude possible damage to products or system.

Information in this user's manual is subject to change without notice.

Copyright © 2021, Tempco Electric Heater Corporation, all rights reserved. No part of this publication may be reproduced, transmitted, transcribed or stored in a retrieval system, or translated into any language in any form by any means without the written permission of Tempco Electric Heater Corporation.

CONTENTS

	Page Number
Chapter 4 Profile Operation	
4-1 What is set point profile	30
4-2 Segment connection	30
4-3 Profile Modes	31
4-4 Running, holding and aborting a profile	31
4-5 Viewing and modifying profile progress	32
4-6 Start	32
4-7 Holdback	32
4-8 Power failure	33
4-9 Configuring the profile	34
4-10 Viewing and creating a profile	35
Controller settings to program a profile	37
4-11 Event Outputs and PID Selection	39
Chapter 5 Applications	40
Chapter 6 Specifications	42
Chapter 7 Modbus Comm.	44
7-1 Functions Supported	44
7-2 Exception Responses	45
7-3 Parameter Table	45
7-4 Number System	45
7-5 Communication Example	46
Appendix	
A-1 Error Codes	48
Returns	49

FIGURES & TABLES**Page
Number**

Figure 1.1 Fuzzy Control Advantage	1
Figure 1.2 Programming Port Overview	4
Figure 1.3 Front Panel Description	5
Figure 1.4 Program Code Display	5
Figure 2.1 Mounting Dimensions	12
Figure 2.2 Lead Termination for TEC-4500	13
Figure 2.3 Lead Termination for TEC-9500	13
Figure 2.4 Rear Terminal Connection for TEC-4500	13
Figure 2.5 Rear Terminal Connection for TEC-9500	13
Figure 2.6 Power Supply Connections	14
Figure 2.7 Sensor Input Wiring	14
Figure 2.8 Output 1 Relay or Triac (SSR) to Drive Load	14
Figure 2.9 Output 1 Relay or Triac (SSR) to Drive Contactor	14
Figure 2.10 Output 1 Pulsed Voltage to Drive SSR	14
Figure 2.11 Output 1 Linear Current	14
Figure 2.12 Output 1 Linear Voltage	14
Figure 2.13 Output 2 Relay or Triac (SSR) to Drive Load	15
Figure 2.14 Output 2 Relay or Triac (SSR) to Drive Contactor	15
Figure 2.15. Output 2 Pulsed Voltage to Drive SSR	15
Figure 2.16 Output 2 Linear Current	15
Figure 2.17 Output 2 Linear Voltage	15
Figure 2.18 Alarm / Event output wiring	16
Figure 2.19 Alarm Output to Drive Contactor	16
Figure 2.20 Event Input wiring	16
Figure 2.21 Retransmission Wiring	16
Figure 2.22 RS-485 Wiring	17
Figure 2.23 RS-232 Wiring	17
Figure 2.24 Configuration of RS-232 Cable	17
Figure 3.1 Conversion Curve for Linear Type Process Value	18
Figure 3.2 Heat Only ON-OFF Control	21
Figure 3.3 Heat - Cool Control	21
Figure 3.4 Process high alarm 1 operation	23
Figure 3.5 Process low alarm 1 operation	23
Figure 3.6 Deviation high alarm 1 operation	23
Figure 3.7 Deviation low alarm 1 operation	23
Figure 3.8 Deviation band alarm 1 operation	23
Figure 3.9 Two point user calibration	25
Figure 3.10 Filter Characteristics	26
Figure 3.11 Effects of PID Adjustment	27
Figure 3.12 Output scaling function	29

FIGURES & TABLES**Page
Number**

Figure 4.1 Set point profile	30
Figure 4.2 Holdback operation	32
Figure 4.3 Recovery from profile at dwell segment	33
Figure 4.4 Recovery from profile at ramp segment	33
Figure 4.5 Recovery from PV at dwell segment	33
Figure 4.6 Recovery from PV at ramp segment	33
Figure 4.7 Profiling curve example	36
Figure 5.1 A Heat Treatment Oven	40
Figure 5.2 Temperature profile of the Heat Treatment Oven	41
Table 3.1 Password operation	18
Table 3.2 Heat-Cool control configuration value	20
Table 3.3 Alarm mode description	24
Table 3.4 PID Adjustment Guide	27
Table 4.1 Segment types	30
Table 4.2 Profile Modes	31
Table 4.3 Parameters that follow segment type	35
Table 7.1 Exception Code Table	45
Table 7.2 Number Conversion Table	45
Table A.1 Error Codes and Corrective Actions	48

Chapter 1 Overview

1-1 General

Tempco's TEC-4500 and TEC-9500 Fuzzy Logic plus PID microprocessor-based Ramp and soak controllers incorporate two bright easy to read 4-digit LED displays, indicating process value and set point value. The process value (PV) display is always the top digital display. The setpoint (SV) display is always the bottom display. Fuzzy Logic technology enables a process to reach a predetermined set point in the shortest time with a minimum of overshoot during power-up or external load disturbance.

TEC-9500 is a 1/16 DIN size panel mount Ramp and Soak controller. It can also be used for rail mounting by adding a rail mount kit. TEC-4500 is a 1/4 DIN size panel mount Ramp and Soak controller. These units are powered by an 11-26 or 90-250 VDC/VAC 50/60 Hz supply, incorporating a 2 amp control relay output as standard. The second output can be used as a cooling control or an alarm. Both outputs can select triac, 5V logic output, linear current, or linear voltage to drive an external device. The units are fully programmable for PT100 RTD and thermocouple types J, K, T, E, B, R, S, N, L, C, and P with no need to modify the unit. The input signal is digitized by using an 18-bit A to D converter. Its fast sampling rate allows the unit to control fast processes.

There are more functions than heating and cooling. Control could be configured for the controller outputs, these include: up to three alarm outputs, up to three event outputs, and/or up to two analog retransmission outputs.

Flexible Configuration of Program

Up to 64 segments can be defined for a profile. Each segment can be configured as a ramp or a dwell (soak) segment or defining a repeat number of cycles at arbitrary location within the profile and finally terminated by an end segment. The user can edit a currently running profile.

Maximum Capacity of Program

There are at most 9 profiles that can be defined and 288 segments total available for all profiles. The profiles are divide into three kinds of length. The short length profile contains 16 segments, the medium length profile contains 32 segments, while the long length profile contains 64 segments at most.

Event Input

The event input feature allows the user to select one of eight functions: enter profile run mode, enter profile hold mode, abort profile mode, enter manual mode, perform failure transfer, enter off mode, advance to the next segment, and select second set of PID values.

Programmable event outputs

Up to three relays are configurable for event outputs and the state of each output can be defined for each segment and end of profile.

Analog retransmission

Output 5 and output 4 (TEC-4500 only) can be equipped with an analog output module. The output can be configured for transmitting the process value as well as set point value.

Digital communications RS-485 or RS-232 are available as an additional option. These options allow the units to be integrated with supervisory control systems and software.

A programming port is available for automatic configuration, calibration, and testing without the need to access the keys on the front panel.

By using proprietary Fuzzy modified PID technology, the control loop will minimize overshoot and undershoot in a short time. The following diagram is a comparison of results with and without Fuzzy technology.

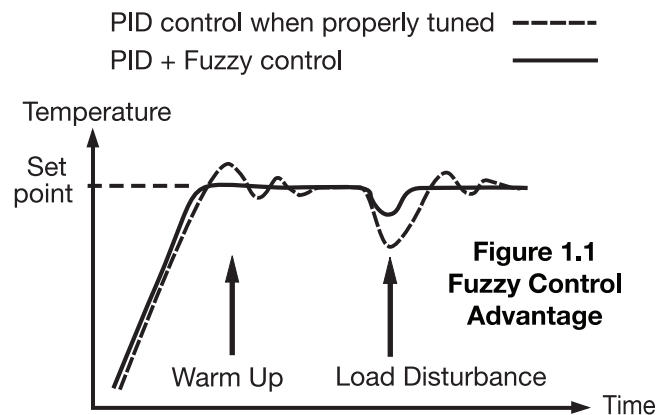

The ramp and soak series can be configured as a single set point controller (static mode) or a ramp and dwell profiling controller (profile mode). The profile mode feature allows the user to program up to 9 profiles of up to 64 segments each depending on the profile number (ramp, dwell, jump or end). The total segments available for the controller is 288 segments.

High accuracy

The ramp and soak series is manufactured with custom designed ASIC (Application Specific Integrated Circuit) technology which contains an 18-bit A to D converter for high resolution measurement (true 0.1°F resolution for thermocouple and PT100) and a 15-bit D to A converter for linear current or voltage control output. The ASIC technology provides improved operating performance, low cost, enhanced reliability and higher density.

Fast sampling rate

The sampling rate of the input A to D converter is 5 times/second. The fast sampling rate allows this series to control fast processes.

Fuzzy control

The function of Fuzzy control is to adjust PID parameters from time to time in order to make manipulation of the output value more flexible and adaptive to various processes. The result is to enable a process to reach a predetermined set point in the shortest time with the minimum of overshoot and undershoot during power-up or external load disturbance.

Digital communication

The controllers can be equipped with an optional RS-485 or RS-232 interface card to provide digital communication. By using twisted pair wires, up to 247 units can be connected together via an RS-485 interface to a host computer.

Programming port

A programming port can be used to connect the controller to a PC for quick configuration.

Auto-tune

The auto-tune function allows the user to simplify initial setup for a new system. An advanced algorithm is used to obtain an optimal set of control parameters for the process. It can be applied either as the process is warming up (cold start) or while the process is in a steady state (warm start).

Lockout protection

Depending on security requirements, a password setting is available to prevent unwanted changes.

Bumpless transfer

Bumpless transfer allows the controller to continue to control if the sensor breaks by using its previous output value. Hence, the process can be controlled temporarily as if the sensor is normal and constant.

Digital filter

A first order low pass filter with a programmable time constant is used to improve the stability of the process value. This is particularly useful in certain applications where the process value is too unstable to be read.

SEL function

The controllers have the flexibility to allow the user to select those parameters which are most significant to him and put these parameters in the front of the display sequence. Up to eight parameters can be selected at one time to allow the user to build his own display sequence.

1-2 Hardware Code

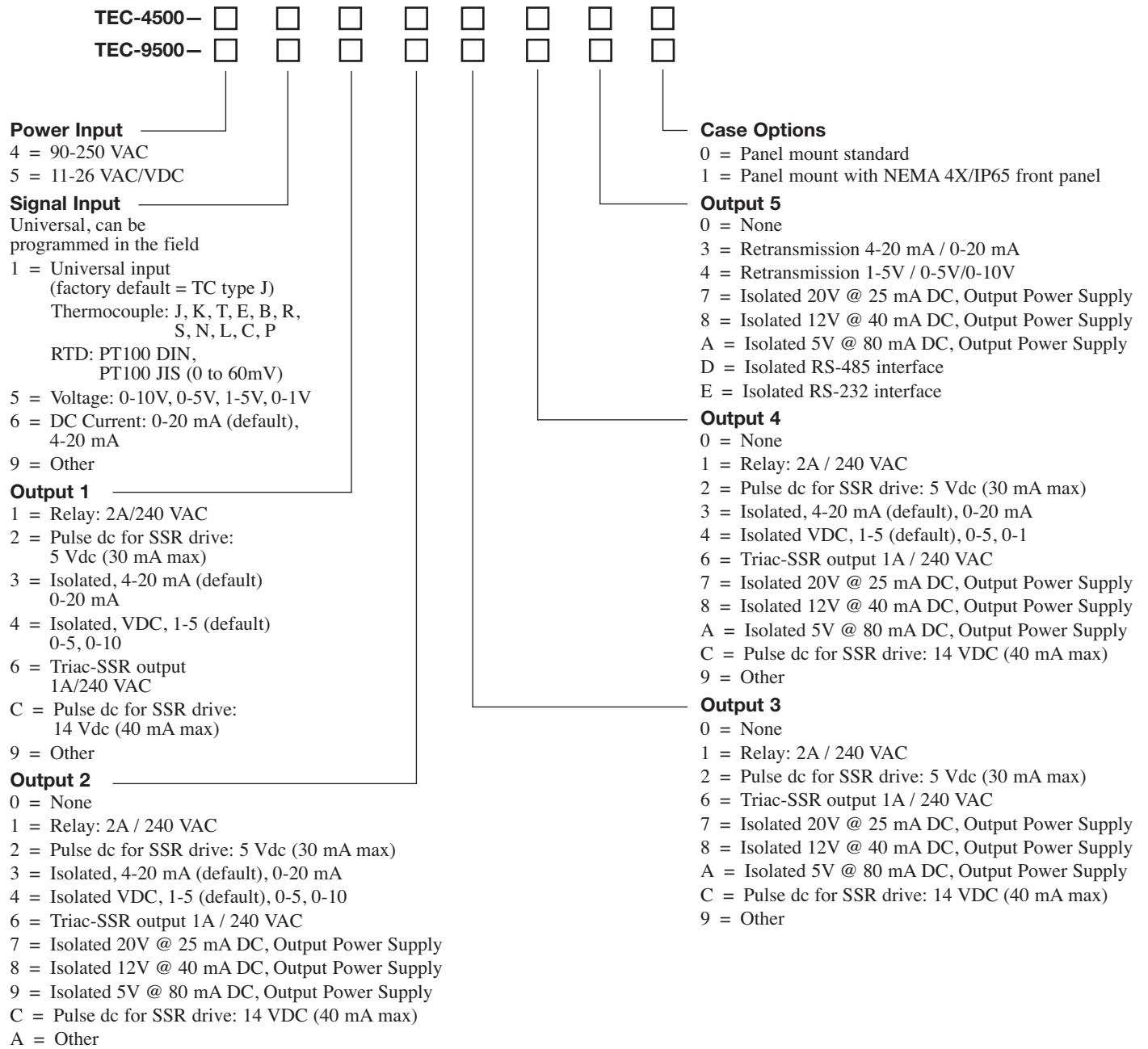

Data Communication Accessories:

TEC99001 Smart Network Adapter for third party SCADA software which converts 255 channels of RS-485 or RS-422 to RS-232 Network.

TEC99003 Smart Network Adapter for connecting the programming port to the RS-232 PC serial port. Allows downloading and reading of configuration information directly from a personal computer.

TEC99030 "Tempco Config Set" PC software for use with TEC99003 Smart Network Adapter. (*can be downloaded at no charge from www.tempco.com*)

Minimum System Requirements:
Microsoft Windows 2000, 98, 95, NT4.0
Pentium 200 MHz or faster
32 MB RAM (64 MB recommended)
Hard disk space: 2 MB

TEC99011 Connects the controller to the TEC99003 Smart Network Adapter.

Accessories

TEC99014 = RS-232 Interface Cable (2M)

TEC99011 = Programming Port Cable (requires TEC99001 programming adapter)

1-3 Programming Port

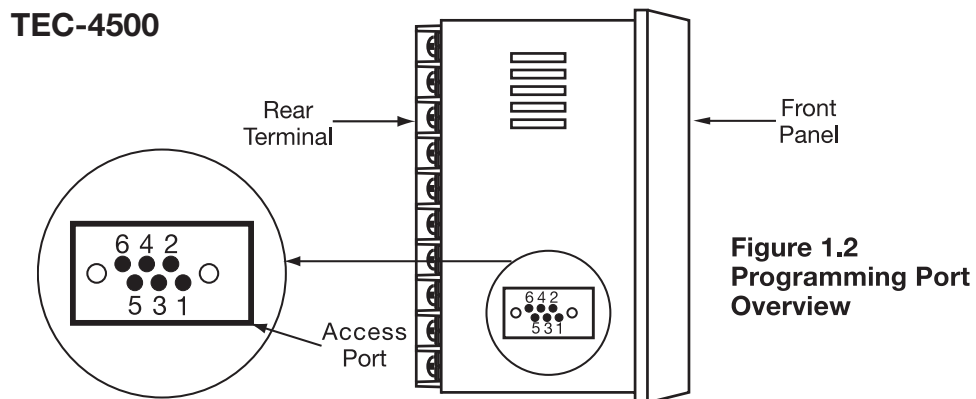

A special connector can be used to connect the programming port to a PC for automatic configuration.

The programming port is used for off-line automatic setup and testing procedures only. Do not attempt to make any connections to these pins when the unit is under power.

1-4 Keys and Displays

KEYPAD OPERATION

SCROLL KEY:

This key is used to select a parameter to be viewed or adjusted.

UP KEY:

This key is used to increase the value of the selected parameter.

DOWN KEY:

This key is used to decrease the value of the selected parameter.

RESET KEY:

Press both keys to:

1. Revert the display to show the process value.
2. Reset the latching alarm, once the alarm condition is removed.
3. Stop the manual control mode, auto-tuning mode, and off mode, then enter the static mode.
4. Clear the message of communication error, holdback time out error, and the auto-tuning error.

ENTER KEY: Press and hold for 5 seconds to:

1. Run selected mode.
2. Execute calibration procedure for the low point and high point calibration.
3. Press and release to change pages (note key operation flowchart on the following page)

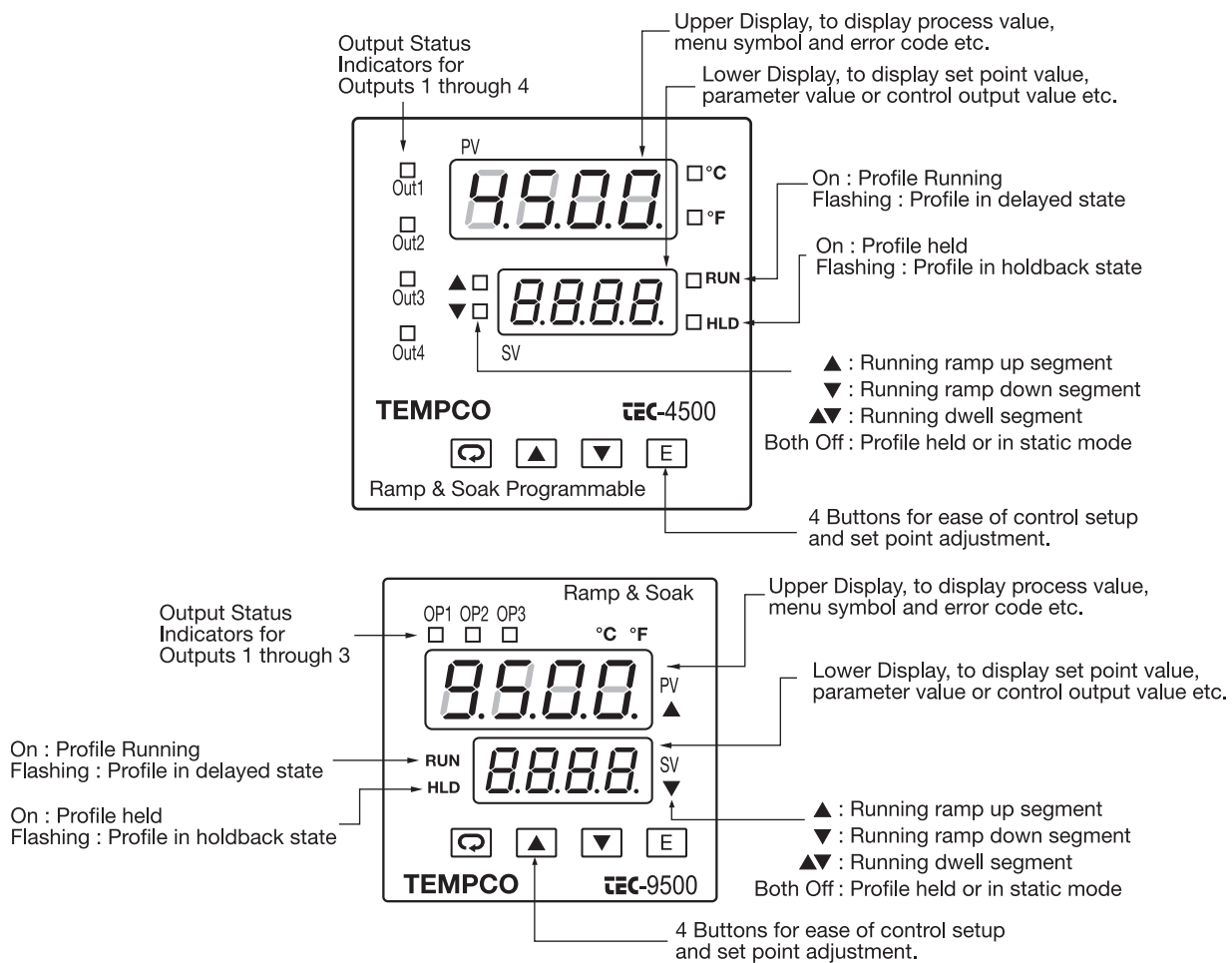

Figure 1.3 Front Panel Description

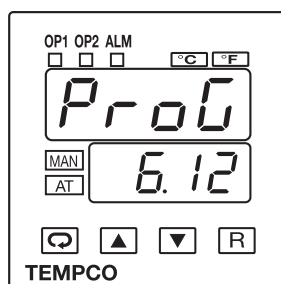

Figure 1.4 Program Code Display

The unit will display program code of the product for 2.5 seconds during power up.

The display shows program number 37 with program version 12 for TEC-4500.

The display shows program number 38 with program version 12 for TEC-9500.

1-5 Menu Overview

1-5 Key Operation Flowchart

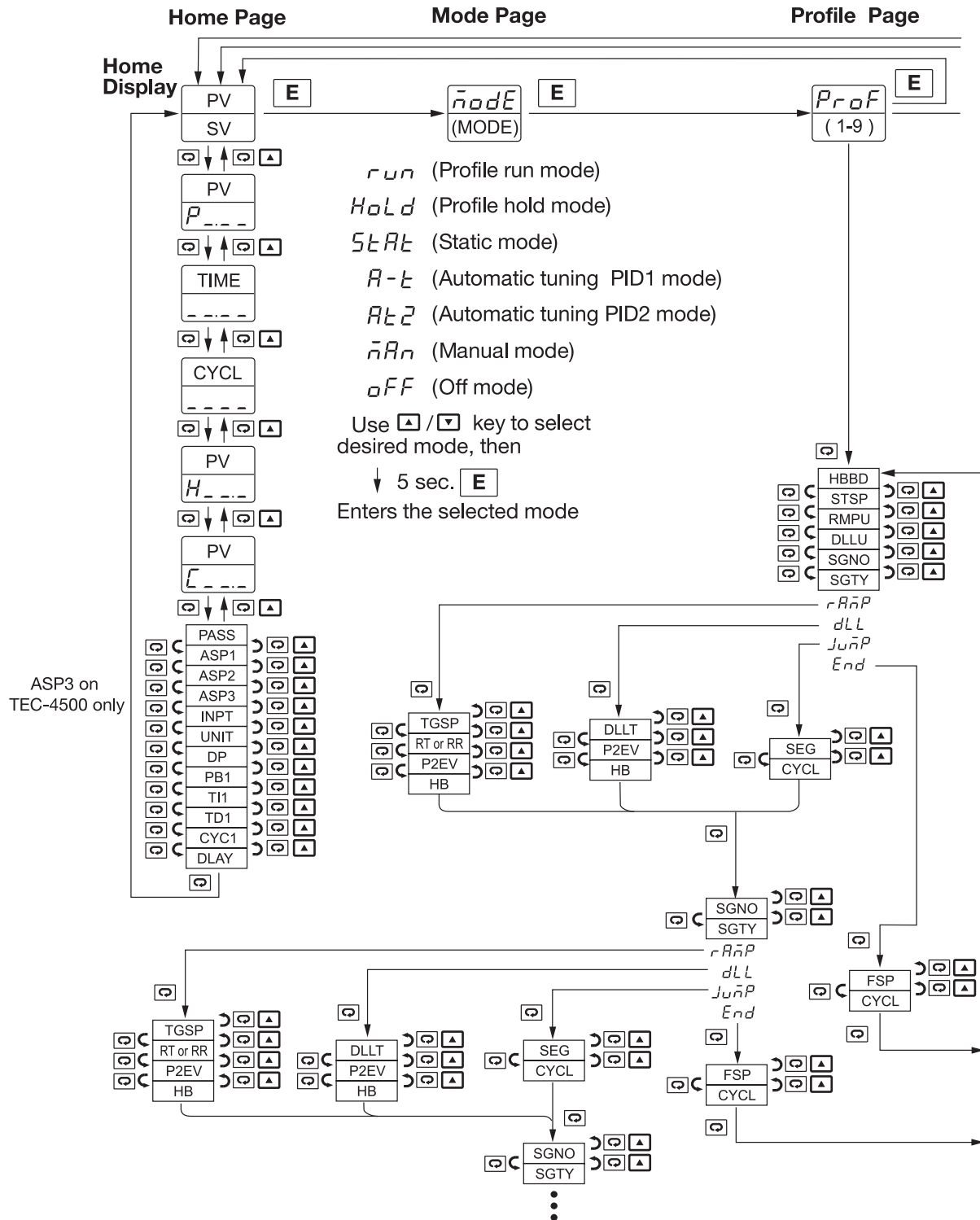

For Ramp & Soak Profile Settings refer to Chapter 4 page 31.

1-5 Key Operation Flowchart (continued)

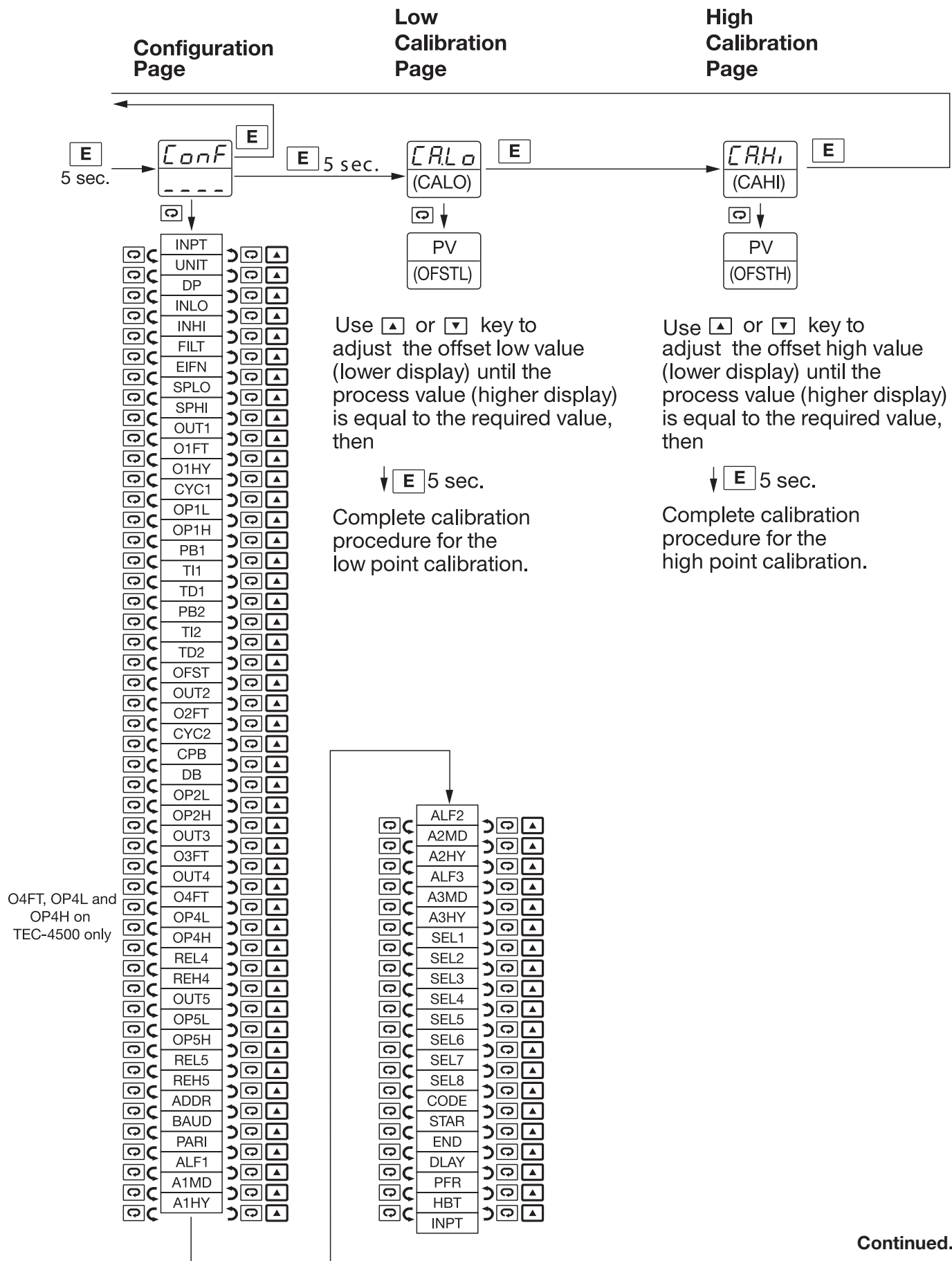

Continued...

Parameter Descriptions — Page 2 of 4

Register Address	Parameter Notation	Parameter Description	Range	Default Value	Data Type
34	O2FT o2Ft	Output 2 failure transfer status	Select BPLS (bumpless transfer) or 0.0 ~ 100.0 % to continue output 2 control function if the sensor input fails, or select OFF (0) or ON (1) for alarm or event output.	0	R/W
35	CYC2 CYC2	Output 2 cycle time	Low: 0.1 High: 90.0 sec.	18.0	R/W
36	CPB CPb	Cooling proportional band value	Low: 50 High: 300 %	100	R/W
37	DB db	Heating-cooling dead band (negative value= overlap)	Low: -36.0 High: 36.0 %	0	R/W
38	OP2L oP2L	Low limit value for output 2	Low: 0 High: 100.0 %	0	R/W
39	OP2H oP2H	High limit value for output 2	Low: 0 High: 120.0 %	100.0	R/W
40		Reserved			
41		Reserved			
42	OUT3 oUt3	Output 3 function	0 nonE : No function 1 ALn2 : Alarm 2 output 2 rAL2 : Reverse alarm 2 output 3 EYn2 : Event 2 output 4 dCP5 : DC power supply output	3	R/W
43	O3FT o3Ft	Output 3 failure transfer status	0 oFF : Output 3 OFF if sensor input fails 1 on : Output 3 ON if sensor input fails	0	R/W
44	OUT4 oUt4	Output 4 function (for TEC-4500 only) (page 29)	0 nonE : No function 1 ALn3 : Alarm 3 output 2 rAL3 : Reverse alarm 3 output 3 EYn3 : Event 3 output 4 rEPY : Retransmit process value 5 rESP : Retransmit set point value	3	R/W
45	O4FT o4Ft	Output 4 failure transfer status (for TEC-4500 only)	0 oFF : Output 4 OFF as unit fails 1 on : Output 4 ON as unit fails	0	R/W
46	OP4L oP4L	Low limit value for output 4 (for TEC-4500 only)	Low: 0 High: 100.0 %	0	R/W
47	OP4H oP4H	High limit value for output 4 (for TEC-4500 only)	Low: 0 High: 120.0 %	100.0	R/W
48	REL4 rEL4	Retransmission low scale value for output4 (for TEC-4500 only)	Low: -32768 High:32767	0.0°C (32.0°F)	R/W
49	REH4 rEH4	Retransmission high scale value for output4 (for TEC-4500 only)	Low: -32768 High:32767	100.0°C (212.0°F)	R/W
50		Reserved			
51	OUT5 oUt5	Output 5 function (page 29)	0 nonE : No function 1 Coññ : Communication port 2 rEPY : Retransmit process value 3 rESP : Retransmit set point value 4 dCP5 : DC power supply output	0	R/W
52	OP5L oP5L	Low limit value for output 5	Low: 0 High: 100.0 %	0	R/W
53	OP5H oP5H	High limit value for output 5	Low: 0 High: 120.0 %	100.0	R/W
54	REL5 rEL5	Retransmission low scale value for output 5	Low: -32768 High:32767	0.0°C (32.0°F)	R/W
55	REH5 rEH5	Retransmission high scale value for output 5	Low: -32768 High:32767	100.0°C (212.0°F)	R/W
56	ADDR Addr	Address assignment of digital communication	Low: 1 High: 247	1	R/W

Register Address	Parameter Notation	Parameter Description	Range	Default Value	Data Type
57	BAUD bRud	Baud rate of digital communication	0 24 : 2.4 Kbits/s baud rate 1 48 : 4.8 Kbits/s baud rate 2 96 : 9.6 Kbits/s baud rate 3 144 : 14.4 Kbits/s baud rate 4 192 : 19.2 Kbits/s baud rate 5 288 : 28.8 Kbits/s baud rate 6 384 : 38.4 Kbits/s baud rate	2	R/W
58	PARI PRr,	Parity bit of digital communication	0 EYEn : Even parity 1 odd : Odd parity 2 nonE : No parity bit	0	R/W
59	ALF1 ALF1	Alarm 1 function (page 24)	0 PУH, : Process high alarm 1 PУLo : Process low alarm 2 dEH, : Deviation high alarm 3 dELo : Deviation low alarm 4 dbHL : Deviation band high/low alarm 5 EndP : End of profile alarm 6 Hold : Hold mode alarm 7 StARt : Static mode alarm	2	R/W
60	A1MD RlnD	Alarm 1 operation mode	0 norñ : Normal alarm action 1 LcH : Latching alarm action 2 Hold : Hold alarm action 3 LcHo : Latching & hold alarm action	0	R/W
61	A1HY RlHY	Hysteresis control for alarm 1	Low: 0.1 High: 50.0°C (90.0°F)	0.1°C (0.2°F)	R/W
62	ALF2 ALF2	Alarm 2 function	0 PУH, : Process high alarm 1 PУLo : Process low alarm 2 dEH, : Deviation high alarm 3 dELo : Deviation low alarm 4 dbHL : Deviation band high/low alarm 5 EndP : End of profile alarm 6 Hold : Hold mode alarm 7 StARt : Static mode alarm	2	R/W
63	A2MD R2ñD	Alarm 2 operation mode	0 norñ : Normal alarm action 1 LcH : Latching alarm action 2 Hold : Hold alarm action 3 LcHo : Latching & hold alarm action	0	R/W
64	A2HY R2HY	Hysteresis control for alarm 2	Low: 0.1 High: 50.0°C (90.0°F)	0.1°C (0.2°F)	R/W
65		Reserved			
66	ALF3 ALF3	Alarm 3 function (for TEC-4500 only)	0 PУH, : Process high alarm 1 PУLo : Process low alarm 2 dEH, : Deviation high alarm 3 dELo : Deviation low alarm 4 dbHL : Deviation band high/low alarm 5 EndP : End of profile alarm 6 Hold : Hold mode alarm 7 StARt : Static mode alarm	2	R/W
67	A3MD R3ñD	Alarm 3 operation mode (for TEC-4500 only)	0 norñ : Normal alarm action 1 LcH : Latching alarm action 2 Hold : Hold alarm action 3 LcHo : Latching & hold alarm action	0	R/W

Parameter Descriptions — Page 3 of 4

Register Address	Parameter Notation	Parameter Description	Range	Default Value	Data Type
68	A3HY R3HY	Hysteresis control for alarm 3 (for TEC-4500 only)	Low: 0.1 High: 50.0°C (90.0°F)	0.1°C (0.2°F)	R/W
69		Reserved			
70	SEL1 SEL1	Select 1'st parameter for home page	0 none : No parameter selected 1 inPt : INPT selected for home page 2 unit : UNIT selected for home page 3 dP : DP selected for home page 4 Pbi : PB1 selected for home page 5 ti1 : T1 selected for home page 6 tdi : TD1 selected for home page 7 Pbd : PB2 selected for home page 8 ti2 : T2 selected for home page 9 tdd : TD2 selected for home page 10 OFSt : OFST selected for home page 11 o1HY : O1HY selected for home page 12 CYC1 : CYC1 selected for home page 13 CYC2 : CYC2 selected for home page 14 CPB : CPB selected for home page 15 db : DB selected for home page 16 R1HY : A1HY selected for home page 17 R2HY : A2HY selected for home page 18 R3HY : A3HY selected for home page 19 dLAY : DLAY selected for home page	0	R/W
71	SEL2 SEL2	Select 2'nd parameter for home page	Same as SEL1	0	R/W
72	SEL3 SEL3	Select 3'rd parameter for home page	Same as SEL1	0	R/W
73	SEL4 SEL4	Select 4'th parameter for home page	Same as SEL1	0	R/W
74	SEL5 SEL5	Select 5'th parameter for home page	Same as SEL1	0	R/W
75	SEL6 SEL6	Select 6'th parameter for home page	Same as SEL1	0	R/W
76	SEL7 SEL7	Select 7'th parameter for home page	Same as SEL1	0	R/W
77	SEL8 SEL8	Select 8'th parameter for home page	Same as SEL1	0	R/W
78	CODE CODE	Security code for parameter protection	Low: 0 High: 9999 0=unprotected 1000= home page unprotected	0	R/W
79		Reserved			
80	STAR STAR	Set point value at start of each profile	0 PV : Current process value PV 1 SP1 : Controller set point value SP1 2 StSP : Start set point value STSP	0	R/W
81	END END	Set point value at end of each profile	0 FSP : Final set point value for each program 1 SP1 : Controller set point value 2 OFF : All outputs go to off except end of profile relay	0	R/W
82	DLAY DLAY	Delay time (hours /minutes) between profile initiation and profile start	Low : 0.00 High : 99.59	0	R/W

Register Address	Parameter Notation	Parameter Description	Range	Default Value	Data Type
83	PFR PFR	Power fail recovery	0 cont : Continue profile from the last set point value 1 PV : Start to run from PV 2 SP1 : Static mode, SP1 3 OFF : OFF mode	2	R/W
84	HBT HBT	Holdback wait time	Low : 0.00 High : 99.59 (hour:minute) 0.00= inf, infinite	1.00	R/W
85		Reserved			
86	PROF PROF	Profile number selected for view	Low: 1 High: 9	1	R/W
87	HBBd HBBd	Holdback band	Low: 1 High: 555°C (999°F)	—	R/W
88	STSP STSP	Start set point value	Low : SPLO High : SPHI	—	R/W
89	RMPU rnpU	Unit for ramp segment	0 HHmm : Hours. Minutes 1 mmSS : Minutes. Seconds 2 min : units per minute 3 IHR : units per hour	—	R/W
90	DLU dLU	Unit for dwell segment	0 HHmm : Hours. Minutes 1 mmSS : Minutes. Seconds	—	R/W
91	SGNO SGNO	Segment number	Low : 0 High:15(PROF=1~4) 31(PROF=5~7) 63(PROF=8,9)	—	R/W
92	SGTY SGTY	Segment type for the selected segment number	0 ramp : Ramp 1 dLL : Dwell 2 jump : Jump 3 End : End	3	R/W
93	TGSP TGSP	Target set point for ramp segment	Low : SPLO High : SPHI	—	R/W
94	RTRR rtrr	Time duration or Ramp rate for ramp segment	Low: 0 High: 5999	—	R/W
95	P2EV P2EV	States assignment of PID selection and event outputs for ramp and dwell segment.	Four-bit binary number (0=inactive 1=active) 0000 	—	R/W
96	HBTY HBTY	Holdback type	0. OFF : Holdback disabled 1. Lo : Deviation low holdback 2. Hi : Deviation high holdback 3. band : Deviation band holdback	—	R/W
97	DLT dLT	Duration time for dwell segment	Low: 0 High: 99.59	—	R/W
98	SEG SEG	Target segment number for the jump segment	Low : 0 High:15(PROF=1~4) 31(PROF=5~7) 63(PROF=8,9)	—	R/W
99	CYCL CYCL	Repeat number of cycles for the jump and end segment	Low: 1 High: 9999 10000 = inf, infinite	—	R/W
100	FSP FSP	Final set point for the end segment	Low: SPLO High: SPHI	—	R/W
101	OFSTL	Offset value for low point calibration	Low: -1999 high: 1999	0	R/W
102	OFSTH	Offset value for high point calibration	Low: -1999 high: 1999	0	R/W
103	ADLO	mV calibration low coefficient	Low: -1999 high: 1999	—	R/W
104	ADHI	mV calibration high coefficient	Low: -1999 high: 1999	—	R/W

Parameter Descriptions — Page 4 of 4

Register Address	Parameter Notation	Parameter Description	Range	Default Value	Data Type
105	RTDL	RTD calibration low coefficient	Low: -1999 high: 1999	—	R/W
106	RTDH	RTD calibration high coefficient	Low: -1999 high: 1999	—	R/W
107	CJLO	Cold junction calibration low coefficient	Low: -5.00 high: 40.00	—	R/W
108	CJHI	Cold junction calibration high coefficient	Low: -1999 high: 1999	—	R/W
109	DATE	Date code	Low: 0 High: 3719 (9C31)	—	R/W
110	SRNO	Serial number	Low: 0 High: 9999	—	R/W
111		Reserved			
112	BPL1	Bumpless transfer value of MV1	Low: 0 High: 100.00	—	R
113	BPL2	Bumpless transfer value of MV2	Low: 0 High: 100.00	—	R
114	CJCL	Sense voltage during cold junction calibration low	Low: 0 High: 7552	—	R
115	CALO	Input signal value during low point calibration	Low: -32768 High: 32767	0	R
116	CAHI	Input signal value during high point calibration	Low: -32768 High: 32767	1000	R
117	CAIN	Input sensor calibrated	Low: 0 High: 20	20	R
118		Reserved			
119		Reserved			
120		Reserved			
121		Reserved			
122		Reserved			
123		Reserved			
124		Reserved			
125		Reserved			
126		Reserved			
127		Reserved			
128	PV	Process value	Low: -32768 High: 32767	—	R
129	SV	Set point value for control	Low: SPLO High: SPHI	—	R
130	MV1 H - - -	Output 1 percentage value (Heating)	Low: 0.00 High: 100.00	—	*1
131	MV2 C - - -	Output 2 percentage value (Cooling)	Low: 0.00 High: 100.00	—	*1
132	STAT	Mode and operation status word	Bit 0 = Profile run mode Bit 1 = Profile hold mode Bit 2 = Static mode Bit 3 = Automatic tuning mode Bit 4 = Manual mode Bit 5 = Off mode Bit 6 = Failure mode Bit 7 = Profile running up Bit 8 = Profile running down Bit 9 = Profile soaking Bit 10 = Alarm 1 active Bit 11 = Alarm 2 active Bit 12 = Alarm 3 active Bit 13 = Event 1 on Bit 14 = Event 2 on Bit 15 = Event 3 on	—	R
133	EROR	Error Code	Low: 0 High: 40	—	R
134	PFSG	Current profile and segment runing	Low: 1.00 High: 9.63	—	R
135	TNSG	Total number of segments	Low: 1 High: 64	—	R
136	TTSG	Total time for segment runing	Low: 0 High: 99.59	—	R

Register Address	Parameter Notation	Parameter Description	Range	Default Value	Data Type
137	SPSG	Set point for current segment	Low:SPLO High: SPHI	—	R
138	TIME	Time remaining for the current segment	Low:00.00 High: 99.59	—	R
139	CYCL	Cycle remaining for the current loop	Low:1 High: 9999 10000=infinite	—	R
140	PROG	Program and version code of the product	Low: -32768 High: 32767	—	R
141	HBTR	Holdback time remaining for the current segment	Low: 0 High: 99.59	—	R
142	CMND	Command code	Low: -32768 High: 32767	—	R/W
143	JOB	Job code	Low: -32768 High: 32767	—	R/W

*1 Read only if in manual control mode.

Chapter 2 Installation

! Dangerous voltages capable of causing death are sometimes present in this instrument. Before installation or beginning any troubleshooting procedures, the power to all equipment must be switched off and isolated. Units suspected of being faulty must be disconnected and removed to a properly equipped workshop for testing and repair. Component replacement and internal adjustments must be made by a qualified maintenance person only.

! This instrument is protected throughout by double insulation to minimize the possibility of fire or shock hazards, do not expose this instrument to rain or excessive moisture.

! Do not use this instrument in areas under hazardous conditions such as excessive shock, vibration, dirt, moisture, corrosive gases or oil. This control is not to be used in hazardous locations as defined in Articles 500 and 505 of the National Electrical Code. The ambient temperature of the area should not exceed the maximum rating specified in chapter 6.

! Remove stains from this instrument using a soft, dry cloth. To avoid deformation or discoloration do not use harsh chemicals, volatile solvent such as thinner, or strong detergents to clean this instrument.

2-1 Unpacking

Upon receipt of the shipment, remove the unit from the carton and inspect the unit for shipping damage.

If there is any damage due to transit, report it and file a claim with the carrier. Write down the model number, part number, serial number, and date code for future reference when corresponding with Tempco. The serial number (S/N) is labeled on the box and the housing of the control. The date code is located on the internal components of the controller.

2-2 Mounting

Remove mounting clamps and insert the controller into the panel cutout. Reinstall the mounting clamps. Gently tighten screws in clamps (TEC-4500 only) until the controller front panel fits snugly in the cutout.

Figure 2.1 Mounting Dimensions

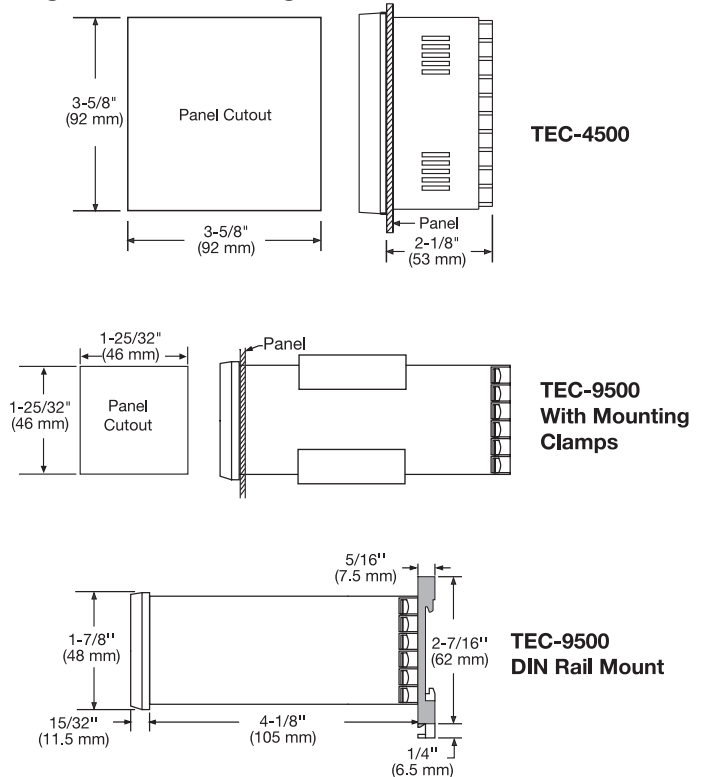

2-3 Wiring Precautions

- Before wiring, verify the correct model number and options on the label. Switch off the power while checking.
- Care must be taken to ensure that the maximum voltage rating specified on the label is not exceeded.
- It is recommended that the power for these units be protected by fuses or circuit breakers rated at the lowest value possible.
- All units should be installed inside a suitably grounded metal enclosure to prevent live parts from being accessible to human hands and metal tools.
- All wiring must conform to appropriate standards of good practice and local codes and regulations. Wiring must be suitable for the voltage, current, and temperature rating of the system.
- Beware not to over-tighten the terminal screws. The torque should not exceed 1 n-m (8.9 in-lb.).
- Unused control terminals should not be used as jumper points as they may be internally connected, causing damage to the unit.
- Verify that the ratings of the output devices and the inputs as specified in chapter 6 are not exceeded.
- Except for the thermocouple wiring, all wiring should be stranded copper with a maximum gauge of 18 awg.

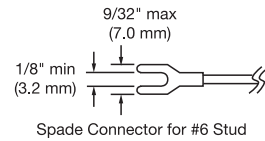

Figure 2.2
Lead Termination for
TEC-4500

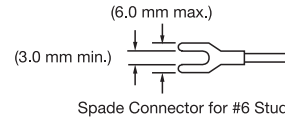

Figure 2.3
Lead Termination for
TEC-9500

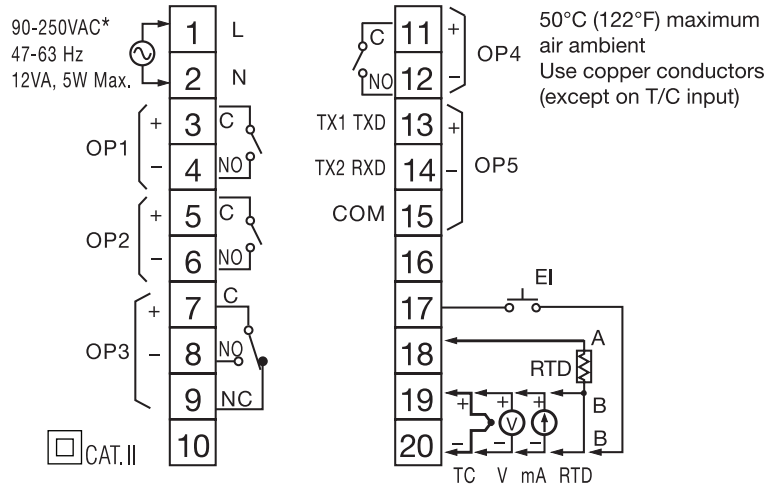

Figure 2.4
Rear Terminal Connection
for TEC-4500

OP5: + -
RS-232: TXD RXD COM
RS-485: TX1 TX2

CAT. II

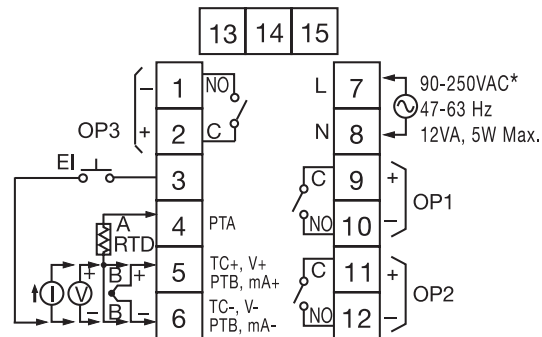

Figure 2.5
Rear Terminal Connection for TEC-9500

*Or low voltage (11-26 VAC/VDC) when ordered as specified. Non-polarized.

NOTE: ASTM thermocouples (American) the red colored lead is always negative.

2-4 Power Wiring

The controller is designed to operate at 11–26 VAC/VDC or 90–250 VAC. Check that the installation voltage corresponds to the power rating indicated on the product label before connecting power to the controller. The controller power input should be equipped with a fuse and switch as shown below in figure 2.7

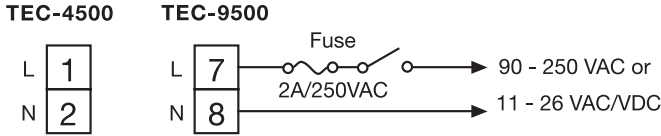

Figure 2.6 Power Supply Connections



This equipment is designed for installation in an enclosure which provides adequate protection against electric shock. The enclosure must be connected to earth ground.

Local requirements regarding electrical installation should be rigidly observed. Consideration should be given to prevent unauthorized personnel from accessing the power terminals.

2-5 Sensor Input Wiring

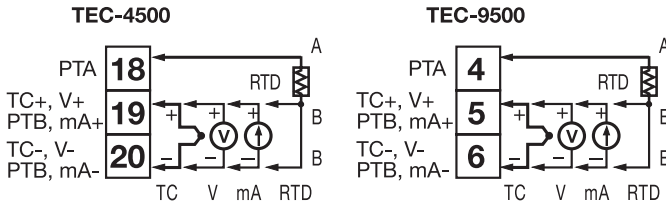

Figure 2.7 Sensor Input Wiring

2-6 Control Output Wiring

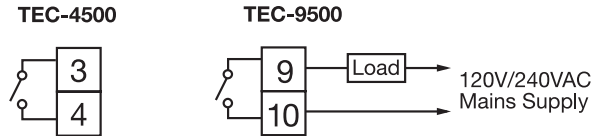

Figure 2.8 Output 1 Relay (2A, 240V Max.) or Triac (1A, 240V Max.) (SSR) to Drive Load

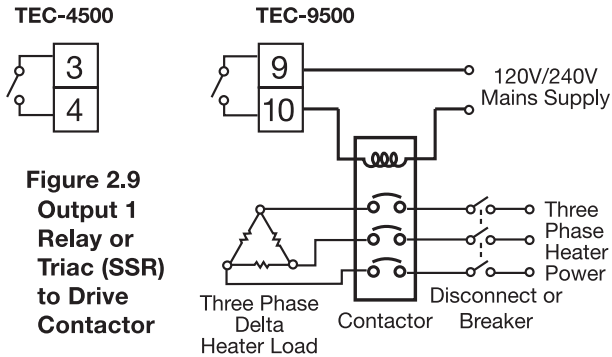

Figure 2.9 Output 1 Relay or Triac (SSR) to Drive Contactor

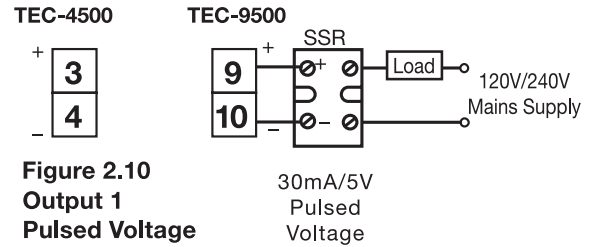

Figure 2.10 Output 1 Pulsed Voltage to Drive SSR

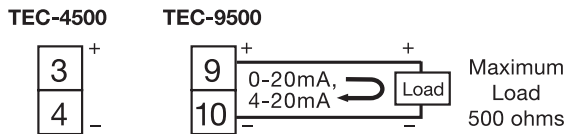

Figure 2.11 Output 1 Linear Current

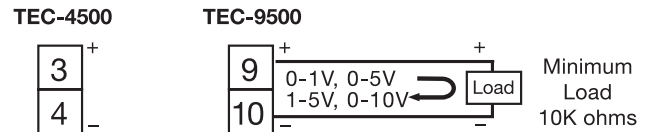

Figure 2.12 Output 1 Linear Voltage

Control Output Wiring, continued...

Control Output Wiring, continued...

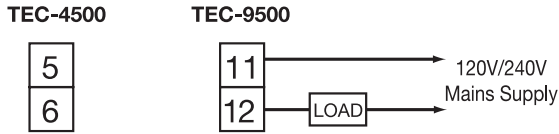

Figure 2.13 Output 2 or Triac (SSR) to Drive Load

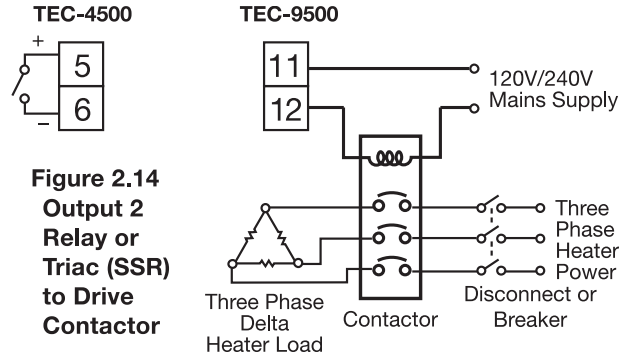

Figure 2.14 Output 2 Relay or Triac (SSR) to Drive Contactor

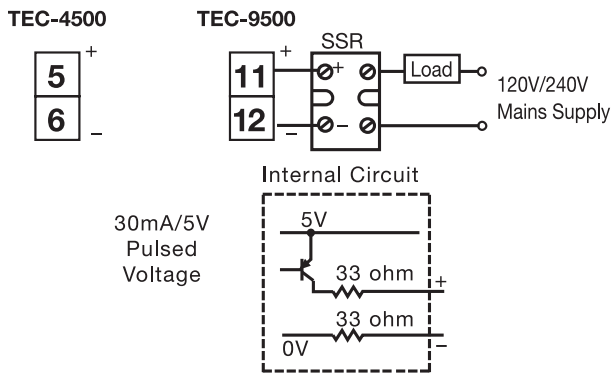

Figure 2.15 Output 2 Pulsed Voltage to Drive SSR

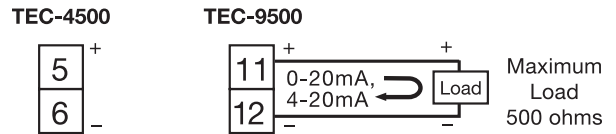

Figure 2.16 Output 2 Linear Current

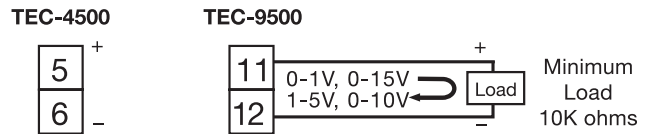

Figure 2.17 Output 2 Linear Voltage

2-7 Alarm Wiring

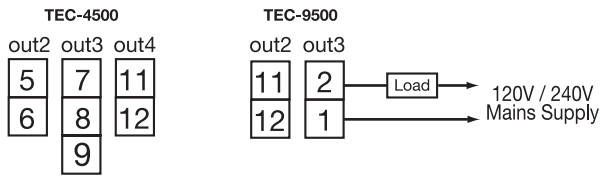

Figure 2.18 Alarm Output to Drive Load

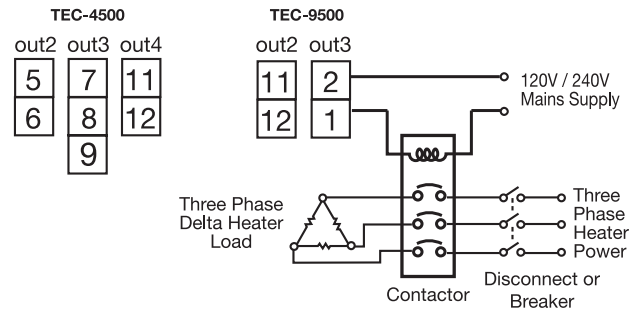

Figure 2.19 Alarm Output to Drive Contactor

2-8 Event Input Wiring

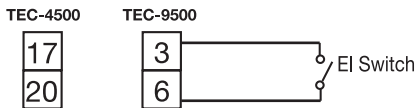

Figure 2.20 Event Input Wiring

2-9 Retransmission Output Wiring

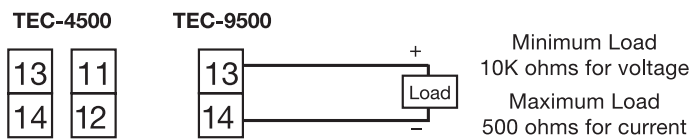

Figure 2.21 Retransmission Wiring

2-9 Data Communication

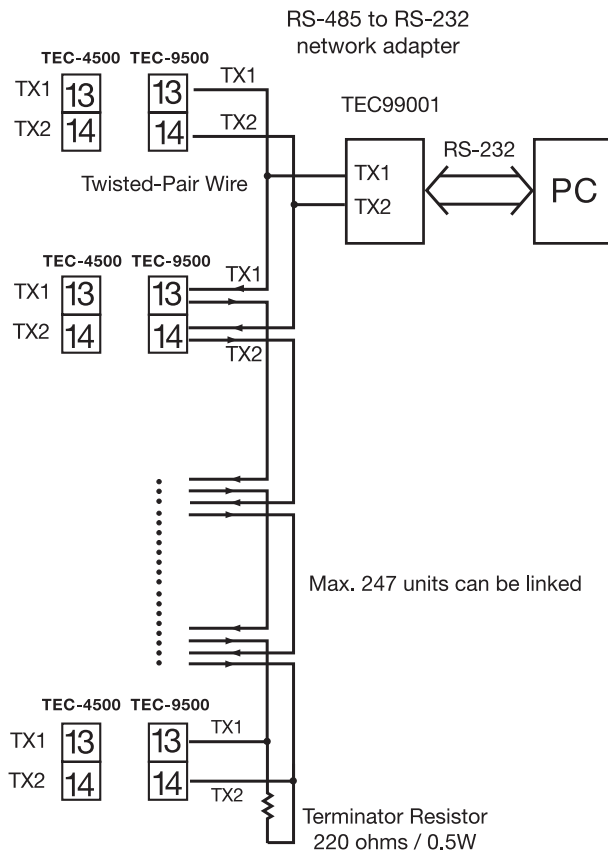

Figure 2.22 RS-485 Wiring

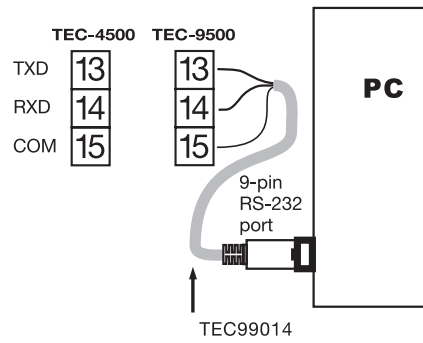

Figure 2.23 RS-232 Wiring

If you use a conventional 9-pin RS-232 cable instead of TEC 99014, the cable must be modified according to the following circuit diagram.

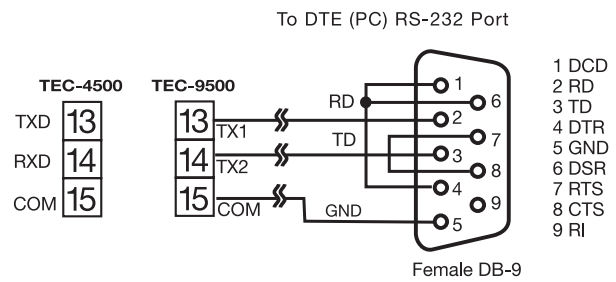

Figure 2.24 Configuration of RS-232 Cable

Chapter 3 Programming

The parameters stored in Home page can be obtained by pressing the scroll key $\left[\curvearrowright \right]$. The parameters stored in the Configuration page are obtained by pressing the page key $\left[\text{E} \right]$ 2 times to show *Prof*. Press and hold the page key $\left[\text{E} \right]$ for 5 sec and release. The display should then read *CONF*-the Configuration page, then press the scroll key $\left[\curvearrowright \right]$ to get to the desired configuration parameter. The upper display indicates the parameter symbol, and the lower display indicates the selected value of the parameter.

3-1 Lockout

There are two parameters which specify the data security function. These are PASS (password) and CODE (security code).

Value of CODE	Value of PASS	Results
0	Any value	All parameters are changeable
1000	=1000	All parameters are changeable
	\neq 1000	Only Home page parameters are changeable
Others	=CODE	All parameters are changeable
	\neq CODE	All parameters are not changeable

Table 3.1 Password Operation

3-2 Signal Input

INPT: Selects the sensor type or signal type for signal input.

Range: (thermocouple) Type J, K, T, E, B, R, S, N, L, C, P
(RTD) PT.DN, PT.JS
(Linear) 4-20 mA, 0-20 mA, 0-60 mA, 0-1V, 0-5V, 1-5V, 0-10V

UNIT: Selects the process unit

Range: °C, °F, PU (process unit). If the unit is neither °C nor °F, then select PU.

DP: Selects the resolution of process value.

Range: (For T/C and RTD) NO.DP, 1-DP
(For linear) NO.DP, 1-DP, 2-DP, 3-DP

INLO: Selects the low scale value for the linear type input.

INHI: Selects the high scale value for the linear type input.

How to use the conversion curve for linear type process values, INLO and INHI;

If 4-20mA is selected for INPT, SL specifies the input signal low (i.e., 4mA), SH specifies the input signal high (i.e., 20mA), S specifies the current input signal value, and the conversion curve of the process value is shown as follows:

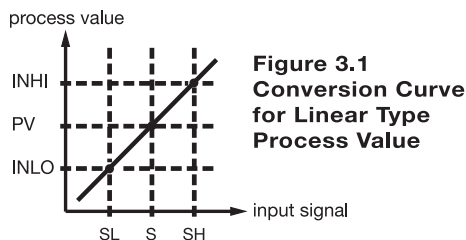

**Figure 3.1
Conversion Curve
for Linear Type
Process Value**

$$\text{Formula: } PV = INLO + (INHI - INLO) \frac{S - SL}{SH - SL}$$

Example: A 4-20 mA current loop pressure transducer with range 0-15 kg/cm² is connected to input, then perform the following setup:

INPT = 4-20 INLO = 0.00
INHI = 15.00 DP = 2-DP

Of course, you may select other value for DP to alter the resolution.

3-3 Event Input

The Event input accepts a digital type signal. The types of signal:

(1) relay or switch contacts, (2) open collector pull low and (3) TTL logic level, can be used to switch the event input.

One of eight functions can be chosen by using $E_i F_n$ (EIFN) contained in configuration page.

0 NONE : No event input function

1 RUN: Applicable when unit is in static mode or Off mode

Requires only momentary type input

When the event input is closed: the unit will enter run mode

2 HOLD: Applicable when unit is running

Event input closed: Hold the profile

Event input opened: Continue the profile

3 ABOT: Applies when unit is in run mode

Requires only momentary input

Event input closed: Unit will abort the current running profile and enter static mode.

4 MAN: Applies when unit is in static mode or run mode

Event input close: Outputs perform bumpless transfer into manual mode

Event input open: Unit will perform normal PID operation

5 FTRA: Applies when unit is in static mode or run mode

Event input close: Perform failure transfer function

Event input open: Unit will perform normal PID operation

6 OFF: Applies when unit is in static mode or run mode

Event input close: All outputs/alarm turn off, profile stops running

Event input open: If running, profile resumes where it was put into off condition, outputs/alarms active again as per configuration

7 PASS: Applies when unit is run mode

Requires only momentary input to pass to next segment

Event input close: Profile will move ahead by 1 segment

8 PID2: Applies when unit is in static mode or run mode

If chosen, and the event input is closed, the PB2, TI2 and TD2 will replace PB1, TI1 and TD1 for control.

9 RunHo: The RunHo parameter performs following function when the unit is in any mode:

Event input close: Performs run mode.

Event input open: Performs hold mode.

3-4 Control Outputs

There are four kinds of control modes that can be configured as shown in table 3.1.

Table 3.2 Heat-Cool Control Setup Value

Control Modes	OUT1	OUT2	O1HY	A1HY	CPB	DB
Heat only	<i>H.on.F</i> <i>H.tPC</i> <i>H.Lin</i>	×	☆	×	×	×
Cool only	<i>C.on.F</i> <i>C.tPC</i> <i>C.Lin</i>	×	☆	×	×	×
Heat: ON-OFF Cool: ON-OFF	<i>H.on.F</i>	<i>RLnF</i>	○	○	×	×
Heat: PID Cool: ON-OFF	<i>H.tPC</i> <i>H.Lin</i>	<i>RLnF</i>	×	○	×	×
Heat: PID Cool: PID	<i>H.tPC</i> <i>H.Lin</i>	<i>C.tPC</i> <i>C.Lin</i>	×	×	○	○

OUT1:
Output 1 Type

OUT2:
Output 2 Type

O1HY:
Output 1 Hysteresis

A1HY:
Alarm 1 Hysteresis

CPB:
Cooling Proportional Band

DB:
Heating Cooling Dead Band

× : Does not apply

○ : Adjust to meet process requirements

☆ : Required if ON-OFF control is configured

Control Outputs, continued...

Heat Only ON-OFF Control: Select *H.on.F* for OUT1. O1HY is used to adjust dead band for ON-OFF control. The heat only on-off control function is shown in the following diagram:

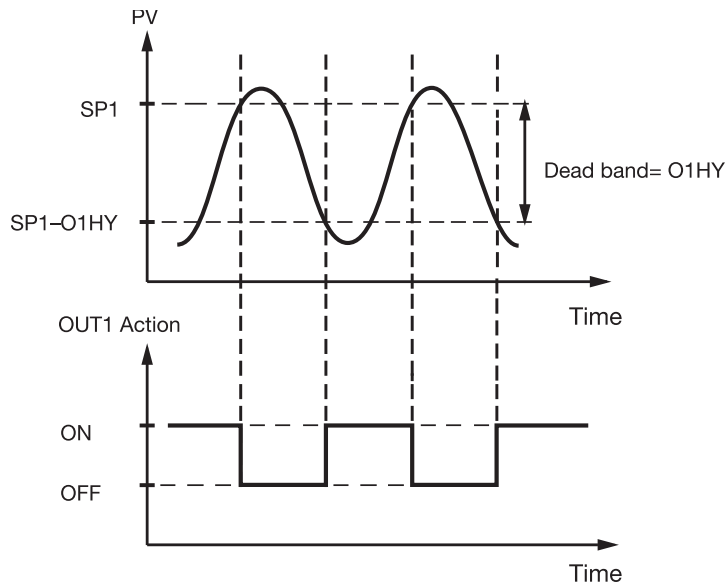

Figure 3.2 Heat Only ON-OFF Control

The ON-OFF control may introduce excessive process oscillation even if hysteresis is minimized. If ON-OFF control is set, PB1, TI, TD, PB2, T12, TD2, CYC1, CYC2, OFST, CPB and DB will be hidden and have no function in the system. The auto-tuning and bumpless transfer functions will be disabled as well.

Heat only P (or PD) control: Select H.TPC or H.LIN for OUT1 and set TI1 and TI2 to 0, OFST is used to adjust the control offset (manual reset). O1HY is hidden if PB is not equal to 0.

OFST function: OFST is measured in % with a range of 0–100.0%.

In a steady state (i.e. process has stabilized at a temperature), if the process value is lower than the set point by a constant value (we'll say 5°C) while the PB setting is set for 20°C, we can say the temperature is lower than the setpoint by 25% of the PB setting. This can be corrected by increasing the OFST setting to 25%. After adjusting the OFST value, the process value will eventually coincide with set point.

Note that using the P control (TI set to 0), disables auto-tuning.

Refer to Section 3-11 “manual tuning” for the adjustment of P and PD. Manual reset (adjust OFST) is sometimes not practical since the load may change from time to time and OFST may need to be adjusted repeatedly. PID control can avoid this situation.

Heat only PID control: Set H.TPC or H.LIN for OUT1 and a non-zero value for PB and TI. Perform auto-tuning for the new process, or set PB1, TI1, and TD1 with historical values. If the control result is still unsatisfactory, use manual tuning to improve control. See section 3-11 for manual tuning. The unit contains a very advanced PID and Fuzzy Logic algorithm to create a small overshoot and quick response to the process if it is properly tuned.

Cool only control: ON-OFF control, P (PD) control, and PID control can be used for cool only control for output 1. Set OUT1 to *C.on.F*, *C.TPC*, or *C.LIN*. The other functions for cool only ON-OFF control, cool only P (PD) control, and cool only PID control are the same as for heat only control except that the output variable (and action) for cool control is inverse to heat control.

Heat – Cool control: Three types of heat-cool combinations are available as shown in Table 3.1. Case 1 through 3 in Figure 3.3 show the heat PID and cool PID operation. Case 4 shows the heat PID and cool ON-OFF operation.

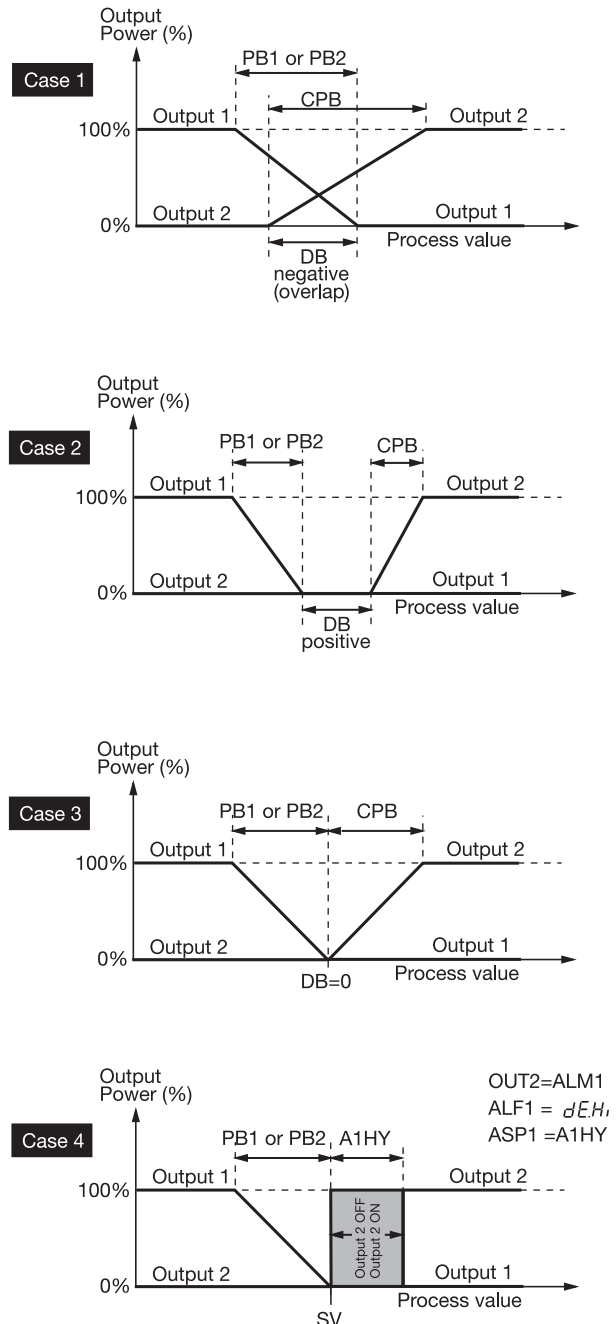

Figure 3.3 Heat-Cool Control

CPB (Cooling Proportional Band) Programming: The cooling proportional band is measured by % of PB with a range of 50-300%. Initially set CPB to 100% and examine the cooling effect. If the cooling action should be enhanced, then decrease CPB, if the cooling action is too strong, then increase CPB. The value of CPB is related to PB and its value remains unchanged throughout the auto-tuning procedures.

Adjustment of CPB is related to the cooling medium used. If air is used as the cooling medium, initially set CPB to 100%, then adjust as necessary. If oil is used as the cooling medium, initially set CPB to 125%, then adjust as necessary. If water is used as the cooling medium, initially set CPB to 250%, then adjust as necessary.

DB (Heating-Cooling Dead Band) Programming: The adjustment of DB is dependent on the system requirements. If a more positive value of DB (greater dead band) is used, an unwanted cooling action can be avoided but an excessive overshoot over the set point can occur. If a more negative value of DB (greater overlap) is used, an excessive overshoot over the set point can be minimized, but an unwanted cooling action can occur. The DB is adjustable in the range of -36.0% to 36.0% of PB. A negative DB value shows an overlap area over which both outputs are active. A positive DB value shows a dead band area over which neither output is active.

NOTE: ON-OFF control may result in excessive overshoot and undershoot problems in the process. P (or PD) control will result in a deviation of process value from the set point. It is recommended to use PID control for heat-cool control to produce a stable and zero offset process value.

Other setup required: CYC1, CYC2, O1FT and O2FT

CYC1 is adjusted according to the type of output device. Generally, use 0.5~2 seconds for CYC1 if SSRD or SSR is used for O1TY; 10~20 seconds if relay is used for O1TY; and CYC1 is ignored if a linear output is used. Similar conditions are applied for CYC2 selection.

See section 3-9 for O1FT and O2FT adjustment.

The ON-OFF control may introduce excessive process oscillation even if hysteresis is minimized. If ON-OFF control is set, PB1, TI, TD, PB2, T12, TD2, CYC1, CYC2, OFST, CPB and DB will be hidden and have no function in the system. The auto-tuning and bumpless transfer functions will be disabled as well.

Heat only P (or PD) control: Select H.TPC or H.L I N for OUT1 and set TI1 and TI2 to 0, OFST is used to adjust the control offset (manual reset). O1HY is hidden if PB is not equal to 0.

OFST function: OFST is measured by % with a range of 0–100.0%. In a steady state (i.e. process has been stabilized), if the process value is lower than the set point, a definite value say 5°C while 20°C is used for PB, that is lower than setpoint by 25%, then increase OFST 25%, and vice-versa. After adjusting OFST value, the process value will be varied and eventually coincide with set point. Using the P control (TI set to 0), disables auto-tuning.

Refer to section 3-11 “manual tuning” for the adjustment of P and PD. Manual reset (adjust OFST) is not practical because the load may change from time to time and OFST may need to be adjusted repeatedly. The PID control can avoid this situation.

Heat only PID control: Set H.TPC or H.L I N for OUT1 and a non-zero value for PB and TI. Perform auto-tuning for the new process, or set PB1, TI1, and TD1 with historical values. If the control result is still unsatisfactory, use manual tuning to improve control. See section 3-11 for manual tuning. The unit contains a very advanced PID and Fuzzy Logic algorithm to create a small overshoot and quick response to the process if it is properly tuned.

OFST function: OFST is measured in % with a range of 0–100.0%. In a steady state (i.e. process has stabilized at a temperature), if the process value is lower than the set point by a constant value (we'll say 5°C) while the PB setting is set for 20°C, we can say the temperature is lower than the setpoint by 25% of the PB setting. This can be corrected by increasing the OFST setting to 25%. After adjusting the OFST value, the process value will eventually coincide with set point.

Note that using the P control (TI set to 0), disables auto-tuning.

Refer to section 3-11 “manual tuning” for the adjustment of P and PD. Manual reset (adjust OFST) is sometimes not practical since the load may change from time to time and OFST may need to be adjusted repeatedly. PID control can avoid this situation.

3-5 Alarms

The unit can be configured with up to three alarm outputs using OUT2, OUT3, and OUT4. There are 9 types of alarm functions that can be selected, and 4 kinds of alarm modes are available for each alarm function.

Py.Hi: A process high alarm is independent of the set point. When the process value is higher than the alarm value, a process high alarm occurs, the alarm is off when the process value is lower than alarm value (minus) alarm hysteresis. Fig. 3.4 shows the process high alarm operation.

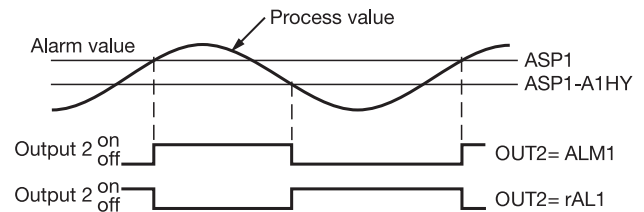

Figure 3.4 Process high alarm 1 operation

Py.Lo: A Process low alarm is independent of the set point. When the process value is lower than the alarm value, a process low alarm occurs. The alarm is off when the process value is higher than alarm value + alarm hysteresis. Fig. 3.5 shows the process low alarm operation.

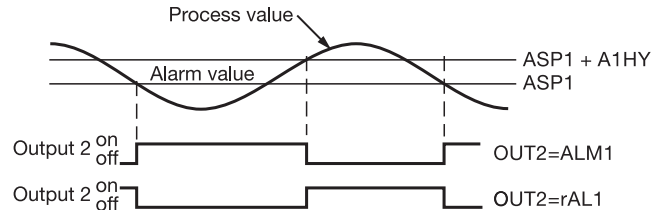

Figure 3.5 Process low alarm 1 operation

dE.Hi: A deviation high alarm alerts the operator when the process deviates too high from the set point value. When the process value is higher than SV+ASP1, a deviation high alarm occurs. The alarm is off when the process is lower than SV+ASP1-A1HY. Figure 3.6 shows the deviation high alarm operation.

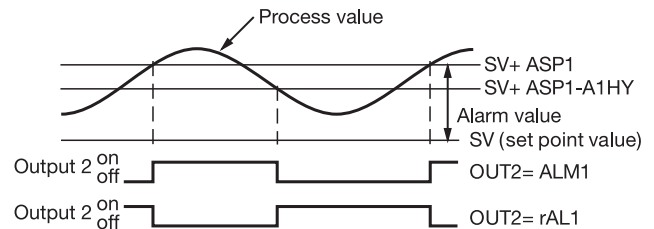

Figure 3.6 Deviation high alarm 1 operation

dE.Lo: A deviation low alarm alerts the operator when the process deviates too low from the set point value. When the process is lower than SV+ASP1 (ASP1 is negative value), a deviation low alarm occurs. The alarm is off when the process is higher than SV+ASP1+A1HY. Figure 3.7 shows the deviation low alarm operation.

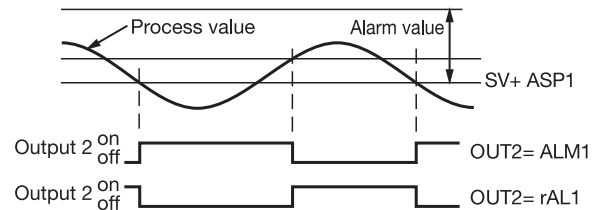

Figure 3.7 Deviation low alarm 1 operation

db.HL: A deviation band high/low alarm presets two trigger levels relative to set point value. The two trigger levels are SV+ASP1 and SV-ASP1 for alarm. When the process value is higher than SV+ASP1 or lower than SV-ASP1, a deviation band alarm occurs. When the process value is within the trigger levels SV+ASP1-A1HY and SV-ASP1+A1HY (where ASP1 must be positive value), the alarm is in a normally open state. Figure 3.8 shows the deviation band alarm 1 operation.

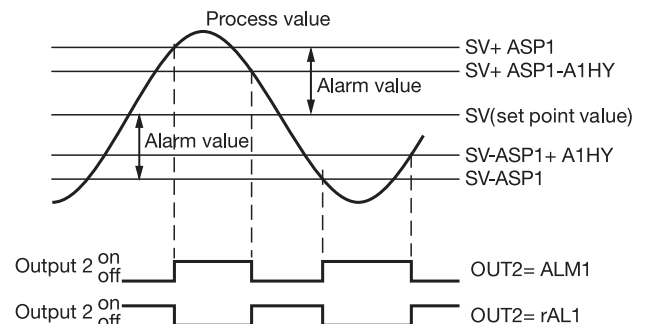

Figure 3.8 Deviation band alarm 1 operation

The above description is based on alarm 1 which is selected for output 2. The operations of alarm 2 and alarm 3 are same as alarm1. In the above description, SV denotes the current set point value for control which is different from SP1 as the profile mode is performed.

Continued on next page

End.P: An end of profile alarm is energized when a running profile is complete.

HoLd: A hold mode alarm is energized whenever a profile is in “Hold” mode.

StAt: A static mode alarm is energized whenever the controller is in “Static” mode.

The alarm modes (A1MD, A2MD and A3MD) are set by using a three bit of binary number.

alarm mode value	Description
<i>noRn</i>	A direct acting normal alarm output is off in the non-alarm condition and on in an alarm condition. The output state is inverted if a reverse alarm output is selected for OUT2, OUT3 or OUT4.
<i>LtCh</i>	A direct acting latching alarm output is on in an alarm condition and it will remain unchanged even if the alarm condition is cleared. The output state is inverted if a reverse alarm output is selected for OUT2, OUT3 or OUT4. The latching alarm output is off when both <input type="checkbox"/> and <input type="checkbox"/> keys are pressed, once the alarm condition is removed.
<i>HoLd</i>	A direct acting holding alarm output is off even if an alarm condition may occur on power up. This will prevail until the alarm condition returns to the "inactive" condition, thereafter the alarm will operate normally. The output state is inverted if a reverse alarm output is selected for OUT2, OUT3 or OUT4.
<i>LtHo</i>	A direct acting latching and holding alarm performs both holding and latching alarm functions. The output state is inverted if a reverse alarm output is selected for OUT2, OUT3 or OUT4.

Table 3.3 Alarm mode description

3-6 Configure Home Page

Conventional controllers are designed with a fixed parameter scrolling. This unit has the flexibility for you to select parameters which are most useful to you, and put these parameters in the home menu. Hence, you can have a custom home menu.

Up to eight parameters can be selected for the home menu. These are: SEL1~SEL8 in the configuration menu. There are 19 parameters that can be selected for SEL1~SEL8, these are: INPT, UNIT, DP, PB1, TI1, TD1, PB2, TI2, TD2, OFST, O1HY, CYC1, CYC2, CPB, DB, A1HY, A2HY, A3HY, and DLAY.

When using the up-down key to select the parameters, you may not obtain all of the above parameters. The number of visible parameters is dependent on the configuration of the controllers. The hidden parameters for a specific application are also hidden from the SEL1~SEL8 parameters.

3-7 User Calibration

Each unit is calibrated in the factory before shipment. You still can modify the calibration conditions after shipment.

Purpose of user Calibration

The basic calibration of the unit is highly stable and set for life. User calibration allows you to offset the permanent factory calibration to either:

1. Calibrate the unit to meet your reference standard.
2. Match the calibration of the unit to that of a particular transducer or sensor input.
3. Calibrate the unit to suit the characteristics of a particular installation.
4. Remove long term drift in the factory set calibration.

There are two parameters: offset low value **OFSTL** and offset high value **OFSTH** which are adjusted to correct the error of process value.

See section 1-5 for key operation flowchart, press **[E]** key until low calibration page is obtained. Send the low signal to the input of unit, then press **[↻]** key. If the process value (the upper display) is different from the input signal, then you can use **[▲]** and **[▼]** keys to change the OFSTL value (the lower display) until the process value is equal to the value you want. Then press and hold **[E]** key for 5 seconds. The low point calibration is finished. Apply the same procedure for the high point calibration.

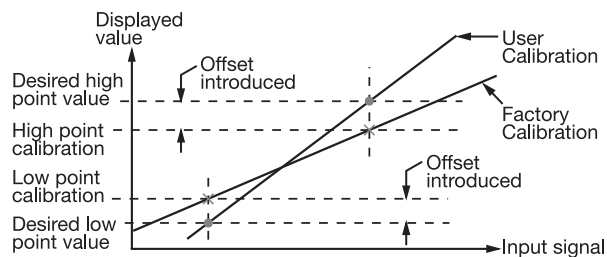

Figure 3.9 Two point user calibration

The two points construct a straight line. For the purpose of accuracy it is best to calibrate with the two points as far apart as possible. After user calibration is complete, the input type will be stored in the memory. If the input type is changed, a calibration error will occur and an error code **CRER** is displayed.

3-8 Digital Filter

In certain applications, the process value is too unstable to be read, possibly due to electrical noise. A programmable low-pass filter incorporated in the controller is used to improve this. It is a first-order filter with the time constant specified by the FILT parameter. The default value of FILT is set at 0.5 seconds before shipping. Adjust FILT to change the time constant from 0 to 60 seconds. 0 seconds means no filter is applied to the input signal. The filter is characterized by the following diagram:

Note

The filter is available only for PV, and is performed for the displayed value only. The controller is designed to use an unfiltered signal for control even if the filter is applied. A lagged (filtered) signal, if used for control, may produce an unstable process.

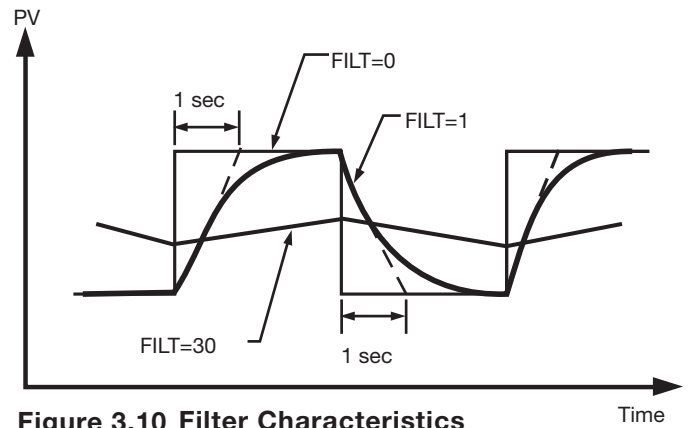

Figure 3.10 Filter Characteristics

3-9 Failure Transfer

The controller will enter failure mode if one of the following conditions occurs:

1. **SBER** occurs due to input sensor break, or input current is below 1mA if 4–20 mA is selected, or input voltage is below 0.25V if 1–5V is selected.
2. **ADER** occurs due to the A-D converter of the controller failing.

Output 1 and output 2 will perform the failure transfer function as the controller enters failure mode.

Output 1 failure transfer, if activated, will perform:

1. If output 1 is configured as proportional control (ie. HTPC, CTPC, HLIN, or CLIN selected for OUT1), and BPLS is selected for O1FT, then output 1 will perform bumpless transfer. Thereafter, the previous average value of MV1 will

be used for controlling output 1.

2. If output 1 is configured as proportional control ($PB \neq 0$), and a value of 0 to 100.0% is set for O1FT, then output 1 will perform failure transfer. Thereafter, the value of O1FT will be used for controlling output 1.
3. If output 1 is configured as ON-OFF control (ie. HONF or CONF is selected for OUT1), then output 1 will transfer to off state if OFF is set for O1FT and transfer to on state if ON is set for O1FT.

Output 2 failure transfer, if activated, will perform:

1. If OUT2 is configured as CTPC or CLIN, and BPLS is selected for O2FT, then output 2 will perform a bumpless transfer. Thereafter, the previous average value of MV2 will be used for controlling output 2.

2. If OUT2 is configured as CTPC or CLIN, and a value of 0 to 100.0% is set for O2FT, then output 2 will perform failure transfer. Thereafter, the value of O1FT will be used for controlling output 2.

3. If OUT2 is configured as alarm function, and OFF is set for O2FT, then output 2 will transfer to off state. Otherwise, output 2 will transfer to on state if ON is set for O2FT.

OUT3 and OUT4 failure transfer is activated if the controller enters failure mode. Thereafter, the alarm will transfer to the ON or OFF state which is determined by the set value of O3FT or O4FT.

3-10 Auto-tuning

! The auto-tuning process can be performed at any set point. The process will oscillate around the set point during the tuning process. Set the set point at a lower value if overshooting beyond the normal process value is likely to cause damage. Overshooting is common during auto-tuning.

Auto-tuning is applied in cases of:

- Initial setup for a new process
- The set point or load has changed substantially from the previous auto-tuning value
- The control result is unsatisfactory

Operation:

1. Set the correct values for the setup menu of the unit, but do not set a zero value for PB or TI, or auto-tuning will be disabled.
2. Set EIFN = PID2 if a second set of PID parameters is required to be tuned.
3. Set the set point to a normal operating value, or a lower value if overshooting beyond the normal process value is likely to cause damage. Enter the A-T mode from the “mode” menu. Select “A-T”, then press and hold the “E” button until the upper display begins to flash.
4. If the system needs to use a second set of PID values, then after the first auto-tuning is complete, close the event input of the unit and repeat step 3 for the second set of PID values.

Auto-tuning mode is disabled as soon as either failure mode or manual control mode is entered.

Procedures:

Auto-tuning can be applied either as the process is warming up (cold start), or when the process is in a steady state (warm start). After the auto-tuning procedures are completed, the AT indicator will cease to flash and the unit will revert to PID control using its new PID values. The PID values obtained are stored in the nonvolatile memory.

ATER Auto-Tuning Error

If auto-tuning fails an ATER message will appear on the upper display in the following cases:

- If PB exceeds 9000 PU, 900.0°F or 500.0°C
- if TI exceeds 3600 seconds
- if the set point is changed during the auto-tuning procedure.

Solutions to **ATER**

1. Try auto-tuning once again.
2. Don't change the set point value during the auto-tuning procedure.
3. Don't set a zero value for PB and TI.
4. Use manual tuning instead of auto-tuning (see Section 3-11).
5. Touch RESET key to reset **ATER** message.

3-11 Manual Tuning

In certain applications, auto-tuning may be inadequate for the control requirements. You can try manual tuning for these applications.

If the control performance using auto-tuning is still unsatisfactory, the following rules can be applied for further adjustment of PID values:

ADJUSTMENT SEQUENCE	SYMPTOM	SOLUTION
(1) Proportional Band (PB)	Slow Response	Decrease PB
	High overshoot or Oscillations	Increase PB
(2) Integral Time (TI)	Slow Response	Decrease TI
	Instability or Oscillations	Increase TI
(3) Derivative Time (TD)	Slow Response or Oscillations	Decrease TD
	High Overshoot	Increase TD

Table 3.4 PID Adjustment Guide

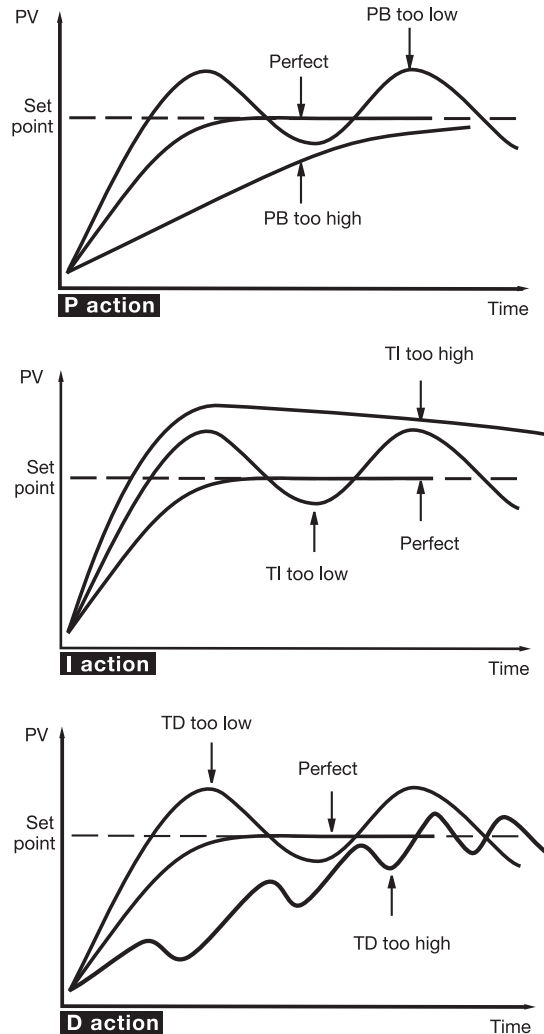

Figure 3.11 Effects of PID Adjustment

Figure 3.11 shows the effects of PID adjustment on process response.

3-12 Manual Mode

Operation

To enable manual control, the password PASS should be set with a value equal to CODE (except CODE=0).

Press **[E]** key to get *modE* (mode select), then use the **[▲]** and **[▼]** keys to obtain *MAN* (Man). Press **[E]** for 5 seconds, the controller is now in manual mode. The upper display will begin to flash and the lower display will show *H_ _ _* or *C_ _ _*. *H_ _ _* indicates control percentage value for heating output and *C_ _ _* indicates control percentage value for cooling output. Now you can use the up and down keys to adjust the percentage values for the heating or cooling output in relation to *CLC1*.

The controller performs open loop control as long as it stays in manual control mode.

Exit Manual Control

Pressing the **[▲]** and **[▼]** keys together will cause the controller to revert to its normal display mode.

3-13 Data Communication

The controllers support Modbus RTU protocol for data communication. Other protocols are not available for this series.

Two types of interfaces are available for data communication. These are RS-485 and RS-232 interface. Since RS-485 uses a differential architecture to drive and sense signals instead of a single-ended architecture like the one used for RS-232, RS-485 is less sensitive to noise and is more suitable for communication over a longer distance. RS-485 can communicate without error over a 1km distance while RS-232 is not recommended for a distance of over 20 meters.

Using a PC for data communication is the most economical method. The signal is transmitted and received through the PC communication port (generally RS-232). Since a standard PC can't support an RS-485 port, a network adapter (such as TEC99001) must be used to convert RS-485 to RS-232 if a PC is used. Up to 247 RS-485 units can be connected to one RS-232 port; therefore a PC with four comm ports can communicate with 988 units.

Setup

Enter the configuration menu. Select COMM for OUT5. Set unequal addresses for any units that are connected to the same port. Set the baud rate (BAUD), parity bit (PARI), and stop bit (STOP) so that these values are accordant with PC setup conditions.

If you use a conventional 9-pin RS-232 cable instead of TEC99014, the cable should be modified for proper operation of RS-232 communication according to section 2-10.

Refer to chapter 7 for a complete technical description of the Modbus Communications Protocol.

3-14 Process Variable (PV) Retransmission

The controller can output (retransmit) the process value or setpoint value via its retransmission terminals RE+ and RE- provided that the retransmission option is ordered. To accomplish this, you can select

rEPV (REPV) or *rESP* (RESP) for OUT4 (TEC-4500 only) or OUT5.

The following parameters should be configured for retransmission:

OP4L : Low limit value for output 4

OP4H : High limit value for output 4

REL4 : Retransmission low scale value for output 4

REH4 : Retransmission high scale value for output 4

OP5L : Low limit value for output 5

OP5H : High limit value for output 5

REL5 : Retransmission low scale value for output 5

REH5 : Retransmission high scale value for output 5

Example:

If you want to output 4 mA for PV at 0°C and 20mA for PV at 1000°C via output 5, then you should set the following parameters:

OUT5 = *rEPV*

OP5L = 20.0 (%), since 20% of a 0-20mA output module equipped will output 4 mA (20% of 20mA span).

OP5H = 100.0 (%)

REL5 = 0°C

REH5 = 1000°C

3-15 Output Scaling

Output scaling can be applied during cases of linear output (case 1 in Fig. 3.12) and retransmission (case 2 in Fig. 3.12). The Out.L or Out.H may be any % of the total span according to the output module installed.

Linear output modules are 0-20mA for current or 0-10VDC for voltage.

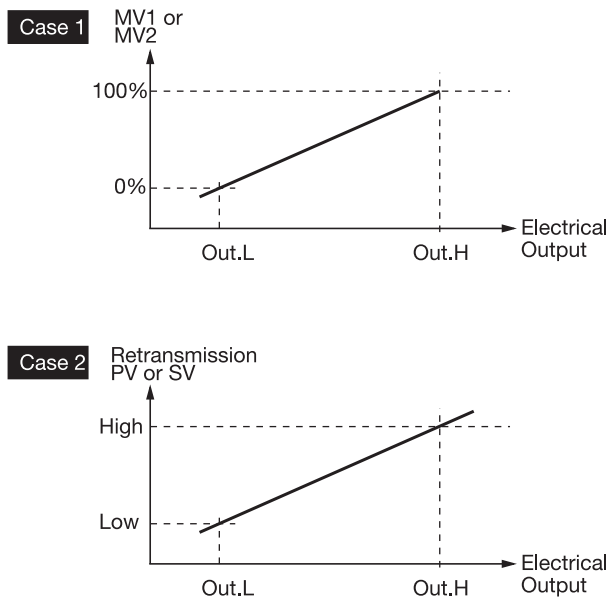

Figure 3.12 Output Scaling Function

Chapter 4 Ramp-Soak Operation

4-1 What is a set point profile?

Many applications need to vary temperature or process value with time.

Such applications need a controller which varies a set point as a function of time.

The profiling controllers TEC-4500 and TEC-9500 can do this.

The set point is varied by using a set point profile. The profile is stored as a series of "ramp" and "dwell" segments, as shown below.

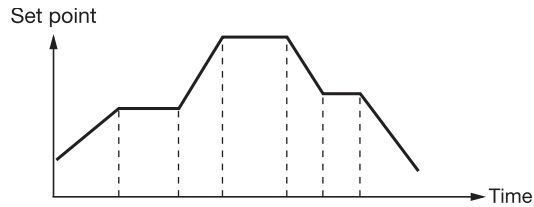

Figure 4.1 Set point profile

In each segment you can define the state of up to 3 event outputs which can drive either relay, logic or triac outputs, depending on the modules installed. A profile is executed either once, repeated a set number of times, or repeated continuously. If repeated a set number of times, then the number of cycles must be specified as part of the profile.

There are four types of segments:

Ramp		The set point ramps linearly, from its current value to a new value, either at a rate (ramp rate), or in a set time (ramp time). You must specify the ramp rate or the ramp time and the target set point when creating or modifying a profile.
Dwell		The set point remains constant for a specified period.
Jump		It is often necessary to jump backward and run the loop a set number of cycles.
End		The profile either ends in this segment or repeats a set number of cycles. The profile stops after the repeated cycles are finished.

Table 4.1 Segment Types

4-2 Segment Connection

Four kinds of combination are allowable for connecting segments, these are

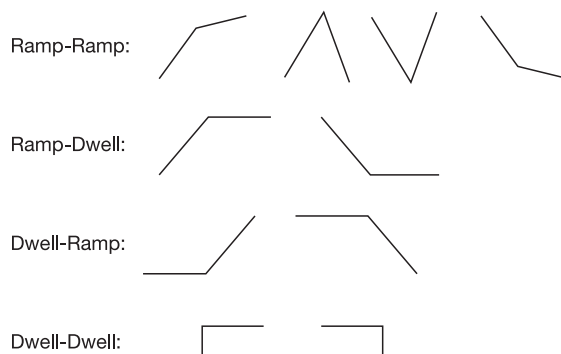

4-3 Profile Modes

The profile has eight operating modes:

Mode	Description	Indication
Run	In run mode, the controller varies the set point according to the stored profile values.	RUN light on
Hold	In hold mode, the profile is frozen at its current point. In this state you can make temporary changes to any profile parameter (for example, a target set point, a dwell time or the time remaining in the current segment). Such changes will only remain effective until the profile is reset and run again, when they will be overwritten by the stored profile values.	HLD light on
Holdback	Holdback indicates that the process value is lagging the set point by more than a preset amount (holdback band HBBD) and that the profile is in HOLD, waiting for the process to catch up.	HLD light flashes
Static	In static mode, the profiler is inactive and the controller act as a standard controller, with the set point determined by the value set in the lower display.	Both RUN and HLD light are off
A-T	In automatic tuning mode, the profiler is inactive and the controller executes automatic tuning function at its static mode set point.	Both RUN and HLD light are off. Upper display flashes.
MAN	In manual mode, the profiler is inactive and the heating and cooling output values can be adjusted at the lower display by up-down keys.	Both RUN and HLD light are off. Upper display flashes. Lower display shows <i>H_---</i> or <i>ℓ---</i>
OFF	In off mode, the profiler is inactive and all the outputs are disabled. That is all the control outputs, alarms and event outputs are off.	Both RUN and HLD light are off. Upper display shows OFF and flashes.
End	The profile is complete.	Both RUN and HLD lights flash.

Table 4.2 Profiler Mode

4-4 Running, Holding and Aborting a Profile

Press and release page key **[E]** until mode page is obtained. The upper display will show *mode*. Press the up/down key until *run* is obtained on the lower display. Press the **[E]** page key for 5 seconds and release. The “Run” light will illuminate as the controller enters RUN mode. If *Hold* is obtained, pressing the page key for 5 seconds will enter HOLD mode

The operator may abort (i.e. terminate) the current profile by holding the **[E]** key for more than 5 seconds when the lower display shows *START*. When the program is aborted, the profile is inactive and enters static mode. At the same time both the RUN light and HLD light turn off.

If the "RUN" and "HLD" LED's are blinking simultaneously, it indicates the end of the current profile. Reset the profile by pressing UP and DOWN keys together to take to Profile start segment PFSG=1.00. Select the profile and segment by using up/down arrows and pressing Enter Key. P1.00 indicates profile 1 and segment 00 is selected.

Please refer to Section 1-5 for key operation.

4-5 Viewing and Modifying profile progress

There are three parameters: PFSG, TIME, CYCL which indicate the status of profile progress. The operator can easily view these parameters: the current profile and segment number, the time remaining for the current segment, and the cycle remaining for the current profile on the home page.

When a profile is running, if it is necessary to jump to another segment, then it requires holding of the current profile. After going to hold mode, go to current segment PSEG by pressing  button, then use "Up" and "Down" buttons to modify the segment and run the profile again.

When a profile is running, if it is necessary to change dwell time or ramp rate of the current segment, then it requires holding of current profile. Press  button, twice to go to "tīnē", and then modify the value and run the profile again.

When profile is running, if it is necessary to modify the next segment data, no need to hold the current profile, modifications can be done directly from the profile configuration menu.

4-7 Holdback

As the set point ramps up or down (or dwells), the measured value may lag behind or deviate from the set point by an undesirable amount. "Holdback" is available to freeze the profile at its current state should this occur. The action of Holdback is the same as a deviation alarm. It can be enabled or disabled.

Holdback has three parameters: **HBT**-holdback wait time, **HBBD**-holdback band and **HBTY**-holdback type. If the error from the set point exceeds the set holdback band (HBBD), then the holdback feature, if enabled, will automatically freeze the profile at its current point and flash the HLD light. At the same time, the holdback timer begins to count. When the value of holdback timer exceeds the value of holdback wait time HBT, the profile will no longer be frozen and the profile will continue. An error code *HbEr* will be displayed if the holdback timer finishes before the process value "catches up" to the setpoint. When the error comes within the holdback band (HBBD), the program will resume normal running. There are four different Holdback types. The choice of type is made by setting HBTY parameter when creating a profile, and may be one of the following:

- oFF* – Disables Holdback - no action is taken.
- Lo* – Deviation Low Holdback holds the profile timer if the process value deviates below the set point by more than the holdback band (HBBD).
- Hi* – Deviation high holdback holds the profile timer if the process value deviates above the set point by more than the holdback band (HBBD).
- bAnd* – Deviation Band Holdback is a combination of the two. It holds the profile timer if the process value deviates either above or below the set point by more than the holdback band (HBBD).
HBT is a global parameter which is common to all profiles.
HBBD is a parameter which applies to a specific profile.
HBTY is a parameter which applies to a segment in a specific profile.

4-6 Start

The parameter "StAr" in the configuration menu is used to specify the starting setpoint for the profile.

There are three values for the starting point, these are:

PV: Process value: starts profile at whatever the current temperature is

SP1: starts profile at whatever the static setpoint is set at

STSP: Uses the "STSP" value in the profile configuration as the starting setpoint

The normal method is to start from the process value, because this will produce a smooth and bumpless start to the process. However, if you want to guarantee the time period of the first segment, you should set SP1 or STSP for the start point.

Holdback on dwell

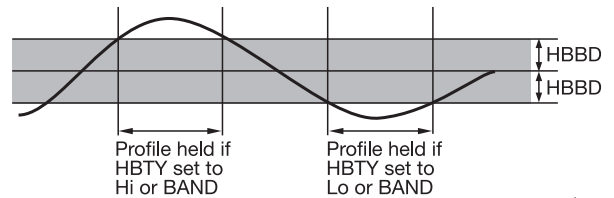

Holdback on positive ramp

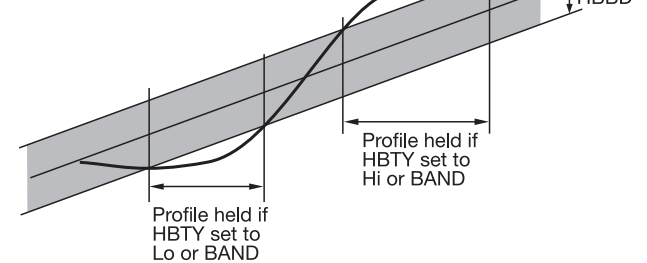

Holdback on negative ramp

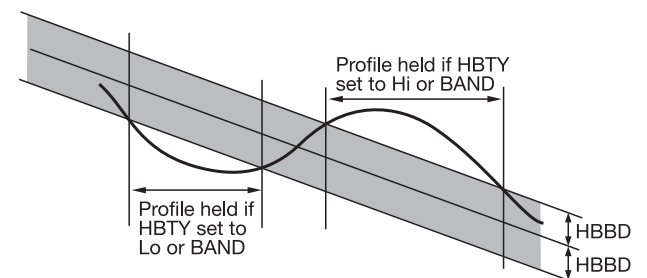

Figure 4.2 Holdback operation

4-8 Power Failure

If power is lost and then restored while a profile is running, the behavior of the profile is determined by the setting of the parameter " PFR " (power fail recovery) in the profile configuration menu. This can have one of 4 settings - *cont*, *PV*, *SP1*, or *OFF*. If *cont* is selected, then when power is restored the profile continues from where it was interrupted when power was lost.

The parameters such as set point value (SV), time remaining (TIME), and cycle remaining (CYCL), will be restored to their power-down values. For an application that needs to bring the process value to the set point value as soon as possible, *cont* is the best choice. The two diagrams below illustrate the respective responses, Fig. 4.3 if power fails during a dwell segment and Fig. 4.4 if it fails during a ramp segment.

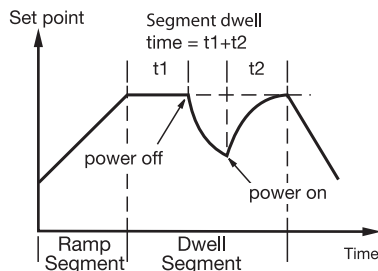

Figure 4.3 Recovery from profile at dwell segment

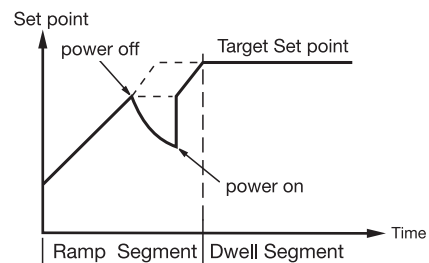

Figure 4.4 Recovery from profile at ramp segment

If *PV* is selected, then when power is restored the set point starts at the current process value, and then runs to the target set point of the active segment. This choice provides a smoother recovery. The two diagrams below illustrate the respective responses, Fig. 4.5 if power fails during a dwell segment and Fig. 4.6 if it fails during a ramp segment.

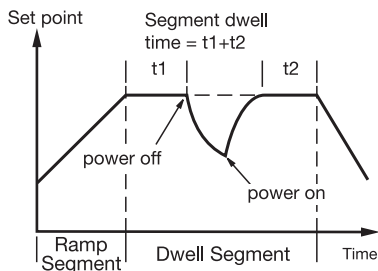

Figure 4.5 Recovery from PV at dwell segment

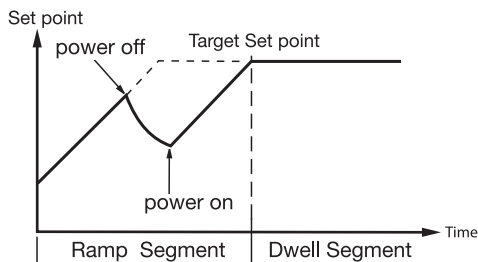

Figure 4.6 Recovery from PV at ramp segment

If *SP1* is selected, when power is restored the profile is disabled and enters static mode, and SP1 is selected for control set point.

If *OFF* is selected, when power is restored the profile is disabled and the controller enters OFF mode. All control outputs as well as alarms and events are turned off.

4-9 Configuring the Profile

When first configuring a profile, you should check that the configuration conforms to your requirements.

The following parameters are common to all profiles:

Global Data (Located in ConF menu)

STAR: set point value at start of profile

END: set point value at end of profile

DLAY: Delay time before profile start

PFR: Power fail recovery

HBT: Holdback wait time

The following parameters are used for a specific profile

Profile Data

PROF: Profile number selected for view

HBBD: Holdback band

STSP: Start set point value

RMPU: Unit for ramp segment

DLLU: Unit for dwell segment

The following parameters apply to each segment in a specific profile:

Segment Data

SGNO: Segment number

SGTY: Segment type

TGSP: Target set point

RTRR: Ramp time or ramp rate

P2EV: PID selection and event output states

HBTY: Holdback type

DLLT: Dwell time

SEG: Target segment number for jump segment

CYCL: Repeat number of cycle

FSP: Final set point for the end segment

4-10 Viewing and Creating a Profile

Refer to section 1-5 for key operation. Press page key to obtain configuration page. After completing the configuration of all the parameters including those parameters which are common to all profiles, you can proceed to the profile page to create a profile. To create a specific profile you need to set the profile number at first, then set HBBD, STSP, RMPU, DLLU and SGNO for this profile.

The next parameter is segment type (SGTY). There are four different segment types, these are:

rRnP – Ramp to a new set point at a set rate or in a set time

dLL – Dwell for a set time

JuñP – Jump to a specified segment in the same profile

End – Make this segment the end of the profile

The parameters that follow SGTY (segment type) depend on the type of segment selected as shown in the table below. The function of each parameters follows the table.

Parameter	Segment type (SGTY) selected			
	0 RAMP	1 DLL	2 JUMP	3 END
TGSP	✓			
RTRR	✓			
P2EV	✓	✓		
HBTY	✓	✓		
DLLT		✓		
SEG			✓	
CYCL			✓	✓
FSP				✓

Table 4.3 Parameters that follow Segment Type

Changing Event Input Function

- Press and release “E” key twice until Prof appears on upper display
- Press and hold “E” for 5 sec, then release. ConF should appear on upper display
- Press and release “Return” key (key on far left) 5 times until EiFn appears on Upper display
- Use up/down arrows to select either desired event input function.
- Press up/down arrows at same time to return to home screen.

Changing profile settings

- Press and release “E” key twice until Prof appears on upper display
- Press and release “Return” (key on far left) until the upper display reads SG0
 - The first few options are global settings of the profile, i.e. starting set point, hold back band, etc. These pertain to all segments in the specific profile.
- When SG0 appears on the upper display, use the up/down keys to select which segment you would like to edit.
- When the desired segment is on the upper display, press and release the “Return” key. to edit that segments parameters.
- Parameter descriptions can be found in the instruction manual on pages 8 through 11.
- When finished editing the profile, press up/down keys at same time to return to home page.

Suppose that you need a controller to control a process where the response of the profile must be the same as the figure shown below.

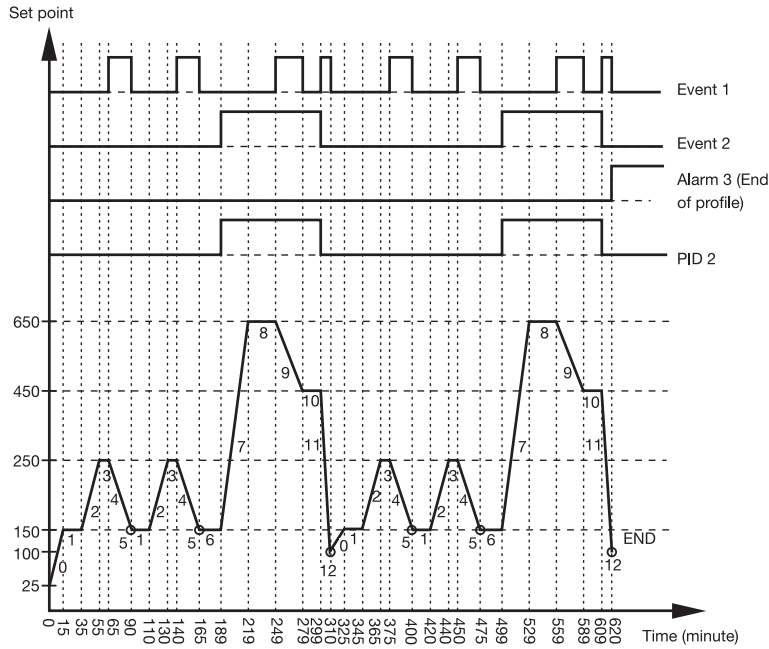

Figure 4.7 Profiling Curve Example

In order to meet the response of the profile curve example, you can make a series of settings of parameters as follows:

Global Data

STAR = STSP
 END = OFF
 DLAY = 0
 PFR = PV
 HBT = 1.00

Profile Data

PROF = 1
 HBBD = 50
 STSP = 25.0
 RMPU = HH.MM
 DLLU = HH.MM

Segment Data

SGNO = 0
 SGTY = RAMP
 TGSP = 150.0
 RTRR = 15
 P2EV = 0000
 HBTY = 1

Segment 0

SGNO = 4
 SGTY = RAMP
 TGSP = 150.0
 RTRR = 25
 P2EV = 0001
 HBTY = 2

Segment 4

SGNO = 8
 SGTY = DLL
 P2EV = 1010
 HBTY = 3
 DLLT = 30

Segment 8

SGNO = 12
 SGTY = END
 CYCL = 2
 FSP = 100.0

Segment 12

SGNO = 1
 SGTY = DLL
 P2EV = 0000
 HBTY = 3
 DLLT = 20

Segment 1

SGNO = 5
 SGTY = JUMP
 SEG = 1
 CYCL = 2

Segment 5

SGNO = 9
 SGTY = RAMP
 TGSP = 450.0
 RTRR = 30
 P2EV = 1011
 HBTY = 2

Segment 9

SGNO = 2
 SGTY = RAMP
 TGSP = 250.0
 RTRR = 20
 P2EV = 0000
 HBTY = 1

Segment 2

SGNO = 6
 SGTY = DLL
 P2EV = 0000
 HBTY = 3
 DLLT = 24

Segment 6

SGNO = 10
 SGTY = DLL
 P2EV = 1010
 HBTY = 3
 DLLT = 20

Segment 10

SGNO = 3
 SGTY = DLL
 P2EV = 0000
 HBTY = 3
 DLLT = 10

Segment 3



SGNO = 7
 SGTY = RAMP
 TGSP = 650.0
 RTRR = 30
 P2EV = 1010
 HBTY = 1

Segment 7

SGNO = 11
 SGTY = RAMP
 TGSP = 100.0
 RTRR = 11
 P2EV = 0001
 HBTY = 2

Segment 11







Controller Settings to Program a Profile

- From the home screen (where process value is displayed on top and set point is displayed on bottom). To get to the home screen, the up/down arrows are pressed and released simultaneously.
- Press and release “E” key twice until Prof appears on upper display”.
- Press and hold the “E” key for 4-6 seconds then release. “ConF” should appear on the upper display. If it does not, repeat the previous step.
- Press and release “enter”  : (key on far left) until “H.b.t.” appears on the upper display. If a holdback timer is to be used, enter the desired holdback time. (see page 33 for details on the function of the hold back band). If a hold back timer is not to be used, ignore this setting.
- Press and release  until “StAr” appears on the upper display. Use the arrow keys to change the lower display to read “StSp”. Alternatively, you can set the profile to begin at whatever the current temperature is (PV), or at whatever the current setpoint is (SP1).
- Press and release  once. “End” will appear on the upper display. Use the arrow keys to change the lower display to read “FSP” to have the option of entering a final setpoint for the profile. Alternatively, you can set the controller to end at the original setpoint value (SP1), or to turn off all outputs except the “end of profile relay” (Off).

Make any other menu changes that are desired, then press the up/down arrows together to return to the home screen.

Changing Profile Settings from the Home Screen

The following instructions are to set a generic ramp and soak profile

- A. Press and release “E” key twice until “Prof” appears on upper display”. On the lower display, select the profile number that you wish to edit using the arrow keys.
1. Press and release “enter”  : (key on far left): Set Hbbd (holdback band) to desired setting. (see page 33 for details on the function of the hold back band)
 2. Press and release “enter”  : Set StSp (starting setpoint) to 75, or at whatever temperature you wish to start profiles at.
 3. Press and release “enter”  : Set RmPu (ramping process units) to HHmm (hours and minutes)
 4. Press and release “enter”  : Set dLLu (dwelling units) to HHmm (hours and minutes)
 5. Press and release “enter”  :
- B. When “SG.no” appears on the upper display, use the up/down keys to select which segment you would like to edit. Profiles begin at segment zero (0).
- C. With “SG.no” on the upper display, press and release the “enter”  key to edit that segment’s parameters.

(Ramping Segment)

SG.no 0: After each setting, press the return key.

1. Set SGty to Ramp
2. Set tGSP 400
3. Set rtrr to 00.10
4. Set (P2EV) to 0000 (see page 40 for details regarding event outputs and PID changes)
5. Set Hbty (holdback type) to “None”
(see page 33 for details on the function of the hold back band)

(Dwell Segment)

SG.no 1: After each setting, press the  key.

1. Set SGty to dLL
2. Set dLLt to 03.00
3. Set the Event Outputs (P2EV) to 0000
4. Set Hbty (holdback type) to “None”

(Ramp Segment)

SG.no 2: After each setting, press the  key.

1. Set SGty to Ramp
2. Set tGSP 700
3. Set rtrr to 00.10
4. Set (P2EV) to 0000
5. Set Hbty (holdback type) to None

(Dwell Segment)

SG.no 3: After each setting, press the  key.

1. Set SGty to dLL
2. Set dLLt to 03.00
3. Set the Event Outputs (P2EV) to 0000
4. Set Hbty (holdback type) to “None”

(Ramp segment)

SG.no 4: After each setting, press the  key.

1. Set SGty to Ramp
2. Set tGSP 1000
3. Set rtrr to 00.10
4. Set (P2EV) to 0000
5. Set Hbty (holdback type) to None

(Dwell Segment)

SG.no 5: After each setting, press the  key.

1. Set SGty to dLL
2. Set dLLt to 04.00
3. Set the Event Outputs (P2EV) to 0000
4. Set Hbty (holdback type) to “None”

(Ramp Segment)

SG.no 6: After each setting, press the  key.

1. Set SGty to Ramp
2. Set tGSP 1300
3. Set rtrr to 00.10
4. Set (P2EV) to 0000
5. Set Hbty (holdback type) to None

(Dwell Segment)

SG.no 7: After each setting, press the  key.

1. Set SGty to dLL
2. Set dLLt to 03.00
3. Set the Event Outputs (P2EV) to 0000
4. Set Hbty (holdback type) to “None”

(End of Profile)

SG.no 8: After each setting, press the return key.

1. Set SGty to End
2. Set FSP to the final setpoint desired (75 or the desired temperature setting when the profile is complete)
3. Set CYCL to how many times you want this profile to Loop. If you only want it to run once, set to 1.

D. When finished editing the profile, press up/down keys at same time to return to home page.

E. **Selecting which profile/segment to run:** From the home screen, press the return Key one time. The lower display will read PX.XX. Using the up or down arrows, select the profile and segment number you wish to start at.

F. **Starting a profile:** From the home screen, press the enter key (“E”) once until the upper display says “mode”. Use the up/down arrows until “run” is displayed on the bottom display. Press and hold the enter key (“E”) until the “run” light illuminates. The profile is now running.

4-11 Event Outputs and PID Selection

The event outputs and PID selection are defined by parameter P2EV in the segment data and parameters OUT2, OUT3 and OUT4. There are up to 3 event outputs that can be configured. The register address # 95 shown in section 1-6 describes how to define event status and select PID values.

There are two sets of PID parameters stored in the memory. If the unit is in RUN or HOLD mode, the PID values are selected by the most significant bit of parameter P2EV (the bit all the way to the left). If the unit is in STAT mode (static or controller mode), the PID values are selected by the event input function EIFN. If the unit is in A-T mode, then PB1, TI1, and TD1 are selected. If the unit is in AT2 mode, then PB2, TI2 and TD2 are selected.

(Ramp segment)

SG.no 2: After each setting, press the key.

1. Set SGty to Ramp
2. Set tGSP 700
3. Set rtrr to 00.10
4. Set (P2EV) to 0000
5. Set Hbty (holdback type) to None

(Dwell Segment)

SG.no 3: After each setting, press the key.

1. Set SGty to dLL
2. Set dLLt to 03.00
3. Set the Event Outputs (P2EV) to 0000
4. Set Hbty (holdback type) to "None"

(Ramp segment)

SG.no 4: After each setting, press the key.

1. Set SGty to Ramp
2. Set tGSP 1000
3. Set rtrr to 00.10
4. Set (P2EV) to 0000
5. Set Hbty (holdback type) to None

(Dwell Segment)

SG.no 5: After each setting, press the key.

1. Set SGty to dLL
2. Set dLLt to 04.00
3. Set the Event Outputs (P2EV) to 0000
4. Set Hbty (holdback type) to "None"

Chapter 5 Applications

A heat treatment oven needs to vary temperature as a function of time. The process requires a rapid increase in temperature as it is heated, as well as a rapid decrease in temperature as it is cooled. In order to achieve a rapid increase of temperature, an additional heater is turned on during the ramp up period. This additional heater is connected to output 4. A fan is turned on to accelerate the cooling rate during the cool down period. This fan is connected to output 2. An alarm is needed to announce to the operator that the process is finished.

Since the conditions are different when an additional heater is turned on and the process has the potential to heat up much faster than with a single heater, the PID control parameters should be different than those of the PID values for using a single heater to maintain the temperature. A TEC-4500 profiling controller is perfectly suited to meet the above requirements. The system diagram is shown below.

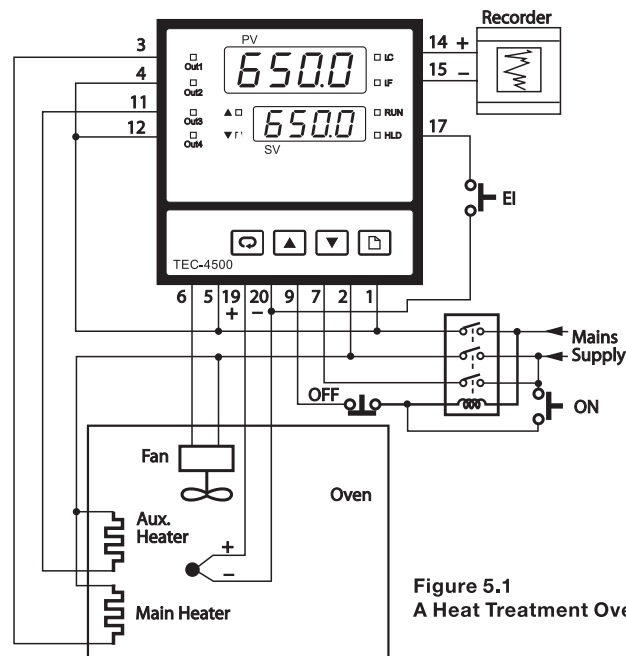

Figure 5.1
A Heat Treatment Oven

Output 1 is used to drive the main heater, output 2 is used to drive the cooling fan, output 3 is used for the end of profile relay, and output 4 is used to drive the auxiliary heater.

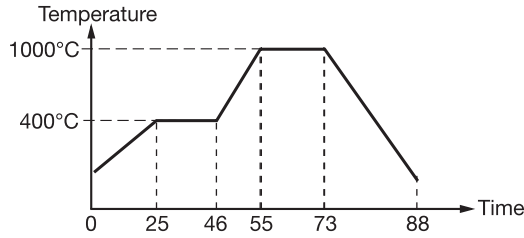

Figure 5.2 Temperature profile of the Heat Treatment Oven

The temperature profile is shown as Figure 2. To achieve this profile, the controller is configured to the following settings:

Global Data (Found in Configuration Menu)

STAR = PV (Profile will start at the current process value regardless of starting setpoint [STSP])
 END = OFF (Controller will turn off at the end of the profile regardless of final setpoint [FSP])
 DLAY = 0
 PFR =CONT
 HBT = 0.05

NOTE: Refer to Page 10 for STAR and END options

Profile Data

PROF = 1
 STSP = 50 (Not Applicable because “STAR” is set to begin the profile at the current process value)
 HBBD = 50
 RMPU = HH.MM
 DLLU = HH.MM

Segment Data

SGNO = 0	SGNO = 1	SGNO = 2	SGNO = 3	SGNO = 4	SGNO = 5
SGTY = RAMP	SGTY = DLL	SGTY = RAMP	SGTY = DLL	SGTY = RAMP	SGTY = END
TGSP = 400.0	P2EV = 0000	TGSP = 1000.0	P2EV = 1100 (See Note 1)	TGSP = 25.0	CYCL = 1
RTRR = 25	HBTY = 3	RTRR = 9	HBTY = 3	RTRR = 15	FSP = 25.0
P2EV = 0000	DLLT = 21	P2EV = 1100	DLLT = 18	P2EV = 0001 (See Note 2)	
HBTY = 1		HBTY = 1		HBTY = 2	

Note 1: Second set of PID values (PID2) enabled
 Output 4 enabled

Note 2: Output 2 enabled

Controller Configuration Data

INPT = K_TC	OUT4 = EVN3
OUT1 = HTPC	OUT5 = REPV
O1FT = 0.0	OP5L = 0.0
UNIT = °C	OP5H = 100.0
DP = 1_DP	REL5 = 0.0
CYC1 = 18.0	REH5 = 1000.0
OUT2 = EVN1	ALF2 = ENDP
OUT3 = ALM2	A2MD = NORM

Auto-tuning is performed at 400°C for PID1 and 1000°C for PID2.

Chapter 6 Specifications

Power

90–250 VAC, 47–63 Hz, 12VA, 5W maximum
11–26VAC/VDC, 12VA, 5W maximum

Input

Resolution: 18 bits

Sampling rate: 5 samples / second

Maximum rating: –2VDC minimum, 12VDC maximum
(1 minute for mA input)

Temperature effect:

±1.5uV/°C for all inputs except mA input
±3.0uV/°C for mA input

Sensor lead resistance effect:

T/C: 0.2uV/ohm
3-wire RTD: 2.6°C/ohm of resistance difference of two leads
2-wire RTD: 2.6°C/ohm of resistance sum of two leads

Burn-out Current: 200 nA

Common mode rejection ratio (CMRR): 120dB

Normal mode rejection ratio (NMRR): 55dB

Sensor break detection:

Sensor open for TC, RTD and mV inputs,
Sensor short for RTD input,
Below 1mA for 4–20mA input,
Below 0.25V for 1–5V input,
unavailable for other inputs.

Sensor break responding time:

Within 4 seconds for TC, RTD, and mV inputs, 0.1 seconds
for 4–20mA and 1–5V inputs.

Sensor Characteristics:

Type	Range	Accuracy @ 25°C	Input Impedance
J	-120°C to 1000°C (-184°F to 1832°F)	±2°C	2.2 MΩ
K	-200°C to 1370°C (-328°F to 2498°F)	±2°C	2.2 MΩ
T	-250°C to 400°C (-418°F to 752°F)	±2°C	2.2 MΩ
E	-100°C to 900°C (-148°F to 1652°F)	±2°C	2.2 MΩ
B	0°C to 1800°C (32°F to 3272°F)	±2°C (200°C to 1800°C)	2.2 MΩ
R	0°C to 1767.8°C (32°F to 3214°F)	±2°C	2.2 MΩ
S	0°C to 1767.8°C (32°F to 3214°F)	±2°C	2.2 MΩ
N	-250°C to 1300°C (-418°F to 2372°F)	±2°C	2.2 MΩ
L	-200°C to 900°C (-328°F to 1652°F)	± 2°C	2.2 MΩ
C	0°C to 2315°C (-32°F to 4199°F)	±2°C	2.2 MΩ
P	0°C to 1395°C (32°F to 2543°F)	± 2°C	2.2 MΩ
PT100 (DIN)	-210°C to 700°C (-346°F to 1292°F)	± 0.4°C	1.3 KΩ
PT100 (JIS)	-200°C to 600°C (-328°F to 1112°F)	± 0.4°C	1.3 KΩ
mV	-8mV to 70mV	± 0.05%	2.2 MΩ
mA	-3mA to 27mA	± 0.05%	70.5 Ω
V	-1.3V to 11.5V	± 0.05%	650 KΩ

Output 1/Output 2

Relay rating: 2A/240VAC, 200,000 life cycles for resistive load

Pulsed voltage: Source voltage 5V, current limiting resistance 66 Ohms.

Linear Output

Resolution: 15 bits

Output regulation: 0.02% for full load change

Output settling time: 0.1 sec. (stable to 99.9%)

Isolation breakdown voltage: 1000VAC

Temperature effect: ±0.01% of SPAN/°C

Triac (SSR) Output

Rating: 1A/240 VAC

Inrush current: 20A for 1 cycle

Min. load current: 50mA rms

Max. off-state leakage: 3mA rms

Max. on-state voltage: 1.5V rms

Insulation resistance: 1000Mohms min. at 500 VDC

Dielectric strength: 2500VAC for 1 minute

Linear Output Characteristics

Type	Zero Tolerance	Span Tolerance	Load Capacity
4-20mA	3.8-4mA	20-21mA	500Ω max.
0-20mA	0 mA	20-21mA	500Ω max.
0 – 5 V	0 V	5 – 5.25 V	10 KΩ min.
1 – 5 V	0.9 – 1 V	5 – 5.25 V	10 KΩ min.
0 – 10 V	0 V	10 – 10.5 V	10 KΩ min.

DC Voltage Supply Characteristics (Installed at Output 2)

Type	Tolerance	Max. Output Current	Ripple Voltage	Isolation Barrier
20 V	± .5 V	25 mA	0.2 Vp-p	500 VAC
12 V	± 0.3 V	40 mA	0.1 Vp-p	500 VAC
5 V	± 0.15 V	80 mA	0.05 Vp-p	500 VAC

Alarm

Alarm relay: Form C

2A/240VAC, 200,000 life cycles for resistive load.

Alarm functions: Dwell timer

Deviation high/low alarm

Deviation band high/low alarm

PV high/low alarm

Alarm modes: Normal, latching, hold, latching/hold.

Dwell timer: 0.1–4553.6 minutes

Data Communication

Interface: RS-232 (1 unit), RS-485 (up to 247 units)

Protocol: Modbus protocol RTU mode

Address: 1–247

Baud rate: 2.4–38.4Kbits/sec

Data bits: 7 or 8 bits

Parity bit: None, even or odd

Communication buffer: 256 bytes

Analog Retransmission

Output Signal: 4-20mA, 0-20mA, 0-5V, 1-5V, 0-10V

Resolution: 15 bits

Accuracy: $\pm 0.05\%$ of span $\pm 0.0025\%$ / °C

Load Resistance:

0-500 Ohms (for current output)

10 K Ohms minimum (for voltage output)

Output Regulation: 0.01% for full load charge

Output Settling Time: 0.1sec (stable to 99.9%)

Isolation Breakdown Voltage: 1000 Vac for 1 min.

Integral Linearity Error: $\pm 0.005\%$ of span

Temperature Effect: $\pm 0.0025\%$ of span/°C

Saturation Low: 0 mA or (0V)

Saturation High: 22.2 mA (or 5.55V, 11.1V/min)

Linear Output Range: 0-22.2 mA (0-20 mA or 4-20 mA)
0-5.55V (0-5V, 1-5V)
0-11.1 V (0-10V)

User Interface

Dual 4-digit LED displays

Keypad: 4 keys

Programming port: For automatic setup, calibration and testing

Communication port: RS-232 and RS-485

Control Mode

Output 1: Reverse (heating) or direct (cooling) action

Output 2: PID cooling control, cooling P band 50~300% of PB, dead band -36.0~36.0% of PB

ON-OFF: 0.1–90.0 (°F) hysteresis control (P band=0)

P or PD: 0–100.0% offset adjustment

PID: Fuzzy logic modified

Proportional band 0.1–900.0°F

Integral time 0–1000 seconds

Derivative time 0–360.0 seconds

Cycle time: 0.1–90.0 seconds

Manual control: Heat (MV1) and cool (MV2)

Auto-tuning: Cold start and warm start

Failure mode: Auto-transfer to manual mode while sensor break or A-D converter damage

Ramping control: 0–900.0°F/minute or
0–900.0°F/hour ramp rate

Digital Filter

Function: First order

Time constant: 0, 0.2, 0.5, 1, 2, 5, 10, 20, 30, 60 seconds programmable

Profile

Number of profiles: 9

Number of Segment per profile:

Profile 1, 2, 3, 4: 16

Profile 5, 6, 7: 32

Profile 8, 9: 64

Environmental and Physical

Operating temperature: -10°C to 50°C

Storage temperature: -40°C to 60°C

Humidity: 0 to 90% RH (non-condensing)

Insulation resistance: 20Mohms min. (at 500VDC)

Dielectric strength: 2000VAC, 50/60 Hz for 1 minute

Vibration resistance: 10–55 Hz, 10 m/s² for 2 hours

Shock resistance: 200m/s² (20g)

Moldings: Flame retardant polycarbonate

Dimensions:

TEC-4500 — 3-3/4 × 3-3/4 × 2-9/16" H × W × D
(96 × 96 × 65 mm)

Depth behind panel: 2" (53 mm)

TEC-9500 — 1-7/8 × 1-7/8 × 4-9/16" H × W × D
(48 × 48 × 116 mm)

Depth behind panel: 4" (105 mm)

Weight: TEC-4500—250 grams

TEC-9500—150 grams

Approval Standards

Safety: UL61010C-1

EN61010-1

(IEC1010-1) **Protective class:**

IP65 for panel with additional option

IP50 for panel without additional option

IP20 for terminals and housing with protective cover.

All indoor use.

EMC: EN61326

Chapter 7 Modbus Communications

This chapter specifies the Modbus Communications protocol when an RS-232 or RS-485 interface module is installed. Only RTU mode is supported. Data is transmitted as eight-bit binary bytes with 1 start bit, 1 stop bit and optional parity bit checking (None, Even or Odd). Baud rate may be set to 2400, 4800, 9600, 14400, 19200, 28800 and 38400.

7-1 Functions Supported

Only function 03, 06, and 16 are available for this series of controllers. The message formats for each function are described as follows:

Function 03: Read Holding Registers

Query: (from Primary)	Response: (from Secondary)
Slave address (1-247)	←
Function code (3)	←
Starting address of register Hi (0)	Byte count
Starting address of register Lo (0-117, 128-143)	Data 1 Hi
No. of words Hi (0)	Data 1 Lo
No. of words Lo (1-118)	Data 2 Hi
CRC16 Hi	Data 2 Lo
CRC16 Lo	•
	•
	•
	•
	•
	CRC16 Hi
	CRC16 Lo

Function 06: Preset Single Register

Query: (from Primary)	Response: (from Secondary)
Slave address (0-247)	←
Function code (6)	←
Register address Hi (0)	←
Register address Lo (0-117, 128-143)	←
Data Hi	←
Data Lo	←
CRC16 Hi	←
CRC16 Lo	←

Function 16: Preset Multiple Registers

Query: (from Primary)	Response: (from Secondary)
Slave address (0-247)	←
Function code (16)	←
Starting address of register Hi (0)	←
Starting address of register Lo (0-117, 128-143)	←
No. of words Hi (0)	←
No. of words Lo (1-118)	←
Byte count (2-136)	CRC16 Hi
Data 1 Hi	CRC16 Lo
Data 1 Lo	
Data 2 Hi	
Data 2 Lo	
•	
•	
•	
•	
•	
CRC16 Hi	
CRC16 Lo	

7-2 Exception Responses

If the controller receives a message which contains a corrupted character (parity check error, framing error etc.), or if the CRC16 check fails, the controller ignores the message. However, if the controller receives a syntactically correct message which contains an illegal value, it will send an exception response consisting of five bytes as follows:

slave address +offset function code + exception code + CRC16 Hi +CRC16 Lo

The offset function code is obtained by adding the function code with 128 (ie. function 3 becomes H'83), and the exception code is equal to the value contained in the following table:

Exemption Code	Name	Cause
1	Bad Function Code	Function code is not supported by the controller
2	Illegal data address	Register address out of range
3	Illegal data value	Data value out of range or attempt to write a read-only or protected data

Table 7.1 Exception Code Table

7-3 Parameter Table

You can refer to section 1-6 for the parameter description. The register address for each parameter is shown in the first column of the table.

The register 133 for EROR is the error code. The error code description is shown in Table A.1. The register 140 for PROG is the program code of the product. The program code is 37.xx for TEC-4500 and 38.xx for TEC-9500 where xx denotes the software version number. For example, PROG = 37.12 means that the controller is TEC-4500 with software version 12.

7-4 Number System

The values stored in registers are based on a 2's complement format.

The relation between the value of a number in the register and its actual value is shown as following table:

Number in Register	Actual Value
65535	-1
65534	-2
50000	-15536
32769	-32767
32768	-32768
32767	32767
10000	10000
3	3
2	2
1	1
0	0

Table 7.2 Number Conversion Table

7-5 Communication Example

Example 1: Read the real time data (register 128~141)

Query

	03	00	0x80	00	0x0E	Hi	Lo
Addr.	Func.	Starting Addr.		No. of words		CRC16	

Example 2: Read segment 2 data of profile 3

Query

	06	00	0x56	00	03	Hi	Lo
Addr.	Func.	Starting Addr.		Data Hi / Lo		CRC16	

Query

	06	00	0x5B	00	02	Hi	Lo
Addr.	Func.	Register Addr.		Data Hi / Lo		CRC16	

Query

	03	00	0x5C	00	09	Hi	Lo
Addr.	Func.	Starting Addr.		No. of words		CRC16	

Example 3 : Perform reset function

Query

	06	00	0x8E	0x68	0x25	Hi	Lo
Addr.	Func.	Register Addr.		Data Hi / Lo		CRC16	

Example 4 : Enter auto-tuning mode

Query

	06	00	0x0B	00	03	Hi	Lo
Addr.	Func.	Register Addr.		Data Hi / Lo		CRC16	

Example 5 : Enter manual mode

Query

	06	00	0x0B	00	05	Hi	Lo
Addr.	Func.	Register Addr.		Data Hi / Lo		CRC16	

Example 6 : Modify the Calibration coefficient

Preset the CMND register with 26668 before attempting to change the calibration coefficient.

Query

	06	00	0x8E	0x68	0x2C	Hi	Lo
Addr.	Func.	Register Addr.		Data Hi / Lo		CRC16	

Example 7 : Start from segment 4 to run profile 3

Query

	06	00	0x0B	00	00	Hi	Lo
Addr.	Func.	Register Addr.		Data Hi / Lo		CRC16	

Query

	06	00	01	01	0x30	Hi	Lo
Addr.	Func.	Register Addr.		Data Hi / Lo		CRC16	

Example 8 : Hold the current profile

Query

	06	00	0x0B	00	01	Hi	Lo
Addr.	Func.	Register Addr.		Data Hi / Lo		CRC16	

Example 9 : Create the profile which is specified in example of Fig. 4.7

Query

	0x10	00	0x50	00	05	0x0A	00	02	00	02
Addr.	Func.	Starting Addr.	No. of words	Bytes	STAR = 2	END = 2				
00	00	00	01	00	0x64	Hi	Lo			
DLAY = 0	PFR = 1	HBT = 1.00	CRC16							

Query

	0x10	00	0x56	00	05	0x0A	00	01		
Addr.	Func.	Starting Addr.	No. of words	Bytes	PROF = 1					
00	0x32	00	0xFA	00	00	00	00	Hi	Lo	
HBBD = 5.0	STSP = 25.0	RMPU = 0	DLLU = 0	CRC16						

Query

	0x10	00	0x5B	00	06	0x0C	00	00	00	00
Addr.	Func.	Starting Addr.	No. of words	Bytes	SGNO = 0	SGTY = 0				
0x05	0xDC	00	0x0F	00	00	00	01	Hi	Lo	
TGSP = 150.0	RTRR = 15	P2EV = 0	HBTY = 1	CRC16						

Query

	0x10	00	0x5B	00	02	04	00	01	00	01	Hi	Lo
Addr.	Func.	Starting Addr.	No. of words	Bytes	SGNO=1	SGTY=1	CRC16					

Query

	0x10	00	0x5F	00	03	06	00	00	00	03	00	0x14	Hi	Lo
Addr.	Func.	Starting Addr.	No. of words	Bytes	P2EV=0	HBTY=3	DLLT=20	CRC16						

Query

	0x10	00	0x5B	00	06	0x0C	00	02	00	00
Addr.	Func.	Starting Addr.	No. of words	Bytes	SGNO = 2	SGTY = 0				
0x09	0xC4	00	0x14	00	00	00	01	Hi	Lo	
TGSP = 250.0	RTRR = 20	P2EV = 0	HBTY = 1	CRC16						

Query

	0x10	00	0x5B	00	02	04	00	03	00	01	Hi	Lo
Addr.	Func.	Starting Addr.	No. of words	Bytes	SGNO=3	SGTY=1	CRC16					

Query

	0x10	00	0x5F	00	03	06	00	00	00	03	00	0x0A	Hi	Lo
Addr.	Func.	Starting Addr.	No. of words	Bytes	P2EV=0	HBTY=3	DLLT=10	CRC16						

Query

	0x10	00	0x5B	00	06	0x0C	00	04	00	00
Addr.	Func.	Starting Addr.	No. of words	Bytes	SGNO = 4	SGTY = 0				
0x05	0xDC	00	0x19	00	01	00	02	Hi	Lo	
TGSP = 150.0	RTRR = 25	P2EV = 1	HBTY = 2	CRC16						

Query

	0x10	00	0x5B	00	02	04	00	05	00	02	Hi	Lo
Addr.	Func.	Starting Addr.	No. of words	Bytes	SGNO=5	SGTY=2	CRC16					

Query

	0x10	00	0x62	00	02	04	00	01	00	02	Hi	Lo
Addr.	Func.	Starting Addr.	No. of words	Bytes	SEG=2	CYCL=2	CRC16					

Query

	0x10	00	0x5B	00	02	04	00	06	00	01	Hi	Lo
Addr.	Func.	Starting Addr.	No. of words	Bytes	SGNO=6	SGTY=1	CRC16					

Query

	0x10	00	0x5F	00	03	06	00	00	00	03	00	0x18	Hi	Lo
Addr.	Func.	Starting Addr.	No. of words	Bytes	P2EV=0	HBTY=3	DLLT=24	CRC16						

Query

	0x10	00	0x5B	00	06	0x0C	00	07	00	00	0x19	0x64
Addr.	Func.	Starting Addr.	No. of words	Bytes	SGNO=7	SGTY=0	TGSP=650.0					
00	0x1E	00	0A	00	01	Hi	Lo					
RTRR=30	P2EV=10	HBTY = 1	CRC16									

Query

	0x10	00	0x5B	00	02	04	00	08	00	01	Hi	Lo
Addr.	Func.	Starting Addr.	No. of words	Bytes	SGNO=8	SGTY=1	CRC16					

Query

	0x10	00	0x5F	00	03	06	00	0x0A	00	03	00	0x1E	Hi	Lo
Addr.	Func.	Starting Addr.	No. of words	Bytes	P2EV=10	HBT = 3	DLL = 30	CRC16						

Query

	0x10	00	0x5B	00	06	0x0C	00	0x09	00	00	0x11	0x94
Addr.	Func.	Starting Addr.	No. of words	Bytes	SGNO=9	SGTY=0	TGSP=450.0					
00	0x1E	00	0x0B	00	02	Hi	Lo					
RTRR=30	P2EV=11	HBTY = 2	CRC16									

Query

	0x10	00	0x5B	00	02	04	00	0x0A	00	01	Hi	Lo
Addr.	Func.	Starting Addr.	No. of words	Bytes	SGNO=10	SGTY=1	CRC16					

Query

	0x10	00	0x5F	00	03	06	00	0x0A	00	03	00	0x14	Hi	Lo
Addr.	Func.	Starting Addr.	No. of words	Bytes	P2EV=10	HBTY=3	DLLT=20	CRC16						

Query

	0x10	00	0x5B	00	06	0x0C	00	0x0B	00	00
Addr.	Func.	Starting Addr.	No. of words	Bytes	SGNO = 11	SGTY = 0				
0x03	0xE8	00	0x0B	00	01	00	02	Hi	Lo	
TGSP = 100.0	RTRR = 11	P2EV = 1	HBTY = 2	CRC16						

Query

	0x10	00	0x5B	00	02	04	00	0x0C	00	03	Hi	Lo
Addr.	Func.	Starting Addr.	No. of words	Bytes	SGNO=12	SGTY=3	CRC16					

Query

	0x10	00	0x63	00	02	04	00	02	0x03	0xE8	Hi	Lo
Addr.	Func.	Starting Addr.	No. of words	Bytes	CYCY=2	FSP=100.0	CRC16					

Table A.1 Error Codes and Corrective Actions

Appendix A-1

Table A-1 Error Codes and Corrective Actions

Error Code	Display Symbol	Error Description	Corrective Action
4	<i>Er 04</i>	Illegal setup values been used: Before COOL is used for OUT2, DIRT (cooling action) has already been used for OUT1, or PID mode is not used for OUT1 (that is PB= 0, and / or TI = 0)	Check and correct setup values of OUT2, PB, TI and OUT1. IF OUT2 is required for cooling control, the control should use PID mode (PB ≠ 0, TI ≠ 0) and OUT1 should use reverse mode (heating action), otherwise, don't use OUT2 for cooling control.
10	<i>Er 10</i>	Communication error: bad function code	Correct the communication software to meet the protocol requirements.
11	<i>Er 11</i>	Communication error: register address out of range	Don't issue an over-range register address to the slave.
14	<i>Er 14</i>	Communication error: attempt to write a read-only data or a protected data	Don't write a read-only data or a protected data to the slave.
15	<i>Er 15</i>	Communication error: write a value which is out of range to a register	Don't write an over-range data to the slave register.
25	<i>HbEr</i>	Holdback time out	Evaluate validity of the PID values
26	<i>AtEr</i>	Fail to perform auto-tuning function	<ol style="list-style-type: none"> 1.The PID values obtained after auto-tuning procedure are out of range. Retry auto-tuning. 2.Don't change set point value during auto-tuning procedure. 3.Use manual tuning instead of auto-tuning. 4. Don't set a zero value for PB. 5. Don't set a zero value for TI. 6. Touch RESET key
27	<i>CAEr</i>	You have selected an input type which was not calibrated	Calibrate the new input type or change input type to the calibrated one.
29	<i>EEPE</i>	EEPROM can't be written correctly	Return to factory for repair.
30	<i>CJEr</i>	Cold junction compensation for thermocouple malfunction	Return to factory for repair.
39	<i>SbEr</i>	Input sensor break, or input current below 1 mA if 4-20 mA is selected, or input voltage below 0.25V if 1 - 5V is selected	Replace input sensor.
40	<i>AdEr</i>	A to D converter or related component(s) malfunction	Return to factory for repair.

RETURNS

No product returns can be accepted without a completed Return Material Authorization (RMA) form.

TECHNICAL SUPPORT

Technical questions and troubleshooting help is available from Tempco. When calling or writing please give as much background information on the application or process as possible.

E-mail: techsupport@tempco.com

Phone: 630-350-2252
800-323-6859

Note: Information in this manual was deemed correct at the time of printing. The policy of Tempco is one of continuous development and product improvement, and we reserve the right to modify specifications and designs without prior notice. Not responsible for typographical errors.

NOTES

Custom Manufacturer Since 1972

ELECTRIC HEATING ELEMENTS • TEMPERATURE CONTROLS • SENSORS • PROCESS HEATING SYSTEMS

HEAT THINGS UP!

With Thousands of Design Variations
We Make Everything You Need.

Band Heaters	Cartridge Heaters
Cast-In Heaters	Coil & Cable Heaters
Radiant Heaters	Strip Heaters
Flexible Heaters	Tubular Heaters
Process Heaters	Instrumentation
Temperature Control	Temperature Sensors



607 N. Central Avenue Wood Dale, IL 60191-1452 USA
P: 630-350-2252 Toll Free: 800-323-6859
F: 630-350-0232 E: info@tempco.com
www.tempco.com